

Active Front End Regenerative Power Supply Unit



Industrial application

AFE200-...-4

AFE200-...-6

■ ■ ■ ■ Instruction Manual

GEFRAN

Information about this manual

Software version

This manual is updated according the software version V 7.x.4.

The identification number of the software version is indicated on the identification plate of the AFE or can be checked with the **Firmware ver.rel** - PAR 490 parameter, menu 2.5

General information

Before using the product, read the safety instruction section carefully. Keep the manual in a safe place and available to engineering and installation personnel during the product functioning period.

Gefran S.p.A has the right to modify products, data and dimensions without notice. The data can only be used for the product description and they can not be understood as legally stated properties.

Thank you for choosing this Gefran product.

We will be glad to receive any possible information which could help us improving this manual.

The e-mail address is the following: techdoc@gefran.com.

All rights reserved

Table of contents

Information about this manual	2
1 - Safety Precautions	6
1.1 Symbols used in the manual	6
1.2 Safety precaution	7
1.3 General warnings	7
1.4 Instruction for compliance with UL Mark (UL requirements), U.S. and Canadian electrical codes	9
2 - Introduction to the product.....	10
2.1 Product type designation	12
2.1.1 Parallel configurations	13
3 - Transport and storage.....	14
3.1 General	14
3.2 Permissible Environmental Conditions	15
4 - Mechanical installation	16
4.1 Inclination and mounting clearance	16
4.2 Fastening positions.....	17
5 - Wiring Procedure.....	22
5.1 Power section	25
5.1.1 Cable Cross Section.....	25
5.1.2 EMC guide line	29
5.1.3 Block diagram power section	30
5.1.4 Power line connection	32
5.1.5 DC output connection.....	33
5.1.6 Connection of fans power supply	35
5.2 Regulation section	36
5.2.1 Removing the terminal cover.....	36
5.2.2 Cable Cross Section.....	36
5.2.3 Regulation section connection	36
5.2.4 Switches, jumpers and LED	38
5.3 Serial interface (XS connector).....	41
5.3.1 AFE / RS 485 Port (not insulated) point-to-point connection.....	41
5.3.2 AFE / RS485 port point-to-point connection (with insulation).....	43
5.3.3 RS 485 multi-drop connection	43
5.4 Typical connection diagrams (with Pre-charge Kit).....	44
5.5 Precharge Kit.....	48
5.5.1 Fuses internal to the pre-charge kit.....	48
5.5.2 Pre-charge kit dimensions and Cable Cross Section	49
5.6 LCL Filters	51
5.6.1 LR3-AFE (Choke) Dimensions, Cable Cross Section and data	54
5.6.2 LC-AFE (Choke + capacitors) Dimensions, Cable Cross Section and data.....	56
5.6.3 L-AFE (Choke) Dimensions, Cable Cross Section and data.....	57
5.6.4 C-AFE (Capacitor) Dimensions and Cable Cross Section	58
6 - Use of the keypad	59
6.1 Description.....	59
6.2 Navigation.....	60
6.2.1 Scanning of the first and second level menus	60
6.2.2 Display of a parameter	60
6.2.3 Scanning of the parameters	61

6.2.4 List of the last parameters modified	61
6.2.5 "Goto parameter" function	61
6.3 Parameter modification.....	62
6.4 How to save parameters.....	63
6.5 Configuration of the display.....	64
6.5.1 Language selection	64
6.5.2 Selection of Easy / Export mode	64
6.5.3 Startup display.....	64
6.5.4 Back-lighting of the display.....	64
6.6 Alarms.....	65
6.6.1 Alarm reset	65
6.7 Messages	65
6.8 Saving and recovery of new parameter settings	66
6.8.1 Selection of the keypad memory	66
6.8.2 Saving of parameters on the keypad.....	66
6.8.3 Load parameters from keypad	67
6.8.4 Transfer of parameters between AFE200.....	67

7 - Commissioning via keypad 68

7.1 Startup Wizard.....	71
7.2 Programming	74
7.2.1 Menu display modes	74
7.2.2 Programming of "function block" analog and digital input signals	74
7.2.3 Variable interconnections mode	74

8 - Description of parameters and functions (Expert list).... 76

Legend	76
8.1 Parameters on selection lists, but not displayed on keypad.....	150
8.2 Selection Lists	155

9 - Troubleshooting..... 160

9.1 Alarms.....	160
9.1.1 "ExtIO fault" Alarm	163
9.1.2 "Fastlink fault" Alarm.....	164
9.2 Messages	165

10 - Specification 168

10.1 Environmental Conditions.....	168
10.2 Standards	168
10.3 Accuracy	168
10.3.1 Current control.....	168
10.3.2 Voltage control.....	168
10.3.3 Current rating	168
10.4 Overload	169
10.5 DC circuit.....	169
10.6 Electrical data	170
10.7 Voltage level of AFE200 for safe operations	172
10.8 Cooling	173
10.9 Weight and dimensions	174

11 - Options 181

11.1 Optional external fuses (mandatory).....	181
11.1.1 Fuses for connection mains side (F1)	181
11.1.2 Fuses for connection DC side	182
11.2 EMC filter	184
11.3 Installation of optional cards	185
11.4.1 Shielding of optional card connections	187

Appendix 1 - Design	188
A1.1 Single-motor calculation based on motor output power	188
A1.2 Calculation for multi-motor system.....	189
Appendix 2 - Parallel connection (400 ... 1650kW sizes)....	192
A 2.1 Introduction.....	192
A 2.2 Compatibility of IGBT modules.....	194
A 2.3 MS-SL interface cable wiring sizes 400...710 kW	195
A 2.4 MS-SL interface cable wiring sizes 900 kW...1 MW	196
A 2.5 MS-SL interface cable wiring size 1.35 MW.....	197
A 2.6 MS-SL interface cable wiring size 1.65 MW.....	198
A 2.7 Jumpers and Switches	199
A 2.8 LEDs.....	199
Appendix 3 - Block Diagrams	202
System Diagrams Index	202
Drive overview	202
Reference	202
Commands	203
Digital inputs	204
Digital outputs.....	205
Analog inputs.....	206
Analog outputs.....	208
Current Control	209
Active Curr Config	210
Functions	211

1 - Safety Precautions

1.1 Symbols used in the manual



Indicates a procedure, condition, or statement that, if not strictly observed, could result in personal injury or death.

Indique le mode d'utilisation, la procédure et la condition d'exploitation. Si ces consignes ne sont pas strictement respectées, il y a des risques de blessures corporelles ou de mort.



Indicates a procedure, condition, or statement that, if not strictly observed, could result in damage to or destruction of equipment.

Indique le mode d'utilisation, la procédure et la condition d'exploitation. Si ces consignes ne sont pas strictement respectées, il y a des risques de détérioration ou de destruction des appareils.



Indicates that the presence of electrostatic discharge could damage the appliance. When handling the boards, always wear a grounded bracelet.

Indique que la présence de décharges électrostatiques est susceptible d'endommager l'appareil. Toujours porter un bracelet de mise à la terre lors de la manipulation des cartes.



Indicates a procedure, condition, or statement that should be strictly followed in order to optimize these applications.

Indique le mode d'utilisation, la procédure et la condition d'exploitation. Ces consignes doivent être rigoureusement respectées pour optimiser ces applications.

Note !

Indicates an essential or important procedure, condition, or statement.

Indique un mode d'utilisation, de procédure et de condition d'exploitation essentiels ou importants

Qualified personnel

For the purpose of this Instruction Manual, a "Qualified person" is someone who is skilled to the installation, mounting, start-up and operation of the equipment and the hazards involved. This operator must have the following qualifications:

- trained in rendering first aid.
- trained in the proper care and use of protective equipment in accordance with established safety procedures.
- trained and authorized to energize, de-energize, clear, ground and tag circuits and equipment in accordance with established safety procedures.

Personne qualifiée

Aux fins de ce manuel d'instructions, le terme « personne qualifiée » désigne toute personne compétente en matière d'installation, de montage, de mise en service et de fonctionnement de l'appareil et au fait des dangers qui s'y rattachent. L'opérateur en question doit posséder les qualifications suivantes :

- formation lui permettant de dispenser les premiers soins

- formation liée à l'entretien et à l'utilisation des équipements de protection selon les consignes de sécurité en vigueur
- formation et habilitation aux manoeuvres suivantes : branchement, débranchement, vérification des isolations, mise à la terre et étiquetage des circuits et des appareils selon les consignes de sécurité en vigueur

Use for intended purpose only

The power drive system (electrical drive + application plant) may be used only for the application stated in the manual and only together with devices and components recommended and authorized by Gefran.

Utiliser uniquement dans les conditions prévues

Le système d'actionnement électrique (drive électrique + installation) ne peut être utilisé que dans les conditions d'exploitation et les lieux prévus dans le manuel et uniquement avec les dispositifs et les composants recommandés et autorisés par Gefran.

1.2 Safety precaution

The following instructions are provided for your safety and as a means of preventing damage to the product or components in the machines connected. This section lists instructions, which apply generally when handling electrical drives. Specific instructions that apply to particular actions are listed at the beginning of each chapters.

Les instructions suivantes sont fournies pour la sécurité de l'utilisateur tout comme pour éviter l'endommagement du produit ou des composants à l'intérieur des machines raccordées. Ce paragraphe dresse la liste des instructions généralement applicables lors de la manipulation des drives électriques.

Les instructions spécifiques ayant trait à des actions particulières sont répertoriées au début de chaque chapitre.

Read the information carefully, since it is provided for your personal safety and will also help prolong the service life of your electrical drive and the plant you connect to it.

Lire attentivement les informations en matière de sécurité personnelle et visant par ailleurs à prolonger la durée de vie utile du drive tout comme de l'installation à laquelle il est relié.

1.3 General warnings

.....



This equipment contains dangerous voltages and controls potentially dangerous rotating mechanical parts. Non-compliance with Warnings or failure to follow the instructions contained in this manual can result in loss of life, severe personal injury or serious damage to property.

Cet appareil utilise des tensions dangereuses et contrôle des organes mécaniques en mouvement potentiellement dangereux. L'absence de mise en pratique des consignes ou le non-respect des instructions contenues dans ce manuel peuvent provoquer le décès, des lésions corporelles graves ou de sérieux dégâts aux équipements.

This equipment contains dangerous voltages and controls potentially dangerous rotating mechanical parts. Non-compliance with Warnings or failure to follow the instructions contained in this manual can result in loss of life, severe personal injury or serious damage to property.

Les drives occasionnent des mouvements mécaniques. L'utilisateur est tenu de s'assurer que de tels mouvements mécaniques ne débouchent pas sur des conditions d'insécurité. Les butées de sécurité et les seuils d'exploitation prévus par le fabricant ne doivent être ni contournés ni modifiés.

Only suitable qualified personnel should work on this equipment, and only after becoming familiar with all safety notices, installation, operation and maintenance procedures contained in this manual. The successful and safe operation of this equipment is dependent upon its proper handling, installation, operation and maintenance.

Seul un personnel dûment formé peut intervenir sur cet appareil et uniquement après avoir assimilé l'ensemble des informations concernant la sécurité, les procédures d'installation, le fonctionnement et l'entretien contenues dans ce manuel. La sécurité et l'efficacité du fonctionnement de cet appareil dépendent du bon accomplissement des opérations de manutention, d'installation, de fonctionnement et d'entretien.

In the case of faults, the drive, even if disabled, may cause accidental movements if it has not been disconnected from the mains supply.

En cas de panne et même désactivé, le drive peut provoquer des mouvements fortuits s'il n'a pas été débranché de l'alimentation secteur.

Electrical Shock

The DC link capacitors remain charged at a hazardous voltage even after cutting off the power supply.

Never open the device or covers while the AC Input power supply is switched on.

Minimum time to wait before working on the terminals or inside the device is listed in [section 10.6](#).

Risque de décharge électrique

Les condensateurs de la liaison à courant continu restent chargés à une tension dangereuse même après que la tension d'alimentation a été coupée.

Ne jamais ouvrir l'appareil lorsqu'il est sous tension. Le temps minimum d'attente avant de pouvoir travailler sur les bornes ou bien à l'intérieur de l'appareil est indiqué dans la [section 10.6](#).

Electrical Shock and Burn Hazard:

When using instruments such as oscilloscopes to work on live equipment, the oscilloscope's chassis should be grounded and a differential probe input should be used. Care should be used in the selection of probes and leads and in the adjustment of the oscilloscope so that accurate readings may be made. See instrument manufacturer's instruction book for proper operation and adjustments to the instrument.

Décharge Électrique et Risque de Brûlure : Lors de l'utilisation d'instruments (par exemple oscilloscope) sur des systèmes en marche, le châssis de l'oscilloscope doit être relié à la terre et une sonde différentiel devrait être utilisé en entrée. Les sondes et conducteurs doivent être choisis avec soin pour effectuer les meilleures mesures à l'aide d'un oscilloscope. Voir le manuel d'instruction pour une utilisation correcte des instruments.

Fire and Explosion Hazard:

Fires or explosions might result from mounting Drives in hazardous areas such as locations where flammable or combustible vapors or dusts are present. Drives should be installed away from hazardous areas, even if used with motors suitable for use in these locations.

Risque d'incendies et d'explosions: L'utilisation des drives dans des zones à risques (présence de vapeurs ou de poussières inflammables), peut provoquer des incendies ou des explosions. Les drives doivent être installés loin des zones dangereuses, et équipés de moteurs appropriés.

.....

1.4 Instruction for compliance with UL Mark (UL requirements), U.S. and Canadian electrical codes

Short circuit ratings

AFE200 must be connected to a grid capable of supplying a symmetrical short-circuit power of less than or equal to “xxxx A rms.

The values of the “xxxx” A rms short-circuit current, in accordance with UL requirements (UL 508 c), for each power rating (AFE output in the manual) are shown in the table below.

Short current rating	
AFE output (kW)	SCCR (A) up to 600Vac
1,1...37,3	5000
39...149	10000
150...398	18000
299...447	30000
448-671	42000
672-1193	85000
≥ 1194	100000 ... 200000

Note!

Drive will be protected by semiconductor Fuse type as specified in the instruction manual.

Branch circuit protection

In order to protect AFE against over-current use fuses specified in [par. 11.1](#).

Environmental condition

The AFE has to be considered “Open type equipment”. Max surrounding air temperature equal to 40°C. Pollution degree 2.

Wiring of the input and output power terminals

Use UL listed cables rated at 75°C and round crimping terminals. Crimp terminals with tool recommended by terminal manufacturer.

Field wiring terminals shall be used with the tightening torque specified in [par.](#)

5.1.1.

Over-voltage control

In compliance with CSA-requirements Overvoltage at mains terminal is achieved installing an overvoltage protection device as for :

Type OVR 1N 15 320 from ABB or similar.

Minimum time required for safe DC-link voltage

Before removing AFE cover in order to access internal parts, after mains disconnection wait for time as follow :

Drive size	Safe time (sec)
size 3...5	300
size 6...7 and Parallels	300

2 - Introduction to the product

AFE200 is the series of AC/DC **Active Front End (AFE)** regenerative, DC Bus power supply units

With a powerful 32-bit technology platform and reliable IGBT power stage the **AFE200** offers significant advantages for single or multi-inverter automation systems powered by a common DC bus.

AFE200 is intended to power the **ADV200...-DC** fed family of AC inverters, either single module or multi-modules with their DC buses tied in parallel.

It may also be used to supply ADV200-...-IT series intended to be powered from a DC input.



.....
About use with standard products (i.e. ADV200...-4 or -6) or other brand products.

AC fed inverters may utilize input filter capacitors that exist from the input diode bridge to ground. These capacitors are subject to failure if the product is powered via the DC bus input.

In this scenario, the input filter capacitors should be removed before powering up the unit from an AFE...

For GEFTRAN legacy or AC fed units, please consult the factory.

For Other Brand products, consult the manufacturer of that product.

.....

Note!

.....
In order to work properly, an external LCL type line input filter and precharge kit is needed.

LCL filters must be chosen based on the overload required for the AFE: Heavy Duty or Low Duty.

.....

Connection with Precharge Kit and LCL Filter

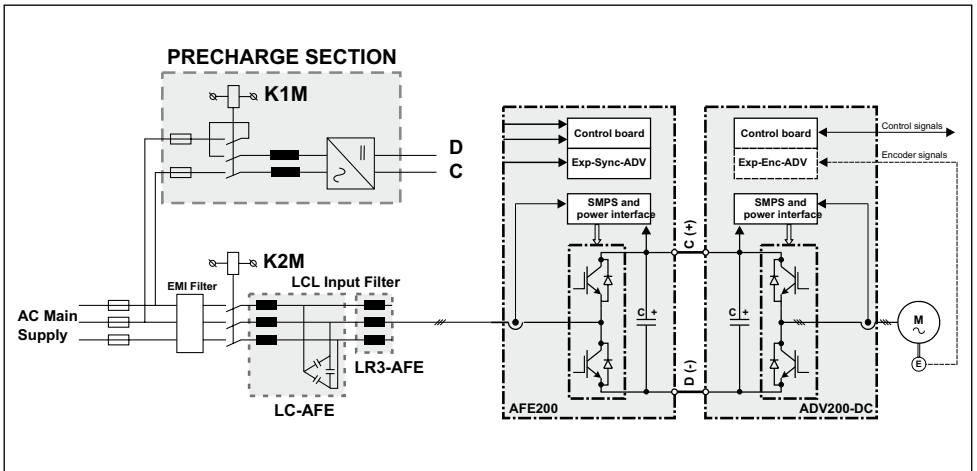

Reduced operating costs

The AFE200 achieves **considerable savings in terms of power consumption and the relative costs**. The kinetic energy of the inertia of the loads transformed into electric energy by the **AFE200 is sent back to the mains supply during**

braking. In conventional resistor braking systems this power is dissipated in the form of heat. The excess energy can be used to supply other equipment.

Production of Clean Power

The regeneration technology of the AFE200 uses advanced control algorithms to provide clean power. **A significant reduction in harmonic distortion** (less than 3% considering an AC main supply with THD voltage lower than 2%) and the input current in phase with the input voltage enable **unitary power factor operation**, for additional **energy saving and system efficiency**.

Enhanced control dynamics

Used in single or multi-inverter solutions powered by a common DC bus the AFE200 also guarantees **high-level control dynamics** in AFE and energy regeneration conditions, which would be impossible with electric braking solutions. Control and monitoring performed on the DC-link also prevent the risk of undesirable stoppages during power transients and make the **AFE200 a reliable solution** for use in networks with high voltage fluctuation levels.

Typical applications

The **AFE200** is ideal for applications that require management of high-inertia loads or with high operating dynamics, such as: test benches, industrial lifting applications, centrifuges, mixers, ventilation systems, renewable energy systems, rolling systems, high-power servo systems, etc.

The economic benefits of using the AFE200 in applications such as these are not of secondary importance.

2.1 Product type designation

The main technical characteristic of the AFE200 are showed in the product code and in the nameplate.

AFE200 3 200 -KX X -4 -XX YY

Parallel version only:
 XX : MS = MASTER
 SL = SLAVE with MS/SL cable 1m length
 SL2 = SLAVE with MS/SL cable 2m length

YY : 04 = 400.0 kW
 05 = 500.0 kW
 06 = 630.0 kW
 07 = 710.0 kW
 09 = 900.0 kW
 10 = 1 MW
 14 = 1.35 MW
 17 = 1.65 MW

Rated voltage (factory setting):

4 = 400 Vac, 50 Hz
 6 = 500...690 Vac

Software: X = standard

Braking unit: B = included
 X = not included

Keypad: K = included
 X = non included

Power, in kW:
 200 = 22.0 kW
 450 = 45.0 kW
 900 = 90.0 kW
 1100 = 110.0 kW
 1320 = 132.0 kW
 1600 = 160.0 kW

2000 = 200.0 kW
 2500 = 250.0 kW
 3150 = 315.0 kW
 3550 = 355.0 kW

Mechanical sizes:

3 = size 3
 4 = size 4
 5 = size 5

6 = size 6
 7 = size 7

Active Front End Regenerative Power Supply Unit

Identification Nameplate

Serial number	Gefran S.p.A via G.Carducci, 24 I-21040-Gerenzano, VA	
Model	Type: AFE200-3220-KXX-4	S/N: 09012345
Input (mains supply)	Inp: 400Vac -15% + 500 Vac +5% 50/60 Hz 3ph 40A@400Vac 36A@480Vac	
Output (Output voltage, power, current, CT and VT overloads)	Out: 650Vdc-780Vdc 28kW 43A @650Vdc 39A @780Vdc Ovid.150%-60s 42kW 64A @650Vdc 57A @780Vdc Ovid.110%-60s	
Approvals		

Firmware & cards revision level nameplate

Firmware Release	HW release					S/N	09012345	Prod. CONF
	D	F	P	R	S	BU	SW . CFG	
Firmware revision	0.8.0	A	-G	-I			10.10.10	A1
Cards revision								
			Power Regulation	Safety	Braking unit		Software revision	Product configuration

The choice of AFE200 depends on the power rating of the inverters connected to the DC-link.

The rated output current of the AFE200 must be higher or equal to the sum of the power ratings of the AFE200 connected to the DC-link. For further information please see Appendix 1.

(*) The power rating in kW shown on the product data plate refers to that of the equivalent ADV200-DC.

2.1.1 Parallel configurations

A parallel connection of several units basically consists of one MASTER unit and one or more SLAVE units.

When placing your order **please give the code number of the master and slave and number of these:**

Power	code	Description (Designation)
400kW	S9AF21M	AFE200-72000-KXX-4-MS 04
	S9AF21S	AFE200-72000-KXX-4-SL
500kW	S9AF22M	AFE200-72500-KXX-4-MS 05
	S9AF22S	AFE200-72500-KXX-4-SL
630kW	S9AF23M	AFE200-73150-KXX-4-MS 06
	S9AF23S	AFE200-73150-KXX-4-SL
710kW	S9AF24M	AFE200-73550-KXX-4-MS 07
	S9AF24S	AFE200-73550-KXX-4-SL
900kW	S9AF231	AFE200-73150-KXX-4-MS 09
	S9AF23S	AFE200-73150-KXX-4-SL
	S9AF23S	AFE200-73150-KXX-4-SL
1MW	S9AF241	AFE200-73550-KXX-4-MS 10
	S9AF24S	AFE200-73550-KXX-4-SL
	S9AF24S	AFE200-73550-KXX-4-SL

Power	code	Description (Designation)
400kW	S9AF51M	AFE200-72000-KXX-6-MS 04
	S9AF51S	AFE200-72000-KXX-6-SL
500kW	S9AF52M	AFE200-72500-KXX-6-MS 05
	S9AF52S	AFE200-72500-KXX-6-SL
630kW	S9AF53M	AFE200-73150-KXX-6-MS 06
	S9AF53S	AFE200-73150-KXX-6-SL
710kW	S9AF54M	AFE200-73550-KXX-6-MS 07
	S9AF54S	AFE200-73550-KXX-6-SL
900kW	S9AF53M1	AFE200-73150-KXX-6-MS 09
	S9AF53S	AFE200-73150-KXX-6-SL
	S9AF53S	AFE200-73150-KXX-6-SL
1MW	S9AF54M1	AFE200-73550-KXX-6-MS 10
	S9AF54S	AFE200-73550-KXX-6-SL
	S9AF54S	AFE200-73550-KXX-6-SL
1.35MW	S9AF54M4	AFE200-73550-KXX-6-MS 14
	S9AF54S	AFE200-73550-KXX-6-SL
	S9AF54S2	AFE200-73550-KXX-6-SL2
1.65MW	S9AF54M5	AFE200-73550-KXX-6-MS 17
	S9AF54S	AFE200-73550-KXX-6-SL
	S9AF54S	AFE200-73550-KXX-6-SL
	S9AF54S2	AFE200-73550-KXX-6-SL2

3 - Transport and storage



Caution

Correct transport, storage, erection and mounting, as well as careful operation and maintenance are essential for proper and safe operation of the equipment. Protect the AFE200 against physical shocks and vibration during transport and storage. Also be sure to protect it against water (rainfall) and excessive temperatures.

Le bon accomplissement des opérations de transport, de stockage, d'installation et de montage, ainsi que l'exploitation et l'entretien minutieux, sont essentiels pour garantir à l'appareil un fonctionnement adéquat et sûr.

If the AFE have been stored for longer than two years, the operation of the DC link capacitors may be impaired and must be "reformed". Before commissioning devices that have been stored for long periods, connect them to a power supply for two hours with no load connected in order to regenerate the capacitors, (the input voltage has to be applied without enabling the AFE).

En cas de stockage des AFE pendant plus de deux ans, il est conseillé de contrôler l'état des condensateurs CC avant d'en effectuer le branchement. Avant la mise en service des appareils, ayant été stockés pendant long temps, il faut alimenter variateurs à vide pendant deux heures, pour régénérer les condensateurs : appliquer une tension d'alimentation sans actionner le AFE.

3.1 General

A high degree of care is taken in packing the AFE200 product and preparing them for delivery. They should only be transported with suitable transport equipment (see weight data). Observe the instructions printed on the packaging. This also applies when the device is unpacked and installed in the control cabinet.

Upon delivery, check the following:

- the packaging for any external damage
- whether the delivery note matches your order.

Open the packaging with suitable tools. Check whether:

- any parts were damaged during transport
- the device type corresponds to your order

In the event of any damage or of an incomplete or incorrect delivery please notify the responsible sales offices immediately. The devices should only be stored in dry rooms within the specified temperature ranges .

Note!

A certain degree of moisture condensation is permissible if this arises from changes in temperature. This does not, however, apply when the devices are in operation. Always ensure that there is no moisture condensation in devices that are connected to the power supply!

3.2 Permissible Environmental Conditions

Temperature

storage _____	-25...+55°C (-13...+131°F), class 1K4 per EN50178
	-20...+55°C (-4...+131°F), for devices with keypad
transport _____	-25...+70°C (-13...+158°F), class 2K3 per EN50178
	-20...+60°C (-4...+140°F), for devices with keypad

Air humidity

storage _____	5% to 95 %, 1 g/m ³ to 29 g/m ³ (class 1K3 as per EN50178)
transport _____	95 % (3), 60 g/m ³ (4)

A light condensation of moisture may occur for a short time occasionally if the device is not in operation (class 2K3 as per EN50178)

Air pressure:

storage _____	[kPa] 86 to 106 (class 1K4 as per EN50178)
transport _____	[kPa] 70 to 106 (class 2K3 as per EN50178)

- (3) Greatest relative air humidity occurs with the temperature @ 40°C (104°F) or if the temperature of the device is brought suddenly from -25...+30°C (-13°...+86°F).
- (4) Greatest absolute air humidity if the device is brought suddenly from 70...15°C (158°...59°F).

4 - Mechanical installation

The AFE must be mounted on a wall that is constructed of heat resistant material. While the AFE is operating, the temperature of the AFE's cooling fins can rise to a temperature of 158° F (70°C).

Le AFE doit être monté sur un mur construit avec des matériaux résistants à la chaleur. Pendant le fonctionnement du AFE, la température des ailettes du dissipateur thermique peut arriver à 70°C (158° F).

Because the ambient temperature greatly affects AFE life and reliability, do not install the AFE in any location that exceeds the allowable temperature.

Étant donné que la température ambiante influe sur la vie et la fiabilité du AFE, on ne devrait pas installer le AFE dans des places où la température permise est dépassée.

Be sure to remove the desiccant dryer packet(s) when unpacking the AFE. (If not removed these packets may become lodged in the fan or air passages and cause the AFE to overheat).

Lors du déballage du AFE, retirer le sachet déshydraté. (Si celui-ci n'est pas retiré, il empêche la ventilation et provoque une surchauffe du AFE).

Protect the device from impermissible environmental conditions (temperature, humidity, shock etc.).

Protéger l'appareil contre des effets extérieurs non permis (température, humidité, chocs etc.).

4.1 Inclination and mounting clearance

The AFE200 must be mounted in such a way that the free flow of air is ensured see [paragraph 10.7](#) Cooling.

Maximum angle of inclination _____ 30° (referred to vertical position)
 Minimum top and bottom distance _____ 150 mm (≥ AFE200-71600 = 400mm)
 Minimum free space to the front _____ 25 mm
 Minimum distance between drives _____ none
 Minimum distance to the side with the cabinet 10 mm

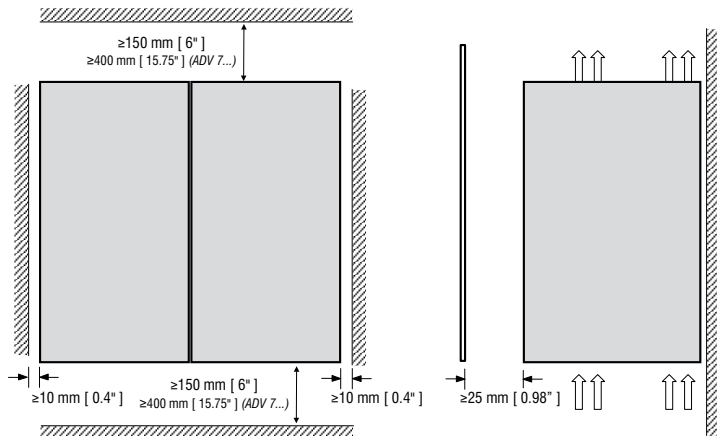

4.2 Fastening positions

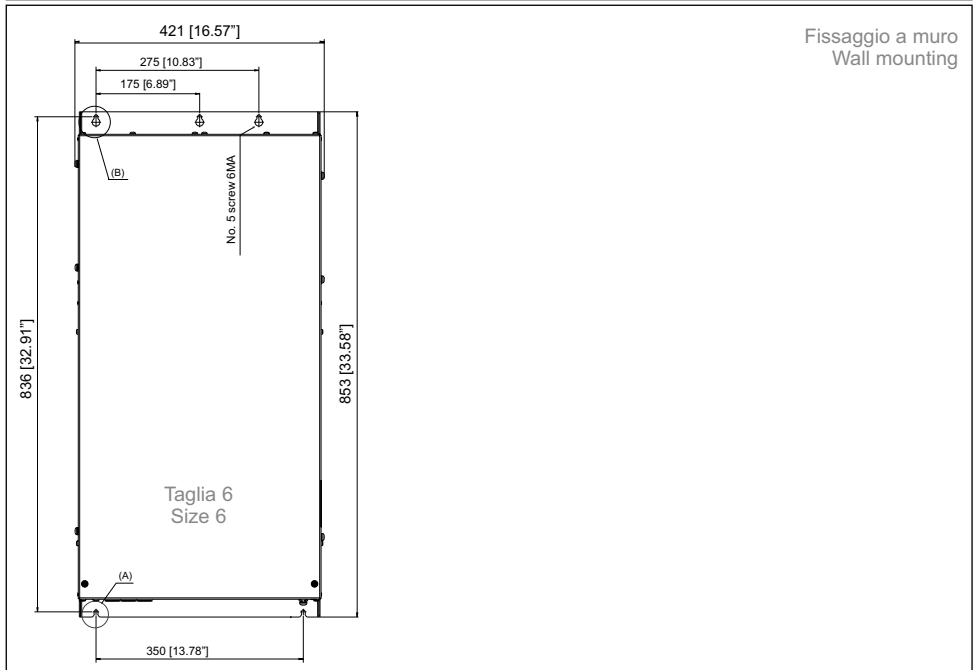
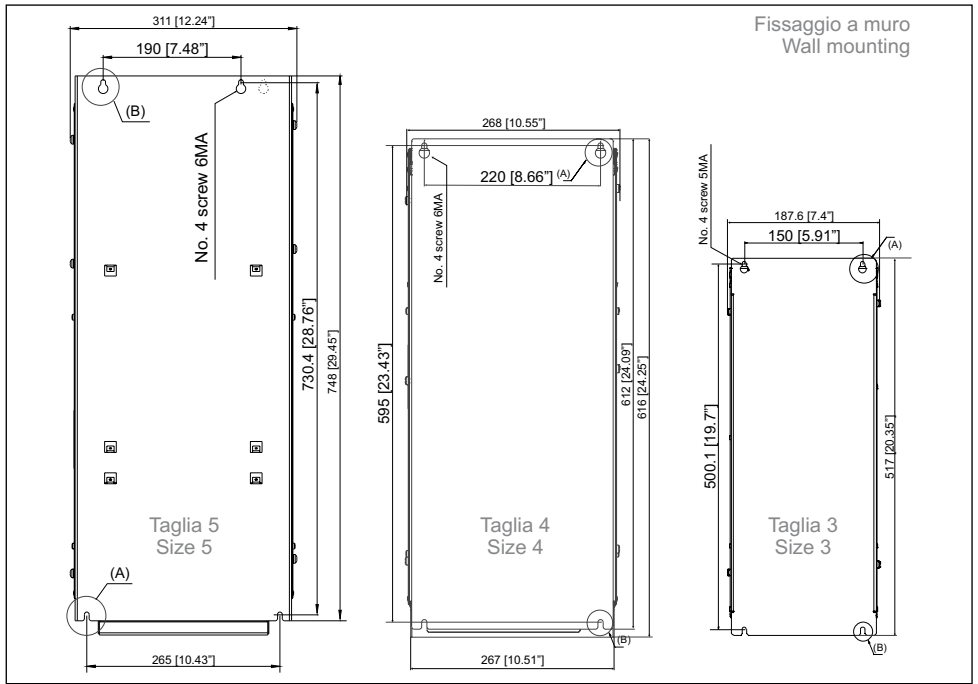

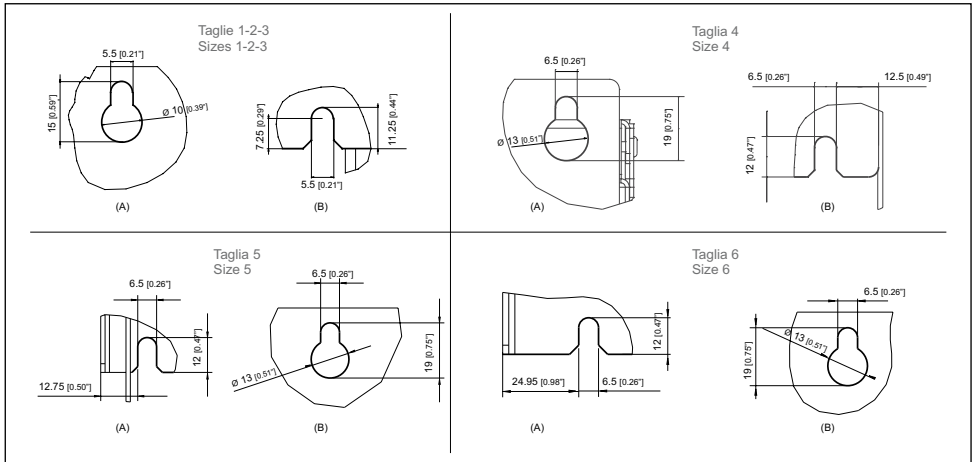
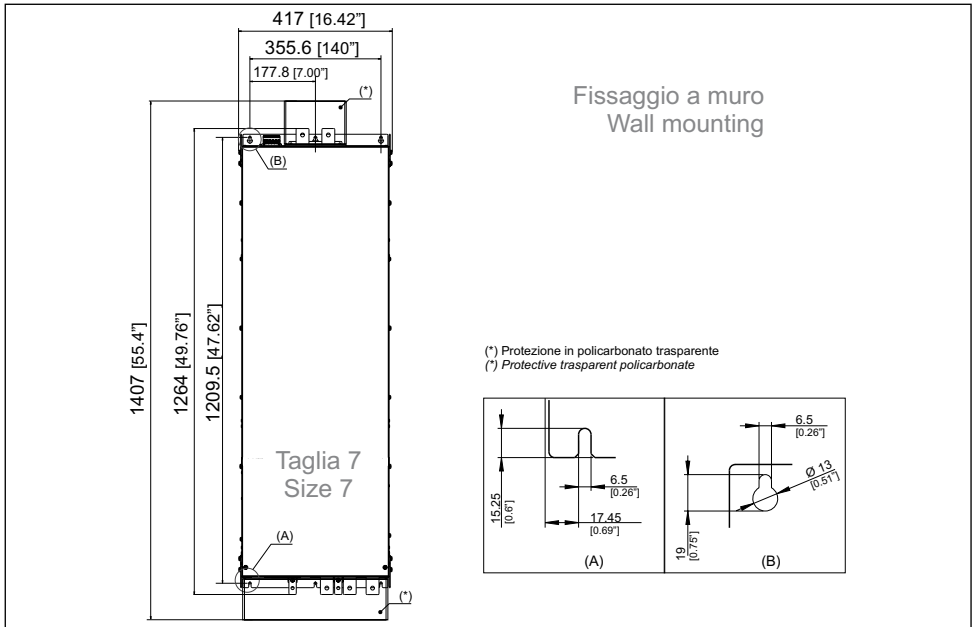

		Recommended screws for fastening
Size 3 (AFE 3...)		4 x M5 x 12 mm screws + Grover (spring-lock) washer + Flat washer
Size 4 (AFE 4...)	Size 5 (AFE 5...)	4 x M6 x 16 mm screws + Grover (spring-lock) washer + Flat washer
Size 6 (AFE 6...)		5 x M6 x 16 mm screws + Grover (spring-lock) washer + Flat washer
Size 7 (AFE 7...)		6 x M6 x 16 mm screws + Grover (spring-lock) washer + Flat washer

Note!

Other dimensions see chapter 10.8 Weight and dimensions.

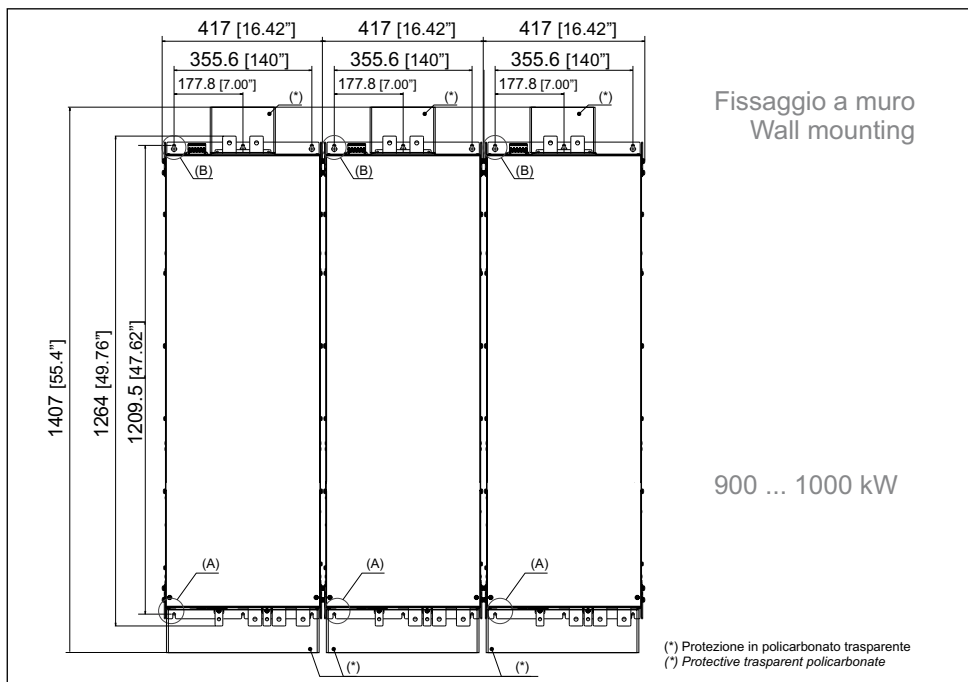
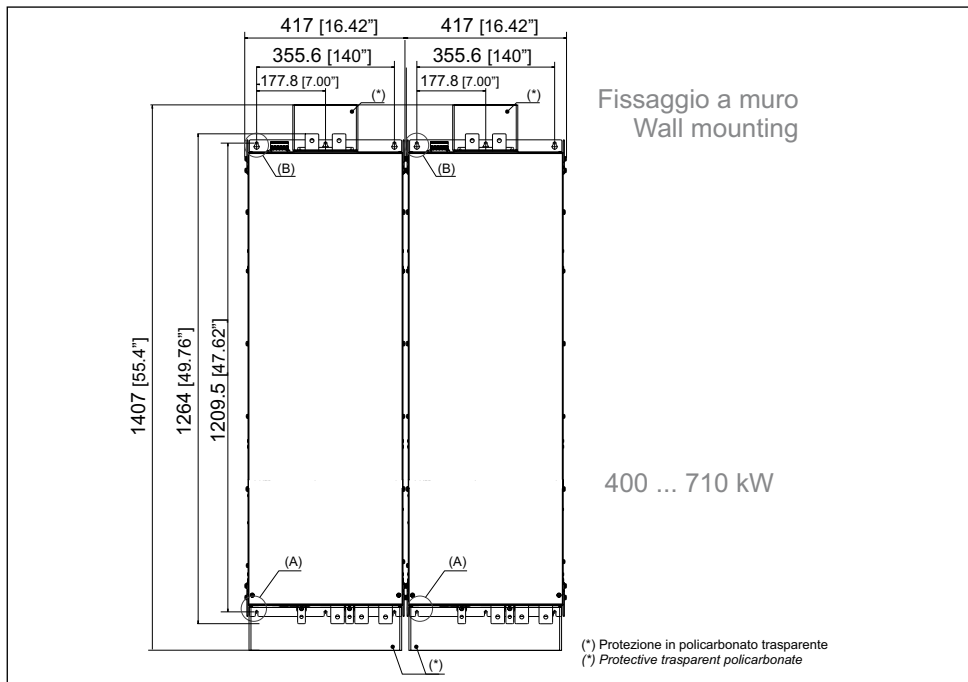

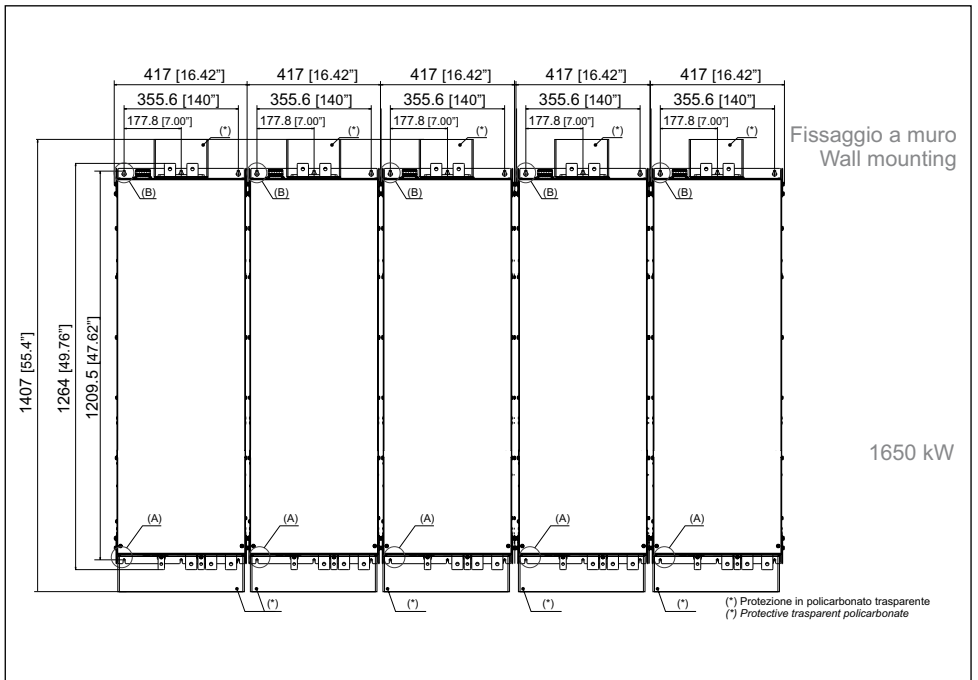
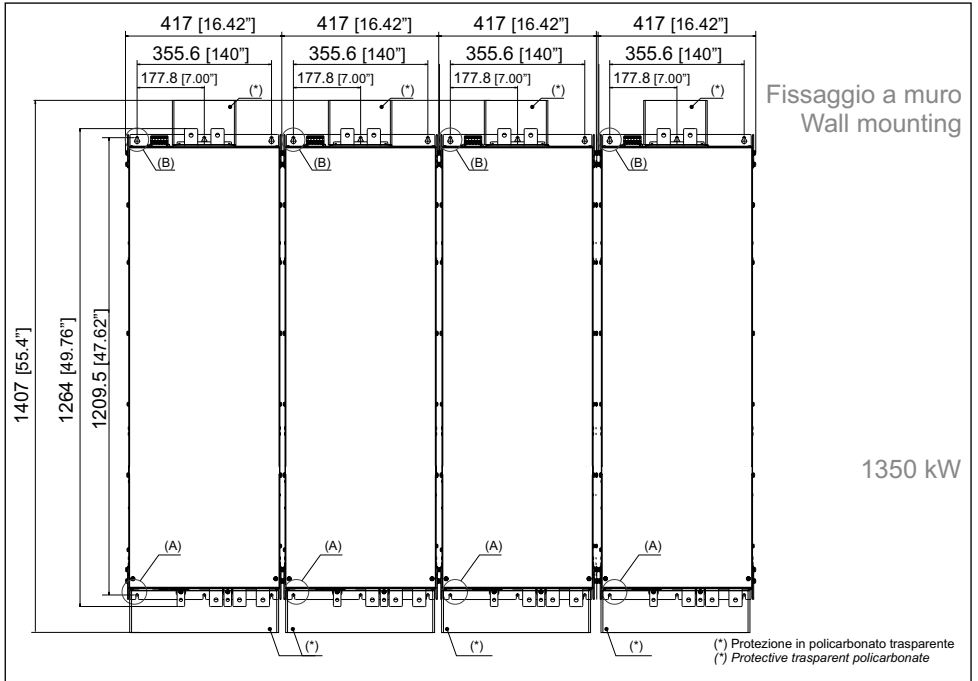

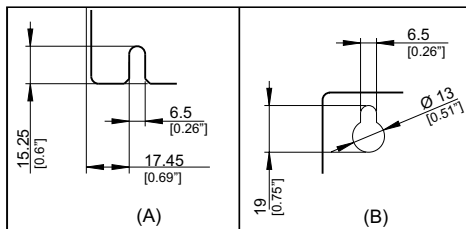

		Recommended screws for fastening
400kW	AFE200-72000-KXX-./.-MS 04 AFE200-72000-KXX-./.-SL	12 x M6 x 16 mm screws + Grover (spring-lock) washer + Flat washer
500kW	AFE200-72500-KXX-./.-MS 05 AFE200-72500-KXX-./.-SL	
630kW	AFE200-73150-KXX-./.-MS 06 AFE200-73150-KXX-./.-SL	
710kW	AFE200-73550-KXX-./.-MS 07 AFE200-73550-KXX-./.-SL	
900kW	AFE200-73150-KXX-./.-MS 09 AFE200-73150-KXX-./.-SL AFE200-73150-KXX-./.-SL	18 x M6 x 16 mm screws + Grover (spring-lock) washer + Flat washer
1MW	AFE200-73550-KXX-./.-MS 10 AFE200-73550-KXX-./.-SL AFE200-73550-KXX-./.-SL	
1.35 MW	AFE200-73550-KXX-./.-MS 14 AFE200-73550-KXX-./.-SL2 AFE200-73550-KXX-./.-SL AFE200-73550-KXX-./.-SL	24 x M6 x 16 mm screws + Grover (spring-lock) washer + Flat washer
1.65 MW	AFE200-73550-KXX-./.-MS 17 AFE200-73550-KXX-./.-SL2 AFE200-73550-KXX-./.-SL2 AFE200-73550-KXX-./.-SL AFE200-73550-KXX-./.-SL	30 x M6 x 16 mm screws + Grover (spring-lock) washer + Flat washer

Note!

Other dimensions [see chapter 10.8](#) Weight and dimensions.

5 - Wiring Procedure

AFE are electrical apparatus for use in industrial installations. Parts of the AFE are energized during operation. The electrical installation and the opening of the device should therefore only be carried out by qualified personnel. Improper installation of motors or AFE may therefore cause the failure of the device as well as serious injury to persons or material damage. Drive is not equipped with motor overspeed protection logic other than that controlled by software. Follow the instructions given in this manual and observe the local and national safety regulations applicable.

Les AFE à fréquence variable sont des dispositifs électriques utilisés dans des installations industrielles. Une partie des AFE sont sous tension pendant l'opération. L'installation électrique et l'ouverture des AFE devrait être exécuté uniquement par du personnel qualifié. De mauvaises installations de moteurs ou de AFE peuvent provoquer des dommages matériels ou blesser des personnes. On doit suivre les instructions données dans ce manuel et observer les règles nationales de sécurité.

Replace all covers before applying power to the AFE. Failure to do so may result in death or serious injury.

Remettre tous les capots avant de mettre sous tension le AFE. Des erreurs peuvent provoquer de sérieux accidents ou même la mort.



Warning!

The AFE must always be grounded. If the AFE is not connected correctly to ground, extremely hazardous conditions may be generated that may result in death or serious injury.

Le AFE doit toujours être raccordé au système de mise à la terre. Un mauvais raccordement du AFE au système de mise à la terre peut se traduire par des conditions extrêmement dangereuses susceptibles d'entraîner le décès ou de graves lésions corporelles.

Never open the device or covers while the AC Input power supply is switched on. Minimum time to wait before working on the terminals or inside the device is listed in section "10.7 Voltage level of AFE200 for safe operations" .

Ne jamais ouvrir l'appareil lorsqu'il est sous tension. Le temps minimum d'attente avant de pouvoir travailler sur les bornes ou bien à l'intérieur de l'appareil est indiqué dans la section 10.7.

Do not touch or damage any components when handling the device. The changing of the isolation gaps or the removing of the isolation and covers is not permissible.

Manipuler l'appareil de façon à ne pas toucher ou endommager des parties. Il n'est pas permis de changer les distances d'isolement ou bien d'enlever des matériaux isolants ou des capots.



Caution

Do not connect power supply voltage that exceeds the standard specification voltage fluctuation permissible. If excessive voltage is applied to the Drive, damage to the internal components will result.

Ne pas raccorder de tension d'alimentation dépassant la fluctuation de tension permise par les normes. Dans le cas d'une alimentation en tension excessive, des composants internes peuvent être endommagés.

Operation with Residual Current Device

If an RCD (also referred to as ELCB or RCCB) is fitted, the inverters will operate without nuisance tripping, provided that:

- a type B RCD is used.
- the trip limit of the RCD is 300mA.
- the neutral of the supply is grounded (TT or TN systems)

- only one AFE200 is supplied from each RCD.
- the output cables are less than 50m (screened) or 100m (unscreened).

RCD: Residual Current Device
RCCB: Residual Current Circuit Breaker
ELCB: Earth Leakage Circuit Breaker

Note: The residual current operated circuit-breakers used must provide protection against direct-current components in the fault current and must be suitable for briefly suppressing power pulse current peaks. It is recommended to protect the AFE200 by fuse separately.
The regulations of the individual country (e.g. VDE regulations in Germany) and the regional power suppliers must be observed!

Fonctionnement avec un dispositif de courant résiduel

En cas d'installation d'un RCD – dispositif de courant résiduel – (également dénommé RCCB ou ELCB), les onduleurs fonctionneront sans faux arrêt à condition que :

- le RCD utilisé soit de type B
- le seuil de déclenchement du RCD soit fixé à 300 mA
- le neutre du bloc d'alimentation soit mis à la terre (systèmes TT ou TN)
- chaque RCD n'alimente qu'un seul onduleur
- la longueur des câbles de sortie soit inférieure à 50 m (blindés) ou 100 m (non blindés)

*RCD: Dispositif de courant résiduel
RCCB: Disjoncteur à courant résiduel
ELCB: Disjoncteur contre fuite à la terre*

Remarque : Les RCD utilisés doivent assurer la protection contre les composants à courant continu présents dans le courant de défaut et doivent être capables de supprimer des crêtes de courant en peu de temps. Il est recommandé de protéger séparément l'AFE200 de fusibles.
Respecter la réglementation des pays concernés (par exemple, les normes VDR en Allemagne) et des fournisseurs locaux d'énergie électrique.



Functioning of the AFE without a ground connection is not permitted.

Défense de faire fonctionner le AFE sans qu'il y ait eu raccordement de mise à la terre préalable

The grounding connector shall be sized in accordance with the NEC or Canadian Electrical Code. The connection shall be made by a UL listed or CSA certified closed-loop terminal connector sized for the wire gauge involved. The connector is to be fixed using the crimp tool specified by the connector manufacturer.

Le raccordement devrait être fait par un connecteur certifié et mentionné à boucle fermée par les normes CSA et UL et dimensionné pour l'épaisseur du câble correspondant. Le connecteur doit être fixé à l'aide d'un instrument de serrage spécifié par le producteur du connecteur.

Do not perform a megger test between the AFE terminals or on the control circuit terminals.

Ne pas exécuter un test megger entre les bornes du AFE ou entre les bornes du circuit de contrôle.

The electrical commissioning should only be carried out by qualified personnel, who are also responsible for the provision of a suitable ground connection and a protected power supply feeder in accordance with the local and national regulations.

La mise en service électrique doit être effectuée par un personnel qualifié. Ce dernier est responsable de l'existence d'une connexion de terre adéquate et d'une protection des câbles d'alimentation selon les prescriptions locales et nationales.

If the AFE have been stored for longer than two years, the operation of the DC link

capacitors may be impaired and must be “reformed”. Before commissioning devices that have been stored for long periods, connect them to a power supply for two hours with no load connected in order to regenerate the capacitors (the input voltage has to be applied without enabling the AFE).

En cas de stockage des variateurs pendant plus de deux ans, il est conseillé de contrôler l'état des condensateurs CC avant d'en effectuer le branchement. Avant la mise en service des appareils, ayant été stockés pendant long temps, il faut alimenter variateurs à vide pendant deux heures, pour régénérer les condensateurs : appliquer une tension d'alimentation sans actionner le AFE.

Type of networks

AFE are designed to be powered from standard three phase lines that are electrically symmetrical with respect to ground (TN or TT network). It is possible the use with IT network. In case of use of networks at 690Vac, all AFE200-6 sizes with the use of standard filters (EMI-FN3359HV series) can be utilized.

For the series 400/480V (AFE200-4), only the size 4450 and 5900 must be requested specifically for use for IT networks (AFE200-4-IT series).

All AFE200-4 requires the use of special EMC filters for IT networks (on request).

Power supply networks

Based on the grounding method, the IEC 60634-1 describes three main types of grounding for power supply networks: TN, TT and IT systems.

In particular, the IT system has all the active parts insulated from earth or a point connected to ground through an impedance. The earths of the system are connected separately or collectively to the system ground.

The following figures show these different systems.

TN-S supply lines

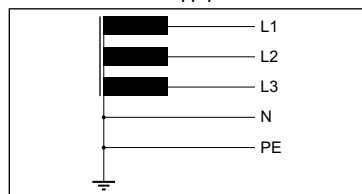

TN-C supply lines

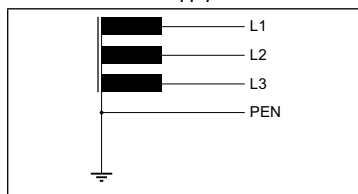

TT supply lines

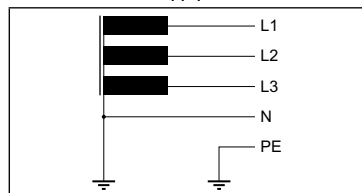



IT supply lines



5.1 Power section

5.1.1 Cable Cross Section

Sizes AFE200-...-4	Terminals: C - D - U - V - W			
	Maximum Cable Cross Section (flexible conductor)		Recommended stripping	Tightening torque (min)
	(mm ²)	AWG	(mm)	(Nm)
3220	16	6	14	1.5 ... 1.7
4450	35	2	18	2.4 ... 4.5
5900	95	4/0	23	14
61320	240	500	40	40
Sizes AFE200-...-4	Bars: C - D - U - V - W			
	Recommended cable cross-section		Lock screw diameter	Tightening torque (min)
	(mm ²)	AWG / kcmil	(mm)	(Nm)
71600	2 x 100	2 x AWG 4/0	M10	50
72000	2 x 100	2 x AWG 4/0	M10	50
72500	2 x 150	2 x kcmil 300	M10	50
73150	2 x 185	2 x kcmil 350	M10	50
73550	2 x 185	2 x kcmil 350	M10	50

Sizes AFE200-...-4	Terminals:  on mechanical cabinet				
	Cable Cross Section		Lock screw diameter	Recommended terminal	Tightening torque
	(mm ²)	AWG / kcmil	(mm)		(Nm)
3220 ... 4450	16	AWG 6	M6	Eyelet - Spade	10
5900	50	AWG 1/0	M6	Eyelet - Spade	10
61320	120	250 kcmil	M8	Eyelet - Spade	24
71600 ... 72500	Terminals:  on bars				
	150	300 kcmil	M10	Eyelet	50
	185	350 kcmil	M10	Eyelet	50

Sizes AFE200-...-4		Bars: C - D - U - V - W			
		Recommended cable cross-section		Lock screw diameter	Tightening torque (min)
		(mm ²)	AWG / kcmil	(mm)	(Nm)
400kW	72000-KXX-4-MS 04	2 x 100	2 x AWG 4/0	M10 (U,V,W=M12)	50 (M10) / 75 (M12)
	72000-XXX-4-SL	2 x 100	2 x AWG 4/0	M10 (U,V,W=M12)	50 (M10) / 75 (M12)
500kW	72500-KXX-4-MS 05	2 x 150	2 x kcmil 300	M10 (U,V,W=M12)	50 (M10) / 75 (M12)
	72500-XXX-4-SL	2 x 150	2 x kcmil 300	M10 (U,V,W=M12)	50 (M10) / 75 (M12)
630kW	73150-KXX-4-MS 06	2 x 185	2 x kcmil 350	M10 (U,V,W=M12)	50 (M10) / 75 (M12)
	73150-XXX-4-SL	2 x 185	2 x kcmil 350	M10 (U,V,W=M12)	50 (M10) / 75 (M12)
710kW	73550-KXX-4-MS 07	2 x 185	2 x kcmil 350	M10 (U,V,W=M12)	50 (M10) / 75 (M12)
	73550-XXX-4-SL	2 x 185	2 x kcmil 350	M10 (U,V,W=M12)	50 (M10) / 75 (M12)
900kW	73150-KXX-4-MS 09	2 x 185	2 x kcmil 350	M10 (U,V,W=M12)	50 (M10) / 75 (M12)
	73150-XXX-4-SL	2 x 185	2 x kcmil 350	M10 (U,V,W=M12)	50 (M10) / 75 (M12)
	73150-XXX-4-SL	2 x 185	2 x kcmil 350	M10 (U,V,W=M12)	50 (M10) / 75 (M12)

Sizes AFE200-...-4		Bars: C - D - U - V - W			
		Recommended cable cross-section		Lock screw diameter	Tightening torque (min)
		(mm ²)	AWG / kcmil	(mm)	(Nm)
1MW	AFE200-73550-KXX-4-MS 10	2 x 185	2 x kcmil 350	M10 (U,V,W=M12)	50 (M10) / 75 (M12)
	AFE200-73550-XXX-4-SL	2 x 185	2 x kcmil 350	M10 (U,V,W=M12)	50 (M10) / 75 (M12)
	AFE200-73550-XXX-4-SL	2 x 185	2 x kcmil 350	M10 (U,V,W=M12)	50 (M10) / 75 (M12)

Sizes AFE200-...-4		Terminals:  on mechanical cabinet				
		Recommended cable cross-section		Lock screw diameter	Recommended terminal	Tightening torque (min)
		(mm ²)	AWG / kcmil	(mm)		(Nm)
400kW	72000-KXX-4-MS 04	150	300 kcmil	M10	Eyelet	50
	72000-XXX-4-SL	150	300 kcmil	M10	Eyelet	50
500kW	72500-KXX-4-MS 05	150	300 kcmil	M10	Eyelet	50
	72500-XXX-4-SL	150	300 kcmil	M10	Eyelet	50
630kW	73150-KXX-4-MS 06	185	350 kcmil	M10	Eyelet	50
	73150-XXX-4-SL	185	350 kcmil	M10	Eyelet	50
710kW	73550-KXX-4-MS 07	185	350 kcmil	M10	Eyelet	50
	73550-XXX-4-SL	185	350 kcmil	M10	Eyelet	50
900kW	73150-KXX-4-MS 09	185	350 kcmil	M10	Eyelet	50
	73150-XXX-4-SL	185	350 kcmil	M10	Eyelet	50
	73150-XXX-4-SL	185	350 kcmil	M10	Eyelet	50
1MW	AFE200-73550-KXX-4-MS 10	185	350 kcmil	M10	Eyelet	50
	AFE200-73550-XXX-4-SL	185	350 kcmil	M10	Eyelet	50
	AFE200-73550-XXX-4-SL	185	350 kcmil	M10	Eyelet	50

Sizes AFE200-...-6	Bars: C - D - U - V - W			
	Recommended cable cross-section		Lock screw diameter	Tightening torque (min)
	(mm ²)	AWG / kcmil	(mm)	(Nm)
71600	95	AWG 4/0	M10	50
72000	150	300 kcmil	M10	50
72500	240	500 kcmil	M10	50
73150 - 73550	2 x 100	2 x AWG 4/0	M10	50

Sizes AFE200-...-6	Terminals: $\frac{1}{2}$ on bars				
	Cable Cross Section		Lock screw diameter	Recommended terminal	Tightening torque
	(mm ²)	AWG / kcmil	(mm)		(Nm)
71600	50	AWG 1/0	M10	Eyelet	50
72000	75	AWG 2/0	M10	Eyelet	50
72500	120	250 kcmil	M10	Eyelet	50
73150 - 73550	150	300 kcmil	M10	Eyelet	50

Sizes AFE200-...-6		Bars: C - D - U - V - W			
		Recommended cable cross-section		Lock screw diameter	Tightening torque (min)
		(mm ²)	AWG / kcmil	(mm)	(Nm)
400kW	72000-KXX-6-MS 04	150	300 kcmil	M10	50
	72000-KXX-6-SL	150	300 kcmil	M10	50
500kW	72500-KXX-6-MS 05	240	500 kcmil	M10	50
	72500-KXX-6-SL	240	500 kcmil	M10	50
630kW	73150-KXX-6-MS 06	2 x 100	2 x AWG 4/0	M10	50
	73150-KXX-6-SL	2 x 100	2 x AWG 4/0	M10	50
710kW	73550-KXX-6-MS 07	2 x 100	2 x AWG 4/0	M10	50
	73550-KXX-6-SL	2 x 100	2 x AWG 4/0	M10	50
900kW	73150-KXX-6-MS 09	2 x 100	2 x AWG 4/0	M10	50
	73150-KXX-6-SL	2 x 100	2 x AWG 4/0	M10	50
	73150-KXX-6-SL	2 x 100	2 x AWG 4/0	M10	50
1MW	AFE200-73550-KXX-6-MS 10	2 x 100	2 x AWG 4/0	M10	50
	AFE200-73550-KXX-6-SL	2 x 100	2 x AWG 4/0	M10	50
	AFE200-73550-KXX-6-SL	2 x 100	2 x AWG 4/0	M10	50
1.35MW	AFE200-73550-KXX-6-MS 14	2 x 100	2 x AWG 4/0	M10	50
	AFE200-73550-KXX-6-SL2	2 x 100	2 x AWG 4/0	M10	50
	AFE200-73550-KXX-6-SL	2 x 100	2 x AWG 4/0	M10	50
	AFE200-73550-KXX-6-SL	2 x 100	2 x AWG 4/0	M10	50
1.65MW	AFE200-73550-KXX-6-MS 17	2 x 100	2 x AWG 4/0	M10	50
	AFE200-73550-KXX-6-SL2	2 x 100	2 x AWG 4/0	M10	50
	AFE200-73550-KXX-6-SL	2 x 100	2 x AWG 4/0	M10	50
	AFE200-73550-KXX-6-SL	2 x 100	2 x AWG 4/0	M10	50

Sizes AFE200-...-6		Connection 				
		Recommended cable cross-section		Lock screw diameter	Recommended terminal	Tightening torque (min)
		(mm ²)	AWG / kcmil	(mm)		(Nm)
400kW	72000-KXX-6-MS 04	75	AWG 2/0	M10	Eyelet	50
	72000-XXX-6-SL	75	AWG 2/0	M10	Eyelet	50
500kW	72500-KXX-6-MS 05	120	250 kcmil	M10	Eyelet	50
	72500-XXX-6-SL	120	250 kcmil	M10	Eyelet	50
630kW	73150-KXX-6-MS 06	150	300 kcmil	M10	Eyelet	50
	73150-XXX-6-SL	150	300 kcmil	M10	Eyelet	50
710kW	73550-KXX-6-MS 07	150	300 kcmil	M10	Eyelet	50
	73550-XXX-6-SL	150	300 kcmil	M10	Eyelet	50
900kW	73150-KXX-6-MS 09	150	300 kcmil	M10	Eyelet	50
	73150-XXX-6-SL	150	300 kcmil	M10	Eyelet	50
	73150-XXX-6-SL	150	300 kcmil	M10	Eyelet	50
1MW	AFE200-73550-KXX-6-MS 10	150	300 kcmil	M10	Eyelet	50
	AFE200-73550-XXX-6-SL	150	300 kcmil	M10	Eyelet	50
	AFE200-73550-XXX-6-SL	150	300 kcmil	M10	Eyelet	50
1.35MW	AFE200-73550-KXX-6-MS 14	150	300 kcmil	M10	Eyelet	50
	AFE200-73550-XXX-6-SL2	150	300 kcmil	M10	Eyelet	50
	AFE200-73550-XXX-6-SL	150	300 kcmil	M10	Eyelet	50
	AFE200-73550-XXX-6-SL	150	300 kcmil	M10	Eyelet	50
1.65MW	AFE200-73550-KXX-6-MS 17	150	300 kcmil	M10	Eyelet	50
	AFE200-73550-XXX-6-SL2	150	300 kcmil	M10	Eyelet	50
	AFE200-73550-XXX-6-SL2	150	300 kcmil	M10	Eyelet	50
	AFE200-73550-XXX-6-SL	150	300 kcmil	M10	Eyelet	50
	AFE200-73550-XXX-6-SL	150	300 kcmil	M10	Eyelet	50

5.1.2 EMC guide line



.....
In a domestic environment, this product may cause radio interference, in which case supplementary mitigation measures may be required.

Dans un environnement domestique, ce produit peut causer des interférences radio, auquel cas supplémentaire des mesures d'atténuation peuvent être nécessaires.
.....



.....
AFE are designed to operate in an industrial environment where a high level of electromagnetic interference are to be expected. Proper installation practices will ensure safe and trouble-free operation. If you encounter problems, follow the guidelines which follow.

- Check for all equipment in the cabinet are well grounded using short, thick grounding cable connected to a common star point or busbar. Better solution is to use a conductive mounting plane and use that as EMC ground reference plane.
- Flat conductors, for EMC grounding, are better than other type because they have lower impedance at higher frequencies.
- Make sure that any control equipment (such as a PLC) connected to the AFE200 is connected to the same EMC ground or star point as the AFE200 via a short thick link.
- Separate the control cables from the power cables as much as possible, using separate trunking, if necessary at 90° to each other.
- Whenever possible, use screened leads for the connections to the control circuitry.
- Ensure that the contactors in the cubicle are suppressed, either with R-C suppressors for AC contactors or 'flywheel' diodes for DC contactors fitted to the coils. Varistor suppressors are also effective. This is important when the contactors are controlled from the AFE200 relay.
- Use screened or armored cables for the U-V-W connections and ground the screen at both ends using the cable clamps
- Use the recommended EMI filters, which are listed in section 11.3 of this manual (conformity with EN61800-3, class C3 with 50 meters of motor cable with a single inverter supplied by the AFE200).
- Use shielded cables in motors to ensure the correct operation of the EMI filter.

Note!

.....
For further information regarding electro-magnetic compatibility standards, according to Directive 2014/30/EC, conformity checks carried out on Gefran appliances, connection of filters and mains inductors, shielding of cables, ground connections, etc., consult the "Electro-magnetic compatibility guide" on the CD attached to this product.
.....

5.1.3 Block diagram power section

AFE200-3220 ... 73550

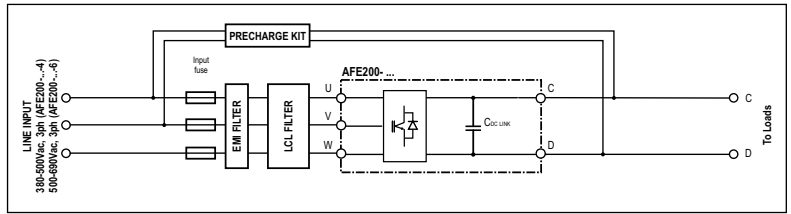

AFE200 : 400kW - 710kW

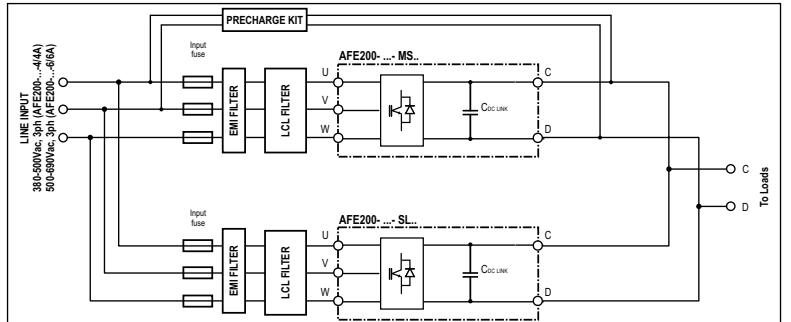

AFE200 : 900kW - 1MW

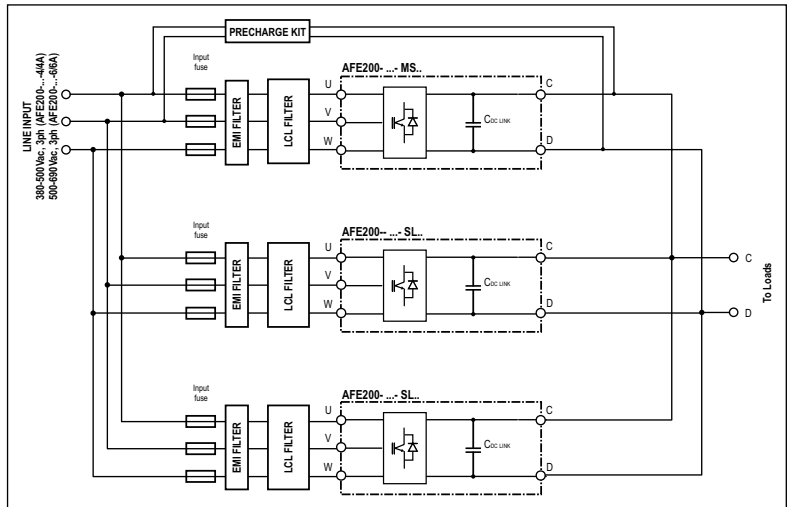

AFE200 : 1.35MW

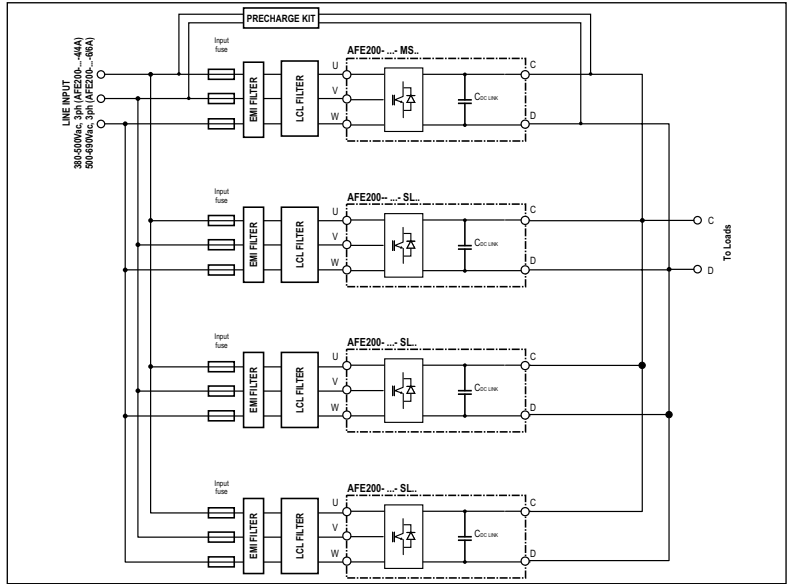

AFE200 : 1.65MW

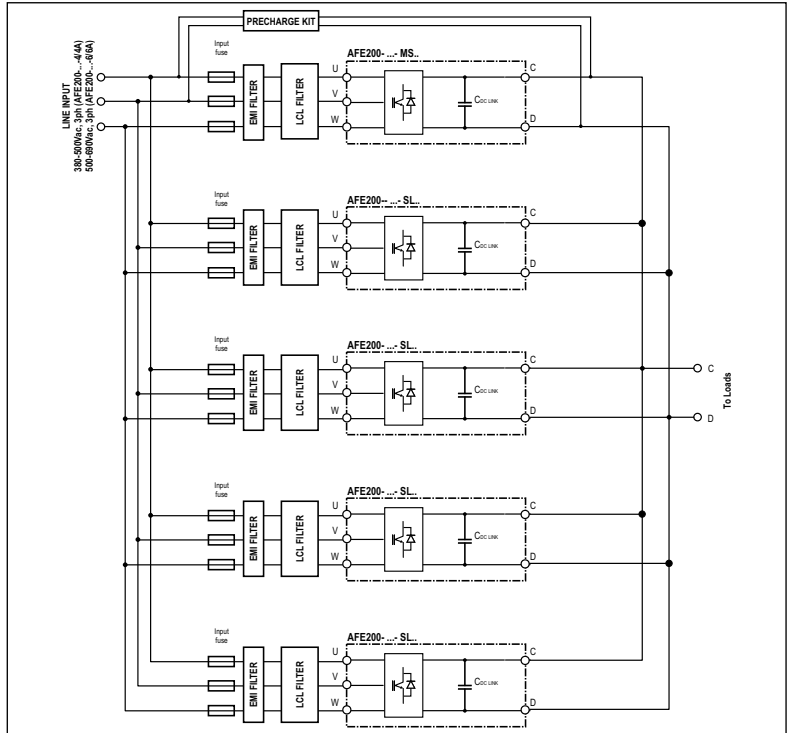

5.1.4 Power line connection

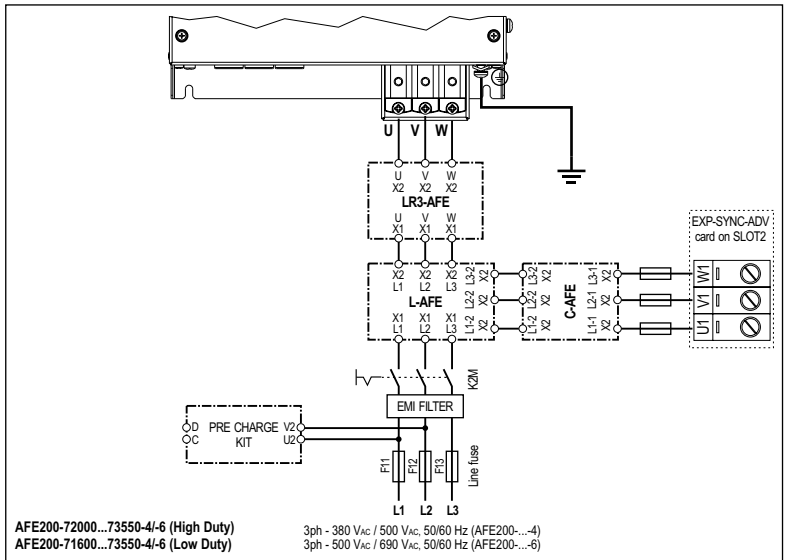
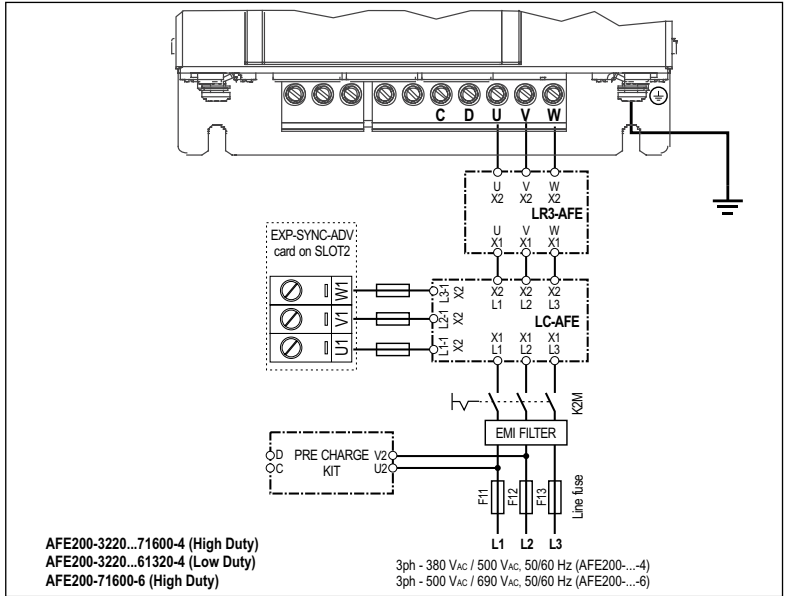

Note!

Recommended combination F1 fuses: see [paragraph 11.1](#).

5.1.5 DC output connection

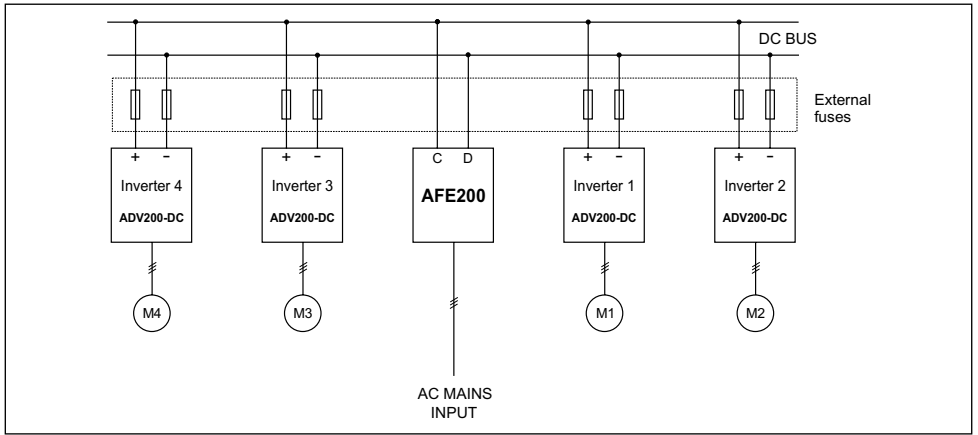

AFE200-3220 ... 4450

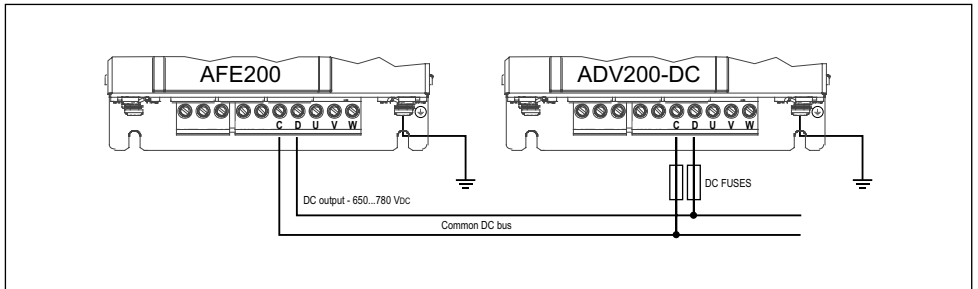

AFE200-5900 ... 61320

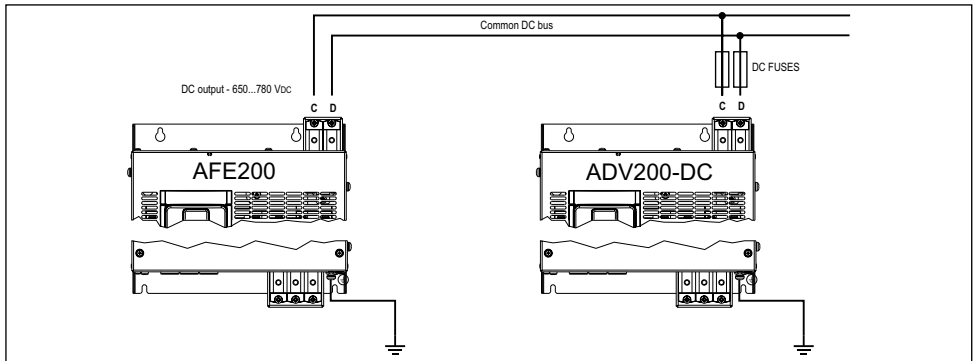

AFE200-71600 ... 73550

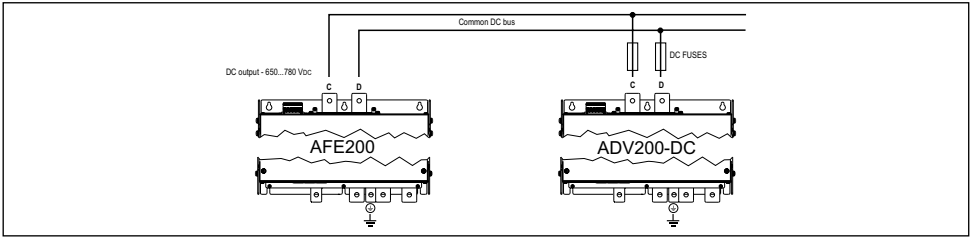

AFE200 : 400kW ... 710kW

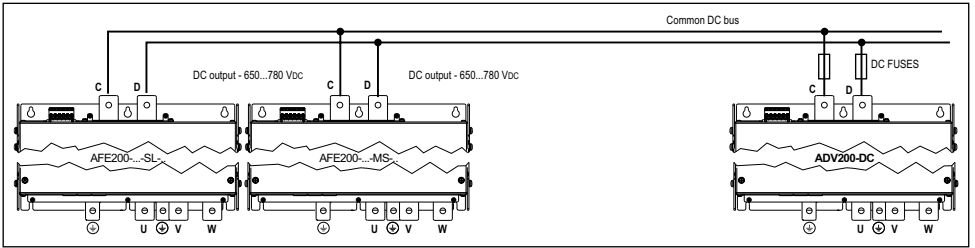

AFE200 : 900kW - 1MW

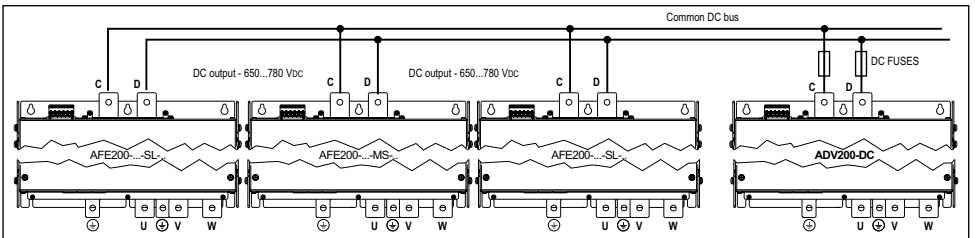

AFE200 : 1.35 MW

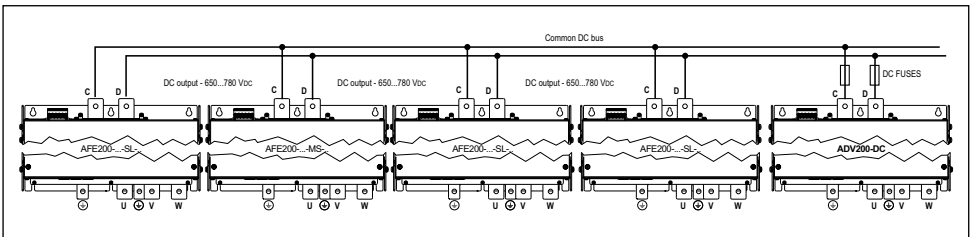

AFE200 : 1.65 MW

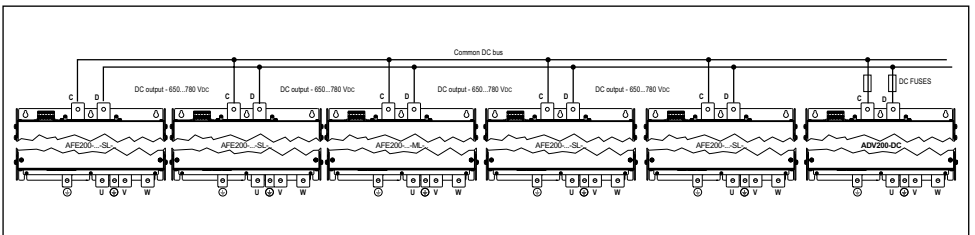

5.1.6 Connection of fans power supply

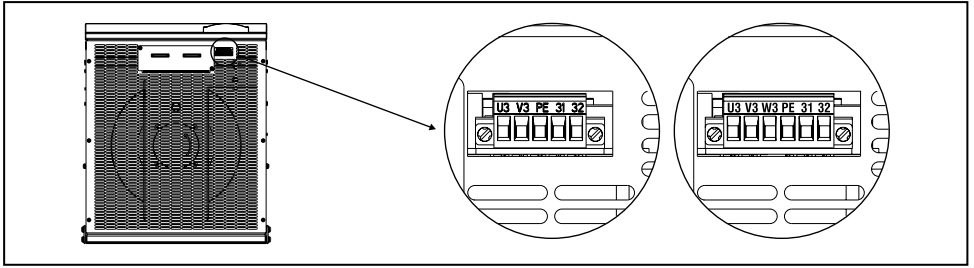

Sizes	Terminals
3220 ... 61320	No connection is necessary: the AFE's internal power supply unit powers the fan (+ 24Vac).

Terminals	Version before 2009/125/CE (ErP regulation)					
	U3	V3	PE	31	32	
Sizes 71600 ... 72500 400 kW (1) 500 kW (1) (1) For each module.	1 x 230V ($\pm 10\%$) 50/60Hz, 2.4A (50Hz) - 3.3A (60Hz)		Ground	250V/10A contact OK fan contact management terminals 31-32: Closed: Internal fan OK and powered; Open: Internal fan in over temperature alarm and/or input power supply not available.		
	Power the internal fan (max 600W) with a single-phase voltage on terminals U3/V3.					
	Type of fan compliant 2009/125/CE (ErP) AFE200 starting from S/N 33GD018605					
	U3	V3	W3	PE	31	32
3 x 400V ($\pm 10\%$) 50/60Hz, 1.25/1.65Arms ...		3 x 460V ($\pm 10\%$) 60Hz, 1.55Arms		Ground	250V/2A contact OK fan contact management terminals 31-32: Closed: Internal fan OK (also with non-powered fan) Open: Internal fan in over temperature alarm	
Power the internal fan (570W @400V, 930W @460V) with a three-phase voltage on terminals U3/V3/W3.						

Terminals	Version before 2009/125/CE (ErP regulation)					
	U3	V3	W3	PE	31	32
Sizes 73150 ... 73550 630 kW (1) 710 kW (1) 900 kW (1) 1 MW (1) (1) For each module.	3 x 400V ($\pm 10\%$) 50Hz, 1,55Arms		or		3 x 460V ($\pm 10\%$) 60Hz, 1,7Arms	
			Ground		250V/10A contact OK fan contact management terminals 31-32: Closed: Internal fan OK (also with non-powered fan) Open: Internal fan in over temperature alarm	
	Power the internal fan (max 1200W) with a three-phase voltage on terminals U3/V3/W3.					
	Type of fan compliant 2009/125/CE (ErP) AFE200 starting from S/N 33GD018605					
3 x 380...480V ($\pm 10\%$) 50/60Hz, 1.9 ... 1.7 Arms				Ground	250V/10A contact OK inverter fan contact management terminals 31-32: Closed: Inverter fan OK and powered; Open: Inverter fan in alarm or not supplied.	
Power the internal fan (max 1200W) with a three-phase voltage on terminals U3/V3/W3.						



Make sure the sequence of the three-phase fan power supply phases is the same as that shown on the relative AFE terminals. If not, the air flow will be inadequate to ensure correct cooling..

5.2 Regulation section

5.2.1 Removing the terminal cover



When removing the covers be careful to lateral metal sheet enclosure. Presence of sharp edge are possible.

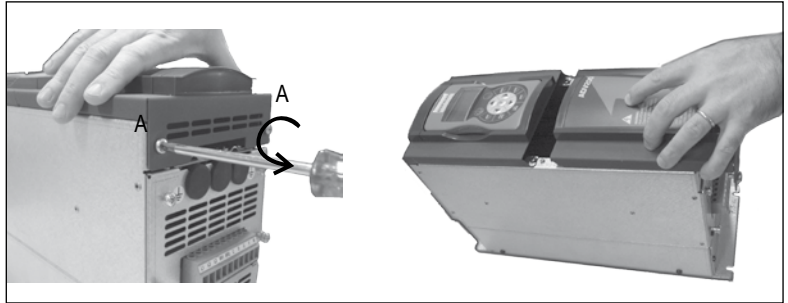

5.2.2 Cable Cross Section

Terminal strips (Regulation card)	Maximum Cable Cross Section		Recommended stripping (mm)	Tightening torque (min) (min) (Nm)
	(mm ²)	(AWG)		
	0.2 ... 2.5	24 ... 12	7	0.5

5.2.3 Regulation section connection

Figure 5.2.3.1: Regulation shielding

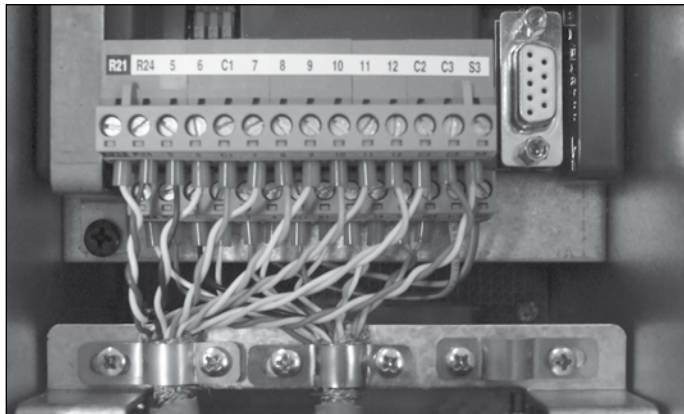

For shielding of the regulation section (recommended), fasten the shield of the cables to the omega sections (see figure above).

Table 5.2.3.1: Regulation terminals

Strip T2 (top)			
Terminal	Designation	Function	Max
R21	COM Digital output 2	Common reference for digital output 2 (Relay 2)	-
R24	Digital output 2	Programmable digital relay output 2 (NO). Default = Drive ready (PAR 1064)	250 Vac - 30 Vbc / 2A
5	Analog output 1	Analog output 1. Default = Null (PAR 6000)	±12,5 V (typical ±10 V / 5 mA)
6	Analog output 2	Analog output 2. Default = Null (PAR 6000)	- voltage (default): ±12,5 V (typical ±10V/5mA) - current (set by S3 switch): 0...20mA or 4...20mA (setting by PAR 1848, 15 - ANALOG OUPUTS menu)
C1	COM Analog output	Common reference for analog outputs and ±10V potential voltage reference	-
7	Digital input E	Digital input E. Default = Digital input E mon, PAR 1110 (Enable)	5mA @ +24V (+30V max)
8	Digital input 1	Digital input 1. Default = Precharge fbk src (PAR 4498)	5mA @ +24V (+30V max)
9	Digital input 2	Digital input 2. Default . Default = Null (PAR 6000)	5mA @ +24V (+30V max)
10	Digital input 3	Digital input 3. Default . Default = Null (PAR 6000)	5mA @ +24V (+30V max)
11	Digital input 4	Digital input 4. Default . Default = Null (PAR 6000)	5mA @ +24V (+30V max)
12	Digital input 5	Digital input 5. Default = Fault reset src (PAR 4500)	5mA @ +24V (+30V max)
C2	COM Digital inputs	Common reference for digital inputs	-
C3	0V 24 OUT	+24V supply for IO	150 mA (Resettable fuse), ±10 %
S3	+ 24V OUT	Reference point for +24V OUT	-

Strip T1 (bottom)			
Terminal	Designation	Function	Max
R11	COM Digital output 1	Common reference for digital output 1 (Relay 1)	-
R14	Digital output 1	Programmable digital relay output 1 (NO). Default = Precharge Command (PAR 1122)	250 Vac - 30 Vbc / 2A
1	Analog input 1	Programmable / configurable analog differential input. Signal: terminal 1. Reference: terminal 2. Default = Multi ref 0 src	- voltage (default): ±12,5 V (typical ±10V/1mA) - current (set by switches S1-S2): 0...20mA or 4...20mA (set by PAR 1502 or 1552, 14 - ANALOG INPUTS menu)
2			
3	Analog input 2	Programmable / configurable analog differential input. Signal: terminal 3. Reference: terminal 4. Default = Not used	
4			
S1+	+10 V	Voltage reference +10V; reference point: C1 terminal	+10 V ±1% / 10 mA
S1-	-10V	Analog output -10V; reference point: C1 terminal	-10 V ±1% / 10 mA
13	Digital output 3	Digital output 3. Default = Drive OK (PAR 1062)	+24 V / 20 mA (typ), 40 mA (max)
14	Digital output 4	Digital output 4. Default = Null (PAR 6000)	+24 V / 20 mA (typ), 40 mA (max)
IS1	PS Digital output	Digital outputs 3 / 4 power supply	-
IC1	COM Digital output	Common reference for digital outputs 3 / 4	-
IC2	0V 24 EXT	Reference for regulation card 24V external supply	-
IS2	+ 24V EXT	External supply of regulation card	+24V ±10% / 1A



Caution

.....
+24Vdc voltage, which is used to externally supply the regulation card has to be stabilized and with a maximum ±10% tolerance. The maximum absorption is 1A.

It is not suitable to power supply the regulation card only through a unique rectifier and capacitive filter.

La tension de + 24Vdc utilisée pour alimenter extérieurement la carte de régulation doit être stabilisée avec une tolérance de $\pm 10\%$; absorption maximum de 1A. Les alimentations obtenues avec les seules redresseur e filtre capacitive ne sont pas appropriées.

5.2.4 Switches, jumpers and LED

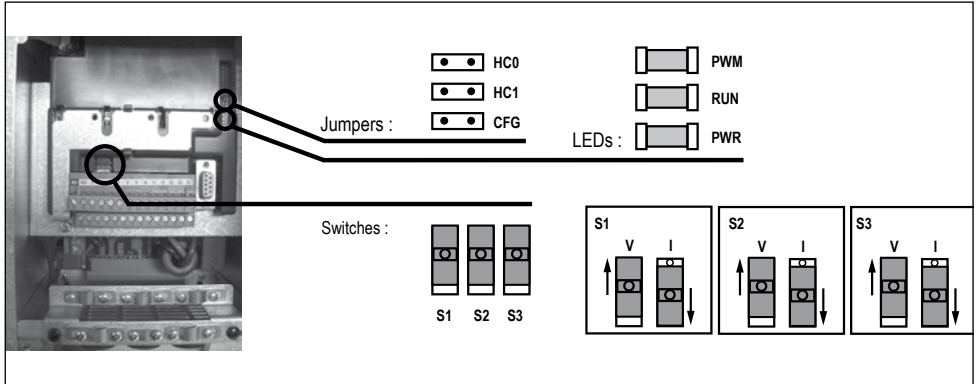

Switch	V/I settings on inputs and analog output
S1	Analog input 1 Default = voltage (± 10 V)
S2	Analog input 2 Default = voltage (± 10 V)
S3	Analog output 2 Default = voltage (± 10 V)

LEDs	Function
PWM (green)	LED lit during IGBT modulation
RUN (green)	Flashes (freq. 1 sec) if no errors or faults have occurred. If ON or OFF, indicates an error conditions (software hangup)
PWR (green)	ON when the regulation card is correctly powered

Jumpers	Function
HC0 HC1	Reserved. Default = Open
CFG	Open = 400 Vac rated voltage (default) Closed = 460 Vac rated voltage

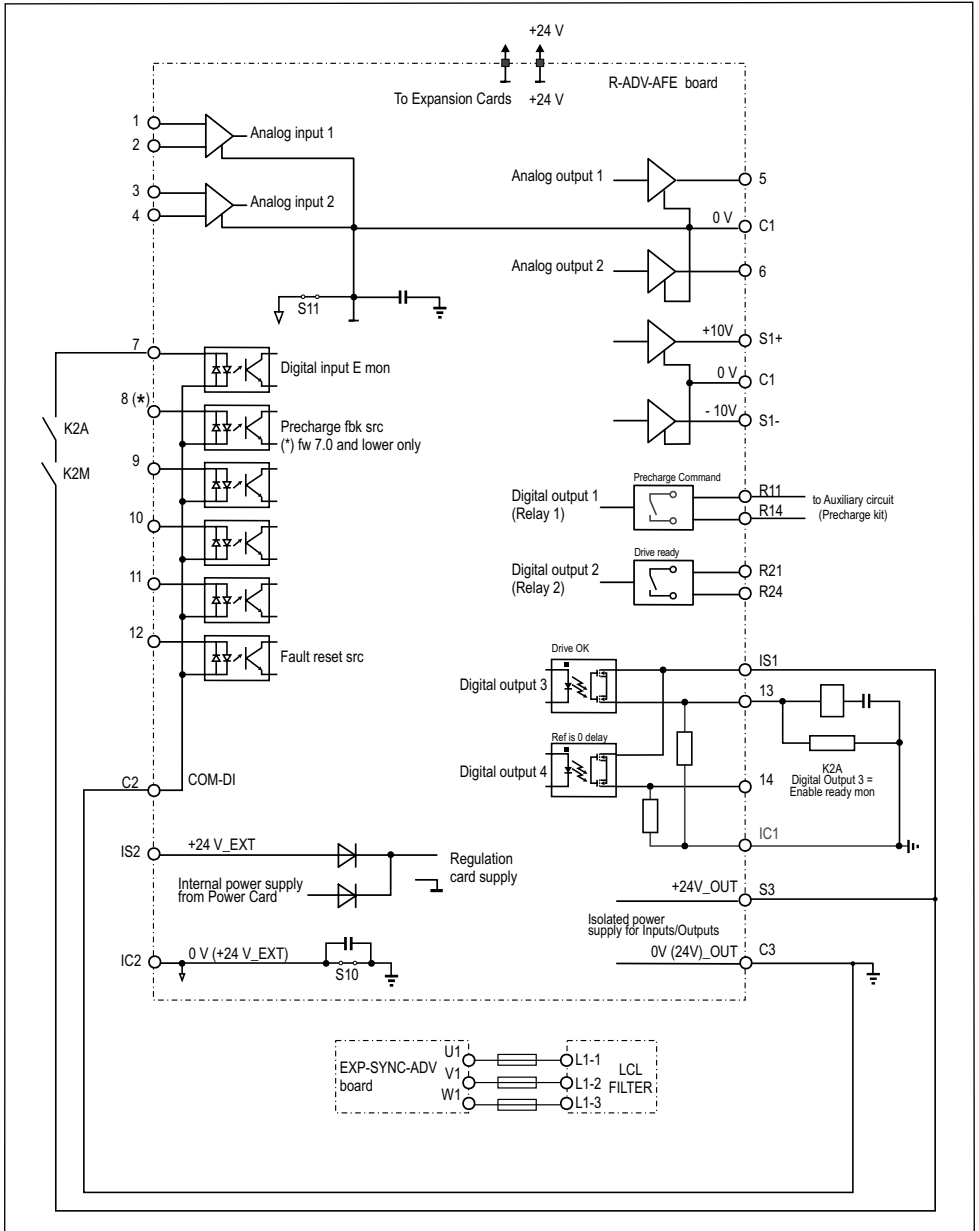
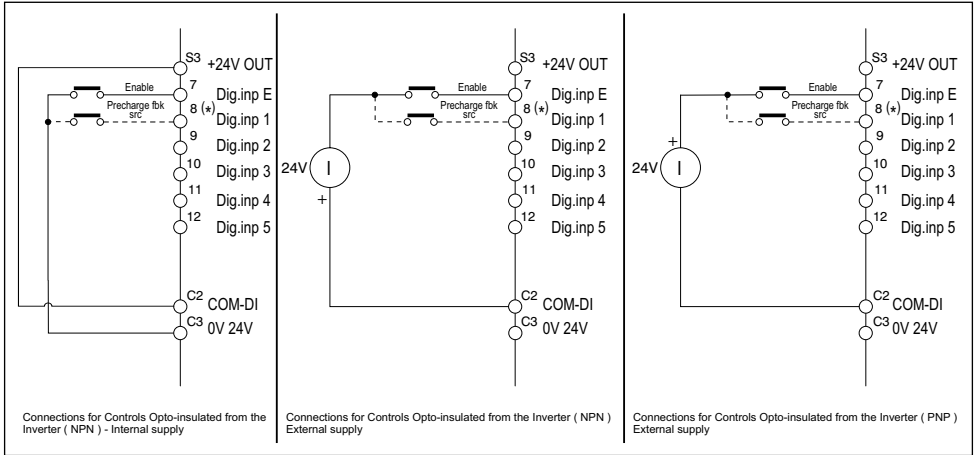

Figure 5.2.4.1: Potentials of the control section. Digital I/O PNP connection



(*) : fw 7.0 and lower only.

Figure 5.2.4.2: Other inputs connections (NPN-PNP)

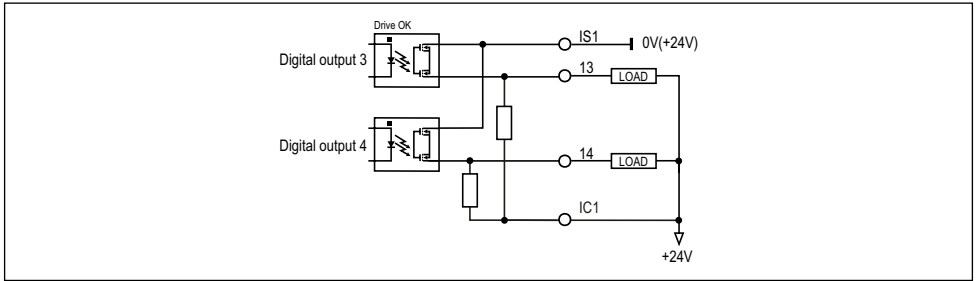
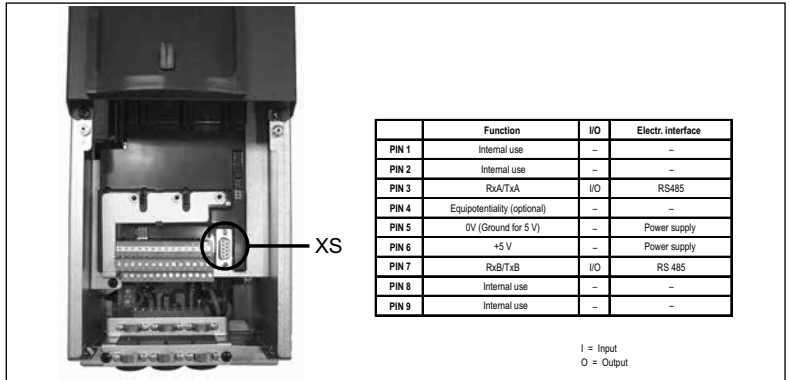

Figure 5.2.4.3: NPN outputs connection

5.3 Serial interface (XS connector)



The AFE200 is equipped as standard with a port (9-pin D-SUB connector: **XS**) for connection of the RS485 serial line used for AFE/PC point-to-point communication (through the GF-eXpress configuration software) or for multi-drop connection.

To access the connector, remove the lower cover as illustrated in shown in [paragraph 5.2.1](#).

5.3.1 AFE / RS 485 Port (not insulated) point-to-point connection



The connection indicated is without galvanic insulation !

Le raccordement indiqué n'a pas d'isolation galvanique !



Figura 5.3.1.1: Serial connection (not insulated)

A twin-pair consisting of two symmetrical conductors, spiral wound with a common shield plus the bonding connection cable, connected as shown in the figure, must be used for connection. The transmission speed is 38.4 kBaud.

For connection of the RS485 serial line to the PC, see the figure below.

The **Modbus** or **Jbus** serial protocol can be selected in the Serial protocol parameter PAR 3804. For more details see the "1S9H63_Modbus_it-en.pdf" instruction manual in the CD supplied with the product.

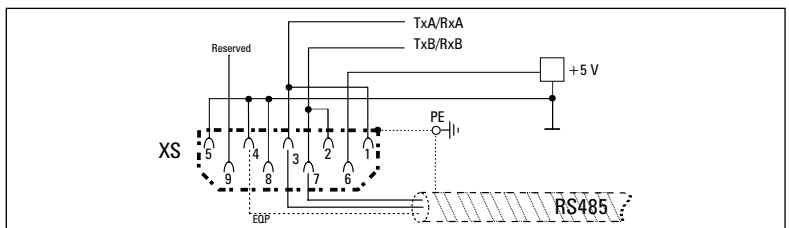
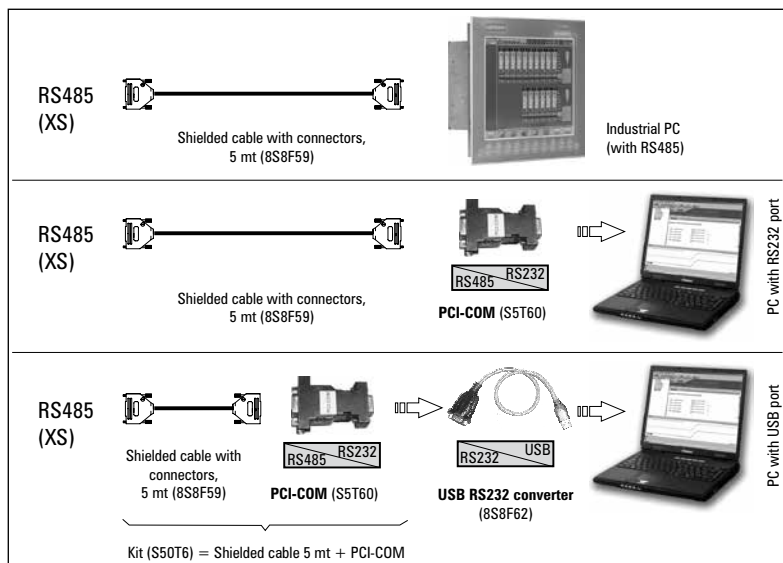

Figure 5.3.1.2: Collegamento RS485 al PC

Connection of an industrial PC with RS485

The following are required for connection:

- shielded cable for the **XS / RS485** connection (see figure 5.3.1.1), code 8S8F59

Connection to a PC with RS232 port

The following are required for connection:

- an optional **PCI-COM** (or PCI-485) adapter, code S560T.
- shielded cable for **XS / PCI-COM** (or PCI-485) connection, code 8S8F59, see figure 5.3.1.1 .

Connection to a PC with USB port

The following are required for connection:

- an optional **PCI-COM** (or PCI-485) adapter, code S560T.
- an optional **USB/ RS232** adapter, code 8S8F62 (including the cable for USB connection)
- shielded cable for the **XS / PCI-COM** (or PCI-485) connection, code 8S8F59, see figure 5.3.1.1 .

5.3.2 AFE / RS485 port point-to-point connection (with insulation)

To make the connection with galvanic isolation, the **OPT-RS485-ADV** optional card is required.

The card is equipped with a 9-pin D-SUB male connector which must be inserted in the **XS** connector of the AFE200.

Connect terminals 1, 2 and 4 to the serial line as shown in the figure below; for the connection from the serial line to the PC, the adapters indicated in paragraph 5.3.1 must be used.

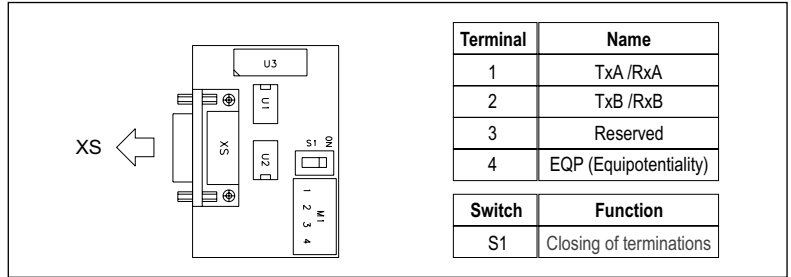
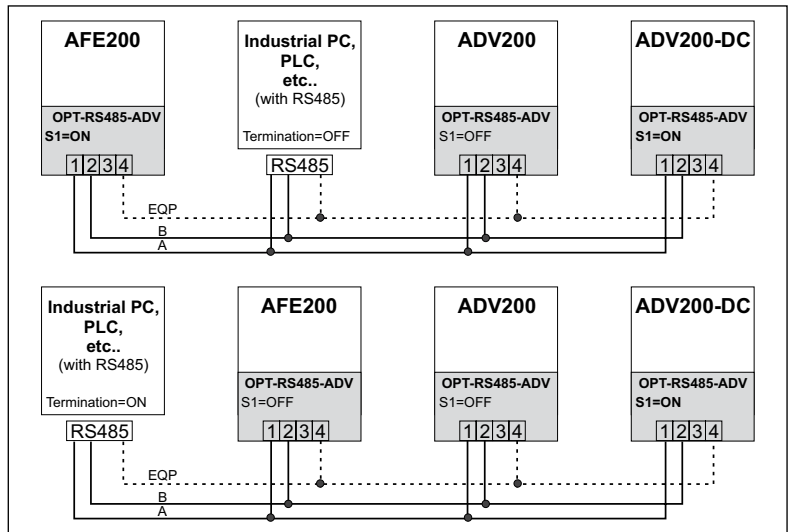

Figure 5.3.2.1: OPT-RS485-ADV card

5.3.3 RS 485 multi-drop connection

For the multi-drop connection, the **OPT-RS485-ADV** optional card must be installed on each drive; the ends of the connection must have **S1** termination switch set to ON. The multi-drop connection is always galvanically insulated.

Up to 20 drives can be connected; the maximum length of the connection is 200 meters.



5.4 Typical connection diagrams (with Pre-charge Kit)

For Sizes:
AFE200-3220...71600-4 (HD)
AFE200-3220...61320-4 (LD)
AFE200-71600-6 (HD)

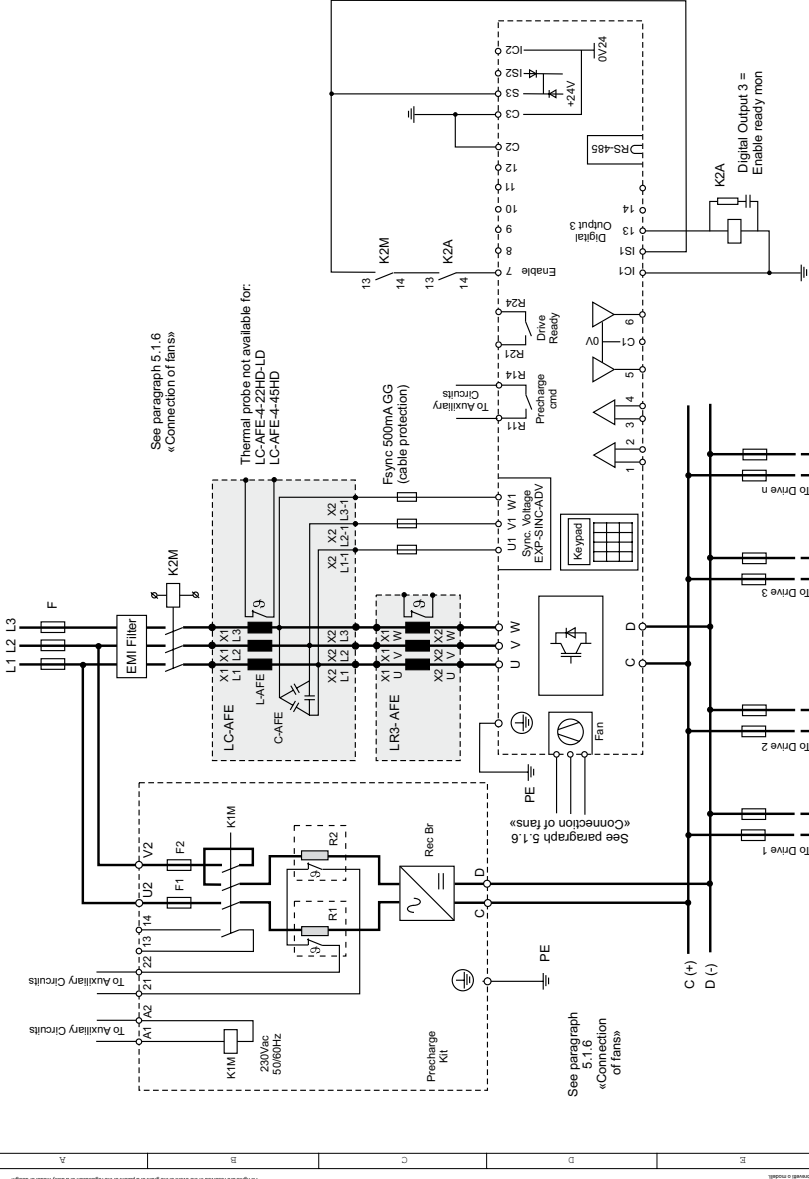

Copyright of this document, and GEF 2000 is a trademark and the logo of GEF 2000. It is forbidden without express written consent. Otherwise see also the paragraph of the manual of design. If the manual is not available in the language of your country, please contact the GEF 2000 representative in your country. © GEF 2000

Rev.	Date	Modification	Description	Des./Sch.	Apprvd	Name	N.F.	Date:	Rev.
						AFE Connection		29-1-2014	00
						LOC.		GEFRAN S.p.A. Via G. Matteotti, 15 37146 Sommacampese (VR)	Page 1 of 1
						Des. / Dig	Func.		1
						Sch.	Appr.		1



For Sizes:
AFE200-72000...73550-4/6 (HD)
AFE200-71600...73550-4/6 (LD)

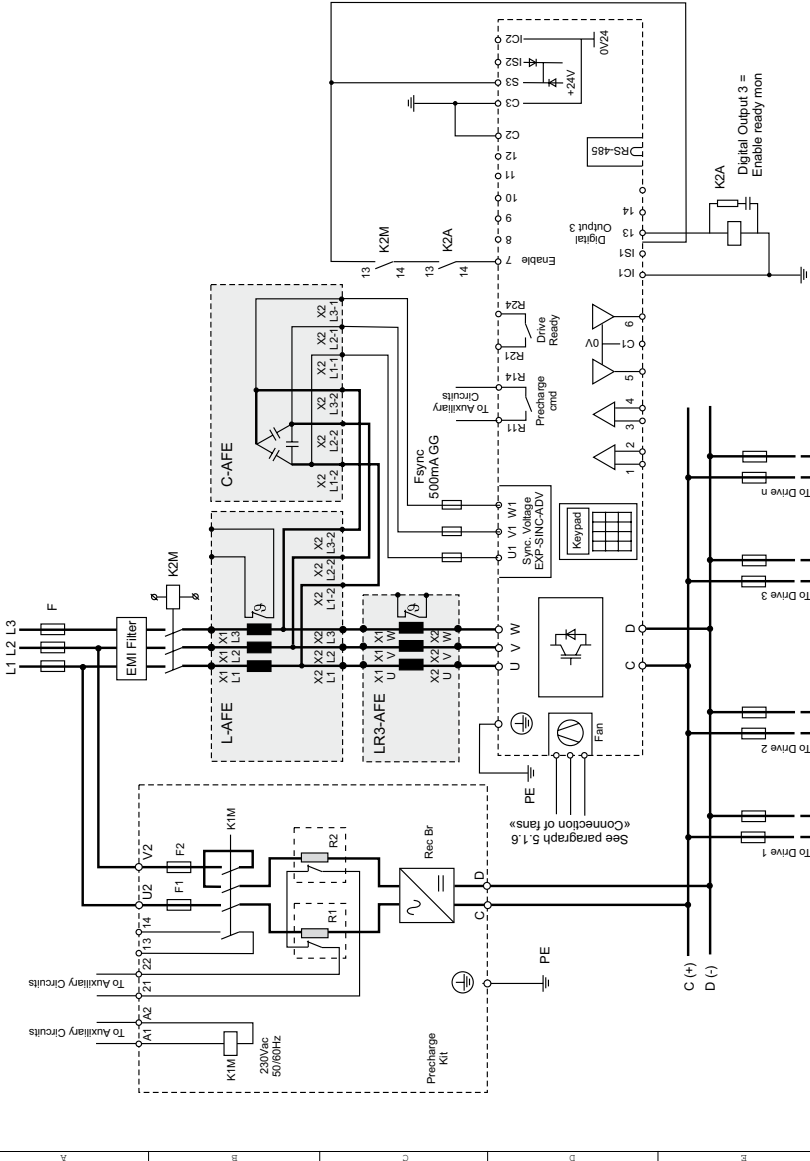

Copyright © GEFFRAN S.p.A. - All rights reserved. No part of this publication may be reproduced, stored in a retrieval system, or transmitted, in any form or by any means, electronic, mechanical, photocopying, recording, or otherwise, without the prior written permission of GEFFRAN S.p.A.

Rev.	Date	Modification Description	Des/Sch	Appvd
00	29-1-2014			
1				
1				

Date:		29-1-2014	
Rev.:		00	
N.:		AFE Connection	
Name:		Loc.:	
Funct.:		Des.:	
Sch.:		Appr.:	
Digit.:		Sch.:	
Appr.:		Appr.:	

N.:		00	
Date:		29-1-2014	
Rev.:		00	
N.:		AFE Connection	
Name:		Loc.:	
Funct.:		Des.:	
Sch.:		Appr.:	
Digit.:		Sch.:	
Appr.:		Appr.:	

N.:		00	
Date:		29-1-2014	
Rev.:		00	
N.:		AFE Connection	
Name:		Loc.:	
Funct.:		Des.:	
Sch.:		Appr.:	
Digit.:		Sch.:	
Appr.:		Appr.:	

For parallel sizes:
AFE200 400kW ... 1.65MW

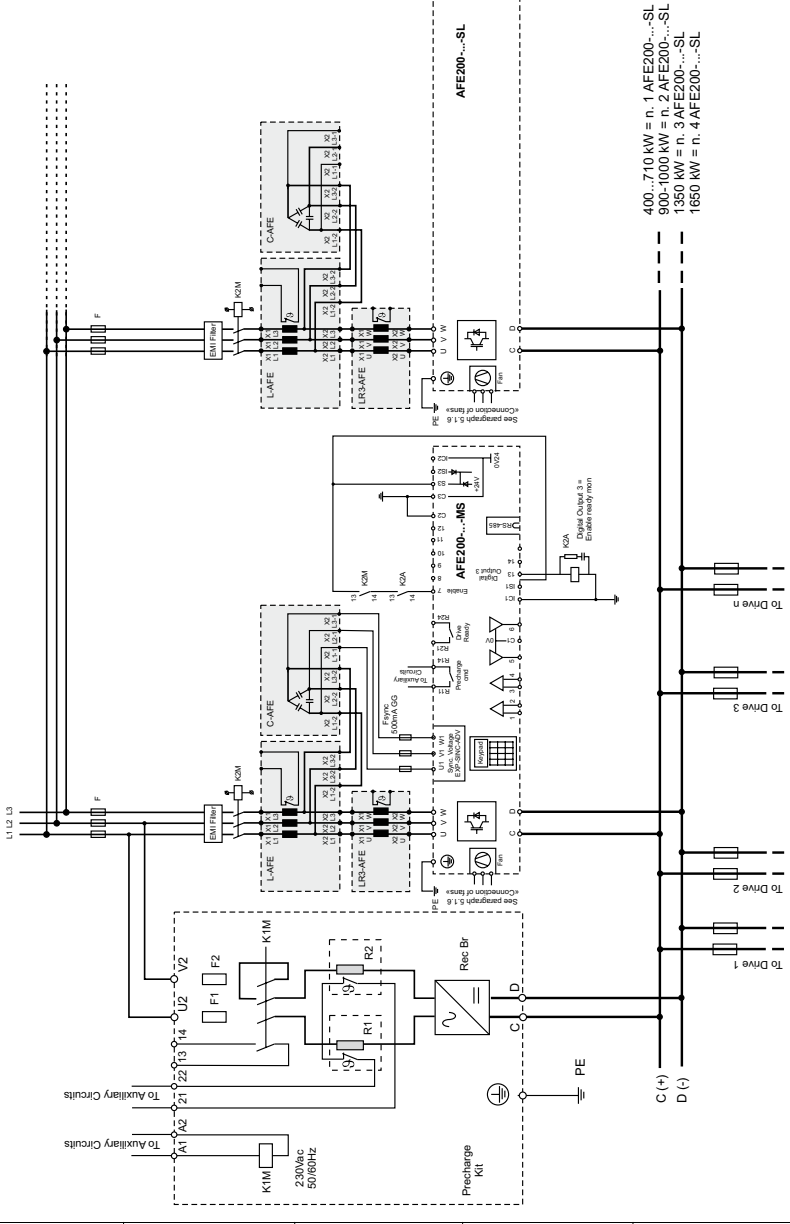

400...710 kW = n. 1 AFE200...-SL
 900-1000 kW = n. 2 AFE200...-SL
 1350 kW = n. 3 AFE200...-SL
 1650 kW = n. 4 AFE200...-SL

Rev.	Date	Modification	Description	Des/Sch	Apprvd	Name	Nr	Date	Rev.
1						AFE Parallel Connection	01	27-9-2016	01
2						Loc.			
3						Func.			
4						Des. - BR1	Sch.	Appr. - CNL	1
5									1

GEFRAN
 GEFRAN S.p.A.
 Via Salaria, 1019
 00198 Roma, Italia

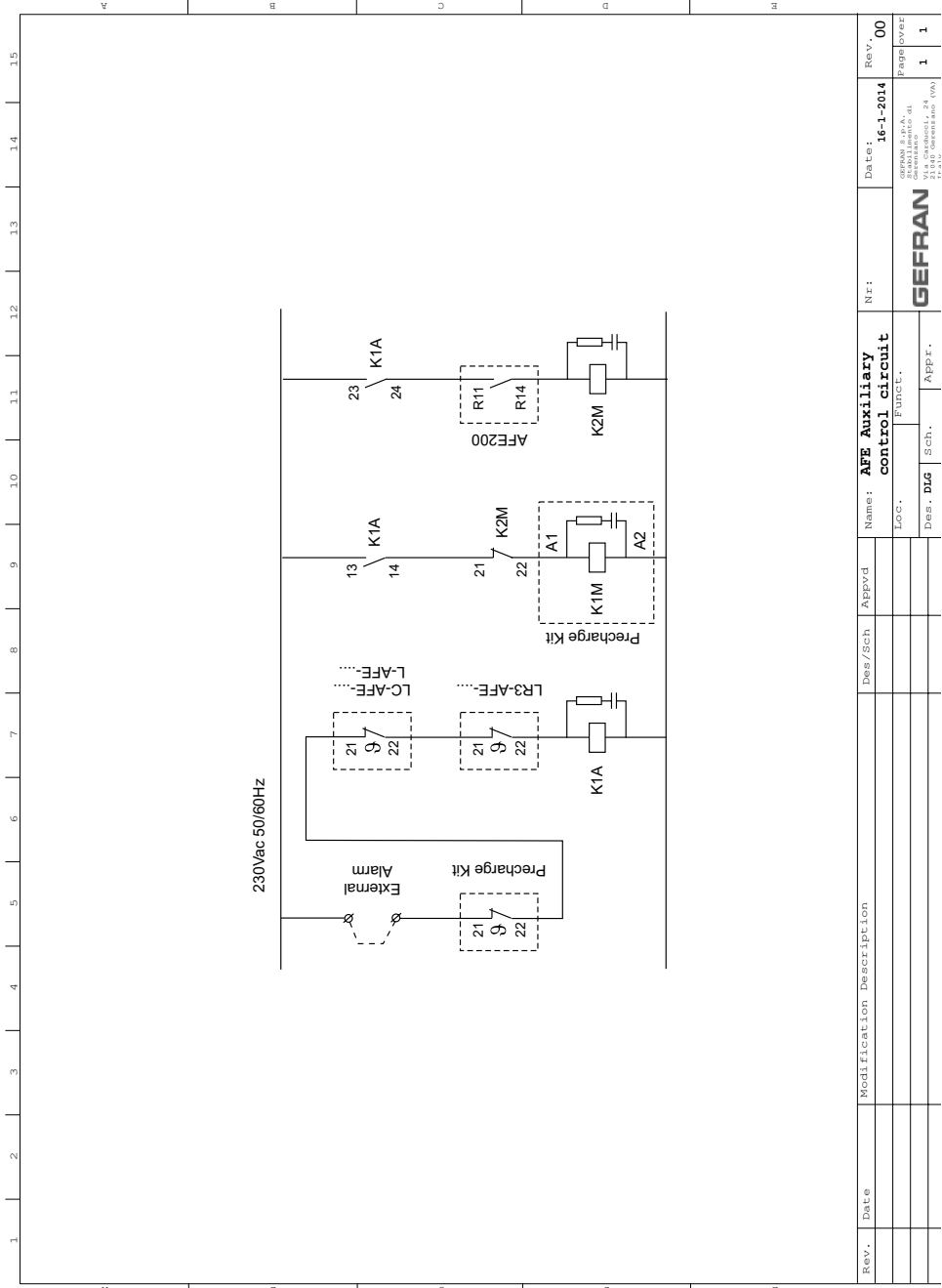

Rev.	Date	Modification	Description	Des/Sch.	Appvd	Name:	Nr:	Date:	Rev:
						AFE Auxiliary control circuit		16-1-2014	00
						LOC:			Page/over
						DES: DIG			1
						SCH:			1
						APPR:			1

GEFRAN

VIA CARROCCI, 24
41012 GROSSETO (GR)

5.5 Precharge Kit

The pre-charge kit (mandatory) is not included in the AFE200 order code and must be ordered separately. The purpose of the pre-charge circuit is to charge the voltage in the DC section with a specific charging time that depends on the DC Link capacitance value and pre-charge resistors. AFE200 units **must not** be connected to mains without pre-charging.

Parallel connection

Only the AFE200 master have its own pre-charge circuit.

AFE200-...-4	Precharge KIT 400Vac Mains			Maximum capacity DC-LINK (AFE+ Drive)	
	KIT Size	Code	Model	AC input 480V	AC input 400V
3220...4450	1	S72828	PRE-CHARGE KIT-AFE-22/45-4	15000 μ F	21500 μ F
5900...61320	1	S728281	PRE-CHARGE KIT-AFE-90/132-4	29900 μ F	43000 μ F
71600...73550	2	S728282	PRE-CHARGE KIT-AFE-160/710-4	185300 μ F	266900 μ F
400...710 kW					
900 kW...1 MW	3	S728284	PRE-CHARGE KIT-AFE-900/1650-4	370600 μ F	533800 μ F

AFE200-...-6	Precharge KIT 690Vac Mains			Maximum capacity DC-LINK (AFE+ Drive)	
	KIT Size	Code	Model	AC input 690V	
71600...73550	2	S728283	PRE-CHARGE KIT-AFE-160/710-6	89700 μ F	
400...710 kW				185300 μ F	
900 kW...1.65 MW	3	S728285	PRE-CHARGE KIT-AFE-900/1650-6	370600 μ F	

Note !

.....
 The dissipated power from Kit is only temporarily and only during the pre-charge phase; therefore, it does not generate a constant temperature increase.

5.5.1 Fuses internal to the pre-charge kit

The fuses shown are included as standard with the pre-charge kit.

Sizes AFE200-	Type	Q.ty	Code
3220 ... 61320 -4	FUSE-PWR-XC38 15A 600V	2	S829B
71600 ... 73550 -4 1 MW -4	FUSE-PWR-XC38 25A 600V	2	S823B
71600 ... 73550 -6 1 MW ...1.65 MW -6	FUSE-PWR-XC51 50A 690V	2	S85C23

5.5.2 Pre-charge kit dimensions and Cable Cross Section

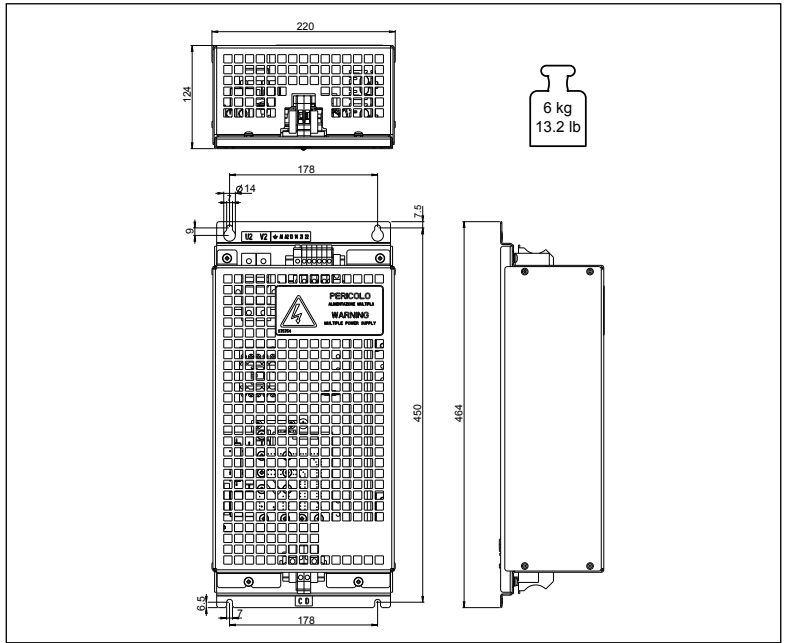

Figure 5.5.1 : Pre-charge kit size 1 (cod. S72828 and S728281)

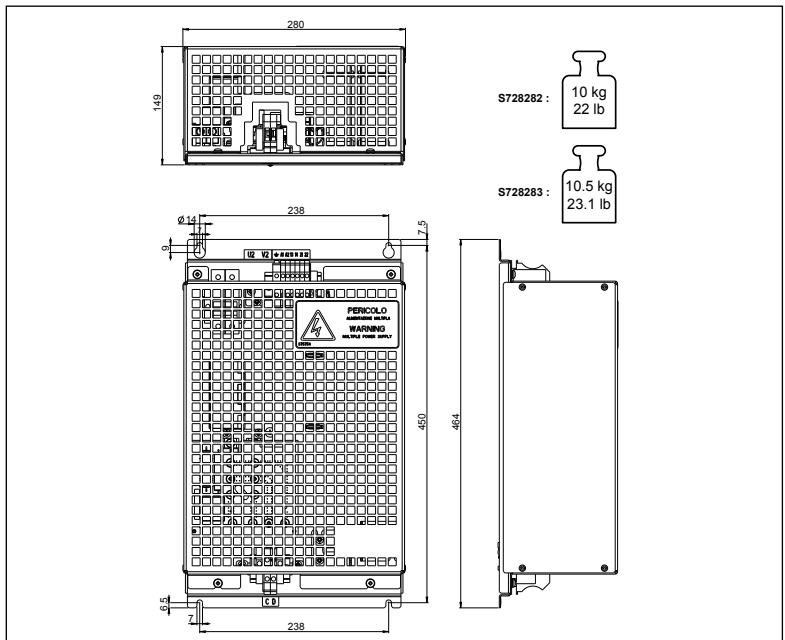

Figure 5.5.2 : Pre-charge kit size 2 (cod. S728282 and S728283)

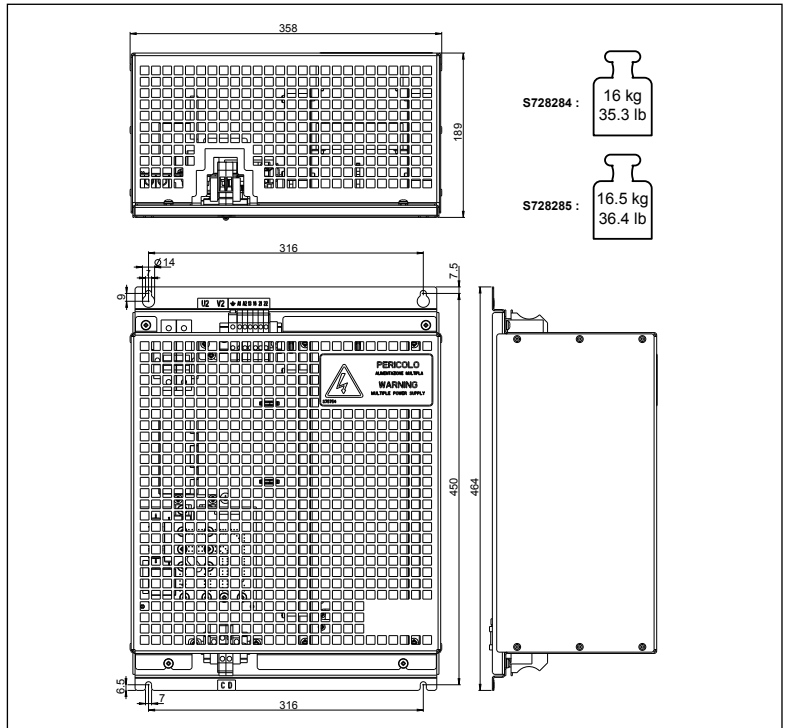
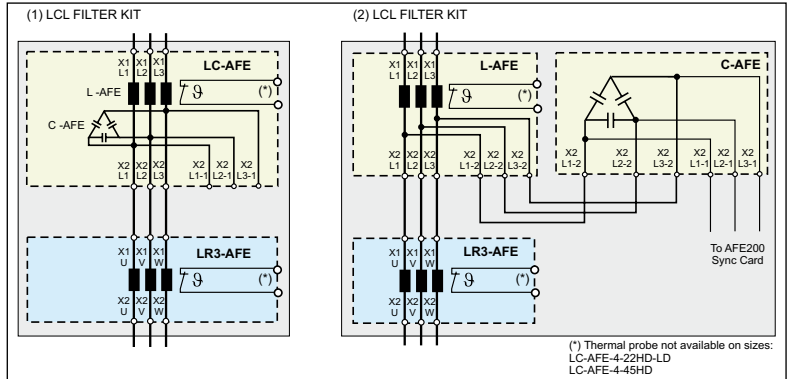

Figure 5.5.3 : Pre-charge kit size 3 (cod. S728284 and S728285)

Type	Code	Terminals: U2, V2 (AC Input)		Terminals: (DC Output)	
		Recommended Cable Cross Section	Tightening torque (min)	Recommended Cable Cross Section	Tightening torque (min)
		AWG (V)	(Nm)	AWG (V)	(Nm)
PRE-CHARGE KIT-AFE-22/45-4	S72828	AWG 10 (600V)	0.8 ... 1.6	AWG 8 (1000V)	0.8 ... 1.6
PRE-CHARGE KIT-AFE-90/132-4	S728281	AWG 10 (600V)	0.8 ... 1.6	AWG 10 (600V)	0.8 ... 1.6
PRE-CHARGE KIT-AFE-160/710-4	S728282	AWG 10 (600V)	0.8 ... 1.6	AWG 10 (600V)	0.8 ... 1.6
PRE-CHARGE KIT-AFE-900/1650-4	S728284	AWG 10 (600V)	0.8 ... 1.6	AWG 10 (600V)	0.8 ... 1.6
PRE-CHARGE KIT-AFE-160/710-6	S728283	AWG 8 (1000V)	4	AWG 8 (1000V)	4
PRE-CHARGE KIT-AFE-900/1650-6	S728285	AWG 8 (1000V)	4	AWG 8 (1000V)	4

5.6 LCL Filters



LCL filter must be connected between AFE and the AC line supply.

It reduces the harmonics related to the switching frequency of the IGBT power bridge (high order harmonics).

Decreasing the harmonic current distortion, it improves the line power quality and its voltage distortion.

The specified LCL filters refer to the default value of the AFE200 switching frequency. This frequency **must not be changed**.

(1) LCL filter for sizes (AC input 400...480Vac and 690Vac):

- From size AFE200-3220 to 71600 configuration HD (160kW ovid 150%)
- From size AFE200-3220 to 61320 configuration LD (160kW ovid 110%)

is composed by one choke connected on the AFE line input (**LR3-AFE**) and one LC device (**LC-AFE**) composed by a capacitors bank and a line choke in a single package

(2) LCL filter for sizes (AC input 400...480Vac and 690Vac):

- From size AFE200-72000 to 73550 configuration HD (355kW ovid 150%)
- From size AFE200-71600 to 73550 configuration LD (400kW ovid 110%)
- All Parallel configuration

is composed by one choke connected on the AFE line input (**LR3-AFE**), and one LC device (**LC-AFE**) composed by a capacitors package (**C-AFE**) and a line choke (**L-AFE**)

Note!

See chapter "5.1.1 Cable Cross Section" on page 25 for cable sizes.

For LCL filter sizes, see sections "5.6.1 LR3-AFE (Choke) Dimensions, Cable Cross Section and data" on page 54, "5.6.2 LC-AFE (Choke + capacitors) Dimensions, Cable Cross Section and data" on page 56, "5.6.4 C-AFE (Capacitor) Dimensions and Cable Cross Section" on page 58 and "5.6.4 L-AFE (Capacitor) Dimensions and Cable Cross Section" on page 58.

Table 5.6.1: LCL Filters / AFE200-4 matching (Heavy Duty)

LCL Filters Type	Code	AFE200-4 (kW) - Heavy Duty														
		22kW	45kW	90kW	132kW	160kW	200kW	250kW	315kW	355kW	400kW	500kW	630kW	710kW	900kW	1MW
LCL-Kit-AFE-4-22-HD	S7LC09	1														
LCL-Kit-AFE-4-45-HD	S7LC01		1													

		AFE200-4 (kW) - Heavy Duty														
LCL Filters Type	Code	22kW	45kW	90kW	132kW	160kW	200kW	250kW	315kW	355kW	400kW	500kW	630kW	710kW	900kW	11MW
LCL-Kit-AFE-4-90-HD	S7LC02			1												
LCL-Kit-AFE-4-132-HD	S7LC03				1											
LCL-Kit-AFE-4-132-LD/160-HD	S7LC04					1										
LCL-Kit-AFE-4-160-LD/200-HD	S7LC05						1				2					
LCL-Kit-AFE-4-250-HD	S7LC06							1				2				
LCL-Kit-AFE-4-250-LD/315-HD	S7LC07								1				2		3	
LCL-Kit-AFE-4-315-LD/355-HD	S7LC08									1				2		3

Table 5.6.2: LCL Filters / AFE200-4 matching (Low Duty)

		AFE200-4 (kW) - Low Duty														
LCL Filters Type	Code	22kW	45kW	90kW	132kW	160kW	200kW	250kW	315kW	355kW	400kW	500kW	630kW	710kW	900kW	11MW
LCL-Kit-AFE-4-22-LD	S7LC15	1														
LCL-Kit-AFE-4-45-LD	S7LC16		1													
LCL-Kit-AFE-4-90-LD	S7LC17			1												
LCL-Kit-AFE-4-132-LD/160-HD	S7LC04				1											
LCL-Kit-AFE-4-160-LD/200-HD	S7LC05					1										
LCL-Kit-AFE-4-200-LD	S7LC18						1				2					
LCL-Kit-AFE-4-250-LD/315-HD	S7LC07							1				2				
LCL-Kit-AFE-4-315-LD/355-HD	S7LC08								1				2		3	
LCL-Kit-AFE-4-355-LD	S7LC19									1				2		3

Table 5.6.3: LCL Filters composition (Heavy Duty)

LCL Filters Type	Code	LR3-AFE	Code	LC-AFE	Code		
LCL-Kit-AFE-4-22-HD	S7LC09	LR3-AFE-4-22-HD	S7ALC10	LC-AFE-4-22HD	S7ALC9M		
LCL-Kit-AFE-4-45-HD	S7LC01	LR3-AFE-4-45-HD	S7ALC2	LC-AFE-4-45-HD	S7ALC1M		
LCL-Kit-AFE-4-90-HD	S7LC02	LR3-AFE-4-90-HD	S7ALC8	LC-AFE-4-90-HD	S7ALC7M		
LCL-Kit-AFE-4-132-HD	S7LC03	LR3-AFE-4-132-HD	S7ALC12	LC-AFE-4-132-HD	S7ALC11M		
LCL-Kit-AFE-4-132-LD/160-HD	S7LC04	LR3-AFE-4-160-HD	S7ALC14	LC-AFE-4-160-HD	S7ALC13M		
LCL Filters Type	Code	LR3-AFE	Code	L-AFE	Code	C-AFE	Code
LCL-Kit-AFE-4-160-LD/200-HD	S7LC05	LR3-AFE-4-200-HD	S7ALC16	L-AFE-4-200-HD	S7ALC15	C-AFE-4-33	S7ALC15C
LCL-Kit-AFE-4-250-HD	S7LC06	LR3-AFE-4-250-HD	S7ALC4	L-AFE-4-250-HD	S7ALC3	C-AFE-4-47	S7ALC3C
LCL-Kit-AFE-4-250-LD/315-HD	S7LC07	LR3-AFE-4-315-HD	S7ALC18	L-AFE-4-315-HD	S7ALC17	C-AFE-4-68	S7ALC17C
LCL-Kit-AFE-4-315-LD/355-HD	S7LC08	LR3-AFE-4-355-HD	S7ALC6	L-AFE-4-355-HD	S7ALC5	C-AFE-4-68	S7ALC17C

Table 5.6.4: LCL Filters composition (Low Duty)

LCL Filters Type	Code	LR3-AFE	Code	LC-AFE	Code
LCL-Kit-AFE-4-22-LD	S7LC15	LR3-AFE-4-22-LD	S7ALC40	LC-AFE-4-22-LD	S7ALC41M
LCL-Kit-AFE-4-45-LD	S7LC16	LR3-AFE-4-55-HD	S7ALC42	LC-AFE-4-55-HD	S7ALC43M
LCL-Kit-AFE-4-90-LD	S7LC17	LR3-AFE-4-110-HD	S7ALC44	LC-AFE-4-110-HD	S7ALC45M
LCL-Kit-AFE-4-132-LD/160-HD	S7LC04	LR3-AFE-4-160-HD	S7ALC14	LC-AFE-4-160-HD	S7ALC13M

LCL Filters Type	Code	LR3-AFE	Code	L-AFE	Code	C-AFE	Code
LCL-Kit-AFE-4-160-LD/200-HD	S7LC05	LR3-AFE-4-200-HD	S7ALC16	L-AFE-4-200-HD	S7ALC15	C-AFE-4-33	S7ALC15C
LCL-Kit-AFE-4-200-LD	S7LC18	LR3-AFE-4-200-LD	S7ALC46	L-AFE-4-200-LD	S7ALC47	C-AFE-4-47	S7ALC3C
LCL-Kit-AFE-4-250-LD/315-HD	S7LC07	LR3-AFE-4-315-HD	S7ALC18	L-AFE-4-315-HD	S7ALC17	C-AFE-4-68	S7ALC17C
LCL-Kit-AFE-4-315-LD/355-HD	S7LC08	LR3-AFE-4-355-HD	S7ALC6	L-AFE-4-355-HD	S7ALC5	C-AFE-4-68	S7ALC17C
LCL-Kit-AFE-4-355-LD	S7LC19	LR3-AFE-4-355-LD	S7ALC48	L-AFE-4-355-LD	S7ALC49	C-AFE-4-68	S7ALC17C

Table 5.6.5: LCL Filters / AFE200-6 matching (Heavy Duty)

LCL Filters Type	Code	AFE200-6 (kW) - Heavy Duty												
		160kW	200kW	250kW	315kW	355kW	400kW	500kW	630kW	710kW	900kW	1100W	1.35MW	1.65MW
LCL-Kit-AFE-6-160-HD	S7LC10	1												
LCL-Kit-AFE-6-200-HD	S7LC11		1				2							
LCL-Kit-AFE-6-200-LD/250-HD	S7LC12			1				2						
LCL-Kit-AFE-6-250-LD/315-HD	S7LC13				1				2		3			
LCL-Kit-AFE-6-315-LD/355-HD	S7LC14					1				2		3	4	5

Table 5.6.6: LCL Filters / AFE200-6 matching (Low Duty)

LCL Filters Type	Code	AFE200-6 (kW) - Low Duty												
		160kW	200kW	250kW	315kW	355kW	400kW	500kW	630kW	710kW	900kW	1100W	1.35MW	1.65MW
LCL-Kit-AFE-6-160-LD	S7LC20	1												
LCL-Kit-AFE-6-200-LD/250-HD	S7LC12		1				2							
LCL-Kit-AFE-6-250-LD/315-HD	S7LC13			1				2						
LCL-Kit-AFE-6-315-LD/355-HD	S7LC14				1				2		3			
LCL-Kit-AFE-6-355-LD	S7LC21					1				2		3	4	5

Table 5.6.7: LCL Filters composition (Heavy Duty)

LCL Filters Type	Code	LR3-AFE	Code	LC-AFE	Code		
LCL-Kit-AFE-6-160-HD	S7LC10	LR3-AFE-6-160-HD	S7ALC20	LC-AFE-6-160-HD	S7ALC21M		
LCL Filters Type	Code	LR3-AFE	Code	L-AFE	Code	C-AFE	Code
LCL-Kit-AFE-6-200-HD	S7LC11	LR3-AFE-6-200-HD	S7ALC22	L-AFE-6-200-HD	S7ALC23	C-AFE-6-22	S7ALC23C
LCL-Kit-AFE-6-200-LD/250-HD	S7LC12	LR3-AFE-6-250-HD	S7ALC24	L-AFE-6-250-HD	S7ALC25	C-AFE-6-33	S7ALC25C
LCL-Kit-AFE-6-250-LD/315-HD	S7LC13	LR3-AFE-6-315-HD	S7ALC26	L-AFE-6-315-HD	S7ALC27	C-AFE-6-33	S7ALC25C
LCL-Kit-AFE-6-315-LD/355-HD	S7LC14	LR3-AFE-6-355-HD	S7ALC28	L-AFE-6-355-HD	S7ALC29	C-AFE-6-47	S7ALC29C

Table 5.6.8: LCL Filters composition (Low Duty)

LCL Filters Type	Code	LR3-AFE	Code	L-AFE	Code	C-AFE	Code
LCL-Kit-AFE-6-160-LD	S7LC20	LR3-AFE-6-160-LD	S7ALC50	L-AFE-6-160-LD	S7ALC51	C-AFE-6-22	S7ALC23C
LCL-Kit-AFE-6-200-LD/250-HD	S7LC12	LR3-AFE-6-250-HD	S7ALC24	L-AFE-6-250-HD	S7ALC25	C-AFE-6-33	S7ALC25C
LCL-Kit-AFE-6-250-LD/315-HD	S7LC13	LR3-AFE-6-315-HD	S7ALC26	L-AFE-6-315-HD	S7ALC27	C-AFE-6-33	S7ALC25C
LCL-Kit-AFE-6-315-LD/355-HD	S7LC14	LR3-AFE-6-355-HD	S7ALC28	L-AFE-6-355-HD	S7ALC29	C-AFE-6-47	S7ALC29C
LCL-Kit-AFE-6-355-LD	S7LC21	LR3-AFE-6-355-LD	S7ALC52	L-AFE-6-355-LD	S7ALC53	C-AFE-6-47	S7ALC29C

5.6.1 LR3-AFE (Choke) Dimensions, Cable Cross Section and data

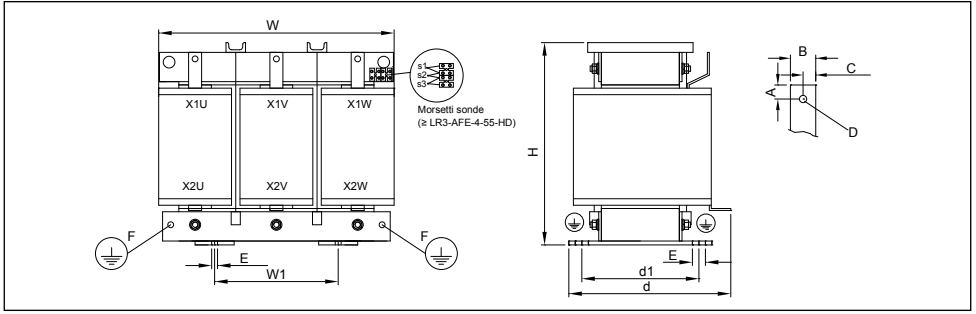

Type	Code	Dimensions (mm)											Weight (kg) ~	
		W	H	d	W1	d1	E	F	Bars					
									Type	A	B	C		D
LR3-AFE-4-22-HD	S7ALC10	9x20	225	185	260	125	9x15	Ø7	AL20 x 3	10	20	10	1 x Ø7	28
LR3-AFE-4-22-LD	S7ALC40	370	255	250±5	200	150	9x15	Ø7	AL20 x 3	10	20	10	1 x Ø7	48
LR3-AFE-4-45-HD	S7ALC2	370	255	250±5	200	150	9x15	Ø7	AL20 x 3	10	20	10	1 x Ø7	48
LR3-AFE-4-55-HD	S7ALC42	370	285	250±5	200	175	9x15	Ø7	AL30 x 3	15	30	15	1 x Ø11	55
LR3-AFE-4-90-HD	S7ALC8	370	315	250±5	190	180	9x15	Ø9	AL20 x 3	10	20	10	1 x Ø10	75
LR3-AFE-4-110-HD	S7ALC44	370	355	270±5	190	180	9x15	Ø9	AL30 x 3	15	30	15	1 x Ø11	80
LR3-AFE-4-132-HD	S7ALC12	370	410	275±5	200	175	9x15	Ø9	AL30 x 4	15	30	15	1 x Ø11	90
LR3-AFE-4-160-HD	S7ALC14	430	475	335	250	225	11X20	Ø9	AL30 x 5	15	30	15	1 x Ø11	125
LR3-AFE-4-200-HD	S7ALC16	430	480	340	250	225	11X20	Ø9	AL40 x 5	20	40	20	1 x Ø11	130
LR3-AFE-4-200-LD	S7ALC46	490	490	375±5	250	250	11X20	Ø9	AL40 x 5	20	40	20	1 x Ø11	210
LR3-AFE-4-250-HD	S7ALC4	480	480	350	400	225	11X20	Ø9	AL45 x 5	20	40	20	1 x Ø11	150
LR3-AFE-4-315-HD	S7ALC18	490	560	410±5	300	275	11X20	Ø9	AL50 x 8	25	50	25	1 x Ø11	240
LR3-AFE-4-355-HD	S7ALC6	490	560	425±5	250	275	11X20	Ø9	AL50 x 8	25	50	25	1 x Ø11	240
LR3-AFE-4-355-LD	S7ALC48	510	560	430±5	300	275	11X20	Ø9	AL50 x 8	25	50	25	1 x Ø11	260
LR3-AFE-6-160-HD	S7ALC20	370	410	275±5	200	175	11X20	Ø9	AL30 x 3	15	30	15	1 x Ø11	90
LR3-AFE-6-160-LD	S7ALC50	430	475	335	200	225	11X20	Ø9	AL30 x 3	15	30	15	1 x Ø11	125
LR3-AFE-6-200-HD	S7ALC22	415	455	360	275	225	11X20	Ø7	AL30 x 3	15	30	15	1 x Ø11	150
LR3-AFE-6-250-HD	S7ALC24	490	490	380±5	250	250	11X20	Ø9	AL30 x 5	15	30	15	1 x Ø11	210
LR3-AFE-6-315-HD	S7ALC26	490	560	370±5	250	250	11X20	Ø9	AL40 x 5	20	40	20	1 x Ø11	240
LR3-AFE-6-355-HD	S7ALC28	490	560	415±5	250	275	11X20	Ø9	AL40 x 5	20	40	20	1 x Ø11	240
LR3-AFE-6-355-LD	S7ALC52	510	560	415±5	300	275	11X20	Ø9	AL40 x 5	20	40	20	1 x Ø11	250

Type	Code	Bars: X1 U, X1 V, X1 W; X2 U, X2 V, X2 W			⏚ on mechanical cabinet		
		Recommended Cable Cross Section (mm²) / AWG	Lock screw diameter	Tightening torque (min) (Nm)	Maximum Cable Cross Section (mm²) / AWG	Recommended terminal	Hole diameter (mm)
LR3-AFE-4-22-HD	S7ALC10	16 / 6	M6	6	16 / 6	Eyelet - Spade	Ø 7
LR3-AFE-4-22-LD	S7ALC40	16 / 6	M6	6			
LR3-AFE-4-45-HD	S7ALC2	35 / 2	M6	6			
LR3-AFE-4-55-HD	S7ALC42	35 / 2	M10	25	50 / 1/0	Eyelet - Spade	Ø 9
LR3-AFE-4-90-HD	S7ALC8	95 / 4/0	M8	12			
LR3-AFE-4-110-HD	S7ALC44	95 / 4/0	M10	25	120 / 250 kcmil	Eyelet - Spade	Ø 9
LR3-AFE-4-132-HD	S7ALC12	240 / 500	M10	25			

Type	Code	Bars: X1 U, X1 V, X1 W; X2 U, X2 V, X2 W			⏏ on mechanical cabinet		
		Recommended Cable Cross Section (mm ²) / AWG/kcmil	Lock screw diameter	Tightening torque (min) (Nm)	Cable Cross Section (mm ²) / AWG/kcmil	Recommended terminal	Hole diameter (mm)
LR3-AFE-4-160-HD	S7ALC14	2 x 100 / 2xAWG 4/0	M10	25	150 / 300 kcmil	Eyelet	Ø 9
LR3-AFE-4-200-HD	S7ALC16	2 x 100 / 2xAWG 4/0	M10	25	150 / 300 kcmil	Eyelet	Ø 9
LR3-AFE-4-200-LD	S7ALC46	2 x 100 / 2xAWG 4/0	M10	25	150 / 300 kcmil	Eyelet	Ø 9
LR3-AFE-4-250-HD	S7ALC4	2 x 150 / 2x300 kcmil	M10	25	150 / 300 kcmil	Eyelet	Ø 9
LR3-AFE-4-315-HD	S7ALC18	2 x 185 / 2x350 kcmil	M10	25	185 / 350 kcmil	Eyelet	Ø 9
LR3-AFE-4-355-HD	S7ALC6	2 x 185 / 2x350 kcmil	M10	25	185 / 350 kcmil	Eyelet	Ø 9
LR3-AFE-4-355-LD	S7ALC48	2 x 185 / 2x350 kcmil	M10	25	185 / 350 kcmil	Eyelet	Ø 9
LR3-AFE-6-160-HD	S7ALC20	95 / AWG 4/0	M10	25	50 / AWG 1/0	Eyelet	Ø 9
LR3-AFE-6-160-LD	S7ALC50						
LR3-AFE-6-200-HD	S7ALC22	150 / 300 kcmil	M10	25	75 / AWG 2/0	Eyelet	Ø 9
LR3-AFE-6-250-HD	S7ALC24	240 / 500 kcmil	M10	25	120 / 250 kcmil	Eyelet	Ø 9
LR3-AFE-6-315-HD	S7ALC26	2 x 100 / 2xAWG 4/0	M10	25	150 / 300 kcmil	Eyelet	Ø 9
LR3-AFE-6-355-HD	S7ALC28						
LR3-AFE-6-355-LD	S7ALC52						

Type	Terminals: thermal probe	
	Maximum Cable Cross Section	Recommended stripping
	(mm ² / AWG)	(mm)
≥ LR3-AFE-4-55-HD	1.3 / 16	7

Type	Code	Choke -5%/+ 10% (μH)	Dissipated power @ 50Hz (W)	Dissipated power @ 60Hz (W)
LR3-AFE-4-22-HD	S7ALC10	1105	429	523
LR3-AFE-4-22-LD	S7ALC40	1470	641	797
LR3-AFE-4-45-HD	S7ALC2	550	410	721
LR3-AFE-4-55-HD	S7ALC42	880	652	750
LR3-AFE-4-90-HD	S7ALC8	550	799	887
LR3-AFE-4-110-HD	S7ALC44	440	965	1061
LR3-AFE-4-132-HD	S7ALC12	385	1135	1245
LR3-AFE-4-160-HD	S7ALC14	315	1317	1465
LR3-AFE-4-200-HD	S7ALC16	260	1455	1602
LR3-AFE-4-200-LD	S7ALC46	440	1903	2154
LR3-AFE-4-250-HD	S7ALC4	220	1637	1791
LR3-AFE-4-315-HD	S7ALC18	355	2441	2716
LR3-AFE-4-355-HD	S7ALC6	315	2738	3012
LR3-AFE-4-355-LD	S7ALC48	295	2717	3008
LR3-AFE-6-160-HD	S7ALC20	845	960	1065
LR3-AFE-6-160-LD	S7ALC50	665	1162	1336
LR3-AFE-6-200-HD	S7ALC22	1350	1827	2022
LR3-AFE-6-250-HD	S7ALC24	1050	1969	2232
LR3-AFE-6-315-HD	S7ALC26	850	2151	2457
LR3-AFE-6-355-HD	S7ALC28	750	2747	3051
LR3-AFE-6-355-LD	S7ALC52	665	2351	2619

5.6.2 LC-AFE (Choke + capacitors) Dimensions, Cable Cross Section and data

LC-AFE-4-22-HD ... LC-AFE-4-45-HD

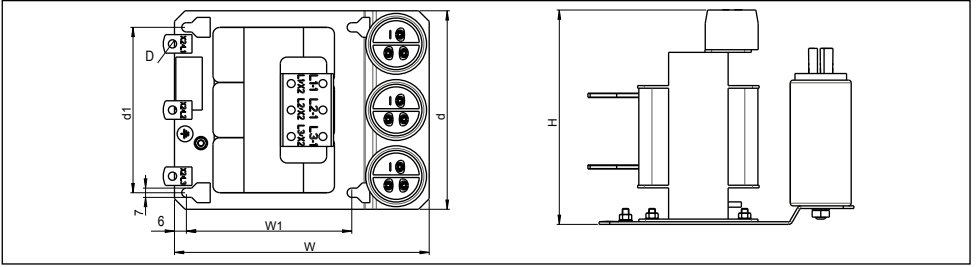

LC-AFE-4-55-HD ... LC-AFE-6-160-HD

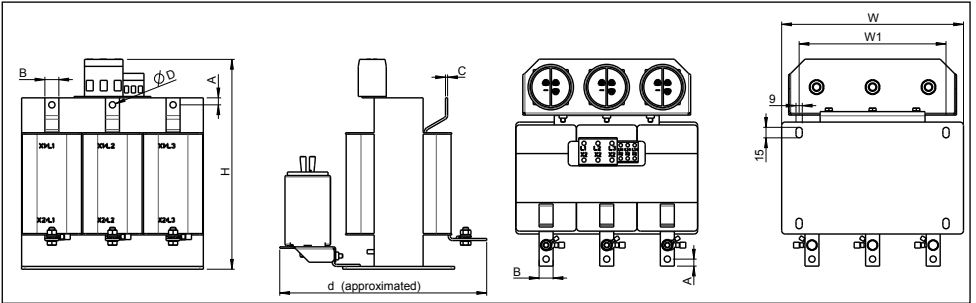

Type	Code	Dissipated power		Dimensions (mm)								Weight (kg) ~	
		50 Hz	60 Hz	W	H	d	W1	d1	Bars				
		(W)	(W)						A	B	C		D
LC-AFE-4-22-HD	S7ALC9M	24	26	192.5	182	150	125	125	-	-	-	1 x Ø6	10
LC-AFE-4-22-LD	S7ALC41M	106	118	192.5	232	245	125	125	-	-	-	1 x Ø6	18
LC-AFE-4-45-HD	S7ALC1M	44	49	192.5	220	150	125	125	-	-	-	1 x Ø6	12
LC-AFE-4-55-HD	S7ALC43M	178	197	260	245	294	200	125	15	30	3	1 x Ø11	27
LC-AFE-4-90-HD	S7ALC7M	239	263	260	300	286	210	130	10	20	3	1 x Ø9	31
LC-AFE-4-110-HD	S7ALC45M	222	246	260	300	306	200	125	15	30	3	1 x Ø11	35
LC-AFE-4-132-HD	S7ALC11M	404	436	310	335	341	250	150	15	30	4	1 x Ø11	40
LC-AFE-4-160-HD	S7ALC13M	405	433	310	335	341	250	150	15	30	5	1 x Ø11	40
LC-AFE-6-160-HD	S7ALC21M	366	446	260	270	305	200	125	15	30	5	1 x Ø11	29

Type	Code	Choke -5%/+10% (µH)	Terminals: X1 L1, X1 L2, X1 L3; X2 L1, X2 L2, X2 L3				Terminals: X2 L1-1, X2 L2-1, X2 L3-1		
			Recommended Cable Cross Section		Lock screw diameter	Tightening torque (min) (Nm)	Maximum Cable Cross Section	Recommended stripping	Tightening torque (min) (Nm)
			(mm ²) / AWG/kcmil						
LC-AFE-4-22-HD	S7ALC9M	140			M6	6	1.3 / 16	12	0.7
LC-AFE-4-22-LD	S7ALC41M	470	16 / 6						
LC-AFE-4-45-HD	S7ALC1M	65			M6	6	1.3 / 16	12	0.7
LC-AFE-4-55-HD	S7ALC43M	315	35 / 2						
LC-AFE-4-90-HD	S7ALC7M	205			M8	13	1.3 / 16	12	0.7
LC-AFE-4-110-HD	S7ALC45M	145	95 / 4/0						
LC-AFE-4-132-HD	S7ALC11M	145	240 / 500		M10	25	1.3 / 16	12	0.7
LC-AFE-4-160-HD	S7ALC13M	95	2 x 100 / 2xAWG 4/0						
LC-AFE-6-160-HD	S7ALC21M	185	95 / AWG 4/0		M10	25	1.3 / 16	12	0.7

5.6.3 L-AFE (Choke) Dimensions, Cable Cross Section and data

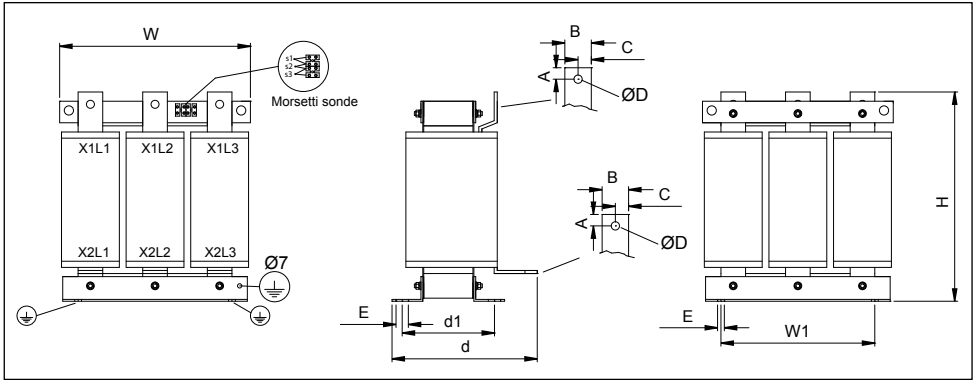

Type	Code	Dimensions (mm)												Weight (kg) ~
		W	H	d	W1	d1	E	F	Bars					
									Type	A	B	C	D	
L-AFE-4-200-HD	S7ALC15	310	340	240 ±5	250	150	11x20	Ø 7	AL40x5	20	40	20	Ø 11	42
L-AFE-4-200-LD	S7ALC47	245	415	355 ±5	250	225	11x20	Ø 9	AL40x5	20	40	20	Ø 11	145
L-AFE-4-250-HD	S7ALC3	310	345	235 ±5	250	150	11x20	Ø 9	AL40x5	20	40	20	Ø 11	45
L-AFE-4-315-HD	S7ALC17	415	450	355 ±5	300	225	11x20	Ø 9	AL50x8	25	50	25	Ø 11	145
L-AFE-4-355-HD	S7ALC5	415	450	375 ±5	325	225	11x20	Ø 9	AL50x8	25	50	25	Ø 11	155
L-AFE-4-355-LD	S7ALC49	415	520	350 ±5	300	225	11x20	Ø 9	AL50x8	25	50	25	Ø 11	180
L-AFE-6-160-LD	S7ALC51	260	225	230	200	125	9x15	Ø 9	AL30x3	15	30	15	Ø 11	24
L-AFE-6-200-HD	S7ALC23	370	325	280 ±5	275	200	11x20	Ø 9	AL30x3	15	30	15	Ø 11	75
L-AFE-6-250-HD	S7ALC25	370	250	300 ±5	250	180	11x20	Ø 9	AL30x5	15	30	15	Ø 11	75
L-AFE-6-315-HD	S7ALC27	415	355	335 ±5	300	225	11x20	Ø 9	AL40x5	20	40	20	Ø 11	120
L-AFE-6-355-HD	S7ALC29	415	360	325 ±5	300	225	11x20	Ø 9	AL40x5	20	40	20	Ø 11	100
L-AFE-6-355-LD	S7ALC53	415	365	345 ±5	300	225	11x20	Ø 9	AL40x5	20	40	20	Ø 11	120

Type	Code	Choke -5%/+10% (µH)	Dissipated power		Bars: X1 L1, X1 L2, X1 L3; X2 L1, X2 L2, X2 L3			Terminals: thermal probe	
			@50Hz (W)	@60Hz (W)	Recommended Cable Cross Section (mm²) / AWG	Lock screw di- ameter	Tightening torque (min) (Nm)	Maximum Cable Cross Section (mm² / AWG)	Recommended stripping (mm)
L-AFE-4-200-HD	S7ALC15	95	531	565	2 x 100 / 2xAWG 4/0	M10	25	1.3 / 16	7
L-AFE-4-200-LD	S7ALC47	270	1119	1250	2 x 100 / 2xAWG 4/0	M10	25		
L-AFE-4-250-HD	S7ALC3	70	1334	1467	2 x 150 / 2x300 kcmil	M10	25		
L-AFE-4-315-HD	S7ALC17	185	1582	1990	2 x 185 / 2x350 kcmil	M10	25		
L-AFE-4-355-HD	S7ALC5	185	2180	2586	2 x 185 / 2x350 kcmil	M10	25		
L-AFE-4-355-LD	S7ALC49	185	1575	1726	2 x 185 / 2x350 kcmil	M10	25		
L-AFE-6-160-LD	S7ALC51	125	197	249	95 / AWG 4/0	M10	25	1.3 / 16	7
L-AFE-6-200-HD	S7ALC23	520	776	884	150 / 300 kcmil	M10	25		
L-AFE-6-250-HD	S7ALC25	345	799	914	150 / 300 kcmil	M10	25		
L-AFE-6-315-HD	S7ALC27	345	1159	1359	2 x 100 / 2xAWG 4/0	M10	25		
L-AFE-6-355-HD	S7ALC29	240	1289	1492	2 x 100 / 2xAWG 4/0	M10	25		
L-AFE-6-355-LD	S7ALC53	240	980	1245	2 x 100 / 2xAWG 4/0	M10	25		

5.6.4 C-AFE (Capacitor) Dimensions and Cable Cross Section

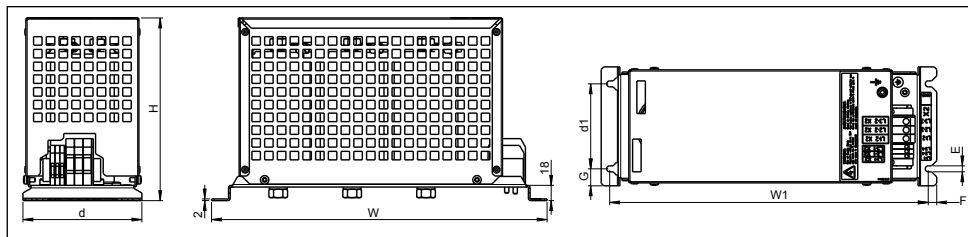

Type	Code	Dimensions (mm)								Weight (kg) ~
		W	H	d	W1	d1	E	F	G	
C-AFE-4-33	S7ALC15C	395	215	140	375	100	7	10	20	5
C-AFE-4-47	S7ALC3C	395	315	140	375	100	7	10	20	6
C-AFE-4-68	S7ALC17C	395	315	140	375	100	7	10	20	6
C-AFE-6-22	S7ALC23C	395	315	140	375	100	7	10	20	6
C-AFE-6-33	S7ALC25C	395	315	140	375	100	7	10	20	6
C-AFE-6-47	S7ALC29C	395	315	140	375	100	7	10	20	6

Type	Code	Terminals: X2 L1-2, X2 L2-2, X2 L3-2			Terminals: X2 L1-1, X2 L2-1, X2 L3-1		
		Maximum Cable Cross Section	Recommended stripping	Tightening torque	Maximum Cable Cross Section	Recommended stripping	Tightening torque
		(mm ² / AWG)	(mm)	(Nm)	(mm ² / AWG)	(mm)	(Nm)
C-AFE-4-33	S7ALC15C	8	12	1.1	1.3 / 16	12	0.7
C-AFE-4-47	S7ALC3C	8	12	1.1			
C-AFE-4-68	S7ALC17C	6	15	2.5			
C-AFE-6-22	S7ALC23C	10	12	1.1	1.3 / 16	12	0.7
C-AFE-6-33	S7ALC25C	8	12	1.1			
C-AFE-6-47	S7ALC29C	6	15	1.1			

Wire terminal bar

C-AFE is supplied with 3 connectors for bars (cable clamps). These terminals must be used for the connection between terminals "L1 X2-2, X2-2 and X2 L2 L3-2" and the bars of the L-AFE choke.

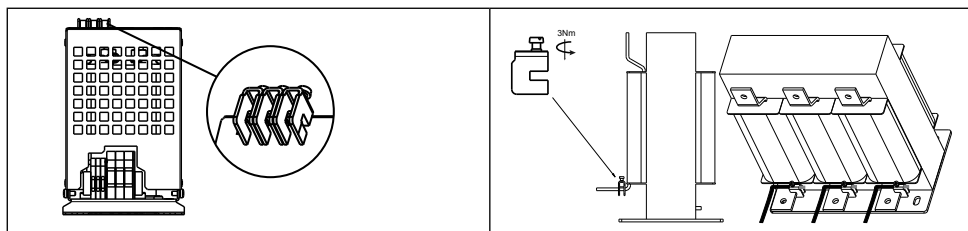

6 - Use of the keypad

This chapter describes the keypad and methods of use for display and programming of AFE200 parameters.

6.1 Description

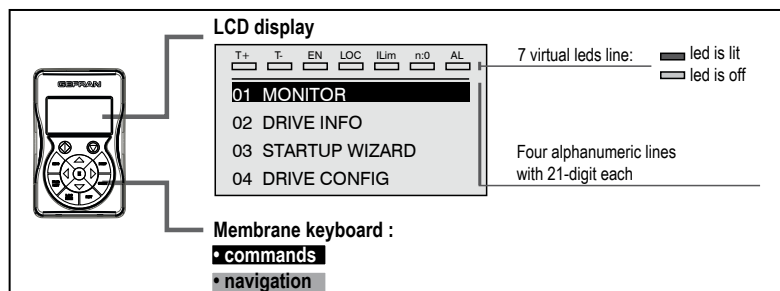

Membrane keyboard

AFE200 control programming menu navigation keys.

Symbol	Reference	Description
	Start	Activates the AFE
	Stop	Quick stop and generation of the Emg stop alarm [21] if programmed in the Stop key mode parameter, PAR 1008
ESC	Escape	Returns to the higher level menu or submenu. Exit from a parameter, a list of parameters, from the list of the last 10 parameters and from the Goto parameter function (see CUST). Can be used to exit from a message that requires use of this.
FWD REV	Forward/Reverse	Not used
LOC REM	Local/Remote	Changes the method of use from local to remote and vice versa. Is active only if the AFE is not enabled.
RST	Reset	Resets alarms only if the causes have been eliminated.
CUST	Custom	The first time it is pressed, displays the list of the last 10 parameters modified. Pressing this key a second time activates the Goto parameter function for access to a parameter through its number. To exit these functions, press the ◀ key.
DISP	Display	Displays a list of AFE functioning parameters.
E	Enter	Accesses the submenu or parameter selected or selects an operation, Is used during parameter modification to confirm the new value set.
▲	Up	Moves selection in a menu or a list of parameters up. During modification of a parameter, increases the value of the digit under the cursor.
▼	Down	Moves the selection in a menu or a list of parameters down. During modification of a parameter, decreases the value of the digit under the cursor.
◀	Left	Returns to the higher level menu. During modification of a parameter, moves the cursor to the left.
▶	Right	Accesses the submenu or parameter selected. During modification of a parameter, moves the cursor to the right.

LED's meaning:

- T+** the LED is lit, when the AFE operates with a positive torque
- T-** the LED is lit, when the AFE operates with a negative torque
- EN** the LED is lit, when the AFE is enabled
- LOC** The led is lit when the AFE is in local mode and OFF when in remote mode.
- Ilim** the LED is lit, when the AFE operates at a current limit. During normal functioning, this led is OFF.
- n=0** The LED stays on.
- AL** the LED is lit; it signals a trip.

6.2 Navigation

6.2.1 Scanning of the first and second level menus

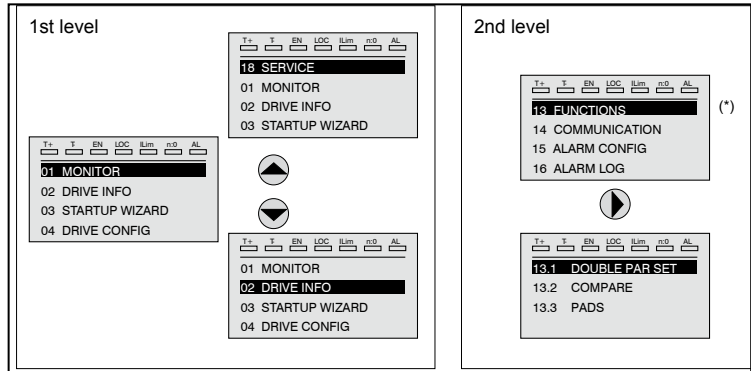

(*) This example is visible only in **Export mode** (see [paragraph 6.5.2](#)).

6.2.2 Display of a parameter

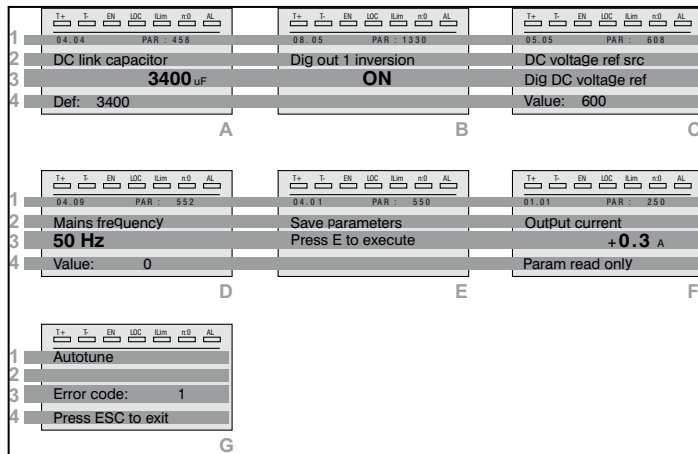

- 1 Position of the parameter in the menu structure (in figure A, 16.01); number of the parameter (in figure A, PAR: 458).
- 2 Description of the parameter.

- 3 Depends on the type of parameter:
 - **Numeric parameter:** displays the numeric value of the parameter, in the format required, and unit of measurement (figure A).
 - **Binary selection:** the parameter may assume only 2 states, indicated as OFF-ON or 0 - 1 (figure B).
 - **LINK type parameter:** displays the description of the parameter set from the selection list (figure C).
 - **ENUM type parameter:** displays the description of the selection (figure D)
 - **Command:** displays the method of execution of the command (figure E)
- 4 In this position, the following may be displayed:
 - **Numeric parameter:** displays the default, minimum and maximum values of the parameter. These values are displayed in sequence pressing the ► key (figure A).
 - **LINK type parameter:** displays the number (PAR) of the parameter set (figure C) .
 - **ENUM type parameter:** displays the numeric value corresponding to the current selection (figure D).
 - **Command:** in the case of an error in the command, indicates that ESC must be pressed to terminate the command (figure G).
 - **Messages and error conditions (figure F):**

Param read only	attempt to modify a read-only parameter
Password active	the parameter protection password is active
Drive enabled	attempt to modify a non-modifiable parameter with the AFE enabled
Input value too high	the value entered too high
Input value too low	the value entered too low
Out of range	attempt to insert a value outside the min. and max. limits

6.2.3 Scanning of the parameters

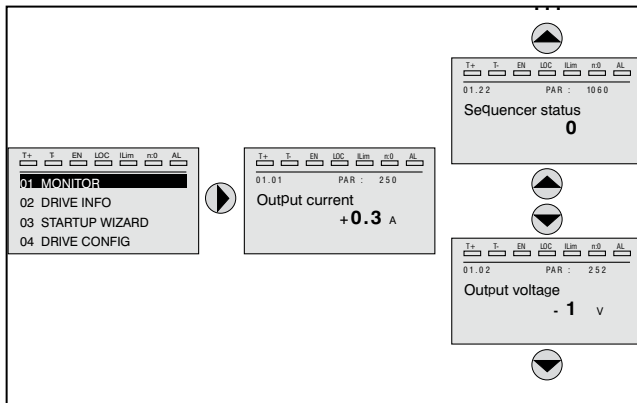

6.2.4 List of the last parameters modified

Pressing the **CUST** key, a list containing the last 10 parameters modified is accessed. One parameter at a time is displayed and the list can be scrolled using the ▲ and ▼ keys.

To exit this list, press the ► key.

6.2.5 “Goto parameter” function

Pressing the **CUST** key twice, or once if already in the “List of modified parameters”, the “Goto parameter” is activated.

This function permits access to any parameter entering only the software number

of the parameter (PAR).

When the parameter reached by the “Goto” command is displayed, it is possible to navigate all the parameters forming part of the same group using the ▲ and ▼ keys.

Pressing the ► key returns to the “Goto” function.

To exit the “Goto” function, press the ► key.

6.3 Parameter modification

To enter parameter modification mode, press the **E** key when the parameter to be modified is displayed.

To save the value of the parameter, following modification, press the **E** key again.

Note !

To save permanently, see [paragraph 6.4](#).

To exit from modification mode without saving the value, press the **ESC** key.

The operations to be carried out to modify the value depend on the type of the parameter, as described below.

Note !

For further information about the type of parameters displayed, see [chapter 8](#).

• Numeric parameters

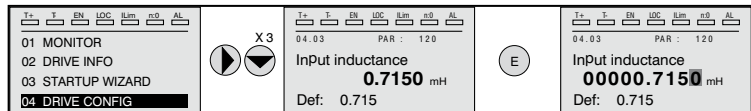

When **E** is pressed to access modification mode, the cursor is activated on the digit corresponding to the unit.

Using the ◀ and ▶ keys, the cursor can be moved to all the digits, including trailing zeros that are normally not displayed.

With the ▲ and ▼ keys, the digit under the cursor is increased or decreased.

Press **E** to confirm the modification or **ESC** to cancel.

• Binary parameters (BIT type)

The parameter may assume only two states which are indicated as OFF-ON or 0-1.

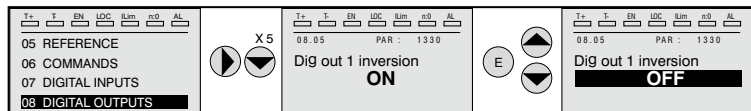

Pressing **E**, modification mode is activated. The entire line is displayed in reverse.

Use the ▲ and ▼ keys to move from one state to another.

Press **E** to confirm the modification or **ESC** to cancel.

• LINK type parameter

The parameter may assume the number of another parameter as value.

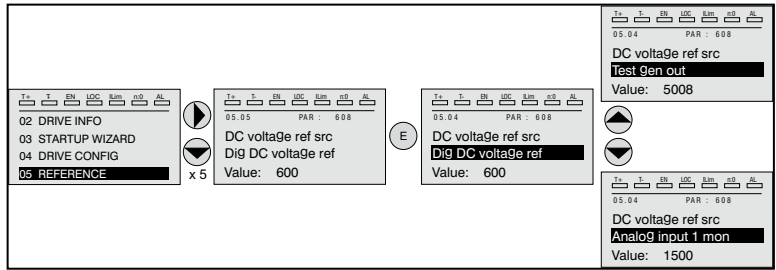

Pressing **E**, modification mode is activated. The entire line is displayed in reverse. The elements of the list of parameters associated to this parameter can be scrolled using the **▲** and **▼** keys. Press **E** to confirm the modification or **ESC** to cancel.

• **ENUM type parameter**

The parameter may assume only the values contained in a selection list.

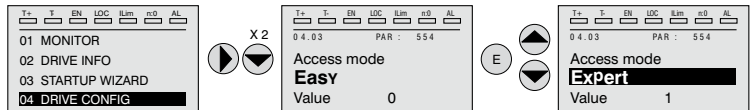

Pressing **E**, modification mode is activated. The entire line is displayed in reverse. The elements of the selection list can be scrolled using the **▲** and **▼** keys. Press **E** to confirm the modification or **ESC** to cancel.

• **Execution of commands**

A parameter can be used to carry out a number of operations on the AFE. For an example, see [paragraph 6.4](#): in this case, the “Press E to execute” request is displayed instead of the value.

To perform the command, press **E**.

During execution of the command, the “In progress” caption is displayed to indicate that the operation is in course.

At the end of execution, if the result is positive, the “Done” caption is displayed for few seconds.

If execution has failed, an error message is displayed.

6.4 How to save parameters

Menu 04 DRIVE CONFIG, parameter 04.01 **Save parameters**, PAR : 550.

Used to save changes to parameter settings so that they are maintained also at the power-off.

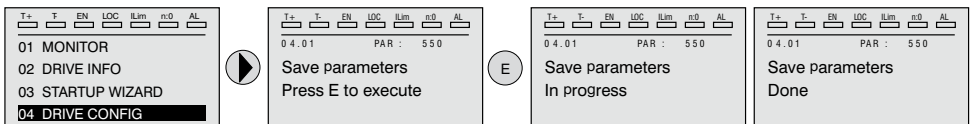

To exit, press the **◀** key.

6.5 Configuration of the display

6.5.1 Language selection

Menu 04 DRIVE CONFIG, parameter 04.17 **Language select**, PAR: 578, default=English.

Used to set one of the languages available : English, Italian, Francais, Deutsch, Polish, Romanian, Russian, Turkish and Portuguese.

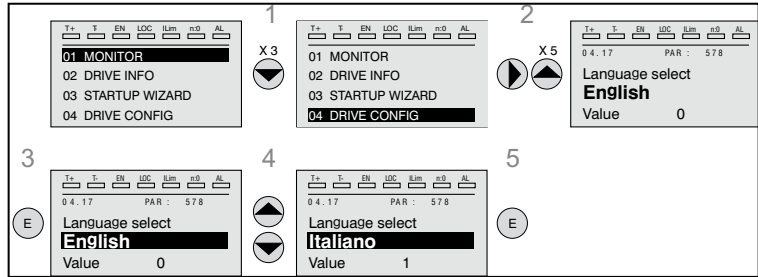

Note !

To access the Cyrillic font : 1) press the E key and hold it down while you switch the AFE on, 2) select the required font using the ▲ and ▼ keys, 3) press E to confirm and return to normal operating mode.

6.5.2 Selection of Easy / Export mode

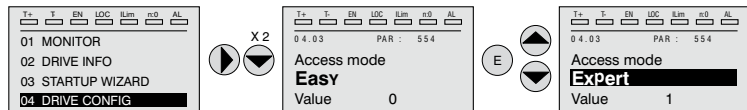

Menu 04 DRIVE CONFIG, parameter 04.03 **Access mode** , PAR: 570.

Makes it possible to configure two methods of access :

Easy (default) only the main parameters are displayed

Expert for advanced users, all the parameters are displayed, see [paragraph 8.1](#) List of Expert parameters.

6.5.3 Startup display

Note !

This parameter is visible only in **Expert** mode (see [paragraph 6.5.2](#))

Menu 04 DRIVE CONFIG, parameter 04.15 **Startup display**, PAR : 574.

Used to set the parameter that will be displayed automatically at AFE power-on. Entering the value -1 (default), the function is disabled and the main menu is displayed at power-on.

6.5.4 Back-lighting of the display

Note !

This parameter is visible only in **Expert** mode (see [paragraph 6.5.2](#)).

Menu 04 DRIVE CONFIG, parameter 04.16 **Display backlight**, PAR : 576.

Sets lighting of the display

ON the light of the display remains always on.

OFF (default) the light switches off after approx. 3 minutes from pressing of the last key.

6.6 Alarms

The alarms page is displayed automatically when an alarm occurs.

	T ₁	T ₂	EM	LOC	sm	sd	AL
1	Alarm -RTN: 1/2						
2	Power down						
3	Code: 0000H-0						
4	Time: 28:04						

- 1 Alarm:** identifies the alarm page.
RTN : indicates that the alarm has been reset; if the alarm is still active, nothing is displayed.
x/y : x indicates the position of this alarm in the list of alarms and y the number of alarms (the alarm with lowest x is the most recent)
- 2** Description of the alarm
- 3** Sub-code of the alarm, provides other information in addition to the description
- 4** Moment of occurrence of the alarm in machine time.

The list of alarms is scrolled using the ▲ and ▼ keys.

6.6.1 Alarm reset

- If the alarm page is displayed:

Pressing the **RST** key, the alarms are reset and all alarms reset are eliminated from the list.

If, after this operation, the list of alarms is empty, the alarm page is closed.

If the list is not empty, press the ► key to exit from the alarms page.

- If the alarms page is not displayed:

Pressing the **RST** key, the alarms are reset.

If active alarms are still present following reset, the alarm page is opened.

Note !

For further information, see [chapter 9](#).

6.7 Messages

Operator messages are displayed with this page.

The messages are of two types:

- *timed* (closed automatically after a certain number of seconds),
- *fixed* (remain displayed until the operator presses the **ESC** key).

Several concurrent messages are enqueued and presented to the operator in sequence, starting from the most recent.

	T+	T	EN	LOC	ILm	nO	AL
1	Message 0 1						
2	Load default						
3	Code: 0001H-1						
4	Press ESC to exit						

- 1 MESSAGE** : identifies a message.
xx indicate show many messages are enqueued. The queue may contain a maximum of 10 messages and the message with the highest number is the most recent.
- 2** Description of the message (see [chapter 9](#) for further information)
- 3** Sub-code of the message. Provides extra information in addition to the description.
- 4** "Press ESC to exit" is displayed if the message requires acknowledgment.

When a message is closed, the next message is displayed until the queue is empty.

Note !

For further information, see [chapter 9](#).

6.8 Saving and recovery of new parameter settings

Drive parameters can be saved on the keypad in 5 different memory areas. This function is useful to obtain various sets of parameters, for safety backup or to transfer the parameters from one AFE to another.

6.8.1 Selection of the keypad memory

T+	T	EN	LOC	ILm	nO	AL		T+	T	EN	LOC	ILm	nO	AL		T+	T	EN	LOC	ILm	nO	AL			
01	MONITOR							▶ ▲	04.21	PAR : 594							E ▲	04.21	PAR : 594						
02	DRIVE INFO								Keypad memory select							Keypad memory select									
03	STARTUP WIZARD								1							00000002									
04	DRIVE CONFIG								Def: 1							Def: 1									

Menu 04 DRIVE CONFIG, parameter 04.21 **Keypad memory select**, PAR : 594.

The keypad features 5 memory areas dedicated to saving parameters. The memory to be used is selected using the **Keypad memory select** parameter. Subsequent saving and recovery operations will be carried out on the memory selected.

6.8.2 Saving of parameters on the keypad

T+	T	EN	LOC	ILm	nO	AL		T+	T	EN	LOC	ILm	nO	AL		T+	T	EN	LOC	ILm	nO	AL			
01	MONITOR							▶ ▲	04.19	PAR : 590							E	04.19	PAR : 590						
02	DRIVE INFO								Save par to keypad							DRIVE --> K2006 X									
03	STARTUP WIZARD								Press E to execute							■■■■■■■■■■■■■■■■■■■■									
04	DRIVE CONFIG																								

Menu 04 DRIVE CONFIG, parameter 04.19 **Save par to keypad**, PAR : 590.

Is used to transfer the parameters from the AFE to the selected keypad memory. To start the operation, press the **E** key. During transfer, a bar is displayed which indicates progress of the operation. Instead of the letter **X**, the number of the currently selected keypad memory is displayed.

At the end of transfer, if this has been completed successfully, the "Done" caption is displayed for a few seconds with subsequent return to the initial page.

If an error occurs during transfer, the following message is displayed:

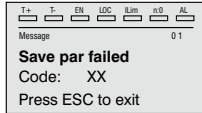

The code XX indicates the type of error, see [paragraph 9.2](#).

To exit from the error message, press the **ESC** key.

6.8.3 Load parameters from keypad

Menu 04 DRIVE CONFIG, parameter 04.20 **Load par from keypad**, PAR : 592.

Is used to transfer the parameters from the selected memory of the keypad to the AFE.

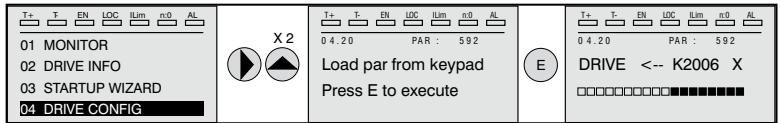

To start the operation, press the **E** key. During transfer, a bar is displayed which indicates progress of the operation.

Instead of the letter **X**, the number of the currently selected keypad memory is displayed.

At the end of transfer, if this has been completed successfully, the “Done” caption is displayed for a few seconds with subsequent return to the initial page.

If an error occurs during transfer, the following message is displayed:

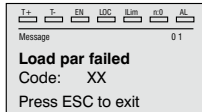

The code XX indicates the type of error, see [paragraph 9.2](#).

To exit from the error message, press the **ESC** key.

6.8.4 Transfer of parameters between AFE200

Transfer the parameters of the source AFE to the keypad memory as indicated in [paragraph 6.8.2](#), then connect the keypad to the AFE on which the new setting is to be saved and proceed as indicated in paragraph 6.8.3.



Caution

To prevent possible damage to equipment, it is advisable to disconnect and connect the keypad with the AFE OFF.

Pour éviter tout endommagement possible des appareils, il est conseillé de débrancher et de brancher le pavé de commande une fois le AFE éteint.

7 - Commissioning via keypad

AFE are electrical apparatus for use in industrial installations. Parts of the AFE are energized during operation. The electrical installation and the opening of the device should therefore only be carried out by qualified personnel. Improper installation of motors or AFE may therefore cause the failure of the device as well as serious injury to persons or material damage. Drive is not equipped with motor overspeed protection logic other than that controlled by software. Follow the instructions given in this manual and observe the local and national safety regulations applicable.

Les AFE à fréquence variable sont des dispositifs électriques utilisés dans des installations industrielles. Une partie des AFE sont sous tension pendant l'opération. L'installation électrique et l'ouverture des AFE devrait être exécuté uniquement par du personnel qualifié. De mauvaises installations de moteurs ou de AFE peuvent provoquer des dommages matériels ou blesser des personnes. On doit suivre les instructions données dans ce manuel et observer les règles nationales de sécurité.

Always connect the AFE to the protective ground (PE) via the marked connection \perp . AFE200 product and AC Input filters have ground discharge currents greater than 3.5 mA. EN 50178 specifies that with discharge currents greater than 3.5 mA the protective conductor ground connection (\perp) must be fixed type and doubled for redundancy.

Il faut toujours connecter les variateurs et les AFE à la terre \perp (PE). Le courant de dispersion vers la terre est supérieur à 3,5 mA sur les variateurs et sur les filtres à courant alternatif. Les normes EN 50178 spécifient qu'en cas de courant de dispersion vers la terre, supérieur à 3,5 ma, la mise à la terre (\perp) doit avoir une double connexion pour la redondance.

Only permanently-wired input power connections are allowed. This equipment must be grounded (IEC 536 Class 1, NEC and other applicable standards).

If a Residual Current-operated protective Device (RCD) is to be used, it must be an RCD type B. Machines with a three phase power supply, fitted with EMC filters, must not be connected to a supply via an ELCB (Earth Leakage Circuit-Breaker - see DIN VDE 0160, section 5.2.2 and EN50178 section 5.2.11.1).

The following terminals can carry dangerous voltages even if the AFE200 is inoperative:

- output terminals C, D.
- line terminals U, V, W.

This equipment must not be used as an 'emergency stop mechanism' (see EN 60204, 9.2.5.4).

Seuls des branchements électriques permanents par câble en entrée sont admis. Mettre l'appareil à la masse (IEC 536 Classe 1, NEC et autres normes applicables).

S'il s'avère nécessaire d'utiliser un dispositif protecteur de courant résiduel (RCD), il convient de choisir un RCD de type B. Les machines à alimentation triphasée et dotées de filtres EMC ne doivent pas être raccordées au bloc d'alimentation par le biais d'un disjoncteur ELCB (Earth Leakage Circuit-Breaker – cf. DIN VDE 0160, paragraphe 5.5.2 et EN50178 paragraphe 5.2.11.1).

Les bornes suivantes peuvent recevoir des tensions dangereuses, même si l'onduleur est désactivé :

- bornes d'e sortie C, D.
- bornes d'alimentation U, V, W.

Ne pas utiliser cet appareil en tant que « dispositif d'arrêt d'urgence » (cf. EN 60204, 9.2.5.4).

Do not touch or damage any components when handling the device. The changing of the isolation gaps or the removing of the isolation and covers is not permissible.

Manipuler l'appareil de façon à ne pas toucher ou endommager des parties. Il n'est pas permis de changer les distances d'isolement ou bien d'enlever des matériaux isolants ou des capots. According to the EEC standards the AFE200 and accessories must be used only after

checking that the machine has been produced using those safety devices required by the 89/392/EEC set of rules, as far as the machine industry is concerned. These standards do not apply in the Americas, but may need to be considered in equipment being shipped to Europe.

Selon les normes EEC, les AFE200 et leurs accessoires doivent être employés seulement après avoir vérifié que la machine ait été produite avec les mêmes dispositifs de sécurité demandés par la réglementation 89/392/EEC concernant le secteur de l'industrie.

AFE200 operate at high voltages.

L'AFE200 fonctionne à des tensions élevées.

When operating electrical devices, it is impossible to avoid applying hazardous voltages to certain parts of the equipment.

L'actionnement de dispositifs électriques fait qu'il est impossible d'éviter l'application de tensions dangereuses sur certaines parties de l'appareil.

Wherever faults occurring in the control equipment can lead to substantial material damage or even grievous bodily injury (i.e. potentially dangerous faults), additional external precautions must be taken or facilities provided to ensure or enforce safe operation, even when a fault occurs (e.g. independent limit switches, mechanical interlocks, etc.).

Adopter des mesures de précaution supplémentaires à l'extérieur du drive (par exemple, des interrupteurs de fin de course, des interrupteurs mécaniques, etc.) ou fournir des fonctions aptes à garantir ou à mettre en place un fonctionnement sécurisé en cas de survenue d'une panne de l'appareil de commande susceptible d'occasionner des dégâts matériels d'envergure, voire même des lésions corporelles graves (par exemple, des pannes potentiellement dangereuses).

Certain parameter settings may cause the AFE200 to restart automatically after an input power failure.

Certaines configurations de paramètres peuvent provoquer le redémarrage automatique de l'onduleur après une coupure de l'alimentation.

This equipment is suitable for use in a circuit capable of delivering not more than 10,000 symmetrical amperes (rms), for a maximum voltage of 480 V .

Cet appareil est conçu pour une utilisation sur un circuit d'alimentation en mesure de délivrer 10.000 ampères symétriques (rms) maximum pour une tension maximale de 480V.

This equipment must not be used as an 'emergency stop mechanism' (see EN 60204, 9.2.5.4).

Ne pas utiliser cet appareil en tant que « dispositif d'arrêt d'urgence » (cf. EN 60204, 9.2.5.4).

Never open the device or covers while the AC Input power supply is switched on. Minimum time to wait before working on the terminals or inside the device is listed in [section 10.6](#) .

Ne jamais ouvrir l'appareil lorsqu'il est sous tension. Le temps minimum d'attente avant de pouvoir travailler sur les bornes ou bien à l'intérieur de l'appareil est indiqué dans la [section 10.6](#) .

Fire and Explosion Hazard:

Fires or explosions might result from mounting AFE in hazardous areas such as locations where flammable or combustible vapors or dusts are present. AFE should be installed away from hazardous areas, even if used with motors suitable for use in these locations.

***Risque d'incendies et d'explosions.** L'utilisation des AFE dans des zones à risques (présence de vapeurs ou de poussières inflammables), peut provoquer des incendies ou des explosions. Les AFE doivent être installés loin des zones dangereuses, et équipés de moteurs appropriés.*



Protect the device from impermissible environmental conditions (temperature, humidity, shock etc.).

Protéger l'appareil contre des effets extérieurs non permis (température, humidité, chocs etc.).

To the output of the AFE (terminals C, D):

- the direct connection of the inputs and outputs (bypass) are not permissible.

À la sortie du AFE (bornes C, D)

- il n'est pas permis de raccorder la sortie de plusieurs convertisseurs en parallèle

The electrical commissioning should only be carried out by qualified personnel, who are also responsible for the provision of a suitable ground connection and a protected power supply feeder in accordance with the local and national regulations. The motor must be protected against overloads.

La mise en service électrique doit être effectuée par un personnel qualifié. Ce dernier est responsable de l'existence d'une connexion de terre adéquate et d'une protection des câbles d'alimentation selon les prescriptions locales et nationales. Le moteur doit être protégé contre la surcharge.

Do not connect power supply voltage that exceeds the standard specification voltage fluctuation permissible. If excessive voltage is applied to the AFE, damage to the internal components will result.

Ne pas raccorder de tension d'alimentation dépassant la fluctuation de tension permise par les normes. Dans le cas d'une alimentation en tension excessive, des composants internes peuvent être endommagés.

Do not operate the AFE without the ground wire connected.

Ne pas faire fonctionner le AFE sans prise de terre.

No dielectric tests should be carried out on parts of the AFE. A suitable measuring instrument (internal resistance of at least 10 k Ω /V) should be used for measuring the signal voltages.

Il ne faut pas exécuter de tests de rigidité diélectrique sur des parties du AFE. Pour mesurer les tensions, des signaux, il faut utiliser des instruments de mesure appropriés (résistance interne minimale 10k Ω /V).

7.1 Startup Wizard

Introduction

The startup wizard is a guided procedure used for quick start-up of the AFE that helps to set the main parameters.

It consists of a series of questions relating to the various sequences for entering and calculating the parameters necessary for correct AFE operation.

The order of these sequences is as follows:

- Basic connections [See step 1](#)
- **Setting of the capacitor value** [See step 2](#)
- **Setting of the choke value** [See step 3](#)
- **Setting of the DC-link parameters** [See step 4](#)
- **Saving parameters** [See step 5](#)

The format of the function selection page is as follows:



Pressing the E key, the function to be programmed is accessed.

Press the ▼ (Down) key to move to the next function skipping the current function.

Press the ▲ key to return to the previous function.

To terminate the sequence of functions and return to the menu, press the **ESC** key.

The end of the start-up sequence is indicated with the page:

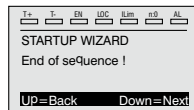

Press the ▼(Down) key to exit the sequence and return to the menu.

Note !

.....
In the procedures described below, the settings have been made using the AFE200-4450.
.....

Step 1 - Connections

Connect the power supply line and enabling contacts as shown in the diagram in chapter 5.4.1.

Checks to be performed before powering the AFE

- Check that the supply voltage is correct and that the output terminals on the AFE (C, D) are connected correctly.
- Check that all the AFE control circuit terminals are connected correctly. Check that all control inputs are open.

Powering the AFE

- After completing all the checks described above, power the AFE and proceed to Step 2.

Step 2 - Setting of the capacitor value

The factory setting for the AFE200 capacitor value is displayed. The capacitor values of the drives connected to the DC BUS must be added to this (value of the DC-link capacitors). See table **"10.5 DC circuit" on page 169**.



At the end of the procedure, proceed to Step 3.

Step 3 - Setting of the choke value

The set value is the sum of line inductance value + LR3-AFE inductance as per chapter **"5.6 LCL Filters" on page 51**.

If units are connected in parallel, the sum is:
 $L\text{-AFE} + LR3\text{-AFE} / \text{Number of units in parallel}$.

To change this value, type **Enter** and follow the instructions or press ▼ to go to step 4.

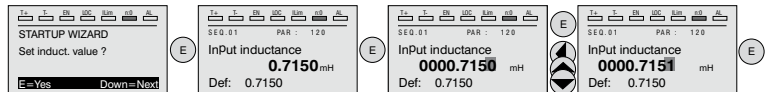

Step 4 - Setting of the DC-link parameter

The factory settings for the DC-link voltage (as a function of the mains voltage) and acceleration and deceleration times are proposed in sequence. To change the value type Enter and follow the instructions or press ▼ to go to the next step.

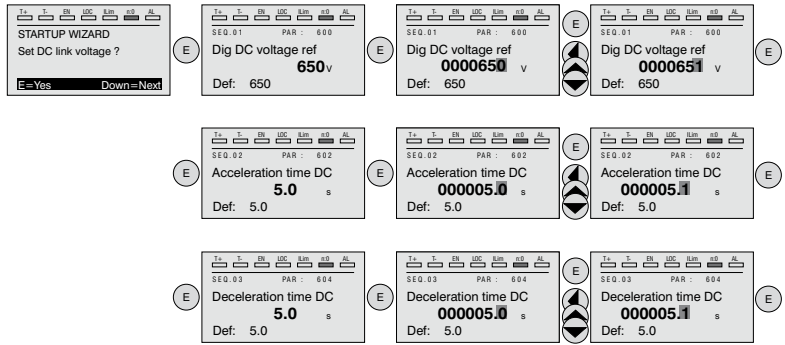

At the end of the procedure, proceed to Step 5.

Step 5 - Saving parameters (Save parameters)

To save the new parameter settings, so that they are maintained also after power-off, proceed as follows:

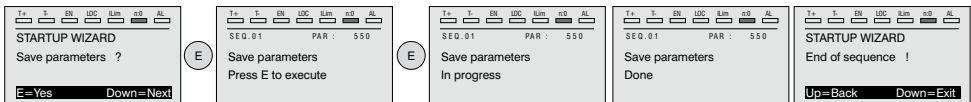

7.2 Programming

7.2.1 Menu display modes

The programming menu can be displayed in two modes, which can be selected using the **Access mode** parameter (04 - DRIVE CONFIG menu), see [chapter 6.5.2](#):

- **Easy** (default) only the main parameters are displayed.
- **Expert** all the parameters are displayed.

7.2.2 Programming of “function block” analog and digital input signals

The signals, variables and parameters of each single “function block” of the AFE are interconnected in order to achieve the configurations and controls inside the control system.

These can be managed and modified using the keypad, PC configurator or fieldbus programming.

The programming mode is based on the following logic:

src (source; i.e.: **DC voltage ref src**, PAR: 608)
This term defines **the source of the function block input**, i.e. the signal to be processed in the function block.
The different configurations are defined in the relative **selection lists**.

mon (display; i.e.: **Analog input 1 mon** PAR: 1500)
This term refers to the **variable output from the function block**, which is the result of the calculations performed on the actual block.

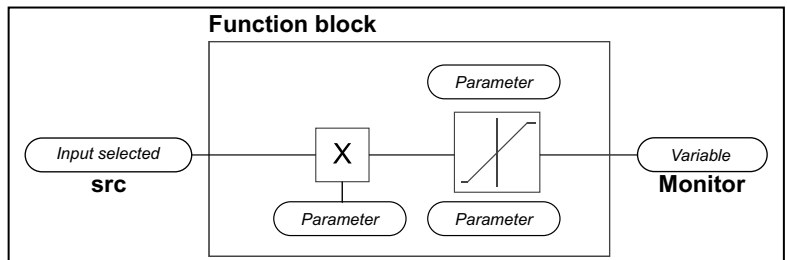

7.2.3 Variable interconnections mode

The **source (src)** allows the desired control signal to be assigned to the function block input.

This operation is performed by using specific selection lists.

Possible control signal sources:

1 – Physical terminal

The analog and digital signals come from the terminal strip of the regulation card and/or from those of the expansion cards.

2 – Drive internal variables

Internal AFE control system variables, from “function block” calculations, sent via keypad, PC configurator or fieldbus.

Practical example

The following examples illustrate the philosophies and methods with which more or less complex operations are performed in the single “function blocks”, the results of which represent the output of the block.

• Example: Inverting the analog reference signal

To invert the “**Analog input 1 Block**” output signal, the value of the **An inp 1 sign** parameter (PAR: 1526), which has a default setting of **Null** (no operation), must be changed by selecting the source of the command signal from among those listed in the L_DIGSEL 2 selection list, for example **Digital input X mon**, **One** (function always enabled), etc.

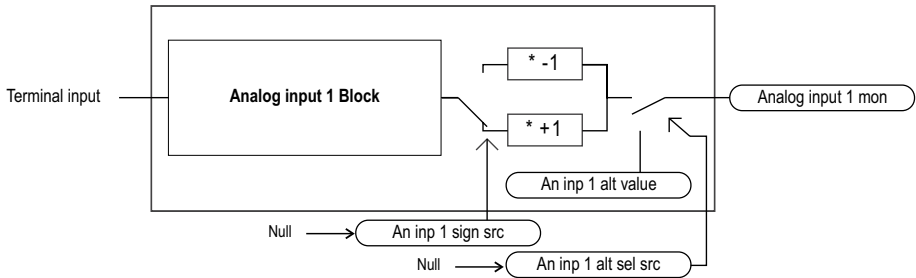

Note !

||||| This section contains a brief description of the functions of the other parameters in the function blocks not included for the changes in the example. |||||

The **An inp 1 alt sel src** parameter (PAR: 1528) can be used to select an alternative reference for the **Analog input 1 mon** (PAR: 1500) output.

The **An inp 1 alt value** parameter (PAR: 1524) determines the alternative reference value for the **Analog input 1 mon** (PAR: 1500) output.

8 - Description of parameters and functions (Expert list)

Legend

①	②	③	④	⑤	⑥	⑦	⑧	⑨	
Menu	PAR	Description	UM	Type	FB BIT	Def	Min	Max	Acc
1 - MONITOR				<i>(Level 1 menu)</i>					
1.1	250	Output current	A	FLOAT	16/32	0.0	0.0	0.0	R
1.2	252	Output voltage	V	FLOAT	16/32	0.0	0.0	0.0	R
13.2 - FUNCTIONS/DOUBLE PAR SET				<i>(Level 2 menu)</i>					
13.2.1	3300	Par set enable		ENUM		Disable	0	1	ERW
13.2.2	3302	Par set select src		LINK	16	6000	0	16384	ERWZ
				L DIGSEL2		<i>(Selection list) [*]</i>			

①	Indexing of the menu and parameter	⑥	Default value
②	Parameter identifier	⑦	Minimum value
③	Parameter description	⑧	Maximum value
④	UM: unit of measure	⑨	Accessibility : E Expert R Read S Size (set value depending on the size of the device) W Write Z parameters that can be modified ONLY with the AFE disabled
	Type of parameter BIT Boolean, from modbus seen as 16 bits ENUM Selection list, from modbus seen as 16 bits FLOAT Real, from modbus seen as 32 bits FBM2SIPA 16-bit unsigned integer. Only PAR of existing parameters accepted. FBS2MIPA 16-bit unsigned integer. Only PAR of existing parameters accepted. INT16 Integer with sign 16 bits, from modbus seen as 16 bits INT32 Integer with sign 32 bits, from modbus seen as 32 bits ILINK Selection list, from modbus seen as 32 bits LINK Selection list, from modbus seen as 16 bits UINT16 Integer without sign 16 bits, from modbus seen as 16 bits UINT32 Integer without sign 32 bits, from modbus seen as 32 bits		
⑤	Format of data exchanged on Fieldbus (16BIT, 32BIT)	[*]	Selection lists: The "... src" format parameters are linked to a selection list. The source of the signal that will control the parameter can be selected from the list indicated. The lists are indicated in paragraph 8.5 of this manual.

1 - MONITOR

The monitor menu displays the measured values of the sizes and of the AFE operating parameters.

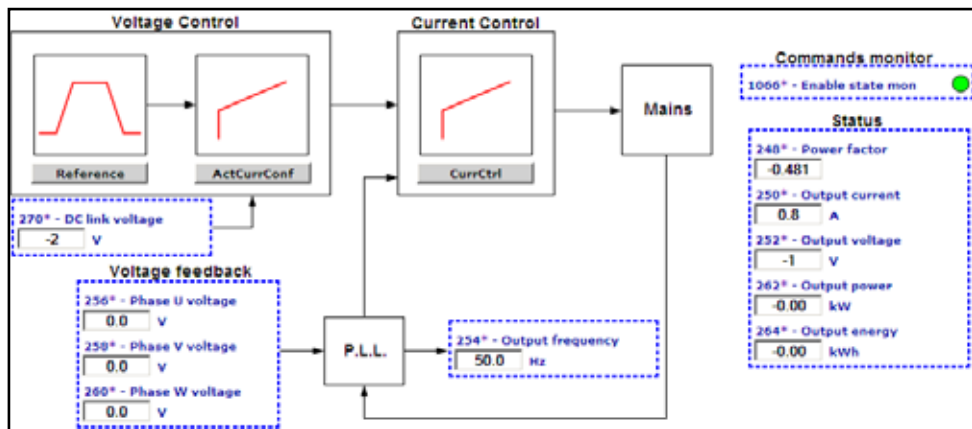

Menu	PAR	Description	UM	Type	FB BIT	Def	Min	Max	Acc
1.1	250	Output current	A	FLOAT	16/32	0.0	0.0	0.0	R

The AFE output current is displayed.

Menu	PAR	Description	UM	Type	FB BIT	Def	Min	Max	Acc
1.2	252	Output voltage	V	FLOAT	16/32	0.0	0.0	0.0	R

Display of daisy-chained output voltage (*) of AFE.

(*) tensione generata dall'inverter sul lato AC.

Menu	PAR	Description	UM	Type	FB BIT	Def	Min	Max	Acc
1.3	254	Output frequency	Hz	FLOAT	16/32	0.0	0.0	0.0	R

Display of output frequency (*) of AFE.

(*) frequency of 3-phase AC grid to which AFE is connected.

Menu	PAR	Description	UM	Type	FB BIT	Def	Min	Max	Acc
1.4	270	DC link voltage	V	FLOAT	16/32	0.0	0.0	0.0	ER

The direct voltage of the intermediate circuit capacitors is displayed (DC-Bus).

Menu	PAR	Description	UM	Type	FB BIT	Def	Min	Max	Acc
1.5	272	Heatsink temperature	degC	INT16	16	0	0	0	ER

Display of the temperature measured by the linear transducer, integrated on IGBT modules.

Menu	PAR	Description	UM	Type	FB BIT	Def	Min	Max	Acc
1.6	280	Active current ref	A	FLOAT	16/32	0.0	0.0	0.0	ER

The active current reference is displayed.

Menu	PAR	Description	UM	Type	FB BIT	Def	Min	Max	Acc
1.7	282	React curr ref mon	A	FLOAT	16/32	0.0	0.0	0.0	ER
The reactive current reference is displayed.									
1.8	284	Active current	A	FLOAT	16/32	0.0	0.0	0.0	ER
The active current value currently in use is displayed.									
1.9	286	Reactive current	A	FLOAT	16/32	0.0	0.0	0.0	ER
The reactive current value currently in use is displayed.									
1.10	256	Phase U voltage	V	FLOAT	16/32	0.0	0.0	0.0	R
The phase U voltage is displayed.									
1.11	258	Phase V voltage	V	FLOAT	16/32	0.0	0.0	0.0	R
The phase V voltage is displayed.									
1.12	260	Phase W voltage	V	FLOAT	16/32	0.0	0.0	0.0	R
The phase W voltage is displayed.									
1.13	248	Power factor		FLOAT		0.0	0.0	0.0	ER
The power factor value ($\cos\phi$) is displayed.									
1.14	262	Output power	kW	FLOAT	16/32	0.0	0.0	0.0	ER
The value of the power generated into the mains is displayed.									
1.15	264	Output energy	kWh	FLOAT		0.0	0.0	0.0	ER
The value of the energy generated onto the mains is displayed.									
1.16	368	Drive overload accum	perc	UINT16	16/32	0	0	100	ER
The AFE overload level is displayed. An instantaneous overload of 180% of the AFE rated current is allowed for 0.5s. The thermal image I ² t adjusts the AFE output current thresholds. During normal operation, the instantaneous output current value can reach 180% of the AFE rated current. After 0.5s at 180%, the output current threshold is reduced to 150%. When the overload level PAR 368 Drive overload accum reaches 100%, the output current threshold is reduced to 100% of the rated current, and stays at that value until the I ² t integrator cycle is complete. At this point the 180% instantaneous overload is re-enabled.									

Menu	PAR	Description	UM	Type	FB BIT	Def	Min	Max	Acc
1.17	1066	Enable state mon		BIT	16	0	0	1	R
<p>The AFE Enable command status is displayed. Voltage must be present on terminal 7. The FR Forwardstart command is needed to start the AFE200.</p> <p>0 Disabled AFE disabled 1 Enabled AFE enabled</p>									

Menu	PAR	Description	UM	Type	FB BIT	Def	Min	Max	Acc
1.18	1100	Digital input mon		UINT16	16	0	0	0	R
<p>The status of the digital inputs on the AFE is displayed. It can also be read via a serial line or fieldbus. The data are contained in a word, where each bit is 1 if voltage is supplied to the corresponding input terminal.</p> <p>0 Input disabled 1 Input enabled</p>									

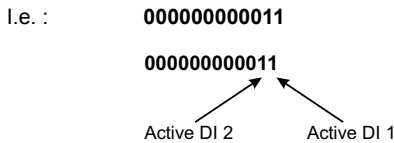

Menu	PAR	Description	UM	Type	FB BIT	Def	Min	Max	Acc
1.19	1300	Digital output mon		UINT16		0	0	0	R
<p>The status of the digital outputs on the AFE is displayed. It can also be read via a serial line or fieldbus. The data are contained in a word, where each bit is 1 if voltage is supplied to the corresponding input terminal.</p> <p>0 Output disabled 1 Output enabled</p>									

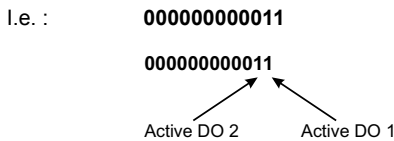

Menu	PAR	Description	UM	Type	FB BIT	Def	Min	Max	Acc
1.20	1200	Digital input X mon		UINT16	16	0	0	0	R
<p>The status of the digital inputs of the expansion card is displayed. It can also be read via a serial line or fieldbus. The data are contained in a word, where each bit is 1 if voltage is supplied to the corresponding input terminal.</p> <p>0 Input disabled 1 Input enabled</p>									



Menu	PAR	Description	UM	Type	FB BIT	Def	Min	Max	Acc
1.21	1400	Digital output X mon		UIN16		0	0	0	R

The status of the digital outputs of the expansion card is displayed. It can also be read via a serial line or fieldbus. The data are contained in a word, where each bit is 1 if voltage is supplied to the corresponding input terminal.

- 0 Output disabled
- 1 Output enabled

I.e. : **00000000011**

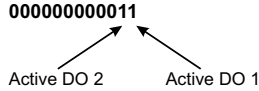

Menu	PAR	Description	UM	Type	FB BIT	Def	Min	Max	Acc
1.22	5400	Dig inp 0Ext mon		UIN32	32BIT	0	0	4294967295	ER

This parameter displays the state of external inputs from 0 to 31 through the use of EXP-FL-XCAN-ADV optional card.

Menu	PAR	Description	UM	Type	FB BIT	Def	Min	Max	Acc
1.23	5402	Dig inp 1Ext mon		UIN32	32BIT	0	0	4294967295	ER

This parameter displays the state of external inputs from 32 to 63 through the use of EXP-FL-XCAN-ADV optional card.

Menu	PAR	Description	UM	Type	FB BIT	Def	Min	Max	Acc
1.24	5450	Digital out 0Ext mon		UIN32	32BIT	0	0	0	ER

This parameter is used to read the state of external outputs from 0 to 31 through the use of EXP-FL-XCAN-ADV optional card.

Menu	PAR	Description	UM	Type	FB BIT	Def	Min	Max	Acc
1.25	5452	Digital out 1Ext mon		UIN32	32BIT	0	0	0	ER

This parameter is used to read the state of external outputs from 32 to 63 through the use of EXP-FL-XCAN-ADV optional card.

Menu	PAR	Description	UM	Type	FB BIT	Def	Min	Max	Acc
1.26	1060	Sequencer status		ENUM	16	Init	0	0	ER

Drive state parameter. Provides the AFE's operating and activation state and is responsible for protection and alarm conditions, the command sequence and reset condition.

- 0 Init
- 1 Wait Vdc Ok
- 2 Delay
- 3 Offset Calc
- 4 Ready
- 5 Run
- 6 Alarm Disabled
- 7 Alm End Action
- 8 Alm return
- 9 Alm no restart

2 - DRIVE INFO

This menu displays the information for identifying and configuring the AFE.

Menu	PAR	Description	UM	Type	FB BIT	Def	Min	Max	Acc
2.1	482	Drive size		UINT16		0	0	0	RS

The AFE size identification code is displayed.

Menu	PAR	Description	UM	Type	FB BIT	Def	Min	Max	Acc
2.2	484	Drive family		ENUM		No Power	0	0	RS

The available mains voltage is displayed (e.g. 400V). The undervoltage alarm refers to this voltage value.

The condition **No power** occurs when the regulation board has just left from production and has never been configured for any power. The configuration adjustment for a given power is achieved by linking it to a power board and running a **Save parameters**.

- 0 No Power
- 1 380V..480V
- 2 500V..575V
- 3 690V
- 4 230V
- 5 270V

Menu	PAR	Description	UM	Type	FB BIT	Def	Min	Max	Acc
2.3	486	Drive region		ENUM		EU	0	1	R

Setting of the geographical area in which the AFE is to be used (Europe or USA). This setting determines the factory voltage and power supply frequency values (e.g. when set to 0 the default voltage is 400V and frequency 50Hz).

- 0 EU
- 1 USA

Menu	PAR	Description	UM	Type	FB BIT	Def	Min	Max	Acc
2.4	488	Drive cont current	A	FLOAT		CALCF	0.0	0.0	RZS

The current that the AFE can deliver continuously according to size, supply voltage and programmed switching frequency is displayed.

Menu	PAR	Description	UM	Type	FB BIT	Def	Min	Max	Acc
2.5	490	Firmware ver.rel		UINT16		0	0	0	R

The version number and release number of the AFE firmware are displayed. On the keypad these are displayed in the version.release format. The parameter reading from the serial communication device or fieldbus returns the version in the high byte and the release in the low byte.

Menu	PAR	Description	UM	Type	FB BIT	Def	Min	Max	Acc
2.6	496	Firmware type		UINT16		0	0	0	R

The type of firmware installed in the AFE is displayed.

Menu	PAR	Description	UM	Type	FB BIT	Def	Min	Max	Acc
2.7	504	Application ver.rel		UINT16		0	0	0	ER
		The version number and release number of the application are displayed.							
2.8	506	Application type		UINT16		0	0	0	ER
		The type of application currently used by the AFE is displayed.							
2.9	508	Actual date time		UINT32		0	0	0	R
		Displays current date and time, in the format "dd/MM/yyyy hh.mm.ss". Parameter only available if installed option "RTC-ADV".							
2.10	510	Time drive power on	h.min	UINT32		0	0	0	ER
		The total time for which the AFE has been powered is displayed.							
2.11	512	Time drive enable	h.min	UINT32		0	0	0	ER
		The time for which the enable hardware contact on the AFE has been connected is displayed.							
2.12	514	Number power up		UINT16		0	0	0	ER
		The number of times the AFE has been powered on is displayed.							
2.13	516	Time fan on	h.min	UINT32		0	0	0	ER
		The total operating time of the AFE fan is displayed.							
2.14	520	Product S/N		UINT32		0	0	0	R
		The AFE serial number is displayed.							
2.15	522	Regulation S/N		UINT32		0	0	0	R
		The AFE regulation card serial number is displayed.							
2.16	524	Power S/N		UINT32		0	0	0	R
		The AFE power card serial number is displayed.							
2.17	526	Power file ver.rel		UINT16		0	0	0	ER
		The version number and release number of the AFE power card are displayed.							

Menu	PAR	Description	UM	Type	FB BIT	Def	Min	Max	Acc
2.18	530	Slot1 card type		ENUM		None	0	0	R
2.19	532	Slot2 card type		ENUM		None	0	0	R
2.20	534	Slot3 card type		ENUM		None	0	0	R

The type of expansion card installed in the relative slot of the AFE is displayed.

0	None	
769	I/O 1	(EXP-IO-D6A4R1-ADV)
1793	I/O 2	
2305	I/O 3	
3329	I/O 4	
4	Can/Dnet	(EXP-CAN-ADV)
260	Profibus	(EXP-PDP-ADV)
32	Fast IO	
288	Exp sync 1	(*)
544	Exp sync 2	(*)
800	Exp sync 2.1	(*)
516	RTE	(EXP-ETH-...)
255	Unknown	
576	FastLink	
320	I/O Ext	
832	I/O FastLink	(EXP-FL-XCAN-ADV)

(*) EXP-SYNC-ADV cards			
FW AFE200	Exp sync 2.1	Exp sync 2	Exp sync 1
≥ 7.x.4	X	X	X
= 7.x.2	0	X	X
≤ 7.x.0	0	0	X

X = compatible, 0 = not compatible

Menu	PAR	Description	UM	Type	FB BIT	Def	Min	Max	Acc
2.21	536	Slot1 card S/N		UINT32		0	0	0	R
2.22	538	Slot2 card S/N		UINT32		0	0	0	R
2.23	540	Slot3 card S/N		UINT32		0	0	0	R

The serial number of the expansion card installed in the relative slot of the AFE is displayed.

Menu	PAR	Description	UM	Type	FB BIT	Def	Min	Max	Acc
2.24	5724	Fw FastLink ver.rel		UINT16		0	0	0	ER

The version and release number of the FastLink card firmware installed in the drive are displayed.

When the parameter is read via serial line or fieldbus the version is returned in the high byte and the release in the low byte.

Menu	PAR	Description	UM	Type	FB BIT	Def	Min	Max	Acc
2.25	5726	Fw FastLink type		UINT16		0	0	0	ER

The type of FastLink card firmware installed in the drive is displayed.

3 - STARTUP WIZARD

The startup wizard menu suggests a procedure for commissioning the AFE quickly with a reduced number of settings. Advanced customization requires the use of the single parameters relating to the specific performance levels. See the procedure described in the previous **Startup wizard** chapter.

4 - CONFIG DRIVE

Menu	PAR	Description	UM	Type	FB BIT	Def	Min	Max	Acc
4.1	550	Save parameters		BIT		0	0	1	RW

Any changes to parameter values immediately affect AFE operations, but are not automatically saved in the permanent memory.

The "Save Parameters" command is used to save current parameter values in the permanent memory.

Any changes that are not saved will be lost when the AFE is switched off.

To save parameters follow the procedure described in STEP 6 of the Startup wizard.

Menu	PAR	Description	UM	Type	FB BIT	Def	Min	Max	Acc
4.2	554	Access mode		ENUM		Facile	0	1	RW

With this parameter you can restrict access to advanced configuration.

0 Easy

1 Expert

The **Easy** mode gives access to a list of parameters that can be used for rapid AFE commissioning. This type of configuration is suitable for the majority of applications. Setting the parameter to **Expert** gives access to all the parameters in the firmware. This mode allows an extremely high level of customization to be achieved in order to exploit the potential of the AFE200 to the full.

Menu	PAR	Description	UM	Type	FB BIT	Def	Min	Max	Acc
4.3	120	Input inductance	mH	FLOAT		CALCF	0.0	0.0	RWZS

This value must be the sum of line inductance value + LR3-AFE inductance as per chapter "5.6 LCL Filters" on page 51.

If units are connected in parallel, the sum is:

$L\text{-AFE} + LR3\text{-AFE} / \text{Number of units in parallel.}$

Menu	PAR	Description	UM	Type	FB BIT	Def	Min	Max	Acc
4.4	458	DC link capacitor	uF	FLOAT		SIZE	0.0	0.0	RWZS

Setting of the value of the DC-link capacitors.

Menu	PAR	Description	UM	Type	FB BIT	Def	Min	Max	Acc
4.5	2020	Take parameters		BIT		0	0	1	RWZ

Stores the choke and capacitor settings. This command must be supplied last after entering the appropriate values of all the parameters listed above. This involves calculating the voltage and current regulator gains. The AFE cannot be started until the **Take parameters** command has been set.

Note!

.....
 This is not saved permanently. Use the "Save Parameters" command in the DRIVE CONFIG menu to save in the permanent memory.

Menu	PAR	Description	UM	Type	FB BIT	Def	Min	Max	Acc
4.6	2028	Take status		ENUM		Required	0	0	R

Indication of the status of parameter saving.

0 Required

1 Done

The parameter displays the **Required** message when the motor parameters that have been entered need to be saved. When they have been saved the parameter indicates **Done**.

Menu	PAR	Description	UM	Type	FB BIT	Def	Min	Max	Acc
4.7	558	Application select		ENUM		None	0	2	ERWZ

Selection of which IEC 61131-3-compliant application to make operational.

- 0 None
- 1 Application 1
- 2 Application 2

Note!

.....
 The Load Default command (par. 580) does not modify this parameter

Menu	PAR	Description	UM	Type	FB BIT	Def	Min	Max	Acc
4.8	560	Mains voltage		ENUM		400 V	SIZE	SIZE	ERWZS

Setting of the available mains voltage value in Volts. Detection of the undervoltage alarm refers to this value.

- 0 320 V
- 1 270 V
- 2 290 V
- 3 230 V
- 4 380V
- 5 400 V
- 6 415 V
- 7 440 V
- 8 460 V
- 9 480 V
- 10 500 V
- 11 575 V
- 12 690 V

Menu	PAR	Description	UM	Type	FB BIT	Def	Min	Max	Acc
4.9	552	Mains frequency		ENUM		50 Hz	0	1	ERWZS

Setting of the value of the available mains frequency in Hz.

- 0 50 Hz
- 1 60 Hz

Menu	PAR	Description	UM	Type	FB BIT	Def	Min	Max	Acc
4.10	562	Switching frequency		ENUM		SIZE	SIZE	SIZE	ERWS

Setting of the switching frequency value in kHz. The maximum value that can be set depends on the size of the AFE.

This must not be changed because changing the default setting may affect performance of the LCL filter.

- 0 1 kHz
- 1 2 kHz
- 2 3 kHz

- 3 4 kHz
- 4 6 kHz
- 5 8 kHz
- 6 10 kHz
- 7 12 kHz
- 8 16 kHz

Menu	PAR	Description	UM	Type	FB BIT	Def	Min	Max	Acc
4.11	564	Ambient temperature		ENUM		40 degC	0	1	ERWZ
		Setting of the ambient temperature value. This parameter is used to set the output current derating factor (1% for every °C above 40°C).							
		0		40 degC					
		1		50 degC					
		40 degC The AFE200 is capable of delivering direct current continuously with ambient temperatures of up to 40°C.							
		50 degC The AFE200 is capable of delivering direct current continuously with ambient temperatures of up to 50°C.							
		If the value is set to 1 the AFE output current will be 10% less than the rated current at 40°C.							

Menu	PAR	Description	UM	Type	FB BIT	Def	Min	Max	Acc
4.12	566	Drive overload mode		ENUM		Heavy duty	1	2	ERWZ
		Setting of the overload that can be supplied by the AFE, depending on the application.							
		1		Heavy duty					
		2		Light duty					
		Set Heavy duty when a large overload is requested: the AFE can supply 180% of the rated current for 0.5 seconds and 150% for 1 minute every 5 minutes.							
		Select Light duty to enable the AFE to deliver a current of 110% of the rated current for 1 minute every 5 minutes.							
		LCL must be ordered indicating the use of the AFE overload: Heavy Duty or Light Duty. Changing the default value may impact on the LCL input filter operation.							

Menu	PAR	Description	UM	Type	FB BIT	Def	Min	Max	Acc
4.13	570	Password		UINT32		0	0	99999	ERW
		You can enter a password to protect the parameters from unauthorized tampering: the password can consist of a combination of a maximum of any 5 figures that can be selected by the user. All parameters are locked, except this one and Save parameters .							
		After entering the password, press the E key once to enter it into the memory and again to enable it (= Enabled is displayed to indicate that the password is enabled).							
		So that the password remains valid even after switching the unit off and then switching it back on, save it using the Save parameters command.							
		When the password is enabled any attempts to modify a parameter are blocked and the Password enabled message is displayed.							
		To disable the password, enter the Password parameter (572) in the DRIVE CONFIG menu.							
		Check that the password is enabled (Enabled), press E and enter the combination of figures that make up the password.							
		Press E again. A message is displayed telling you the password is no longer enabled (Disabled).							
		To make sure the password continues to be disabled even after switching the unit off and then switching it back on, save this configuration using the Save parameters command.							
		When an incorrect password is entered, the Password wrong message is displayed.							

Menu	PAR	Description	UM	Type	FB BIT	Def	Min	Max	Acc
4.14	574	Startup display		INT16		-1	-1	20000	ERW

It is possible to set the parameter that will automatically be displayed when the AFE is switched on. If set to -1 the AFE moves to the display menu.

Menu	PAR	Description	UM	Type	FB BIT	Def	Min	Max	Acc
4.15	576	Display backlight		BIT		0	0	1	ERW

Enabling of the backlight on the AFE display.

If set to **0** the display backlight will go off when the AFE has been on for three minutes. If set to **1** the backlight will stay on for as long as the AFE is powered.

Menu	PAR	Description	UM	Type	FB BIT	Def	Min	Max	Acc
4.16	578	Language select		ENUM		English	0	9	RWZ

Setting of the AFE programming language.

- 0** English
- 1** Italiano
- 2** Francais
- 3** Deutsch
- 4** Espanol
- 5** Polish
- 6** Romanian
- 7** Russian
- 8** Turkish
- 9** Portuguese

Note!

.....
 The Load Default command (par. 580) does not modify this parameter.

Menu	PAR	Description	UM	Type	FB BIT	Def	Min	Max	Acc
4.17	580	Load default		BIT		0	0	1	RWZ

Transfers the standard factory settings to the AFE memory ("Def" column in the parameters table).

Menu	PAR	Description	UM	Type	FB BIT	Def	Min	Max	Acc
4.18	590	Save par to keypad		BIT		0	0	1	RW

Transfers the parameters currently stored in the AFE and saves them in the keypad memory.

Menu	PAR	Description	UM	Type	FB BIT	Def	Min	Max	Acc
4.19	592	Load par from keypad		BIT		0	0	1	RWZ

Transfers the parameters from the keypad memory to the AFE.

Menu	PAR	Description	UM	Type	FB BIT	Def	Min	Max	Acc
4.20	594	Keypad memory select		UINT16		1	1	5	ERW

Selection of the area of the keypad memory to which to transfer and save the parameters stored in the AFE.

5 - REFERENCE

AFE have a DC-link voltage regulation circuit; which can be adapted to suit the various applications. In the standard version, the regulator has PI behaviour and the regulator parameters are the same for the entire field of regulation.

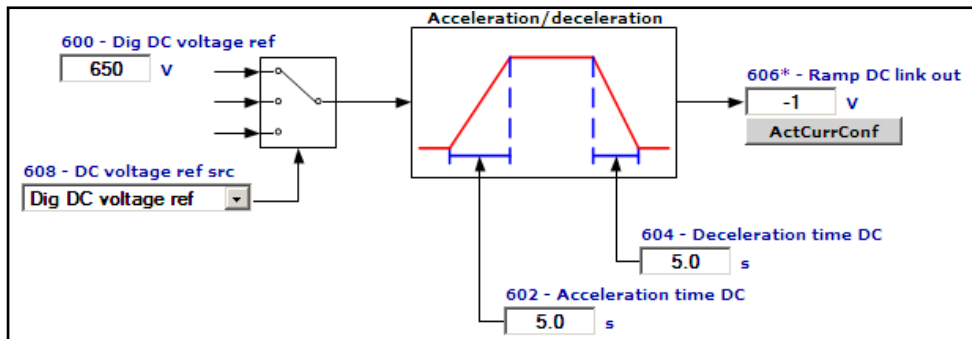

Menu	PAR	Description	UM	Type	FB BIT	Def	Min	Max	Acc
5.1	600	Dig DC voltage ref	V	FLOAT		CALCF	CALCF	CALCF	RW

Setting of the digital reference for the DC-link voltage ramp. This reference sets the ramp voltage that the DC-link must reach after the acceleration phase. Variations in the ramp reference are made with the selected ramp times.

Menu	PAR	Description	UM	Type	FB BIT	Def	Min	Max	Acc
5.2	288	Reactive current ref	A	FLOAT		0.0	0.0	CALCF	RW

Setting of the reference value for the reactive current to be supplied by the AFE200 to the mains.

Menu	PAR	Description	UM	Type	FB BIT	Def	Min	Max	Acc
5.3	602	Acceleration time DC	s	FLOAT		5.0	0.0	20.0	RW
5.4	604	Deceleration time DC	s	FLOAT		5.0	0.0	20.0	RW

The acceleration and deceleration ramp times are used to avoid sudden changes in the DC bus voltage. The acceleration time is expressed as the time needed to increase the voltage from zero to the maximum value (AFE200-4 = 875 V, AFE200-6 = 1300V). The deceleration time is expressed as the time needed to reduce the frequency from the maximum value to zero.

Menu	PAR	Description	UM	Type	FB BIT	Def	Min	Max	Acc
5.5	608	DC voltage ref src		LINK	16	600	0	16384	RW

L_VREF

Selection of the origin (source) of the DC voltage reference signal. The signal used for this function can be set from among those available in the "L_VREF" selection list.

6 - COMMANDS

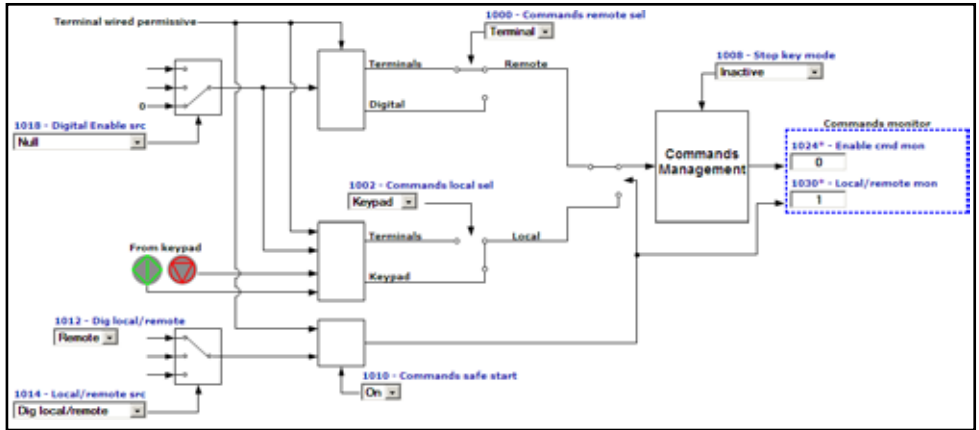

It is possible to work in **Local** or **Remote** mode.

When switching between **Remote** and **Local** modes the origin of the **Enable** and **Start** commands is switched.

In **Remote** mode the “**Commands remote sel**” parameter is used to configure the source of the **Enable** and **Start** commands which can be **Terminal** (standard digital input, expansion digital input) or **Digital** (Modbus, Fieldbus).

In **Local** mode the PAR1002 “**Commands local sel**” parameter is used to configure the source of the **Enable** and **Start** commands, which can be **Terminal** (standard digital input, expansion digital input) or **Keypad** (Start key, Stop key).

In **Remote** -> **Digital** mode the **PAR 1018 Digital Enable src** must be used to configure the source.

Normally the sources are the **Pad** parameters. Modbus or Fieldbus must therefore write the desired value on the **Pad** parameters. Alternatively, the value of 6000 can be written directly on the **Digital Enable src** parameter for a source of **Null** (0) or the value of 6002 for a source of **One** (1).

Another alternative is to configure the **Digital Enable src** source on the **PAR 4454 ... 4484 BitX decomp mon** parameters, so that the Modbus or Fieldbus can then write the desired value on the **PAR 4450 Dig word decomp** parameter.

Local < > **Remote** switching is performed with the variable value configured as **Loc/Remote src**, i.e. it can be a standard digital input, expansion digital input, Modbus, Fieldbus, Dig Local/Remote.

In the default condition, the associated variable is **Dig Local/Remote**, which is written by the **LOC** key from the keypad: switching is thus performed by pressing the **LOC** key.

For safety reasons, **Local** < > **Remote** switching is only performed with Terminal Enable = 0.

Example 1

With the machine in automatic operating mode, the AFE works in Remote -> Digital -> Fieldbus mode. With the machine in manual operating mode, the AFE works in Local -> Terminal -> Standard digital input mode.

If switching from automatic to manual machine operation, the AFE must switch between Remote and Local mode. The switch command must be sent via standard digital input or fieldbus.

Example 2

With the machine controlled from console A, the AFE operates in Local -> Terminal -> Standard digital input mode.

With the machine controlled from console B, the AFE operates in Remote -> Digital -> Expansion digital input mode.

When switching the control console, the AFE must switch between Remote and Local mode. The switch command must be sent via Standard digital input or Expansion digital input.

This configuration is allowed because the Terminal variables are available in the digital command selection lists.

Menu	PAR	Description	UM	Type	FB BIT	Def	Min	Max	Acc
6.1	1000	Commands remote sel		ENUM		Terminal	0	1	RWZ

This parameter defines the source of the command signals when the AFE is used in the **Remote** mode.

The **Enable** command can only be set via hardware, connecting a positive voltage (+24VDC) to terminal 7.

- 0 Terminal
- 1 Digital

When the parameter is set to **Terminals** the source of the **Enable cmd mon** command is the **Enable** terminal (7)

When the parameter is set to **Digital** the origin of the **Enable cmd mon** command is configured using the **PAR 1018 Digital Enable src** parameter.

If **Digital** is set to generate the **Enable cmd mon** command, as well as the variable associated with **Digital Enable src**, the enable hardware command must also be sent to the **Enable** terminal.

Menu	PAR	Description	UM	Type	FB BIT	Def	Min	Max	Acc
6.2	1002	Commands local sel		ENUM		Keypad	0	1	ERWZ

This parameter defines the source of the command signals when the AFE is used in the **Local** mode.

- 0 Terminal
- 2 Keypad

When the parameter is set to **Terminal** the source of the **Enable cmd mon** command is the **Enable** terminal (7) and the origin of the **Start cmd mon** command is configured using the **Terminal Start src** parameter.

When the parameter is set to **Keypad** the origin of the **Enable cmd mon** is the Start key. When Keypad is set to generate the **Enable cmd mon** command, as well as the **Start** key the enable hardware command must also be sent to the **Enable** terminal (7)

Menu	PAR	Description	UM	Type	FB BIT	Def	Min	Max	Acc
6.3	1008	Stop key mode		ENUM		Inactive	0	1	ERW

Setting of the **Stop** key functioning on the keypad. In Local with command from Keypad, this configuration is ineffective.

Active in remote control mode (PAR 1012=1) both by using "Terminals" command or "**Digital**" commands and, in local control mode (PAR 1012=0) by using "Terminals" command

- 0 Inactive
- 1 EmgStop&Alarm

If the command is set to Inactive, pressing the **Stop** key on the keypad is ineffective. If the command is set to **EmgStop&Alarm**, when the **Stop** key is pressed the motor stops in **FastStop mode** and the **Emg stop alarm** is generated. When the motor reaches the speed=0, the drive is automatically disabled and waits for the **Fault reset** command. The **Fault reset** command must be sent twice to reset the drive.

Menu	PAR	Description	UM	Type	FB BIT	Def	Min	Max	Acc
6.4	1010	Commands safe start		BIT		1	0	1	ERW

This parameter is used to define whether the safe start command is disabled or enabled at AFE power-on

- 0 Off
- 1 On

If set to **Off** the safe start function is disabled. Therefore, if the AFE is powered with the hardware signal present on terminal 7 the AFE could start. If set to **On** the safe start function is enabled. Therefore, if the AFE is powered with the hardware enabling signal on terminal 7 it will not start. Open the hardware enabling contact on terminal 7 and then close it again to enable the AFE to accept subsequent commands.

Menu	PAR	Description	UM	Type	FB BIT	Def	Min	Max	Acc
6.5	1012	Dig local/remote		ENUM	16	Remote	0	1	ERW

Setting **Local** or **Remote** operating mode.

- 0 Local
- 1 Remote

Writing this parameter is only effective if it is associated with **Local/Remote src** and if performed without the hardware enabled on the terminal 7. Press **LOC** to modify the value of this parameter 0 < > 1.

To disable the **LOC** key, set **Local/Remote src** to a value other than **Dig local/remote**.

In **Remote** mode use the **Commands remote sel** parameter, PAR 1000 to configure the source of the enable and run commands, which can be **Terminal** board (Standard digital input, Expansion card digital input), or Digital (Modbus, Fieldbus).

In **Local** mode use the **Commands local sel** parameter, PAR 1002 to configure the source of the enable commands, which can be **Terminal** board (Standard digital input, Expansion card digital input), or Keypad (**Start** key, **Stop** key).

Menu	PAR	Description	UM	Type	FB BIT	Def	Min	Max	Acc
6.6	1014	Local/remote src		LINK	16	1012	0	16384	ERW
				L_DIGSEL3					

Selection of the origin (source) of the signal that switches between **Remote** and **Local**.

The signal to be associated with this function can be selected from the "L_DIGSEL3" selection list.

Menu	PAR	Description	UM	Type	FB BIT	Def	Min	Max	Acc
6.7	1018	Digital Enable src		LINK	16	6000	0	16384	ERW
				L_DIGSEL2					

Selection of the origin (source) for the Digital Enable signal. The signal to be associated with this function can be selected from the “L_DIGSEL2” selection list.

Menu	PAR	Description	UM	Type	FB BIT	Def	Min	Max	Acc
6.8	1024	Enable cmd mon		BIT	16	0	0	1	R

The status of the enable command is displayed.

7 - DIGITAL INPUTS

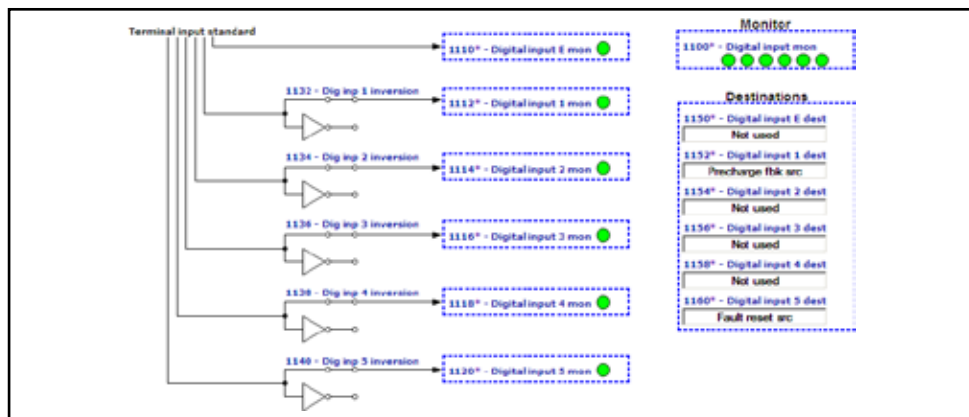

Menu	PAR	Description	UM	Type	FB BIT	Def	Min	Max	Acc
7.1	1132	Dig inp 1 inversion		BIT		0	0	1	RW
7.2	1134	Dig inp 2 inversion		BIT		0	0	1	RW
7.3	1136	Dig inp 3 inversion		BIT		0	0	1	RW
7.4	1138	Dig inp 4 inversion		BIT		0	0	1	RW
7.5	1140	Dig inp 5 inversion		BIT		0	0	1	RW

Reversal of the logic status of the function associated with the digital input (e.g. from enabled with +24V signal to enabled with low signal).

Menu	PAR	Description	UM	Type	FB BIT	Def	Min	Max	Acc
7.6	1150	Digital input E dest		ILINK		0	0	0	ER
7.7	1152	Digital input 1 dest		ILINK		0	0	0	ER
7.8	1154	Digital input 2 dest		ILINK		0	0	0	ER
7.9	1156	Digital input 3 dest		ILINK		0	0	0	ER
7.10	1158	Digital input 4 dest		ILINK		0	0	0	ER
7.11	1160	Digital input 5 dest		ILINK		0	0	0	ER

The function to which the associated digital input refers is displayed.

Menu	PAR	Description	UM	Type	FB BIT	Def	Min	Max	Acc
7.12	1240	Dig inp 1X inversion		BIT		0	0	1	RW
7.13	1242	Dig inp 2X inversion		BIT		0	0	1	RW
7.14	1244	Dig inp 3X inversion		BIT		0	0	1	RW
7.15	1246	Dig inp 4X inversion		BIT		0	0	1	RW
7.16	1248	Dig inp 5X inversion		BIT		0	0	1	RW
7.17	1250	Dig inp 6X inversion		BIT		0	0	1	RW
7.18	1252	Dig inp 7X inversion		BIT		0	0	1	RW
7.19	1254	Dig inp 8X inversion		BIT		0	0	1	RW
7.20	5540	Dig inp 9X inversion		BIT		0	0	1	ERW
7.21	5542	Dig inp10X inversion		BIT		0	0	1	ERW
7.22	5544	Dig inp11X inversion		BIT		0	0	1	ERW
7.23	5546	Dig inp12X inversion		BIT		0	0	1	ERW
7.24	5548	Dig inp13X inversion		BIT		0	0	1	ERW
7.25	5550	Dig inp14X inversion		BIT		0	0	1	ERW
7.26	5552	Dig inp15X inversion		BIT		0	0	1	ERW
7.27	5554	Dig inp16X inversion		BIT		0	0	1	ERW

Reversal of the logic status of the function associated with the digital input of the expansion card.

Menu	PAR	Description	UM	Type	FB BIT	Def	Min	Max	Acc
7.28	1270	Dig input 1X dest		ILINK		0	0	0	ER
7.29	1272	Dig input 2X dest		ILINK		0	0	0	ER
7.30	1274	Dig input 3X dest		ILINK		0	0	0	ER
7.31	1276	Dig input 4X dest		ILINK		0	0	0	ER
7.32	1278	Dig input 5X dest		ILINK		0	0	0	ER
7.33	1280	Dig input 6X dest		ILINK		0	0	0	ER
7.34	1282	Dig input 7X dest		ILINK		0	0	0	ER
7.35	1284	Dig input 8X dest		ILINK		0	0	0	ER
7.36	5570	Dig input 9X dest		ILINK		0	0	0	ER
7.37	5572	Dig input10X dest		ILINK		0	0	0	ER
7.38	5574	Dig input11X dest		ILINK		0	0	0	ER
7.39	5576	Dig input12X dest		ILINK		0	0	0	ER
7.40	5578	Dig input13X dest		ILINK		0	0	0	ER
7.41	5580	Dig input14X dest		ILINK		0	0	0	ER

7.42	5582	Dig input15X dest	ILINK	0	0	0	ER
7.43	5584	Dig input16X dest	ILINK	0	0	0	ER

Selection of the destination of the associated digital input of the expansion card.

8 - DIGITAL OUTPUTS

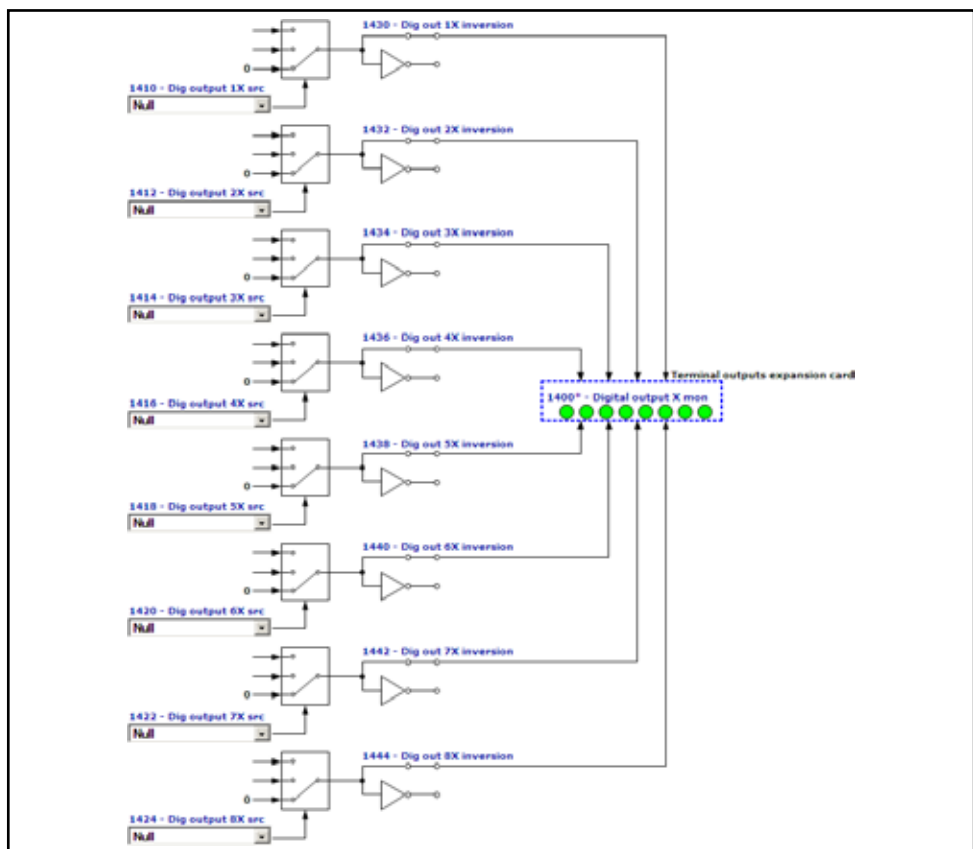
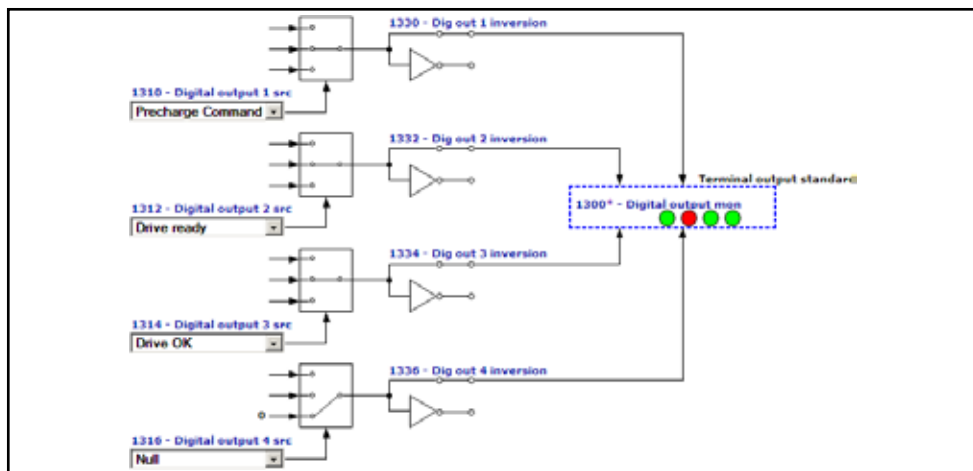

Menu	PAR	Description	UM	Type	FB BIT	Def	Min	Max	Acc
8.1	1310	Digital output 1 src		LINK	16	1122	0	16384	RW
8.2	1312	Digital output 2 src		LINK	16	1064	0	16384	RW
8.3	1314	Digital output 3 src		LINK	16	1062	0	16384	RW
8.4	1316	Digital output 4 src		LINK	16	6000	0	16384	RW

L_DIGSEL1

Selection of the origin (source) of the signal to be assigned to the relative digital output. The functions that can be associated with the digital outputs are listed in the "L_DIGSEL1" selection list.

Menu	PAR	Description	UM	Type	FB BIT	Def	Min	Max	Acc
8.5	1330	Dig out 1 inversion		BIT		0	0	1	RW
8.6	1332	Dig out 2 inversion		BIT		0	0	1	RW
8.7	1334	Dig out 3 inversion		BIT		0	0	1	RW
8.8	1336	Dig out 4 inversion		BIT		0	0	1	RW

Reversal of the logic status of the function associated with the digital output.

Menu	PAR	Description	UM	Type	FB BIT	Def	Min	Max	Acc
8.9	1410	Dig output 1X src		LINK	16	6000	0	16384	RW
8.10	1412	Dig output 2X src		LINK	16	6000	0	16384	RW
8.11	1414	Dig output 3X src		LINK	16	6000	0	16384	RW
8.12	1416	Dig output 4X src		LINK	16	6000	0	16384	RW
8.13	1418	Dig output 5X src		LINK	16	6000	0	16384	RW
8.14	1420	Dig output 6X src		LINK	16	6000	0	16384	RW
8.15	1422	Dig output 7X src		LINK	16	6000	0	16384	RW
8.16	1424	Dig output 8X src		LINK	16	6000	0	16384	RW

L_DIGSEL1

Selection of the origin (source) of the signal to be assigned to the relative digital output of the expansion card. The functions that can be associated with the digital outputs are listed in the "L_DIGSEL1" selection list.

Menu	PAR	Description	UM	Type	FB BIT	Def	Min	Max	Acc
8.17	1430	Dig out 1X inversion		BIT		0	0	1	RW
8.18	1432	Dig out 2X inversion		BIT		0	0	1	RW
8.19	1434	Dig out 3X inversion		BIT		0	0	1	RW
8.20	1436	Dig out 4X inversion		BIT		0	0	1	RW
8.21	1438	Dig out 5X inversion		BIT		0	0	1	RW
8.22	1440	Dig out 6X inversion		BIT		0	0	1	RW
8.23	1442	Dig out 7X inversion		BIT		0	0	1	RW
8.24	1444	Dig out 8X inversion		BIT		0	0	1	RW

Reversal of the logic status of the function associated with the digital output of the expansion card.

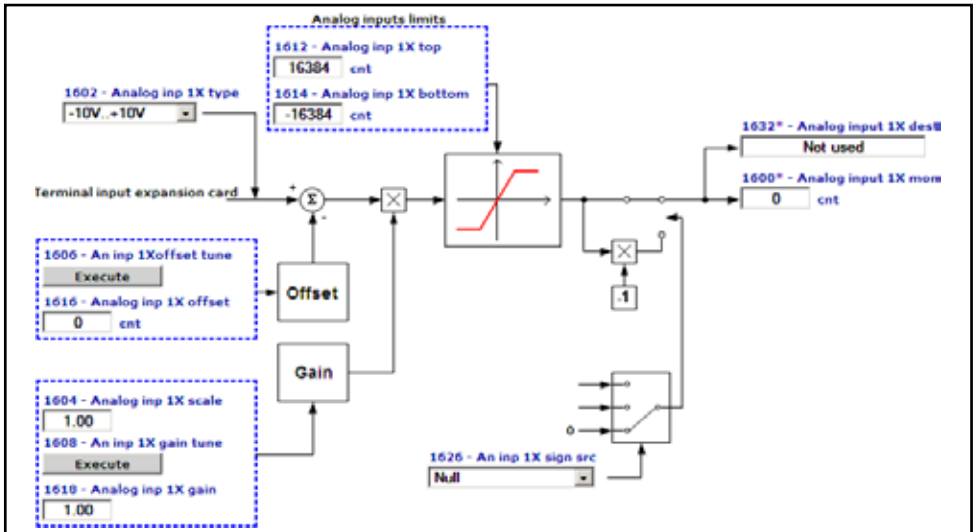
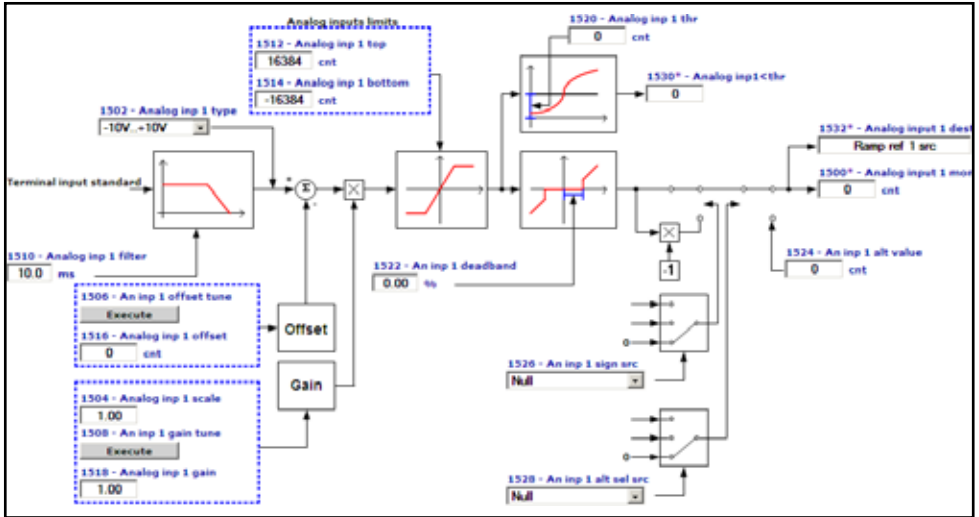

Menu	PAR	Description	UM	Type	FB BIT	Def	Min	Max	Acc
9.1	1500	Analog input 1 mon	cnt	INT16	16/32	0	0	0	R
9.17	1550	Analog input 2 mon	cnt	INT16	16/32	0	0	0	R

The value of the voltage on the output of the function block of the relative analog input is displayed.

Menu	PAR	Description	UM	Type	FB BIT	Def	Min	Max	Acc
9.2	1502	Analog inp 1 type		ENUM		-10V..+10V	0	2	RW

9.18 1552 Analog inp 2 type ENUM -10V..+10V 0 2 RW
 Selection of the type of input (voltage or current). Depending on the input signal, move the switches on the regulation card. The factory parameter is inputs set for differential voltage signals ($\pm 10V$).

0 -10V..+10V
 1 0.20mA ... 0.10V
 2 4..20mA

Select option **0** in order to connect a maximum voltage of $\pm 12.5V$ (typically $\pm 10V/5mA$) to the analog input concerned. If the signal is used as a reference, reverse the direction of rotation by inverting the voltage polarity.

Select option **1** to connect a max voltage of 12.5V (typically 10V/5mA) or a signal in current from 0 ... 20 mA to the analog input concerned. The signal must be positive.

Select option **2** to connect a current signal of 4...20 mA to the analog input concerned. The signal must be positive.

Menu	PAR	Description	UM	Type	FB BIT	Def	Min	Max	Acc
9.3	1504	Analog inp 1 scale		FLOAT		1.0	-10.0	10.0	RW
9.19	1554	Analog inp 2 scale		FLOAT		1.0	-10.0	10.0	RW

Setting of a multiplier factor to apply to the relative analog input.

Example :

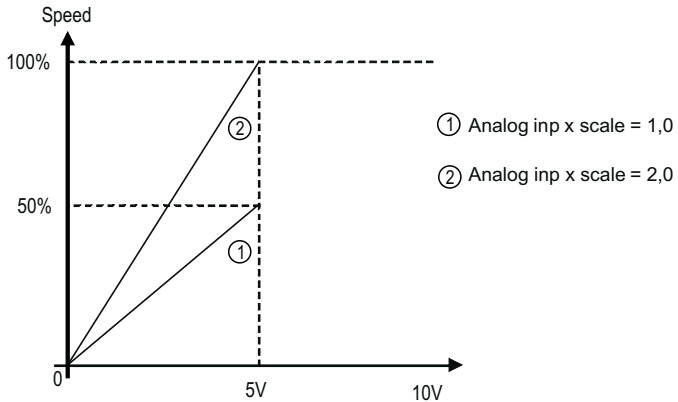

The speed reference of a AFE is assigned with a max external voltage of 5V. As the **Analog inp x scale** parameter a scale factor of 2 is entered (10V : 5V).

Menu	PAR	Description	UM	Type	FB BIT	Def	Min	Max	Acc
9.4	1506	An inp 1 offset tune		BIT		0	0	1	ERW
9.20	1556	An inp 2 offset tune		BIT		0	0	1	ERW

Self-tuning command for the relative analog input offset. Automatic fine tuning of the input. To perform self-tuning, set the input signal to its minimum value and execute the command. The conditions containing an offset can be compensated. When this

command is sent, An inp x offset tune is automatically selected so that the available input signal corresponds to the zero value of the variable. Offset tuning can also be performed with the AFE enabled. Automatic tuning can only be performed if the following condition is present:

Automatic tuning can only be performed if the following condition is present:

- Input voltage less than 1V or input current less than 2 mA

Note!

The value that is obtained automatically can be changed manually if necessary, using **Analog inp x offset**.

If the voltage setting on the analog input is higher than 1V, the **Value too low** alarm is generated.

Menu	PAR	Description	UM	Type	FB BIT	Def	Min	Max	Acc
9.5	1508	An inp 1 gain tune		BIT		0	0	1	RWZ
9.21	1558	An inp 2 gain tune		BIT		0	0	1	RWZ

Self-tuning command for the relative analog input gain. Automatic fine tuning of the input. When this command is sent, Analog inp 1 gain x is automatically selected so that the available input signal corresponds to the maximum value of the variable. Offset tuning can also be performed with the AFE enabled.

Two conditions are necessary in order to perform automatic tuning:

- Input voltage greater than 1V or input current greater than 2 mA
- Positive polarity. The value found is automatically accepted even for negative polarity.

Note!

If necessary, the value obtained automatically can be changed manually via **Analog inp x gain**.

To perform self-tuning, set the input signal to its maximum value and execute the command. A multiplier factor is calculated to apply to the input signal value (not considering the Analog inp scale parameter) to reach the **full scale value**.

If the voltage setting on the analog input is less than 1V, the **Value too low** alarm is generated.

Menu	PAR	Description	UM	Type	FB BIT	Def	Min	Max	Acc
9.6	1510	Analog inp 1 filter	ms	FLOAT		10.0	1.0	100.0	ERW
9.22	1560	Analog inp 2 filter	ms	FLOAT		10.0	1.0	100.0	ERW

Filter on the measurement of the corresponding analog input. This parameter can be used to control the response of the analog input and reduce any possible noise and interference.

Menu	PAR	Description	UM	Type	FB BIT	Def	Min	Max	Acc
9.7	1512	Analog inp 1 top	cnt	INT16		16384	-32768	+32767	ERW
9.23	1562	Analog inp 2 top	cnt	INT16		16384	-32768	+32767	ERW

Setting of the upper speed reference limit as a function of the voltage (or current) of the relative analog reference.

Menu	PAR	Description	UM	Type	FB BIT	Def	Min	Max	Acc
9.8	1514	Analog inp 1 bottom	cnt	INT16		-16384	-32768	+32767	ERW
9.24	1564	Analog inp 2 bottom	cnt	INT16		-16384	-32768	+32767	ERW

Setting of the lower speed reference limit as a function of the voltage (or current) of the relative analog reference..

Menu	PAR	Description	UM	Type	FB BIT	Def	Min	Max	Acc
9.9	1516	Analog inp 1 offset	cnt	INT16		0	-32768	+32767	ERW
9.25	1566	Analog inp 2 offset	cnt	INT16		0	-32768	+32767	ERW

Setting of a value to compensate the condition in which the analog signal contains an offset, or when the variable assigned to the input already has a value even though no signal is connected.

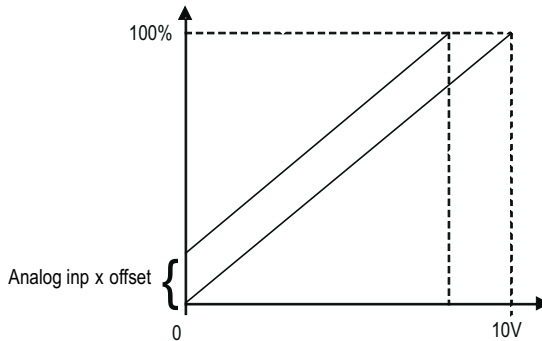

Menu	PAR	Description	UM	Type	FB BIT	Def	Min	Max	Acc
9.10	1518	Analog inp 1 gain		FLOAT		1.0	-10.0	10.0	ERW
9.26	1568	Analog inp 2 gain		FLOAT		1.0	-10.0	10.0	ERW

This parameter contains the value of the multiplier factor to apply to the analog reference calculated using the **Analog inp gain tune** function.

Example :

An external analog reference only reaches a maximum of 9.8V instead of 10V. 1.020 (10V : 9.8V) is entered as the **Analog inp x gain** parameter.

The same result can be achieved using the **An inp x gain tune** function. This parameter can be selected from the keypad menu. The maximum analog value available (in this case 9.8V) must be present on the terminal, with positive polarity. Press the **Enter** key on the keypad to start analog reference self-tuning.

Menu	PAR	Description	UM	Type	FB BIT	Def	Min	Max	Acc
9.11	1520	Analog inp 1 thr		INT16		0	-16384	+16383	ERW
9.27	1570	Analog inp 2 thr		INT16		0	-16384	+16383	ERW

Setting of the analog input threshold for the speed not exceeded signal, which allows enabling of the digital outputs **Analog inp1<thr** (PAR 1530) and **Analog inp2<thr** (PAR 1580).

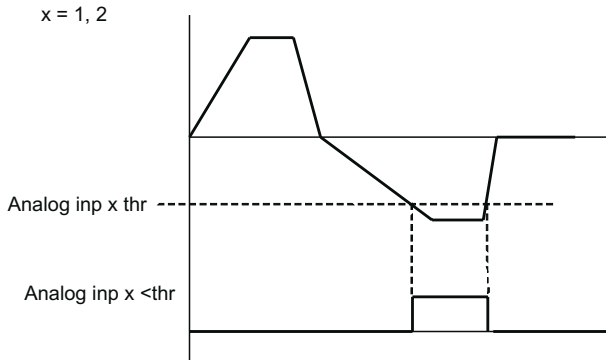
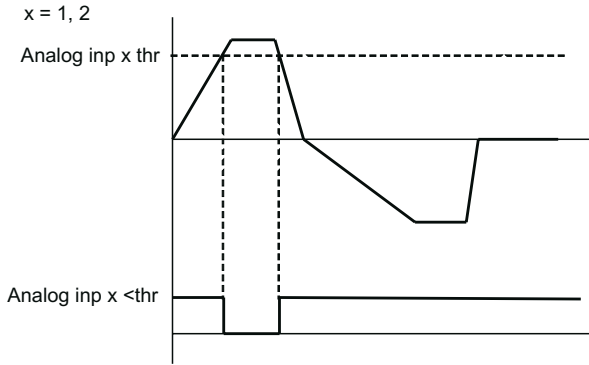

Menu	PAR	Description	UM	Type	FB BIT	Def	Min	Max	Acc
9.12	1522	An inp 1 deadband	perc	FLOAT		0.0	0.0	100.0	ERW
9.28	1572	An inp 2 deadband	perc	FLOAT		0.0	0.0	100.0	ERW

Deadband referring to the analog input signal. When the value on the input terminal is below the threshold defined by the parameter, the output signal of the analog input block is forced to zero. Outside the deadband, the block output varies linearly from zero to 100%.

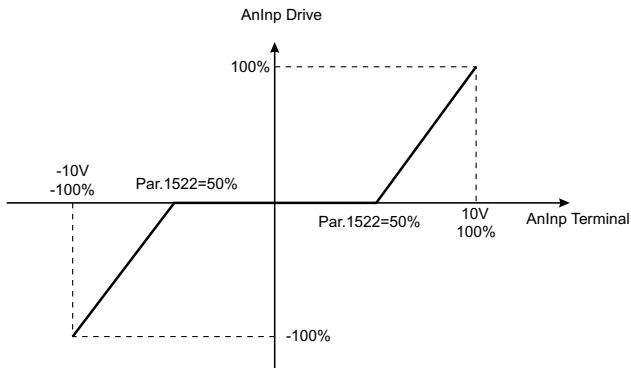

Menu	PAR	Description	UM	Type	FB BIT	Def	Min	Max	Acc
9.13	1524	An inp 1 alt value	cnt	INT16	16/32	0	-16384	16384	ERW
9.29	1574	An inp 2 alt value	cnt	INT16	16/32	0	-16384	16384	ERW

Setting of a fixed alternative value for the relative analog input, which can be selected via a command enabled by a digital input programmed with the **An inp alt sel src** parameter.

Menu	PAR	Description	UM	Type	FB BIT	Def	Min	Max	Acc
9.14	1526	An inp 1 sign src		LINK	16	6000	0	16384	ERW
9.30	1576	An inp 2 sign src		LINK	16	6000	0	16384	ERW

L_DIGSEL2

Selection of the origin (source) of the signal to be assigned to the relative digital input for selecting the direction of rotation of the motor. The functions that can be associated with the digital outputs are listed in the "L_DIGSEL2" selection list.

Menu	PAR	Description	UM	Type	FB BIT	Def	Min	Max	Acc
9.15	1528	An inp 1 alt sel src		LINK	16	6000	0	16384	ERW
9.31	1578	An inp 2 alt sel src		LINK	16	6000	0	16384	ERW

L_DIGSEL2

Selection of the origin (source) of the signal to be assigned to the relative digital input for selecting the alternative analog reference. The functions that can be associated with the digital outputs are listed in the "L_DIGSEL2" selection list.

Menu	PAR	Description	UM	Type	FB BIT	Def	Min	Max	Acc
9.16	1532	Analog input 1 dest		ILINK		0	0	0	ER
9.32	1582	Analog input 2 dest		ILINK		0	0	0	ER

The function for which the relative analog input has been programmed and on which it acts is displayed.

Menu	PAR	Description	UM	Type	FB BIT	Def	Min	Max	Acc
9.33	1600	Analog input 1X mon	cnt	INT16	16/32	0	0	0	R
9.44	1650	Analog input 2X mon	cnt	INT16	16/32	0	0	0	R

The value of the voltage output of the function block of the relative analog input is displayed.

Menu	PAR	Description	UM	Type	FB BIT	Def	Min	Max	Acc
9.34	1602	Analog inp 1X type		ENUM		-10V..+10V	0	2	RW
9.45	1652	Analog inp 2X type		ENUM		-10V..+10V	0	2	RW

Selection of the type of expansion card input (voltage or current input). Depending on the input signal, move the switches on the regulation card. Standard inputs are coded for voltage signals.

- 0** -10V..+10V
- 1** 0.20mA ... 0.10V
- 2** 4..20mA

Select option **0** in order to connect a maximum voltage of $\pm 12.5V$ (typically $\pm 10V/5mA$) to the analog input concerned. If the signal is used as a reference, reverse the direction of rotation of the drive by inverting the voltage polarity.

Select option **1** to connect a max voltage of 12.5V (typically 10V/5mA) or a signal in current from 0 ... 20 mA to the analog input concerned. The signal must be positive.

Select option **2** to connect a current signal of 4...20 mA to the analog input concerned. The signal must be positive.

Menu	PAR	Description	UM	Type	FB BIT	Def	Min	Max	Acc
9.35	1604	Analog inp 1X scale		FLOAT		1.0	-20.0	20.0	RW
9.46	1654	Analog inp 2X scale		FLOAT		1.0	-20.0	20.0	RW

Setting of a multiplier factor to apply to the relative analog input of the expansion card.

Example :

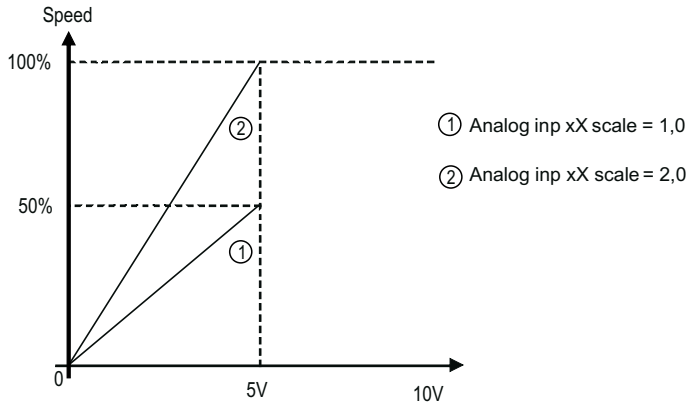

The speed reference of a drive is assigned with a max external voltage of 5V. As the Analog inp X scale parameter the scale factor of 2 is entered (10V : 5V).

Menu	PAR	Description	UM	Type	FB BIT	Def	Min	Max	Acc
9.36	1606	An inp 1Xoffset tune		BIT		0	0	1	RWZ

9.47	1656	An inp 2Xoffset tune	BIT	0	0	1	RWZ
------	------	----------------------	-----	---	---	---	-----

Self-tuning command for the offset of the relative analog input of the expansion card. Automatic fine tuning of the input. To perform self-tuning, set the input signal to its minimum value and execute the command. The conditions containing an offset can be compensated. When this command is sent, **An inp xX offset** tune is automatically selected so that the available input signal corresponds to the zero value of the variable.

Automatic tuning can only be performed if the following condition is present:
 - Input voltage less than 1V or input current less than 2 mA

Note!

.....
 The value that is obtained automatically can be changed manually, if necessary, using **An inp offset xX**.

If the voltage setting on the analog input is higher than 1V, the **Value too low** alarm is generated.

Menu	PAR	Description	UM	Type	FB BIT	Def	Min	Max	Acc
9.37	1608	An inp 1X gain tune		BIT		0	0	1	RWZ
9.48	1658	An inp 2X gain tune		BIT		0	0	1	RWZ

Self-tuning command for the relative analog input gain. Automatic fine tuning of the input. When this command is sent, **Analog inp 1 gain x** is automatically selected so that the available input signal corresponds to the maximum value of the variable.

Two conditions are necessary in order to perform automatic tuning:

- Input voltage greater than 1V or input current greater than 2 mA
- Positive polarity. The value found is automatically accepted even for negative polarity.

Note!

.....
 If necessary, the value obtained automatically can be changed manually via **Analog inp Xx gain**.

To perform self-tuning, set the input signal to its maximum value and execute the command. A multiplier factor is calculated to apply to the input signal value (not considering the Analog inp scale parameter) to reach the full scale value.

If the voltage setting on the analog input is less than 1V, the **Value too low** alarm is generated.

Menu	PAR	Description	UM	Type	FB BIT	Def	Min	Max	Acc
9.38	1612	Analog inp 1X top	cnt	INT16		16384	-32768	+32767	ERW
9.49	1662	Analog inp 2X top	cnt	INT16		16384	-32768	+32767	ERW

Setting of the upper speed reference limit as a function of the voltage (or current) of the relative analog reference of the expansion card.

Menu	PAR	Description	UM	Type	FB BIT	Def	Min	Max	Acc
9.39	1614	Analog inp 1X bottom	cnt	INT16		-16384	-32768	+32767	ERW
9.50	1664	Analog inp 2X bottom	cnt	INT16		-16384	-32768	+32767	ERW

Setting of an offset value to algebraically add to the relative analog input of the expansion card.

Menu	PAR	Description	UM	Type	FB BIT	Def	Min	Max	Acc
9.40	1616	Analog inp 1X offset	cnt	INT16		0	-32768	+32767	ERW
9.51	1666	Analog inp 2X offset	cnt	INT16		0	-32768	+32767	ERW

Setting of an offset value to algebraically add to the relative analog input of the expansion card.

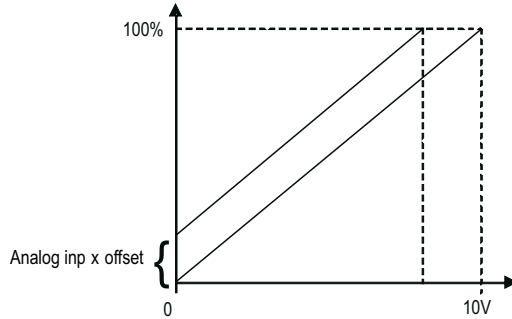

Menu	PAR	Description	UM	Type	FB BIT	Def	Min	Max	Acc
9.41	1618	Analog inp 1X gain		FLOAT		1.0	-20.0	20.0	ERW
9.52	1668	Analog inp 2X gain		FLOAT		1.0	-20.0	20.0	ERW

This parameter contains the value of the multiplier factor to apply to the analog reference of the expansion card calculated using the **Analog inp gain tune** function.

Example :

An external analog reference only reaches a maximum of 9.8V instead of 10V. 1.020 (10V : 9.8V) is entered as the **Analog inp x gain** parameter.

The same result can be achieved using the **Analog inp x gain** tune function. This parameter can be selected from the keypad menu. The maximum analog value available (in this case 9.8V) must be present on the terminal, with positive polarity. Press the **Enter** key on the keypad to start analog reference self-tuning.

Menu	PAR	Description	UM	Type	FB BIT	Def	Min	Max	Acc
9.42	1626	An inp 1X sign src		LINK	16	6000	0	16384	ERW
9.53	1676	An inp 2X sign src		LINK	16	6000	0	16384	ERW

L_DIGSEL2

Selection of the origin (source) for the signal to be assigned to the relative digital input for selecting the sign of the relative analog reference signal. The functions that can be associated with the digital outputs are listed in the "L_DIGSEL2" selection list.

Menu	PAR	Description	UM	Type	FB BIT	Def	Min	Max	Acc
9.43	1632	Analog inp 1X dest		ILINK		0	0	0	ER
9.54	1682	Analog inp 2X dest		ILINK		0	0	0	ER

The function for which the relative analog input of the expansion card has been programmed and on which it acts is displayed.

Menu	PAR	Description	UM	Type	FB BIT	Def	Min	Max	Acc
9.55	5410	Analog inp 0Ext mon		INT16	16BIT	0	-32768	32767	ER
9.56	5412	Analog inp 1Ext mon		INT16	16BIT	0	-32768	32767	ER
9.57	5414	Analog inp 2Ext mon		INT16	16BIT	0	-32768	32767	ER
9.58	5416	Analog inp 3Ext mon		INT16	16BIT	0	-32768	32767	ER
9.59	5418	Analog inp 4Ext mon		INT16	16BIT	0	-32768	32767	ER
9.60	5420	Analog inp 5Ext mon		INT16	16BIT	0	-32768	32767	ER
9.61	5422	Analog inp 6Ext mon		INT16	16BIT	0	-32768	32767	ER
9.62	5424	Analog inp 7Ext mon		INT16	16BIT	0	-32768	32767	ER

These parameters show the value of the analog input of the I/O remotable module (EXP-FL-XCAN-ADV expansion board is needed).

Analog input modules can have a resolution of 12 to 16 bits and scaling may vary from manufacturer to manufacturer.

E.g.:

12-bit module

Signal connected Module configuration	Variant 1	Variant 2	Variant 3	Variant 4
-10V..+10V	-2048..+2047	-32768..+32767	-16384..+16383	
0V..+10V	0..+4095	0..+2047	0..+32767	0..+65535
4..20mA	0..+32767	+6553..+32767	+3276..+16383	

16-bit module

Signal connected Module configuration	Variant 1	Variant 2	Variant 3	
-10V..+10V	-32768..+32767			
0V..+10V	0..+65535	0..+32767		
4..20mA				

There is no single Unit suitable for all models of analog input module. Check the scaling provided by the model being used and use the system variables accordingly.

Analog input 0 and **Analog input 1** can also be managed by the drive parameters.

To ensure correction operation, the scaling provided by the external module must be compatible with the scaling requested by the drive.

The drive needs I/O modules that supply datum scaled as follows:

Analog inp X type	Range
-10V..+10V	-32768..+32767
0V..+10V	0..+65535
4..20mA	+13107..+65535

When the **An inp X gain tune** (PAR 1508, PAR1558) command is sent with analog input set to the maximum value, the gain needed to adjust the full scale value is calculated.

For modules with scaling other than that requested by the drive, the **An inp X gain tune** command attempts to adjust the scaling. For that reason the maximum value is increased for **An inp X gain tune** parameters.

The tables below show the output of the analog input block according to the signal connected and the configuration of the **Analog inp X type** parameter (PAR 1502,

PAR1552).

Signal connected: -10V..+10V

An input type	-10V	0V	+10V
-10V..+10V	Bottom	Obtained from straight line	Top
0V..+10V	Less than 0V saturation at Bottom	Bottom	Top
4.0.20 mA	Less than 2V saturation at Bottom	Bottom	Top

Signal connected: 0V..+10V

An input type		0V	+10V
-10V..+10V		Obtained from straight line	Top
0V..+10V		Bottom	Top
4..20 mA		Less than 2V saturation at Bottom	Top

Signal connected: 4..20 mA

An input type		4mA	20mA
-10V..+10V			Top
0V..+10V		Less than 4 mA saturation at Bottom	Top
4..20 mA		Bottom	Top

The Analog inputs voltage or current inputs must be configured on the external module using a dedicated switch or tool. For analog input 0 and analog input 1 the **An input type** parameter must be set according to the type of external device.

10 - ANALOG OUTPUTS

On the AFE200 regulation card there are two programmable analog outputs.

Analog output 1 supplies a two-pole +/-10VDC voltage signal, while analog output 2 can be programmed to obtain a 0-20mA or 4-20mA output signal in current or a signal in two-pole +/-10VDC voltage, depending on the parameter assigned.

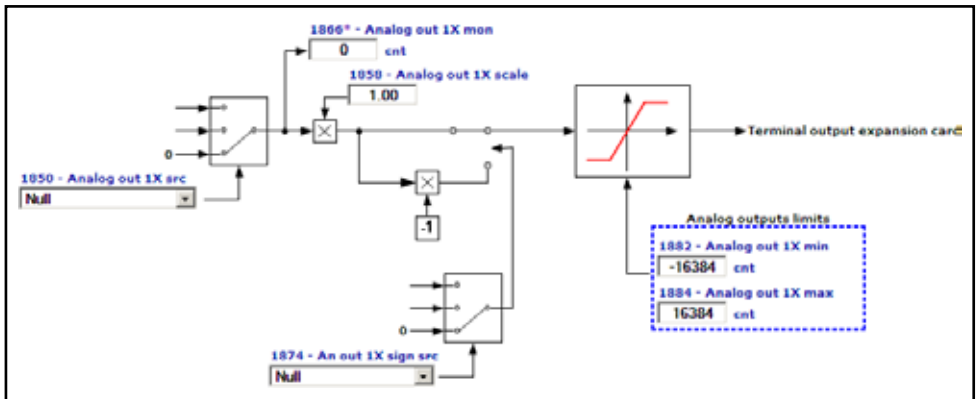
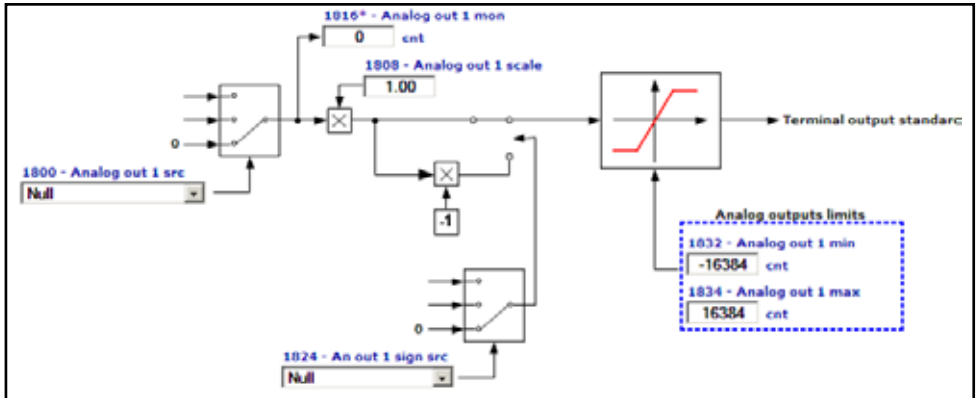

Table: value of the signal of the analog outputs according to the measurement used

PAR	Description	Full scale output
250	Output current	10V = 200% Heavy Duty AFE rated current (this value can be found in the manual and is defined @400Vac, default switching frequency and 40°C)
280	Active current ref	
282	React curr ref mon	
284	Active current	
286	Reactive current	
2388	Active curr noflt	
252	Output voltage	10V = 200% Mains voltage (PAR 560)
254	Output frequency	10V = 1000Hz
270	DC link voltage	10V = 7000V

1500	Analog input 1 mon	10V = 10V Analog input
1550	Analog input 2 mon	
1600	Analog input 1X mon	
1650	Analog input 2X mon	
368	Drive overload accum	5V = 100% Accumulator
4024 ... 4174	Fieldbus M->SX mon	10V = 16384 * 2 ^ 16
3700 ... 3730	Pad X	

Menu	PAR	Description	UM	Type	FB BIT	Def	Min	Max	Acc
10.1	1800	Analog out 1 src		LINK	16/32	6000	0	16384	RW
10.2	1802	Analog out 2 src		LINK	16/32	6000	0	16384	RW

L_ANOUT

Selection of the origin (source) of the signals that can be placed as variables on the analog outputs. The functions that can be assigned to the analog outputs are listed in the "L_ANOUT" selection list.

Menu	PAR	Description	UM	Type	FB BIT	Def	Min	Max	Acc
10.3	1808	Analog out 1 scale		FLOAT		1.0	-10.0	10.0	RW
10.4	1810	Analog out 2 scale		FLOAT		1.0	-10.0	10.0	RW

Parameter for setting a multiplier factor of the signal of the relative analog output. It can be used to amplify or reduce the input value of the relative analog output block.

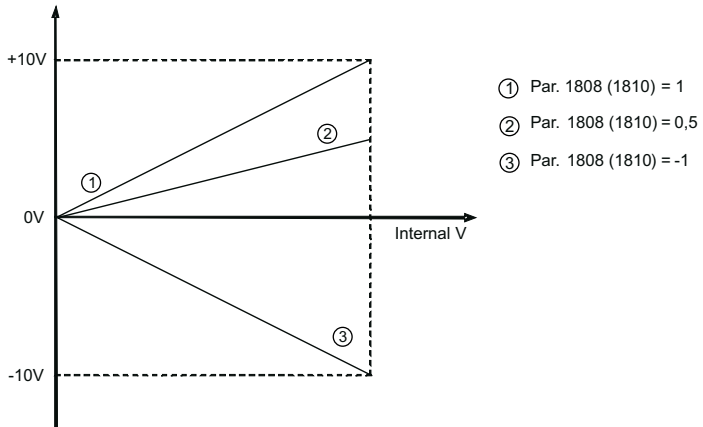

$$V_{out} = 10 \times \left(\frac{\text{Stp Var} \times \text{par. 1808 (1810)}}{\text{FS Var}} \right)$$

where:

Vout output voltage on the card terminals.
Stp Var actual value of the variable (variable unit)
FS Var full scale of the variable (variable unit)

*Example of calculation of scale factor **Analog out x scale** :*

To display the AFE speed, use an analog instrument with field of measurement from 0...2V. This means that, to display the speed of the AFE, a voltage of 2V on the analog output of the AFE must correspond to the maximum speed. With a scale factor of 1 this would be 10V (Scale factor = 2V / 10 V = 0.200).

Menu	PAR	Description	UM	Type	FB BIT	Def	Min	Max	Acc
10.5	1816	Analog out 1 mon	cnt	INT16		0	0	0	ER

The value of the actual voltage present on analog output 1 is displayed.

Menu	PAR	Description	UM	Type	FB BIT	Def	Min	Max	Acc
10.6	1818	Analog out 2 mon	cnt	INT16		0	0	0	ER

The value of the actual voltage or current present on analog output 2 is displayed.

Menu	PAR	Description	UM	Type	FB BIT	Def	Min	Max	Acc
10.7	1824	An out 1 sign src		LINK	16	6000	0	16384	ERW
10.8	1826	An out 2 sign src		LINK	16	6000	0	16384	ERW

L_DIGSEL2

Selection of the origin (source) for the signal that determines the sign of the relative analog output. The terminal to be associated with this function can be selected from the "L_DIGSEL2" selection list.

Menu	PAR	Description	UM	Type	FB BIT	Def	Min	Max	Acc
10.9	1832	Analog out 1 min	cnt	INT16		-16384	-32768	+32767	ERW
10.10	1834	Analog out 1 max	cnt	INT16		16384	-32768	+32767	ERW

Setting of the minimum and maximum values for the analog output for the voltage present on analog output 1.

Menu	PAR	Description	UM	Type	FB BIT	Def	Min	Max	Acc
10.11	1840	Analog out 2 min	cnt	INT16		-16384	-32768	+32767	ERW
10.12	1842	Analog out 2 max	cnt	INT16		16384	-32768	+32767	ERW

Setting of the minimum and maximum values for the analog output for the voltage present on analog output 2.

Menu	PAR	Description	UM	Type	FB BIT	Def	Min	Max	Acc
10.13	1848	Analog out 2 type		ENUM		-10V..+10V	0	2	ERW

Selection of the type of output (in voltage or current). Depending on the output signal, move the switch on the regulation card. The standard output is coded for the signal in voltage.

- 0** 0..20mA
- 1** 4..20mA
- 2** -10V..+10V

Select option **0** in order to apply a maximum voltage of $\pm 12.5V$ (typically $\pm 10V/5mA$) to analog output 2.

Select option **1** in order to apply a maximum voltage of +10V or a signal in current of 0 ... 20 mA to analog output 2. The signal must be positive.

Select option **2** to apply a signal in current of 4...20 mA to analog output 2.

Menu	PAR	Description	UM	Type	FB BIT	Def	Min	Max	Acc
10.14	1850	Analog out 1X src		LINK	16/32	6000	0	16384	RW
10.15	1852	Analog out 2X src		LINK	16/32	6000	0	16384	RW

L_ANOUT

Selection of the origin (source) of the signals that can be placed as variables on the analog outputs of the expansion card. The functions that can be assigned to the analog outputs are listed in the “L_ANOUT” selection list.

Menu	PAR	Description	UM	Type	FB BIT	Def	Min	Max	Acc
10.16	1858	Analog out 1X scale		FLOAT		1.0	-20.0	20.0	RW
10.17	1860	Analog out 2X scale		FLOAT		1.0	-20.0	20.0	RW

Parameter for setting a multiplier factor of the signal of the relative analog output of the expansion card. It can be used to amplify or reduce the input value of the relative analog output block.

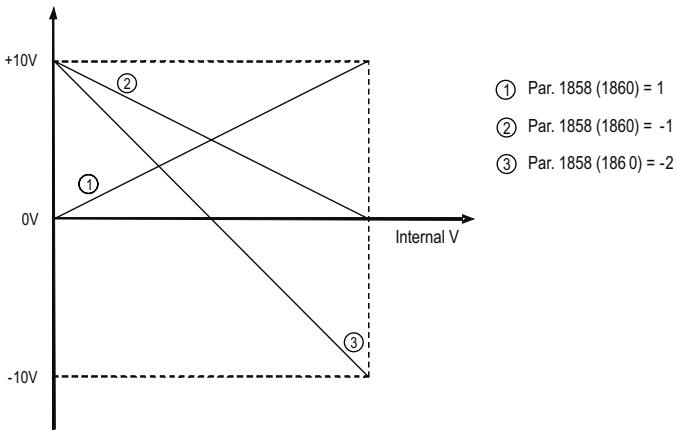

$$V_{out} = 10 \times \left(\frac{\text{Stp Var} \times \text{par. 1858 (1860)}}{\text{FS Var}} \right)$$

where:

- Vout** output voltage on the card terminals.
- Stp Var** actual value of the variable (variable unit)
- FS Var** full scale of the variable (variable unit)

Example of calculation of the Analog out Xx scale factor

To display the AFE speed, use an analog instrument with field of measurement from 0 ... 2V. This means that, to display the speed of the AFE, a voltage of 2V on the analog output of the AFE must correspond to the maximum speed. With a scale factor of 1 this would be 10V (Scale factor = 2V / 10 V = 0.200).

Menu	PAR	Description	UM	Type	FB BIT	Def	Min	Max	Acc
10.18	1866	Analog out 1X mon	cnt	INT16		0	0	0	ER

The actual value of the voltage present on analog output 1 of the expansion card is displayed.

Menu	PAR	Description	UM	Type	FB BIT	Def	Min	Max	Acc
10.19	1868	Analog out 2X mon	cnt	INT16		0	0	0	ER

The actual value of the voltage or current present on analog output 2 of the expansion card is displayed.

Menu	PAR	Description	UM	Type	FB BIT	Def	Min	Max	Acc
10.20	1874	An out 1X sign src		LINK	16	6000	0	16384	ERW
10.21	1876	An out 2X sign src		LINK	16	6000	0	16384	ERW

L_DIGSEL2

Selection of the origin (source) for the signal that determines the polarity of the relative analog output of the expansion card. The terminal to be associated with this function can be selected from the "L_DIGSEL2" selection list.

Menu	PAR	Description	UM	Type	FB BIT	Def	Min	Max	Acc
10.22	1882	Analog out 1X min	cnt	INT16		-16384	-32768	+32767	ERW
10.23	1884	Analog out 1X max	cnt	INT16		16384	-32768	+32767	ERW

Setting of the minimum and maximum values for the analog output for the voltage present on analog output 1 of the expansion card.

Menu	PAR	Description	UM	Type	FB BIT	Def	Min	Max	Acc
10.24	1890	Analog out 2X min	cnt	INT16		-16384	-32768	+32767	ERW
10.25	1892	Analog out 2X max	cnt	INT16		16384	-32768	+32767	ERW

Setting of the minimum and maximum values for the analog output in current or voltage present on analog output 2 of the expansion card.

Menu	PAR	Description	UM	Type	FB BIT	Def	Min	Max	Acc
10.26	1898	Analog out 2X type		ENUM		-10V..+10V	0	2	ERW

Selection of the programmed signal on analog output 2 of the expansion card. Depending on the output signal, move the switch on the regulation card. The standard output is coded for the signal in voltage.

- 0** 0..20mA
- 1** 4..20mA
- 2** -10V..+10V

Select option **0** in order to apply a maximum voltage of $\pm 12.5V$ (typically $\pm 10V/5mA$) to analog output 2.

Select option **1** in order to apply a maximum voltage of +10V or a signal in current of 0 ... 20 mA to analog output 2. The signal must be positive.

Select option **2** to apply a signal in current of 4...20 mA to analog output 2.

Menu	PAR	Description	UM	Type	FB BIT	Def	Min	Max	Acc
10.27	5460	Dig Analog out 0 ext		INT16	16BIT	0	-32768	32767	ERW
10.28	5462	Dig Analog out 1 ext		INT16	16BIT	0	-32768	32767	ERW
10.29	5464	Dig Analog out 2 ext		INT16	16BIT	0	-32768	32767	ERW
10.30	5466	Dig Analog out 3 ext		INT16	16BIT	0	-32768	32767	ERW

10.31	5468	Dig Analog out 4 ext	INT16	16BIT	0	-32768	32767	ERW
10.32	5470	Dig Analog out 5 ext	INT16	16BIT	0	-32768	32767	ERW
10.33	5472	Dig Analog out 6 ext	INT16	16BIT	0	-32768	32767	ERW
10.34	5474	Dig Analog out 7 ext	INT16	16BIT	0	-32768	32767	ERW

These parameters are used with I/O remotable module (EXP-FL-XCAN-ADV expansion board is needed).

Analog output modules can have a resolution of 12 to 16 bits and scaling may vary from manufacturer to manufacturer.

E.g.:

12-bit module

Signal connected Module configuration	Variant 1	Variant 2	Variant 3	Variant 4
-10V..+10V	-2048..+2047	-32768..+32767	-16384..+16383	
0V..+10V	0..+4095	0..+2047	0..+16383	0..+32767
4..20mA	0..+32767	+6553..+32767	+3276..+16383	

16-bit module

Signal connected Module configuration	Variant 1	Variant 2	Variant 3
-10V..+10V	-32768..+32767		
0V..+10V	0..+65535	0..+32767	
4..20mA			

There is no single unit that is suitable for all models of analog output module.

Check the scaling provided by the model being used and use the system variables accordingly.

Analog output 0 and analog output 1 can also be managed by the drive parameters. To ensure correction operation, the scaling provided by the external module must be compatible with the scaling provided by the drive.

The drive supplies a datum for the I/O modules scaled as follows

Analog input type	Range
-10V..+10V	-32768..+32767
0V..+10V	0..+65535
4..20mA	+13107..+65535

Analog outputs 0..1 are managed via drive parameters and the value produced by the drive overwrites that written by the MDPLC or serial communication or fieldbus.

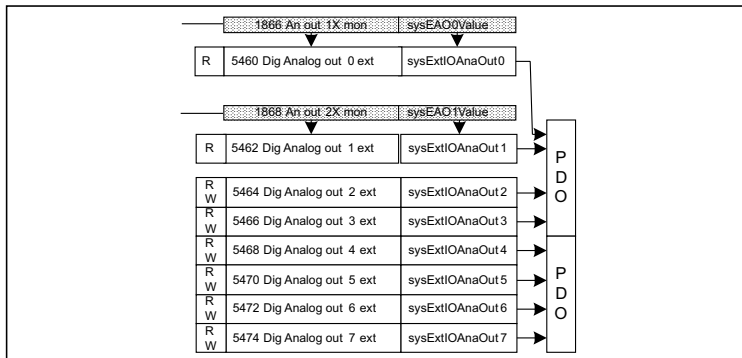

11 - REGULATOR PARAM

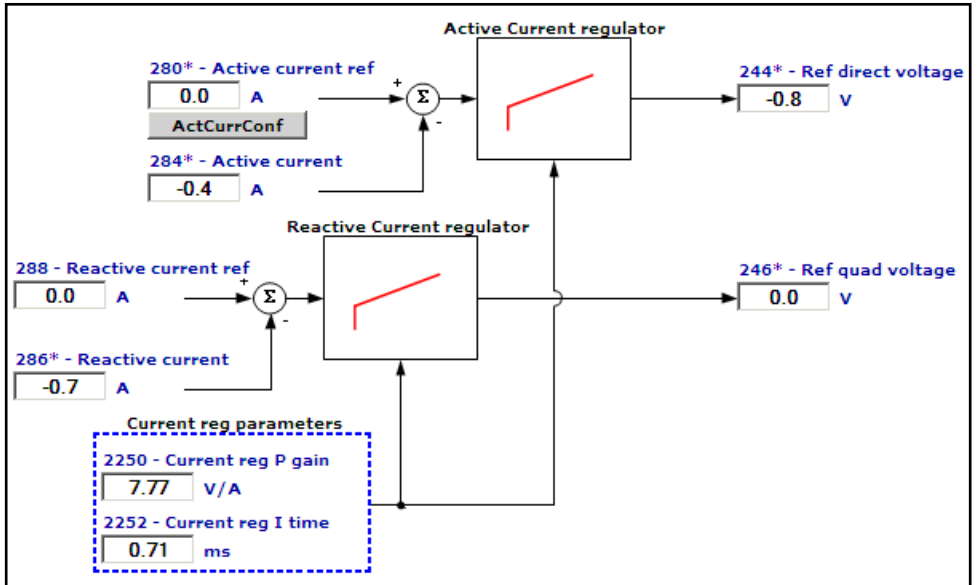

Menu	PAR	Description	UM	Type	FB BIT	Def	Min	Max	Acc
11.1	2250	Current reg P gain	V/A	FLOAT		CALCF	0.0	0.0	ERWS

Setting of the proportional coefficient of the current regulator.

Menu	PAR	Description	UM	Type	FB BIT	Def	Min	Max	Acc
11.2	2252	Current reg I time	ms	FLOAT		CALCF	0.0	0.0	ERWS

Setting of the integral coefficient of the current regulator.

Menu	PAR	Description	UM	Type	FB BIT	Def	Min	Max	Acc
11.3	2270	Voltage reg P gain	A/V	FLOAT		CALCF	0.0	0.0	ERWS

Setting of the proportional coefficient of the voltage regulator.

Menu	PAR	Description	UM	Type	FB BIT	Def	Min	Max	Acc
11.4	2272	Voltage reg I gain	ms	FLOAT		CALCF	0.0	0.0	ERWS

Setting of the integral coefficient of the voltage regulator.

Dead time compensation

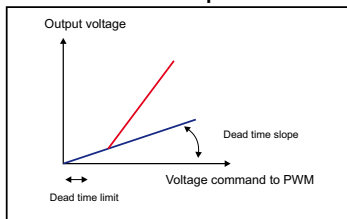

The dead time compensation function (**Dead time compensation**), compensates the distortion of output voltage caused by the voltage drop on the IGBT devices and their switching characteristics.

Menu	PAR	Description	UM	Type	FB BIT	Def	Min	Max	Acc
11.5	2280	Dead time limit	V	FLOAT		SIZE	0.0	50.0	ERWS

Setting of the dead time voltage compensation value.

Menu	PAR	Description	UM	Type	FB BIT	Def	Min	Max	Acc
11.6	2282	Dead time slope	V/A	FLOAT		SIZE	0.0	200.0	ERWS

Setting of the dead time compensation slope value.

12 - ACTIVE CURR CONFIG

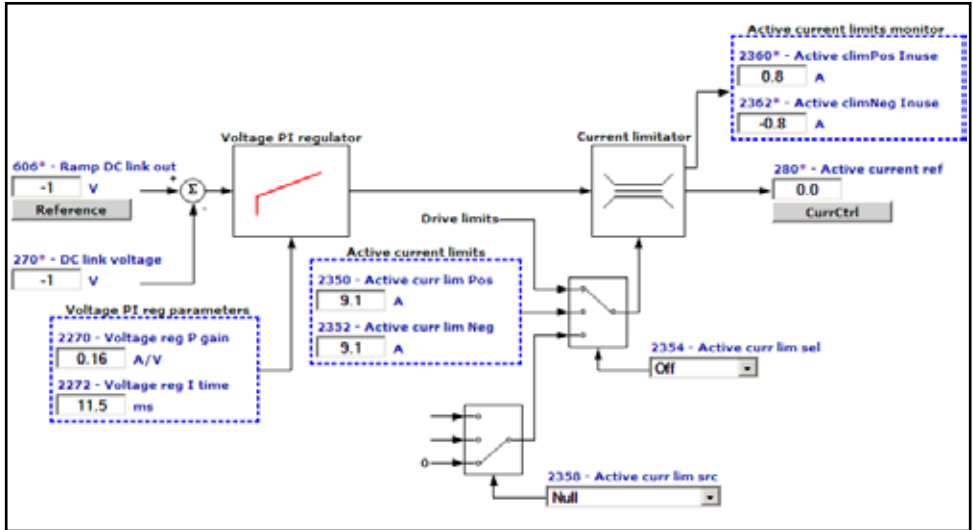

Menu	PAR	Description	UM	Type	FB BIT	Def	Min	Max	Acc
12.1	2350	Active curr lim Pos	A	FLOAT	16/32	CALCF	0.0	CALCF ERWS	

Setting of the AFE active current limit for the positive current direction.

Menu	PAR	Description	UM	Type	FB BIT	Def	Min	Max	Acc
12.2	2352	Active curr lim Neg	A	FLOAT	16/32	CALCF	0.0	CALCF ERWS	

Setting of the AFE active current limit for the negative current direction.

Menu	PAR	Description	UM	Type	FB BIT	Def	Min	Max	Acc
12.3	2354	Active curr lim sel		ENUM		Spento	0	2	ERWZ

Setting of the type of behaviour of the AFE in the current limit condition.

- 0 Off
- 1 Act clim +/-
- 2 Act clim src

If set to **0** no specific type of current limitation is set.

If set to **1** the active positive current limit is **Active curr lim Pos** (PAR 2350) and the active negative current limit is **Active curr lim Neg** (PAR 2352).

If set to **2** the active current limits are symmetrical. The value of parameter PAR 2358 is used as the active current reference value (default = Zero)

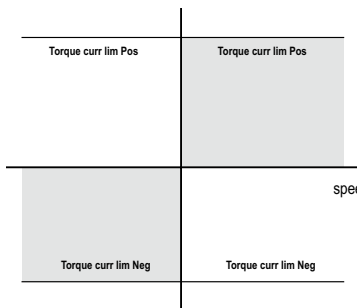

Menu	PAR	Description	UM	Type	FB BIT	Def	Min	Max	Acc
12.4	2358	Active curr lim src		LINK	16/32	6000	0	16384	ERWZ
				L_LIM					

Selection of the origin (source) to be used to set the active current limit.
 The signals that can be associated with the function can be selected from the “L_LIM” selection list.

Menu	PAR	Description	UM	Type	FB BIT	Def	Min	Max	Acc
12.5	2360	Active climPos Inuse	A	FLOAT	16/32	0.0	0.0	0.0	ER

The positive current limit value currently in use is displayed.

Menu	PAR	Description	UM	Type	FB BIT	Def	Min	Max	Acc
12.6	2362	Active climNeg Inuse	A	FLOAT	16/32	0.0	0.0	0.0	ER

The negative current limit value currently in use is displayed.

13 - FUNCTIONS

13.1 -

Reserved for AFE200-PV.

13.2 - FUNCTIONS/DOUBLE PAR SET

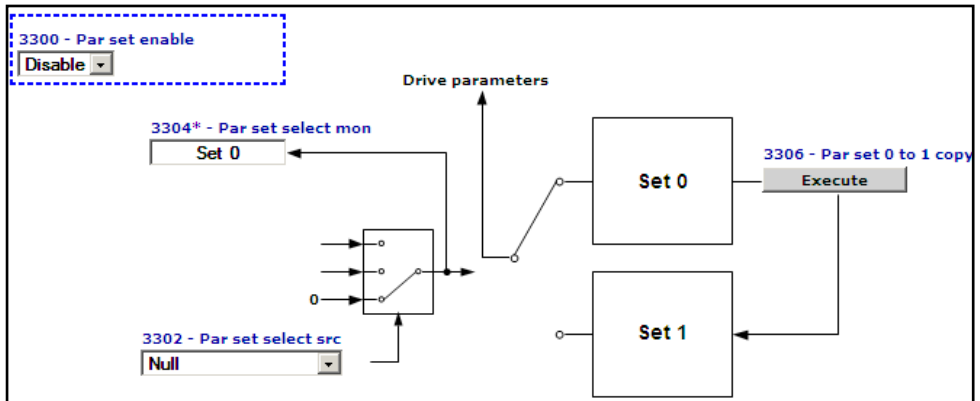

Two independent sets of parameters can be stored in the AFE200. These can be selected via the keypad or by using an external command.

This makes it possible to change all the AFE parameters quickly and automatically according to the various operating requirements.

Menu	PAR	Description	UM	Type	FB BIT	Def	Min	Max	Acc
13.2.1	3300	Par set enable		ENUM		Disable	0	1	ERW
Enabling of management of two parameter sets									
0 Disable									
1 Enable									

When set to **0** only one parameter set is managed (the one used as the default set).

If set to **1** two separate parameter sets can be configured. These can be selected using a command signal on a digital input of the terminal strip.

Menu	PAR	Description	UM	Type	FB BIT	Def	Min	Max	Acc
13.2.2	3302	Par set select src		LINK	16	6000	0	16384	ERWZ
L_DIGSEL2									

Selection of the origin (source) of the signal to be used to select the parameter set to be used. The terminal or digital command that can be associated with this function can be selected from among those available in the "L_DIGSEL2" selection list.

Menu	PAR	Description	UM	Type	FB BIT	Def	Min	Max	Acc
13.2.3	3304	Par set select mon		ENUM	16	Set 0	0	0	ER
The parameter set currently in use is displayed.									
0 Set 0 1 Set 1									

Menu	PAR	Description	UM	Type	FB BIT	Def	Min	Max	Acc
13.2.4	3306	Par set 0 to 1 copy		BIT		0	0	1	ERW

Procedures for setting up and managing the double parameter set

Creating the second set:

This function copies parameter set 0 onto set 1. Before enabling management of the double parameter set, the first set should be programmed with the correct values.

When the first set is ready, the second can be activated as follows:

1. Activate management of the double parameter set by enabling parameter **3300 Par set enable**.
2. Copy set 0 onto set 1 using command **3306 Par set 0 to 1 copy**.
This creates an initial parameter base in set 1 to which changes can be made. Save the parameters.
3. Activate set 1 using parameter **3302 Par set select src**.
To select set 1 manually, set this parameter to **"One"**.
Otherwise select the desired source.
4. Modify the parameters in set 1 as necessary.
5. Save the parameters.

You can change the set being used by changing the source selected in parameter **3302 Par set select src**. This can only be changed with the AFE disabled.

When the double parameter set is active, the number of the set being used is shown next to the number of each parameter on the keypad.

Modifying and saving parameters:

When the double parameter set is active, any parameters that need to be the same in the two sets must be modified in each set separately.

Parameters are only saved in the set that is active at the time. To save both sets, you must first save one and then select and save the other.

Note!

Any changes to the parameters regarding the "parameter sets", performed when enabled, will be lost at the next switching unless a **Par set 0 to 1 copy** command is sent.

To save data permanently (even when the AFE is switched off), send the **Save parameters** command (DRIVE CONFIG menu).

13.3 - FUNCTIONS/COMPARE

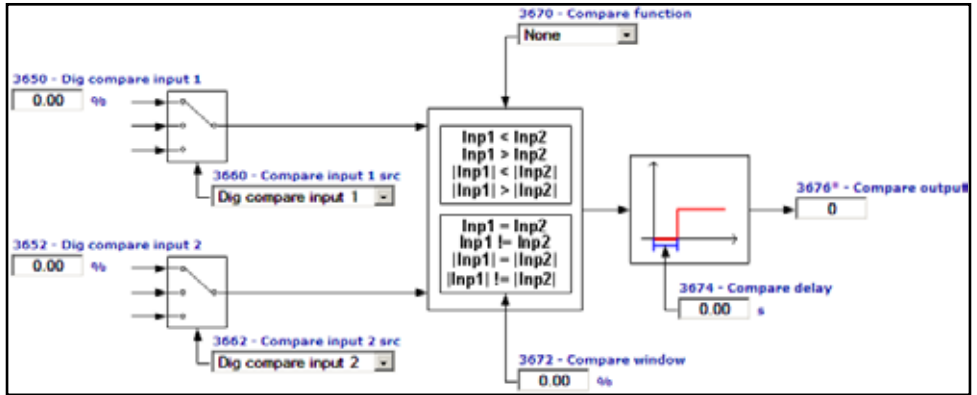

This function allows the comparison among two signals or values.

Menu	PAR	Description	UM	Type	FB BIT	Def	Min	Max	Acc
13.3.1	3650	Dig compare input 1	perc	FLOAT	32	0.0	-100.0	100.0	ERW

Setting of the digital value of the first element of comparison.

Menu	PAR	Description	UM	Type	FB BIT	Def	Min	Max	Acc
13.3.2	3652	Dig compare input 2	perc	FLOAT	32	0.0	-100.0	100.0	ERW

Setting of the digital value of the second element of comparison.

Menu	PAR	Description	UM	Type	FB BIT	Def	Min	Max	Acc
13.3.3	3660	Compare input 1 src		LINK	32	3650	0	16384	ERW

L_CMP

Selection of the origin (source) of the signal to be used as the first term of comparison. The values that can be selected in the compare function are listed in the “L_CMP” selection list.

Menu	PAR	Description	UM	Type	FB BIT	Def	Min	Max	Acc
13.3.4	3662	Compare input 2 src		LINK	32	3652	0	16384	ERW

L_CMP

Selection of the origin (source) of the signal to be used as the second term of comparison. The values that can be selected in the compare function are listed in the “L_CMP” selection list.

Menu	PAR	Description	UM	Type	FB BIT	Def	Min	Max	Acc
13.3.5	3670	Compare function		ENUM		None	0	8	ERW

Setting of the compare function between **Compare input 2** and **Compare input 1** to enable **Cmp output**.

- 0 None
- 1 Ingr1=Ingr2

- 2 Ingr1!=Ingr2
- 3 Ingr1<Ingr2
- 4 Ingr1>Ingr2
- 5 |Ingr1|=|Ingr2|
- 6 |Ingr1|!=|Ingr2|
- 7 |Ingr1|<|Ingr2|
- 8 |Ingr1|>|Ingr2|

If set to **0** the comparator is not enabled

If set to **1** the comparator output is enabled when the value of **Dig compare input 1** is inside the window resulting from the value of **Dig compare input 2** \pm the tolerance set via the **Comparator Window**.

If set to **2** the comparator output is enabled when the value of **Dig compare input 1** is not inside the window resulting from the value of **Dig compare input 2** \pm the tolerance set via the **Comparator Window**.

If set to **3** the comparator output is enabled when **Compare input 1** is less than **Compare input 2**.

If set to **4** the comparator output is enabled when **Compare input 1** is greater than **Compare input 2**.

If set to **5** the comparator output is enabled when the value of **Dig compare input 1** is inside the window resulting from the absolute value of **Dig compare input 2** \pm the tolerance set via the **Comparator Window**.

If set to **6** the comparator output is enabled when the absolute value of **Dig compare input 1** is not inside the window resulting from the absolute value of **Dig compare input 2** \pm the tolerance set via the **Comparator Window**.

If set to **7** the comparator output is enabled when the absolute value of **Dig compare input 1** is less than the absolute value of **Dig compare input 2**.

If set to **8** the comparator output is enabled when the absolute value of **Dig compare input 1** is more than the absolute value of **Dig compare input 2**.

Menu	PAR	Description	UM	Type	FB BIT	Def	Min	Max	Acc
13.3.6	3672	Compare window	perc	FLOAT		0.0	0.0	100.0	ERW

Setting of the tolerance window for comparing the **Dig compare input 1** and **Dig compare input 2** signals.

Menu	PAR	Description	UM	Type	FB BIT	Def	Min	Max	Acc
13.3.7	3674	Compare delay	s	FLOAT		0.0	0.0	30.0	ERW

Setting of the delay for signalling the result of the comparison.

Menu	PAR	Description	UM	Type	FB BIT	Def	Min	Max	Acc
13.3.8	3676	Compare output		BIT	16	0	0	1	ER

The status of the comparator output is displayed:

- 0 The result of the set comparison is negative
- 1 The result of the set comparison is positive

13.4 - FUNCTIONS/PADS

The general variables are used to exchange data between the various components of a Bus system. They are similar to the variables of a PLC. The basic structure of the system is illustrated below. Pads can be used, for example, to send information from a fieldbus to an optional card. All Pads can be read and written.

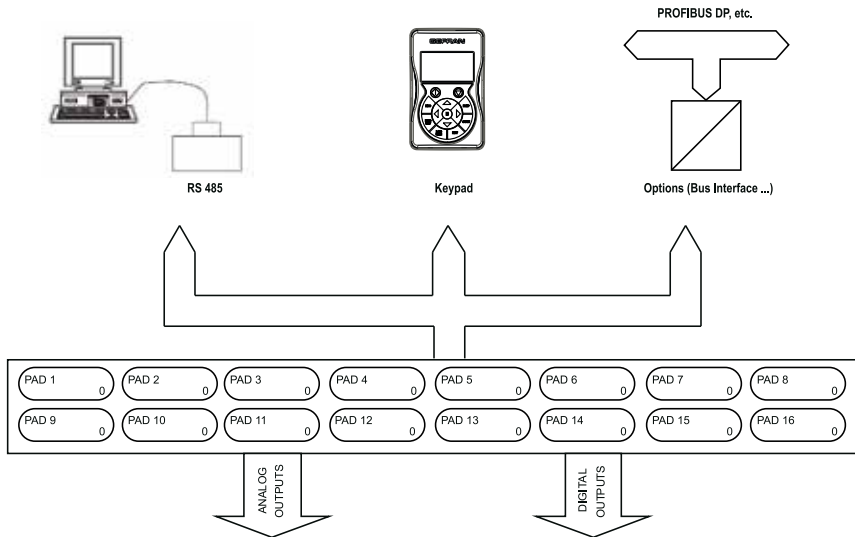

Menu	PAR	Description	UM	Type	FB BIT	Def	Min	Max	Acc
13.4.1	3700	Pad 1		INT32	32	0	0	0	ERW
13.4.2	3702	Pad 2		INT32	32	0	0	0	ERW
13.4.3	3704	Pad 3		INT32	32	0	0	0	ERW
13.4.4	3706	Pad 4		INT32	32	0	0	0	ERW
13.4.5	3708	Pad 5		INT32	32	0	0	0	ERW
13.4.6	3710	Pad 6		INT32	32	0	0	0	ERW
13.4.7	3712	Pad 7		INT32	32	0	0	0	ERW
13.4.8	3714	Pad 8		INT32	32	0	0	0	ERW
13.4.9	3716	Pad 9		INT32	32	0	0	0	ERW
13.4.10	3718	Pad 10		INT32	32	0	0	0	ERW
13.4.11	3720	Pad 11		INT32	32	0	0	0	ERW
13.4.12	3722	Pad 12		INT32	32	0	0	0	ERW
13.4.13	3724	Pad 13		INT32	32	0	0	0	ERW
13.4.14	3726	Pad 14		INT32	32	0	0	0	ERW
13.4.15	3728	Pad 15		INT32	32	0	0	0	ERW
13.4.16	3730	Pad 16		INT32	32	0	0	0	ERW

Setting of general, 32 Bit variables. PAD parameters can be used as supporting parameters to send values written by the fieldbus, serial line, etc. to analog or digital outputs.

14 - COMMUNICATION

The AFE200 is provided with a standard port (9 pole sub-D connector: XS) for connecting the RS485 serial line used for AFE-PC point-to-point communication (via the GF-eXpress configuration software) or for the multidrop connection.

The RS485 serial line format is: 8 data bits, no parity and one stop bit.

14.1 - COMMUNICATION/RS485

Menu	PAR	Description	UM	Type	FB BIT	Def	Min	Max	Acc
14.1.1	3800	Drive address		UINT16		1	1	255	ERW

Setting of the address to which the AFE responds when connected to the RS485 serial line.

Menu	PAR	Description	UM	Type	FB BIT	Def	Min	Max	Acc
14.1.2	3802	Serial baudrate		ENUM		38400	0	2	ERW

Setting of the RS485 serial communication speed (Baud Rate).

- 0 9600
- 1 19200
- 2 38400

Menu	PAR	Description	UM	Type	FB BIT	Def	Min	Max	Acc
14.1.3	3810	Serial parameter		ENUM		None,8,1	0	3	ERW

Setting of the format of the RS485 serial communication data.

- 0 None,8,1
- 1 None,8,2
- 2 Even,8,1
- 3 Odd,8,1

Menu	PAR	Description	UM	Type	FB BIT	Def	Min	Max	Acc
14.1.4	3804	Serial protocol		ENUM		Modbus	0	1	ERW

Setting of the serial communication protocol:

- 0 Modbus
- 1 Jbus

Setting to **0** selects the Modbus RTU (Remote Terminal Unit) serial communication protocol.

Setting to **1** selects the Jbus serial communication protocol. The Jbus protocol is functionally identical to the Modbus, except for the different numbering of addresses: in the Modbus these start from zero (0000 = 1st address) while in the JBUS they start from one (0001 = 1st address) and maintain this difference throughout numbering.

Menu	PAR	Description	UM	Type	FB BIT	Def	Min	Max	Acc
14.1.5	3806	Serial delay	ms	UINT16		0	0	1000	ERW

Setting of the minimum delay between the AFE receiving the last byte and starting its response. This delay avoids conflicts on the serial line when the RS485 interface that is used has not been pre-set for automatic Tx/Rx switching. The parameter only concerns the use of the standard RS485 serial line.

Example: if the delay in Tx/Rx switching on the master is a maximum of 20ms, the **Ser answer delay** parameter must be set to at least 20ms: 22ms

Menu	PAR	Description	UM	Type	FB BIT	Def	Min	Max	Acc
14.1.6	3808	Serial swap data		BIT		0	0	1	ERW

This parameter enables the exchange of the reading of the High and Low parts of the words for FLOAT type parameters when using the Modbus protocol.

14.2 - COMMUNICATION/FIELDBUS CONFIG

Menu	PAR	Description	UM	Type	FB BIT	Def	Min	Max	Acc
14.2.1	4000	Fieldbus type		ENUM		Off	0	5	RW

Setting of the type of fieldbus to be used..

- 0** Off
- 1** CANopen
- 2** DeviceNet
- 3** Profibus
- 40** Cansync master
- 41** Cansync slave
- 42** RTE

If set to **0** no fieldbus is selected.

If set to **1** the CANopen fieldbus profile is selected.

If set to **2** the ProfiBus-DP fieldbus profile is selected.

If set to **3** the DeviceNet fieldbus profile is selected.

If set to **40** the AFE is selected as the master device (*).

If set to **41** the AFE is selected as the slave device (*).

Set **42** to select the Real Time Ethernet card.

(*) Only one AFE can be the master device, all the others must be slave devices. When the slave device is synchronised the SPD0 LED on the keypad lights up; the LED on the master AFE is always off.

Menu	PAR	Description	UM	Type	FB BIT	Def	Min	Max	Acc
14.2.2	4004	Fieldbus baudrate		ENUM		500k	0	12	RW

Setting of the communication network speed (Baud Rate).

- 0** Auto
- 1** 125k
- 2** 250k
- 3** 500k
- 4** 1M
- 5** 9600
- 6** 19200
- 7** 93750
- 8** 187,5k
- 9** 1,5M
- 10** 3M
- 11** 6M
- 12** 12M

Menu	PAR	Description	UM	Type	FB BIT	Def	Min	Max	Acc
14.2.3	4006	Fieldbus address		INT16		3	0	255	RW

Setting of the node address of the AFE when connected to the network.

Menu	PAR	Description	UM	Type	FB BIT	Def	Min	Max	Acc
14.2.4	4010	Fieldbus M->S enable		ENUM		Enable	0	1	ERWZ

Setting of fieldbus data updating.

- 0 Disable
- 1 Enable

If set to **0**, the possibility of sending commands and references from the AFE PLC via the fieldbus is disabled.

If set to **1** the possibility of sending commands and references from the AFE PLC via the fieldbus is enabled.

Menu	PAR	Description	UM	Type	FB BIT	Def	Min	Max	Acc
14.2.5	4012	Fieldbus alarm mode		INT32		0	0	1	ERWZ

Setting of the **Opt Bus Fault** alarm generation mode.

- 0 Off
- 1 On

If set to **0** the alarm is only generated if the AFE is enabled.

If set to **1** the alarm is generated even with the AFE disabled.

Menu	PAR	Description	UM	Type	FB BIT	Def	Min	Max	Acc
14.2.6	4014	Fieldbus state		ENUM		Stop	0	7	R

The logic status of the fieldbus connection is displayed. The value depends on the type of bus that is used.

These logic states are displayed if the selected fieldbus is CANopen or RTE:

- 0 Stop
- 1 PreOperational
- 2 Operational

These logic states are displayed if the selected fieldbus is Profibus:

- 3 Error
- 4 WaitPRM
- 5 WaitCFG
- 6 DataExchange
- 7 DPErrror

The following logic states are displayed if the RTE field bus is selected:

- 8 SAFE OP
- 9 INIT

Menu	PAR	Description	UM	Type	FB BIT	Def	Min	Max	Acc
14.2.7	4398	RTE protocol		ENUM		None	0	6	ER

The Real Time Ethernet protocol implemented on the expansion card is displayed.

- 0 None
- 1 Ethercat
- 2 EthernetIP
- 3 GdNet
- 4 Profinet
- 5 ModbusTCP
- 6 Powerlink

Menu	PAR	Description	UM	Type	FB BIT	Def	Min	Max	Acc
14.2.8	5608	IP address		UINT32		0	0	4294967295	ER

Display of DCP address set via configuration of Profinet node.

14.3 - COMMUNICATION/FIELDBUS M2S

Menu	PAR	Description	UM	Type	FB BIT	Def	Min	Max	Acc
14.3.1	4020	Fieldbus M->S1 ipa		FBM2SIPA		0	0	0	R
14.3.5	4030	Fieldbus M->S2 ipa		FBM2SIPA		0	0	0	R
14.3.9	4040	Fieldbus M->S3 ipa		FBM2SIPA		0	0	0	R
14.3.13	4050	Fieldbus M->S4 ipa		FBM2SIPA		0	0	0	R
14.3.17	4060	Fieldbus M->S5 ipa		FBM2SIPA		0	0	0	R
14.3.21	4070	Fieldbus M->S6 ipa		FBM2SIPA		0	0	0	R
14.3.25	4080	Fieldbus M->S7 ipa		FBM2SIPA		0	0	0	R
14.3.29	4090	Fieldbus M->S8 ipa		FBM2SIPA		0	0	0	R
14.3.33	4100	Fieldbus M->S9 ipa		FBM2SIPA		0	0	0	R
14.3.37	4110	Fieldbus M->S10 ipa		FBM2SIPA		0	0	0	R
14.3.41	4120	Fieldbus M->S11 ipa		FBM2SIPA		0	0	0	R
14.3.45	4130	Fieldbus M->S12 ipa		FBM2SIPA		0	0	0	R
14.3.49	4140	Fieldbus M->S13 ipa		FBM2SIPA		0	0	0	R
14.3.53	4150	Fieldbus M->S14 ipa		FBM2SIPA		0	0	0	R
14.3.57	4160	Fieldbus M->S15 ipa		FBM2SIPA		0	0	0	R
14.3.61	4170	Fieldbus M->S16 ipa		FBM2SIPA		0	0	0	R

Setting of the parameter to associate with the bus channel. The default setting is **0**, which means channel not active.

If the parameter to be connected is a **sorg** (source), the channel and parameter can also be associated by modifying the **sorg** parameter in its menu.

When setting a parameter, the format is also automatically set in the sys parameter.

Menu	PAR	Description	UM	Type	FB BIT	Def	Min	Max	Acc
14.3.2	4022	Fieldbus M->S1 sys		ENUM		Not assigned	0	10	RW
14.3.6	4032	Fieldbus M->S2 sys		ENUM		Not assigned	0	10	RW
14.3.10	4042	Fieldbus M->S3 sys		ENUM		Not assigned	0	10	RW
14.3.14	4052	Fieldbus M->S4 sys		ENUM		Not assigned	0	10	RW
14.3.18	4062	Fieldbus M->S5 sys		ENUM		Not assigned	0	10	RW
14.3.22	4072	Fieldbus M->S6 sys		ENUM		Not assigned	0	10	RW
14.3.26	4082	Fieldbus M->S7 sys		ENUM		Not assigned	0	10	RW
14.3.30	4092	Fieldbus M->S8 sys		ENUM		Not assigned	0	10	RW
14.3.34	4102	Fieldbus M->S9 sys		ENUM		Not assigned	0	10	RW
14.3.38	4112	Fieldbus M->S10 sys		ENUM		Not assigned	0	10	RW
14.3.42	4122	Fieldbus M->S11 sys		ENUM		Not assigned	0	10	RW
14.3.46	4132	Fieldbus M->S12 sys		ENUM		Not assigned	0	10	RW
14.3.50	4142	Fieldbus M->S13 sys		ENUM		Not assigned	0	10	RW
14.3.54	4152	Fieldbus M->S14 sys		ENUM		Not assigned	0	10	RW
14.3.58	4162	Fieldbus M->S15 sys		ENUM		Not assigned	0	10	RW
14.3.62	4172	Fieldbus M->S16 sys		ENUM		Not assigned	0	10	RW

Setting of the format of the datum received on the channel. When the **src** parameter is programmed, the format is automatically programmed on the relative **sys** . If the **src** parameter is reset to **null** , the format does not change. The value of the format can be selected from the following list, according to the parameter selected as the source:

- 0 Not assigned
- 1 Count 16
- 2 Count 32
- 3 Fill 16
- 4 Fill 32
- 5 Mdplc 16
- 6 Mdplc 32
- 7 EU
- 8 Eu float
- 9 Par 16
- 10 Par 32

If set to **0** the channel is not assigned.
 If set to **1** the datum is assigned a 16-bit count.
 If set to **2** the datum is assigned a 32-bit count.
 If set to **3** 16 bits on the channel are reserved for the datum, not used.
 If set to **4** 32 bits on the channel are reserved for the datum, not used.
 If set to **5** the datum is assigned a 16-bit count used by MDPLC.
 If set to **6** the datum is assigned a 32-bit count used by MDPLC.
 If set to **7** the datum is assigned engineering units on a 16-bit integer.
 If set to **8** the datum is assigned engineering units on a 32-bit integer.
 If set to **9**, the datum is assigned a 16-bit integer engineering unit format not in real time (5-10ms)
 If set to **10** the datum is assigned a 32-bit integer engineering unit format or float format if the associated parameter is a float-type parameter not in real time (5-10ms)

Note!

If the **sys** parameter is not assigned, none of the subsequent fieldbus channels are read, even if programmed.

Menu	PAR	Description	UM	Type	FB BIT	Def	Min	Max	Acc
14.3.3	4024	Fieldbus M->S1 mon		INT32	32	0	0	0	ER
14.3.7	4034	Fieldbus M->S2 mon		INT32	32	0	0	0	ER
14.3.11	4044	Fieldbus M->S3 mon		INT32	32	0	0	0	ER
14.3.15	4054	Fieldbus M->S4 mon		INT32	32	0	0	0	ER
14.3.19	4064	Fieldbus M->S5 mon		INT32	32	0	0	0	ER
14.3.23	4074	Fieldbus M->S6 mon		INT32	32	0	0	0	ER
14.3.27	4084	Fieldbus M->S7 mon		INT32	32	0	0	0	ER
14.3.31	4094	Fieldbus M->S8 mon		INT32	32	0	0	0	ER
14.3.35	4104	Fieldbus M->S9 mon		INT32	32	0	0	0	ER
14.3.39	4114	Fieldbus M->S10 mon		INT32	32	0	0	0	ER
14.3.43	4124	Fieldbus M->S11 mon		INT32	32	0	0	0	ER
14.3.47	4134	Fieldbus M->S12 mon		INT32	32	0	0	0	ER
14.3.51	4144	Fieldbus M->S13 mon		INT32	32	0	0	0	ER
14.3.55	4154	Fieldbus M->S14 mon		INT32	32	0	0	0	ER
14.3.59	4164	Fieldbus M->S15 mon		INT32	32	0	0	0	ER
14.3.63	4174	Fieldbus M->S16 mon		INT32	32	0	0	0	ER

The value received from the bus is displayed. This parameter must be associated with the src parameter to enable the **M->S** channel.

The user may modify the **M->S** and by **S->M sys** parameters. The consistency of the sys with the parameter assigned to the channel is checked.

Check for channels M->S:

Sys parameter	FB type	result
Count 32	32 bit	Receives 32 bits from FB and copies to 32 bits of monitor. OK
	32_H	Receives 32 bits from FB and copies to 32 bits of monitor. OK
	32_L	Receives 32 bits from FB and copies to 32 bits of monitor. OK
Count 16 monitor. Error	16 bit	Receives 16 bits from FB and doesn't know whether to copy to 16H or 16L of
	16_H	Receives 16 bits from FB and copies to 16H bit of monitor. OK
	16_L	Receives 16 bits from FB and copies to 16L bit of monitor. OK

A **Fieldbus M->S X Mon** parameter can only be assigned to a single “src”. If assigned to more than one **src**, an error signal is generated during fieldbus initialization.

Menu	PAR	Description	UM	Type	FB BIT	Def	Min	Max	Acc
14.3.4	4026	Fieldbus M->S1 div		FLOAT		1.0	1.0	1000.0	ERW
14.3.8	4036	Fieldbus M->S2 div		FLOAT		1.0	1.0	1000.0	ERW
14.3.12	4046	Fieldbus M->S3 div		FLOAT		1.0	1.0	1000.0	ERW
14.3.16	4056	Fieldbus M->S4 div		FLOAT		1.0	1.0	1000.0	ERW
14.3.20	4066	Fieldbus M->S5 div		FLOAT		1.0	1.0	1000.0	ERW
14.3.24	4076	Fieldbus M->S6 div		FLOAT		1.0	1.0	1000.0	ERW
14.3.28	4086	Fieldbus M->S7 div		FLOAT		1.0	1.0	1000.0	ERW
14.3.32	4096	Fieldbus M->S8 div		FLOAT		1.0	1.0	1000.0	ERW
14.3.36	4106	Fieldbus M->S9 div		FLOAT		1.0	1.0	1000.0	ERW
14.3.40	4116	Fieldbus M->S10 div		FLOAT		1.0	1.0	1000.0	ERW
14.3.44	4126	Fieldbus M->S11 div		FLOAT		1.0	1.0	1000.0	ERW
14.3.48	4136	Fieldbus M->S12 div		FLOAT		1.0	1.0	1000.0	ERW
14.3.52	4146	Fieldbus M->S13 div		FLOAT		1.0	1.0	1000.0	ERW
14.3.56	4156	Fieldbus M->S14 div		FLOAT		1.0	1.0	1000.0	ERW
14.3.60	4166	Fieldbus M->S15 div		FLOAT		1.0	1.0	1000.0	ERW
14.3.64	4176	Fieldbus M->S16 div		FLOAT		1.0	1.0	1000.0	ERW

The **Div M->Sx fieldbus** parameters can be used to increase the resolution of the datum sent on the bus to the AFE in the corresponding channel in EU and EU_float exchange mode. The parameter value is used by the AFE as the divider of the incoming datum, so that a number with decimal digits can be transferred.

Note!

You must check the size in bits of the datum that is sent to make sure that the maximum value in bits fits in a 16-bit integer. For example, if specifying the divider as “**Fieldbus M->Sn div**” = 1000, the maximum value that can be used for the exchanged datum is 32.768 (32768/1000).

l.e. : Fieldbus M->S1 div = 10, Fieldbus S->M1 ipa = Ramp ref src 1, Fieldbus M->S1 sys = Eu. If the PLC sends the decimal value 1000 on the first word the value of **DC voltage ref src** on the AFE is 1000/10 = 100.

14.4 - COMMUNICATION/FIELDBUS S2M

Menu	PAR	Description	UM	Type	FB BIT	Def	Min	Max	Acc
14.4.1	4180	Fieldbus S->M1 ipa		FBM2SIPA		0	0	20000	RW
14.4.5	4190	Fieldbus S->M2 ipa		FBM2SIPA		0	0	20000	RW
14.4.9	4200	Fieldbus S->M3 ipa		FBM2SIPA		0	0	20000	RW
14.4.13	4210	Fieldbus S->M4 ipa		FBM2SIPA		0	0	20000	RW
14.4.17	4220	Fieldbus S->M5 ipa		FBM2SIPA		0	0	20000	RW
14.4.21	4230	Fieldbus S->M6 ipa		FBM2SIPA		0	0	20000	RW
14.4.25	4240	Fieldbus S->M7 ipa		FBM2SIPA		0	0	20000	RW
14.4.29	4250	Fieldbus S->M8 ipa		FBM2SIPA		0	0	20000	RW
14.4.33	4260	Fieldbus S->M9 ipa		FBM2SIPA		0	0	20000	RW

14.4.37	4270	Fieldbus S->M10 ipa	FBM2SIPA	0	0	20000	RW
14.4.41	4280	Fieldbus S->M11 ipa	FBM2SIPA	0	0	20000	RW
14.4.45	4290	Fieldbus S->M12 ipa	FBM2SIPA	0	0	20000	RW
14.4.49	4300	Fieldbus S->M13 ipa	FBM2SIPA	0	0	20000	RW
14.4.53	4310	Fieldbus S->M14 ipa	FBM2SIPA	0	0	20000	RW
14.4.57	4320	Fieldbus S->M15 ipa	FBM2SIPA	0	0	20000	RW
14.4.61	4330	Fieldbus S->M16 ipa	FBM2SIPA	0	0	20000	RW

Setting of the parameter to associate with the bus channel. The default setting is **0**, which means channel not active.

When setting a parameter, the format is also automatically set in the **sys** parameter

Menu	PAR	Description	UM	Type	FB BIT	Def	Min	Max	Acc
14.4.2	4182	Fieldbus S->M1 sys		ENUM		Not assigned	0	10	RW
14.4.6	4192	Fieldbus S->M2 sys		ENUM		Not assigned	0	10	RW
14.4.10	4202	Fieldbus S->M3 sys		ENUM		Not assigned	0	10	RW
14.4.14	4212	Fieldbus S->M4 sys		ENUM		Not assigned	0	10	RW
14.4.18	4222	Fieldbus S->M5 sys		ENUM		Not assigned	0	10	RW
14.4.22	4232	Fieldbus S->M6 sys		ENUM		Not assigned	0	10	RW
14.4.26	4242	Fieldbus S->M7 sys		ENUM		Not assigned	0	10	RW
14.4.30	4252	Fieldbus S->M8 sys		ENUM		Not assigned	0	10	RW
14.4.34	4262	Fieldbus S->M9 sys		ENUM		Not assigned	0	10	RW
14.4.38	4272	Fieldbus S->M10 sys		ENUM		Not assigned	0	10	RW
14.4.42	4282	Fieldbus S->M11 sys		ENUM		Not assigned	0	10	RW
14.4.46	4292	Fieldbus S->M12 sys		ENUM		Not assigned	0	10	RW
14.4.50	4302	Fieldbus S->M13 sys		ENUM		Not assigned	0	10	RW
14.4.54	4312	Fieldbus S->M14 sys		ENUM		Not assigned	0	10	RW
14.4.58	4322	Fieldbus S->M15 sys		ENUM		Not assigned	0	10	RW
14.4.62	4332	Fieldbus S->M16 sys		ENUM		Not assigned	0	10	RW

When setting the **sorg** parameter the format is automatically set on the relative **sys**.

If **sorg** is set to **null**, the data format does not change. The value of the format can be selected from the following list, according to the parameter selected as the source:

- 0 Not assigned
- 1 Count 16
- 2 Count 32
- 3 Fill 16
- 4 Fill 32
- 5 Mdplc 16
- 6 Mdplc 32
- 7 EU
- 8 Eu float
- 9 Par 16
- 10 Par 32

If set to **0** the channel is not assigned.

If set to **1** the datum is assigned a 16-bit count.

If set to **2** the datum is assigned a 32-bit count.

If set to **3** 16 bits on the channel are reserved for the datum, not used.

If set to **4** 32 bits on the channel are reserved for the datum, not used.

If set to **5** the datum is assigned a 16-bit count used by MDPLC.

If set to **6** the datum is assigned a 32-bit count used by MDPLC.

If set to **7** the datum is assigned engineering units on a 16-bit integer.

If set to **8** the datum is assigned engineering units on a 32-bit integer.

If set to **9**, the datum is assigned a 16-bit integer engineering unit format not in real time (5-10ms)

If set to **10** the datum is assigned a 32-bit integer engineering unit format or float for-mat if the associated parameter is a float-type parameter not in real time (5-10ms)

Note!

If the **sys** parameter is not assigned, none of the subsequent channels are transferred to the fieldbus, even if programmed.

Menu	PAR	Description	UM	Type	FB BIT	Def	Min	Max	Acc
14.4.3	4184	Dig Fieldbus S->M1		INT32	32	0	0	0	ERW
14.4.7	4194	Dig Fieldbus S->M2		INT32	32	0	0	0	ERW
14.4.11	4204	Dig Fieldbus S->M3		INT32	32	0	0	0	ERW
14.4.15	4214	Dig Fieldbus S->M4		INT32	32	0	0	0	ERW
14.4.19	4224	Dig Fieldbus S->M5		INT32	32	0	0	0	ERW
14.4.23	4234	Dig Fieldbus S->M6		INT32	32	0	0	0	ERW
14.4.27	4244	Dig Fieldbus S->M7		INT32	32	0	0	0	ERW
14.4.31	4254	Dig Fieldbus S->M8		INT32	32	0	0	0	ERW
14.4.35	4264	Dig Fieldbus S->M9		INT32	32	0	0	0	ERW
14.4.39	4274	Dig Fieldbus S->M10		INT32	32	0	0	0	ERW
14.4.43	4284	Dig Fieldbus S->M11		INT32	32	0	0	0	ERW
14.4.47	4294	Dig Fieldbus S->M12		INT32	32	0	0	0	ERW
14.4.51	4304	Dig Fieldbus S->M13		INT32	32	0	0	0	ERW
14.4.55	4314	Dig Fieldbus S->M14		INT32	32	0	0	0	ERW
14.4.59	4324	Dig Fieldbus S->M15		INT32	32	0	0	0	ERW
14.4.63	4334	Dig Fieldbus S->M16		INT32	32	0	0	0	ERW

If associated with the relative **src**, the value of this parameter is sent to the bus. The user may modify the **M->S** and by **S->M sys** parameters. The consistency of the sys with the parameter assigned to the channel is checked.

Check for channels S->M:

Sys parameter	FB type	result
Count 32	32 bit	Sends all 32 bits of input to fieldbus. OK
	16_H	Sends all 32 bits of input to fieldbus. OK
	16_L	Sends all 32 bits of input to fieldbus. OK
Count 16	32 bit	Doesn't know whether to send 16H or 16L. Error
	16_H	Sends all 16H bits of input to fieldbus. OK
	16_L	Sends all 16L bits of input to fieldbus. OK

Menu	PAR	Description	UM	Type	FB BIT	Def	Min	Max	Acc
14.4.4	4186	Fieldbus S->M1 mul		FLOAT		1.0	1.0	1000.0	ERW
14.4.8	4196	Fieldbus S->M2 mul		FLOAT		1.0	1.0	1000.0	ERW
14.4.12	4206	Fieldbus S->M3 mul		FLOAT		1.0	1.0	1000.0	ERW
14.4.16	4216	Fieldbus S->M4 mul		FLOAT		1.0	1.0	1000.0	ERW
14.4.20	4226	Fieldbus S->M5 mul		FLOAT		1.0	1.0	1000.0	ERW
14.4.24	4236	Fieldbus S->M6 mul		FLOAT		1.0	1.0	1000.0	ERW
14.4.28	4246	Fieldbus S->M7 mul		FLOAT		1.0	1.0	1000.0	ERW
14.4.32	4256	Fieldbus S->M8 mul		FLOAT		1.0	1.0	1000.0	ERW
14.4.36	4266	Fieldbus S->M9 mul		FLOAT		1.0	1.0	1000.0	ERW
14.4.40	4276	Fieldbus S->M10 mul		FLOAT		1.0	1.0	1000.0	ERW
14.4.44	4286	Fieldbus S->M11 mul		FLOAT		1.0	1.0	1000.0	ERW
14.4.48	4296	Fieldbus S->M12 mul		FLOAT		1.0	1.0	1000.0	ERW
14.4.52	4306	Fieldbus S->M13 mul		FLOAT		1.0	1.0	1000.0	ERW
14.4.56	4316	Fieldbus S->M14 mul		FLOAT		1.0	1.0	1000.0	ERW
14.4.60	4326	Fieldbus S->M15 mul		FLOAT		1.0	1.0	1000.0	ERW
14.4.64	4336	Fieldbus S->M16 mul		FLOAT		1.0	1.0	1000.0	ERW

The **Fieldbus S->Mx mul** parameters are multipliers that the AFE applies to the datum before sending it to the bus. It is therefore possible to increase the resolution of some values read in EU and EU_float mode, also using decimal digits.

Note!

The AFE does not check that the multiplied parameter expressed in bits fits in a 16-bit integer. You must make sure that the multiplier is compatible with the maximum value of the exchanged parameter and that it does not exceed the maximum size of 32768.

I.e.: **Fieldbus S->Mx mul** = 10, **Fieldbus S->M1 ipa** = Output voltage, **Fieldbus S->M1 sys** = Eu. If the voltage is 400V, the PLC reads the value 400 * 10 = 4000 on the first word exchanged.

14.5 - COMMUNICATION/WORD COMP

Menu	PAR	Description	UM	Type	FB BIT	Def	Min	Max	Acc
14.5.1	4400	Word bit0 src		LINK	16	6000	0	16384	ERW
14.5.2	4402	Word bit1 src		LINK	16	6000	0	16384	ERW
14.5.3	4404	Word bit2 src		LINK	16	6000	0	16384	ERW
14.5.4	4406	Word bit3 src		LINK	16	6000	0	16384	ERW
14.5.5	4408	Word bit4 src		LINK	16	6000	0	16384	ERW
14.5.6	4410	Word bit5 src		LINK	16	6000	0	16384	ERW
14.5.7	4412	Word bit6 src		LINK	16	6000	0	16384	ERW
14.5.8	4414	Word bit7 src		LINK	16	6000	0	16384	ERW
14.5.9	4416	Word bit8 src		LINK	16	6000	0	16384	ERW
14.5.10	4418	Word bit9 src		LINK	16	6000	0	16384	ERW
14.5.11	4420	Word bit10 src		LINK	16	6000	0	16384	ERW
14.5.12	4422	Word bit11 src		LINK	16	6000	0	16384	ERW
14.5.13	4424	Word bit12 src		LINK	16	6000	0	16384	ERW
14.5.14	4426	Word bit13 src		LINK	16	6000	0	16384	ERW
14.5.15	4428	Word bit14 src		LINK	16	6000	0	16384	ERW
14.5.16	4430	Word bit15 src		LINK	16	6000	0	16384	ERW

L_DIGSEL1

Selection of the origin (source) of the signal to be used for coding in **Word comp**. This function allows the user to compose a single word composed of 16 signals, each of which can be selected from among those listed in the “L_DIGSEL1” selection list. The values of the sectioned sizes are converted into a single word.

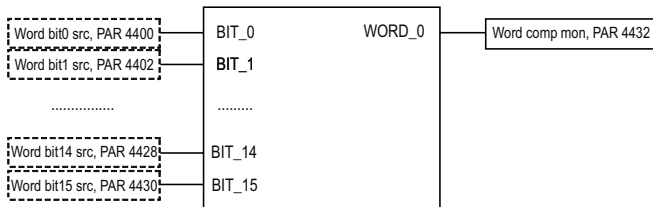

Menu	PAR	Description	UM	Type	FB BIT	Def	Min	Max	Acc
14.5.17	4432	Monitor word comp		UINT32	16	0	0	0	ER

The hexadecimal value of the **Word comp** output is displayed.

14.6 - COMMUNICATION/WORD DECOMP

Menu	PAR	Description	UM	Type	FB BIT	Def	Min	Max	Acc
14.6.1	4450	Dig word decomp		UINT32	16	0	0	0	ERW

Setting of the digital input decoded by the "Word decomp" block.

Menu	PAR	Description	UM	Type	FB BIT	Def	Min	Max	Acc
14.6.2	4452	Word decomp src		LINK	16	4450	0	16384	ERW

L_WDECOMP

Selection of the origin (source) of the word to be decoded by the "**Word decomp**" block. Each bit that is part of the word to be decoded is associated with the output channel of the "**Word decomp**" block. The variables that can be used for this function can be selected from among those listed in the "L_WDECOMP" selection list.

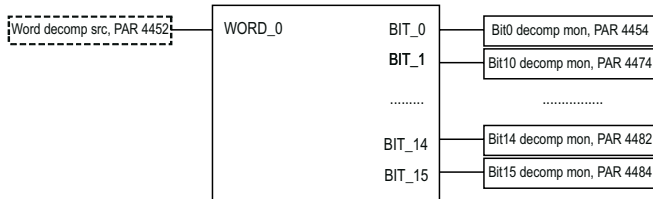

Menu	PAR	Description	UM	Type	FB BIT	Def	Min	Max	Acc
14.6.3	4454	Bit0 decomp mon		BIT	16	0	0	1	ER
14.6.4	4456	Bit1 decomp mon		BIT	16	0	0	1	ER
14.6.5	4458	Bit2 decomp mon		BIT	16	0	0	1	ER
14.6.6	4460	Bit3 decomp mon		BIT	16	0	0	1	ER
14.6.7	4462	Bit4 decomp mon		BIT	16	0	0	1	ER
14.6.8	4464	Bit5 decomp mon		BIT	16	0	0	1	ER
14.6.9	4466	Bit6 decomp mon		BIT	16	0	0	1	ER
14.6.10	4468	Bit7 decomp mon		BIT	16	0	0	1	ER
14.6.11	4470	Bit8 decomp mon		BIT	16	0	0	1	ER
14.6.12	4472	Bit9 decomp mon		BIT	16	0	0	1	ER
14.6.13	4474	Bit10 decomp mon		BIT	16	0	0	1	ER
14.6.14	4476	Bit11 decomp mon		BIT	16	0	0	1	ER
14.6.15	4478	Bit12 decomp mon		BIT	16	0	0	1	ER
14.6.16	4480	Bit13 decomp mon		BIT	16	0	0	1	ER
14.6.17	4482	Bit14 decomp mon		BIT	16	0	0	1	ER
14.6.18	4484	Bit15 decomp mon		BIT	16	0	0	1	ER

The single bits that make up the selected word are displayed.

14.7 - COMMUNICATION/EXTERNAL IO

The optional EXP-FL-XCAN-ADV card (generally inserted in slot 1) allows the number of I/Os managed by the drive to be increased, using an external device. Communication with the external device is performed via CAN using the "DS401 Device profile for generic IO modules".

For more details see manual 1S5F32_EXP-FL-XCAN-ADV.

Menu	PAR	Description	UM	Type	FB BIT	Def	Min	Max	Acc
14.7.1	5480	External IO enable		ENUM		Disable	0	1	ERW

This parameter is used to enable or disable communication between the EXP-FL-XCAN-ADV card and the external device.

- 0 Disable
- 1 Enable

Communication is disabled in the default configuration. Communication can be enabled by setting Enable and saving the parameters. When the drive is re-started the EXP-FL-XCAN-ADV card, if installed, is recognised. The communication is started and the external I/Os are managed. With the "External IO enable" set to Disable the EXP-D6A4R1-ADV can be managed, if installed.

Menu	PAR	Description	UM	Type	FB BIT	Def	Min	Max	Acc
14.7.2	5482	External IO info		UINT32		0	0	4294967295	ER

This parameter displays the number of I/O resources read by the module.

It is a 32-bit parameter made up as follows:

Uint32			
Uint16 High		Uint16 Low	
Uint8 High	Uint8 Low	Uint8 High	Uint8 Low
N. of AO	N. of AI	N. of DO	N. of DI

The parameter is displayed in HEX format.

E.g.:

PAR 5482	N. of AO	N. of AI	N. of DO	N. of DI
0x02041020 33820704	0x02 2	0x04 4	0x10 16	0x20 32
0x00000810 2064	0x00 0	0x00 0	0x08 8	0x10 16

If the configuration that is read has changed (compared to the last configuration saved or read) the drive displays and message requires the intervention of the operator in order to proceed.

Menu	PAR	Description	UM	Type	FB BIT	Def	Min	Max	Acc
14.7.3	5484	External IO state		BIT	16BIT	0	0	1	ER

This parameter displays the communication state.

- 0 Off
- 1 On

This parameter is set to 1 (on) if the communication state is operational.

Menu	PAR	Description	UM	Type	FB BIT	Def	Min	Max	Acc
14.7.4	5486	External IO failcode		UINT32		0	0	4294967295	ER

If an "Ext I/O fault" occurs due to the Emergency slave subcode 255..65535 alarm message, this parameter displays 4 of the 5 InfoBytes of the "Emergency" message. See the slave manual for information about the meaning of the InfoBytes in the Emergency message (CAN slave communication module).

See paragraph **"9.1.1 "ExtI/O fault" Alarm" on page 163.**

14.8 - COMMUNICATION/FAST LINK

The optional EXP-FL-XCAN-ADV card (generally inserted in slot 1) allows the number of I/Os managed by the drive to be increased, using an external device. Communication with the external device is performed via CAN using the "DS401 Device profile for generic IO modules".

For more details see manual 1S5F32_EXP-FL-XCAN-ADV.

Menu	PAR	Description	UM	Type	FB BIT	Def	Min	Max	Acc
14.8.1	5702	FL address		UINT16		0	0	16	ERWZ

This parameter is used to enable the FastLink function and select whether the drive is to be the master or slave. If used as a slave device, the address can be selected.

- 0 = Disabled
- 1 = Master
- 2 = Slave 1
- X = Slave X-1
- 16 = Slave 16

For the Pwm synchronisation to function properly, the address of the slave drive must be configured in the same order as the physical connection.

Menu	PAR	Description	UM	Type	FB BIT	Def	Min	Max	Acc
14.8.2	5818	FL bidirectional		ENUM		Enable	0	1	ERWZ

Enables/disables bi-directional Fast Link mode.

- 0 Disable
- 1 Enable

Menu	PAR	Description	UM	Type	FB BIT	Def	Min	Max	Acc
14.8.3	5820	FL N of slave		UINT16		0	0	32767	ERWZ

It is a parameter related only to the master drive and it indicates which slave drives need to be interrogated.

The encoding data used is an integer having set to 1 the bit corresponding to the slaves that need to be interrogated:

- bit 0 (least significant bit) is related to slave with address 2
- bit 1 is related to the slave with address 3
- ...
- ...until to the slave with address 16.

For example, if need to be interrogated slaves with address 2 and address 5, the value will be 9 (1001 binary). If one or more slaves are not connected to the drops giving no answer, it will produce a fast link alarm on the master drive. Fast link alarm on the master will produce communication error to all the slaves connected.

Menu	PAR	Description	UM	Type	FB BIT	Def	Min	Max	Acc
14.8.4	5710	FL sync slave type		ENUM		Off	0	2	ERWZ

This parameter is ineffective on the master drive.

On the slave drive this parameter is used to enable the function for generating Pwm signals that are synchronised with the Pwm signals of the master. It is also possible to enable the function for executing control tasks synchronised with execution of control tasks of the master.

- 0 Off Fastlink transfers information between the drives.

- 1 Pwm The Fastlink transfers information between the drives and the function for synchronising the generation of Pwm signals with the Pwm signals of the master is enabled. The variables in the 11) Updating times for the various functions table are synchronised at 125 us
- 2 Pwm&Ctrl The Fastlink transfers information between the drives, the function for synchronising the generation of Pwm signals with the Pwm signals of the master is enabled and the function for synchronising control tasks with the control tasks of the master is enabled. The variables in table “Updating times for the various functions” (on manual 1S5F32_EXP-FL-XCAN-ADV) and the MDPLC tasks are also synchronised to 1 ms and 8 ms.

Menu	PAR	Description	UM	Type	FB BIT	Def	Min	Max	Acc
14.8.5	5712	FL N Fwd slave chg		UINT16		0	0	4	ERWZ

There are two possible operation modes.

In the first, the master sends the data frame to the first slave. The first slave takes all the data in the frame and sends the same frame to the next slave without making any changes. The same sequence is repeated by all the slave drives.

In the second, the master sends the data frame to the first slave. The first slave takes all the data in the frame, replaces part of the data and then sends the frame to the next slave drive. The same sequence is repeated by all the slave drives.

This parameter is ineffective on the master drive.

On the slave drive this parameter is used to configure the amount of data to be replaced in the data frame.

FL N Fw slave change	Information replaced
0	None
1	FL Fw 1
2	FL Fw 1, FL Fw 2
3	FL Fw 1, FL Fw 2, FL Fw 3
4	FL Fw 1, FL Fw 2, FL Fw 3, FL Fw 4

Menu	PAR	Description	UM	Type	FB BIT	Def	Min	Max	Acc
14.8.6	5714	FL fault enable src		LINK	16BIT	6002	0	16384	ERW

L_DIGSEL1

This parameter is used to select the origin (source) of the FL fault enable signal.

The signal to be associated with this function can be selected from the “L_DIGSEL1” selection list.

0 FL fault enable not active (No FastLink alarm signal)

1 FL fault enable active (FastLink alarm signal)

When the drive detects a FastLink fault, it prepares to trigger a “**FastLink fault**” alarm. This command is used to select whether an alarm is generated when a fault is detected.

Alarm generation is enabled in the default configuration.

The configuration of the “**FL fault enable src**” parameter can be changed to control the phases in which alarm generation is enabled.

For example, by connecting the “**FL fault enable src**” parameter to “**Enable state mon**” you can enable generation of the “FastLink fault” alarm in the phase when the drive is enabled.

In systems where drive the drives are not powered-off simultaneously, some drives detect a FastLink fault and generate a FastLink alarm.

This parameter is used to disable the alarm at power-off by connecting the “**FL fault enable src**” parameter to “**Enable state mon**”.

Menu	PAR	Description	UM	Type	FB BIT	Def	Min	Max	Acc
14.8.7	5730	FL Fwd 1 src		LINK	16/32BIT	6000	0	16384	ERW
14.8.8	5732	FL Fwd 2 src		LINK	16/32BIT	6000	0	16384	ERW
14.8.9	5734	FL Fwd 3 src		LINK	16/32BIT	6000	0	16384	ERW
14.8.10	5736	FL Fwd 4 src		LINK	16/32BIT	6000	0	16384	ERW

L_FLWORD

This parameter is used to select the origin (source) of the **FL Fw 1 src** signal.

The signal to be associated with this function can be selected from the “L_FLWORD” selection list.

On the drive configured as the master, these parameters are used to select the data to be sent to the first slave.

On drives configured as slaves, these parameters are used to select the data that the slave must include in the data frame to replace the data received from the previous drive.

Replacement is disabled in the default configuration. It can be enabled with the PAR 5712 “**FL N Fwd slave chg**” parameter.

Menu	PAR	Description	UM	Type	FB BIT	Def	Min	Max	Acc
14.8.11	5830	FL Rev 1 src		LINK	16/32BIT	6000	0	16384	ERW
14.8.12	5832	FL Rev 2 src		LINK	16/32BIT	6000	0	16384	ERW

L_FLWORD

Parameter significant only for Slave drive, indicates what data to insert in first word to be sent to Master drive when Slave is interrogated. Selectable values are shown on the L_FLWORD list.

Menu	PAR	Description	UM	Type	FB BIT	Def	Min	Max	Acc
14.8.13	5750	FL Fwd 1 mon		INT32	32BIT	0	0	0	ER
14.8.14	5752	FL Fwd 2 mon		INT32	32BIT	0	0	0	ER
14.8.15	5754	FL Fwd 3 mon		INT32	32BIT	0	0	0	ER
14.8.16	5756	FL Fwd 4 mon		INT32	32BIT	0	0	0	ER
14.8.17	5758	FL Fwd 5 mon		INT32	32BIT	0	0	0	ER
14.8.18	5760	FL Fwd 6 mon		INT32	32BIT	0	0	0	ER
14.8.19	5762	FL Fwd 7 mon		INT32	32BIT	0	0	0	ER
14.8.20	5764	FL Fwd 8 mon		INT32	32BIT	0	0	0	ER

These parameters are not used on the master drive.

On the slave drive these parameters show the value received from the previous drive.

The “Inv” parameters enable the value received to be used with the opposite sign, without changing any of the data sent to subsequent slaves.

These parameters are available in the src analog parameter selection lists.

Menu	PAR	Description	UM	Type	FB BIT	Def	Min	Max	Acc
14.8.21	5850	FL Rev 1 mon		INT32	32BIT	0	0	0	ER
14.8.22	5852	FL Rev 2 mon		INT32	32BIT	0	0	0	ER
14.8.23	5854	FL Rev 3 mon		INT32	32BIT	0	0	0	ER

14.8.24 5856 FL Rev 4 mon INT32 32BIT 0 0 0 ER

Display of data selected via parameters **FL Rev X Slave sel** corresponding (PAR 5822 ... 5828).

Menu	PAR	Description	UM	Type	FB BIT	Def	Min	Max	Acc
14.8.25	5822	FL Rev 1 slave sel		UJINT16		0	0	31	ERWZ
14.8.26	5824	FL Rev 2 slave sel		UJINT16		0	0	31	ERWZ
14.8.27	5826	FL Rev 3 slave sel		UJINT16		0	0	31	ERWZ
14.8.28	5828	FL Rev 4 slave sel		UJINT16		0	0	31	ERWZ

Parameter significant only for Master drive, indicates what data of which Slave drive to display in parameter **FL Rev X mon** (you can choose to display word 1 or 2 of a Slave with address from 2 to 16). The code used assigns the significance of the first word of the Slave at address 2 to value 0, value 1 for the first word of the Slave at address 3 14 first word of the Slave at address 16, 15 has no significance, 16 second word of Slave at address 2 ... 30 second word of Slave at address 16.

Menu	PAR	Description	UM	Type	FB BIT	Def	Min	Max	Acc
14.8.29	5720	Sync slave mon		BIT	16BIT	0	0	1	ER

This parameter is not significant on the master drive.

On the slave drives this parameter indicates the state of the function that enables Pwm signals to be synchronised with the Pwm signals of the master and execution of control tasks to be synchronised with execution of control tasks of the master.

- 0 Slave not synchronised
- 1 Slave synchronised

Menu	PAR	Description	UM	Type	FB BIT	Def	Min	Max	Acc
14.8.30	5722	FL fault code		UJINT32		0	0	0	ER

This parameter is used to display the cause of the **FastLink fault** alarm.

See paragraph ["9.1.2 "Fastlink fault" Alarm" on page 164.](#)

15 - ALARM CONFIG

In the ALARM CONFIG menu the type of effect any alarm signals have on the AFE product is determined:

- The alarm status is saved
- How must the AFE product react to the alarm signal?
- Auto restart
- Alarm reset

For some alarms, behaviour can be configured separately for each signal, while for the others the Disable AFE product is executed. Individual signals can also be sent to a programmable digital output.

Activity	Ignore	The alarm is not included in the list of alarms, it is not included in the alarm log, it is not signalled on the digital outputs, no AFE product commands are modified.
	Warning	The alarm is included in the list of alarms, it is included in the alarm log, it is signalled on the digital outputs, the First alarm information is updated, the Alarm enabled information is updated, no AFE product commands are modified.
	Disable drive	The alarm is inserted in the alarm list, it is inserted in the alarm log, it is signalled on the digital outputs, the First alarm data is updated, the Alarm active data is updated, the AFE product is disabled.

n alarms with Activity = Ignore or Warning can be enabled at the same time.

If an alarm with Activity = Stop or Fast Stop is enabled and another alarm with an Activity other than Ignore or Warning is enabled, the AFE product stops and is disabled

Not all alarms allow the controlled stopping of the AFE product. The following table shows the possibility of setting the Activities for the individual alarm signals.

Alarm	PAR	Ignore	Warning	Disable drive
ExtFlt activity	4504	√	√	√
ExtFlt restart	4506	-	-	√
UndervoltAC activity	4534	√	√	√
UndervoltAC restart	4536	-	-	√
Overvolt AC activity	4554	√	√	√
Overvolt AC restart	4556	-	-	√
Drive ovld activity	4570	√	√	√
HTsens restart	4582	-	-	√
InAir activity	4600	√	√	√
InAir restart	4602	-	-	√
Desat restart	4610	-	-	√
IOverC restart	4620	-	-	√
OverV restart	4630	-	-	√
UnderV restart	4640	-	-	√
Optionbus activity	4670	√	√	√

Alarm	PAR	Ignore	Warning	Disable drive
ExtIO activity	4690	√	√	√
FL fault activity	4940	√	√	√

Menu	PAR	Description	UM	Type	FB BIT	Def	Min	Max	Acc
15.1	4500	Fault reset src		LINK	16BIT	1120	0	16384	RW

DIGSEL2

Selection of the origin (source) of the signal to be used for the command to reset the AFE product after an alarm. The terminal that can be used for this function can be selected from among those listed in the “L_DIGSEL2” selection list.

Menu	PAR	Description	UM	Type	FB BIT	Def	Min	Max	Acc
15.2	4502	ExtFlt src		LINK	16BIT	6000	0	16384	RW

DIGSEL2

Selection of the origin (source) of the signal to be used as the input for the AFE product **External Fault [20]** alarm. The terminal that can be used for this function can be selected from among those listed in the “L_DIGSEL2” selection list.

Menu	PAR	Description	UM	Type	FB BIT	Def	Min	Max	Acc
15.3	4498	Precharge fbk src		LINK	16BIT	1112	0	16384	RW

L_DIGSEL1

Setting of the origin for the signal to confirm the pre-load contactor. If no confirmation is received after a 100ms hold-off time the **Prc fbk loss [23]** alarm is generated (Pre-load not confirmed).

If this parameter is set to **Precharge Command** (PAR 1122) the command and confirmation always correspond and the alarm signal is never activated.

Starting from AFE with FW version 7.1.X this command is no more used with precharge kit.

Menu	PAR	Description	UM	Type	FB BIT	Def	Min	Max	Acc
15.4	4504	ExtFlt activity		ENUM		Disable	0	2	RW

Setting of the behaviour of the AFE product in the event of an external fault alarm **External Fault [20]**. This alarm indicates the intervention of a AFE product external protection.

- 0 Ignore
- 1 Warning
- 2 Disable

Menu	PAR	Description	UM	Type	FB BIT	Def	Min	Max	Acc
15.5	4506	ExtFlt restart		ENUM		Disabilita	0	1	RW

Enabling of automatic restart after the external fault alarm **External Fault [20]**

- 0 Disable
- 1 Enable

Menu	PAR	Description	UM	Type	FB BIT	Def	Min	Max	Acc
15.6	4508	ExtFlt restart time	ms	UINT16		1000	120	30000	RW

Setting of the time within which the **External Fault [20]** alarm must be reset in order to perform automatic restart.

Menu	PAR	Description	UM	Type	FB BIT	Def	Min	Max	Acc
15.7	4510	ExtFlt holdoff	ms	UINT16		0	0	10000	RW

Setting of the delay between the signalling of the **External Fault [20]** alarm and enabling of the alarm. If an alarm condition occurs, the AFE product will wait for the set time to activate the alarm. If the alarm is removed within the set time, the AFE product will not indicate any alarm condition.

Menu	PAR	Description	UM	Type	FB BIT	Def	Min	Max	Acc
15.8	4534	UndervoltAC activity		ENUM		Disable	0	2	RW

Setting of the behaviour of the AFE product if the **Undervolt AC [9]** alarm is present. This alarm indicates a mains undervoltage condition.

- 0 Ignore
- 1 Warning
- 2 Disable

Menu	PAR	Description	UM	Type	FB BIT	Def	Min	Max	Acc
15.9	4536	UndervoltAC restart		ENUM		Disable	0	1	RW

Setting of the behaviour of the AFE product if the **Undervolt AC [9]** alarm is present. This alarm indicates a mains undervoltage condition.

- 0 Disable
- 1 Enable

Menu	PAR	Description	UM	Type	FB BIT	Def	Min	Max	Acc
15.10	4538	UndervoltAC restarttime	ms	UINT16		1000	0	30000	RW

Setting of the time within which the **Undervolt AC [9]** alarm must be removed in order to execute automatic restart.

Menu	PAR	Description	UM	Type	FB BIT	Def	Min	Max	Acc
15.11	4554	Overvolt AC activity		ENUM		Disable	0	2	RW

Setting of the behaviour of the AFE product if the **Overvoltage AC [10]** alarm is present. This alarm indicates a mains voltage overvoltage condition.

- 0 Ignore
- 1 Warning
- 2 Disable

Menu	PAR	Description	UM	Type	FB BIT	Def	Min	Max	Acc
15.12	4556	Overvolt AC restart		ENUM		Disable	0	1	RW

Enabling of automatic restart after the **Overvoltage AC [10]** alarm.

- 0 Disable
- 1 Enable

Menu	PAR	Description	UM	Type	FB BIT	Def	Min	Max	Acc
15.13	4558	OverVAC restart time	ms	UINT16		1000	0	30000	RW

Setting of the time within which the **Undervolt AC [9]** alarm must be removed in order to execute automatic restart.

Menu	PAR	Description	UM	Type	FB BIT	Def	Min	Max	Acc
15.14	4570	Drive ovl'd activity		ENUM		Ignore	0	2	ERW
Setting of the behaviour of the AFE product in case of a Drive overload [14] alarm. This alarm indicates that the AFE product overload threshold has been reached.									
<ul style="list-style-type: none"> 0 Ignore 1 Warning 2 Disable 									

Menu	PAR	Description	UM	Type	FB BIT	Def	Min	Max	Acc
15.15	4582	HTsens restart		ENUM		Disable	0	1	ERW
Enabling of automatic restart after the AFE product heatsink overtemperature alarm Heatsinks OTUT [12] .									
<ul style="list-style-type: none"> 0 Disable 1 Enable 									

Menu	PAR	Description	UM	Type	FB BIT	Def	Min	Max	Acc
15.16	4584	HTsens restart time	ms	UINT16		20000	120	60000	ERW
Setting of the time within which the Heatsinks OTUT [12] alarm must be reset in order to perform automatic restart.									

Menu	PAR	Description	UM	Type	FB BIT	Def	Min	Max	Acc
15.17	4600	InAir activity		ENUM		Disable	0	2	ERW
Setting of the behaviour of the AFE product in case of an intake air overtemperature alarm InAir [13] . This alarm indicates that the temperature of the intake cooling air is too high.									
<ul style="list-style-type: none"> 0 Ignore 1 Warning 2 Disable 									

Menu	PAR	Description	UM	Type	FB BIT	Def	Min	Max	Acc
15.18	4602	InAir restart		ENUM		Disable	0	1	ERW
Enabling of automatic restart after the Intakeair OT [13] overtemperature alarm.									
<ul style="list-style-type: none"> 0 Disable 1 Enable 									

Menu	PAR	Description	UM	Type	FB BIT	Def	Min	Max	Acc
15.19	4604	InAir restart time	ms	UINT16		1000	120	30000	ERW
Setting of the time within which the Intakeair OT [13] alarm must be reset in order to perform automatic restart.									

Menu	PAR	Description	UM	Type	FB BIT	Def	Min	Max	Acc
15.20	4606	Air holdoff	ms	UINT16		10000	0	30000	ERW
Setting of the delay between the signalling of the Intakeair OT [13] overtemperature alarm and enabling of the alarm. If an alarm condition occurs, the AFE product will wait for the set time before enabling the alarm. If the alarm is removed within the set time, the AFE product will not indicate any alarm condition.									

Menu	PAR	Description	UM	Type	FB BIT	Def	Min	Max	Acc
15.21	4610	Desat restart		ENUM		Disable	0	1	ERW
		Enabling of automatic restart after the desaturation alarm Desaturation [5] . This alarm indicates a short circuit between the phases of the power bridge.							
		0	Disable						
		1	Enable						
Menu	PAR	Description	UM	Type	FB BIT	Def	Min	Max	Acc
15.22	4612	Desat restart time	ms	UINT16		2000	1000	10000	ERW
		Setting of the time within which the Desaturation [5] alarm must be reset in order to perform automatic restart. (Time with alarm signal active + 1000 msec).							
Menu	PAR	Description	UM	Type	FB BIT	Def	Min	Max	Acc
15.23	4620	IOVerC restart		ENUM		Disable	0	1	ERW
		Enabling of automatic restart after the AFE product Overcurrent [4] alarm. This alarm indicates an overcurrent (or short circuit between phases or towards the ground).							
		0	Disable						
		1	Enable						
Menu	PAR	Description	UM	Type	FB BIT	Def	Min	Max	Acc
15.24	4622	IOVerC restart time	ms	UINT16		2000	1000	10000	ERW
		Setting of the time within which the Overcurrent [4] alarm must be reset in order to perform automatic restart. (Time with alarm signal active + 1000 msec).							
Menu	PAR	Description	UM	Type	FB BIT	Def	Min	Max	Acc
15.25	4630	OverV restart		ENUM		Disable	0	1	ERW
		Enabling of automatic restart after the Overvoltage [1] alarm. This alarm indicates an overvoltage on the intermediate circuit (DC link)							
		0	Disable						
		1	Enable						
Menu	PAR	Description	UM	Type	FB BIT	Def	Min	Max	Acc
15.26	4632	OverV restart time	ms	UINT16		2000	1000	10000	ERW
		Setting of the time within which the Overvoltage [1] alarm must be reset in order to perform automatic restart. (Time with alarm signal active + 1000 msec).							
Menu	PAR	Description	UM	Type	FB BIT	Def	Min	Max	Acc
15.27	4640	UnderV restart		ENUM		Enable	0	1	ERW
		Enabling of automatic restart after the Undervoltage [2] alarm. This alarm indicates an undervoltage on the intermediate circuit (DC link)							
		0	Disable						
		1	Enable						
Menu	PAR	Description	UM	Type	FB BIT	Def	Min	Max	Acc
15.28	4642	UnderV restart time	ms	UINT16		1000	120	10000	ERW

Setting of the time within which the **Undervoltage [2]** alarm must be reset in order to perform automatic restart. (Time with alarm signal active + 100 msec).

Menu	PAR	Description	UM	Type	FB BIT	Def	Min	Max	Acc
15.29	4650	UVRep attempts		UINT16		5	0	1000	ERW

Setting of the maximum number of attempts at automatic restart after the **Undervoltage [2]** alarm before a **Mult Undervoltage [6]** alarm is generated. If this parameter is set to 1000 an infinite number of attempts are available.

Menu	PAR	Description	UM	Type	FB BIT	Def	Min	Max	Acc
15.30	4652	UVRep delay	s	UINT16		240	0	300	ERW

Setting of the time within which, if no automatic restarts are executed after the **Undervoltage [2]** alarm, the attempts counter is reset. In this way the number of attempts set in **UVRep attempt** are still available.

Menu	PAR	Description	UM	Type	FB BIT	Def	Min	Max	Acc
15.31	4670	Optionbus activity		ENUM		Disable	0	2	ERW

Setting of the behaviour of the AFE product in case of an **Opt Bus Fault [16]** alarm.

- 0 Ignore
- 1 Warning
- 2 Disable

Menu	PAR	Description	UM	Type	FB BIT	Def	Min	Max	Acc
15.32	4690	ExtIO activity		ENUM		Disable	0	2	ERW

This parameter is used to configure the behaviour of the drive if the **“Ext I/O fault” [27]** alarm occurs when the EXP-FL-XCAN-ADV card is installed.

See Chapter 9 - **“Ext I/O fault” [27]** alarm.

When the alarm is activated due to a communication error, the last value that was received is maintained.

The following activities are programmable:

- 0 Ignore
- 1 Warning
- 2 Disable

You can check whether a card that supports XCAN External IO functions is installed from the DRIVE INFO menu for parameters 530, 532, 534 SlotX card type:

Value	Description	Expansion	
832	IO FastLink	EXP-FL-XCAN-ADV	XCAN External IO supported

Menu	PAR	Description	UM	Type	FB BIT	Def	Min	Max	Acc
15.33	4940	FL fault activity		ENUM		Disable	0	2	ERW

This parameter is used to configure the behaviour of the drive when the **“FastLink fault” [28]** alarm occurs.

If the EXP-FL-XCAN-ADV card is installed in the drive, all the FastLink communication fault signals are enabled and managed via generation of a **“FastLink fault” [28]** alarm, with different subcodes to indicate the cause of the error.

See Chapter 9 - **“FastLink Fault” [28]** alarm.

The following activities are programmable:

- 0 Ignore
- 1 Warning
- 2 Disable

Menu	PAR	Description	UM	Type	FB BIT	Def	Min	Max	Acc
15.34	4680	GroundFault thr	perc	FLOAT		10.0	0.0	150.0	ERWS

Setting of the threshold for the ground short circuit alarm **Ground Fault [3]**.

Menu	PAR	Description	UM	Type	FB BIT	Def	Min	Max	Acc
15.35	4700	Alarm dig sel 1		ENUM		No alarm	0	60	ERW
15.36	4702	Alarm dig sel 2		ENUM		No alarm	0	60	ERW
15.37	4704	Alarm dig sel 3		ENUM		No alarm	0	60	ERW
15.38	4706	Alarm dig sel 4		ENUM		No alarm	0	60	ERW

Setting of the alarm signal to enable on a digital output. The digital output is selected using parameters **Alm dig out mon 1-4**, which can be enabled in the L_DIGSEL1 selection list.

- 0 No alarm
- 1 Overvoltage
- 2 Undervoltage
- 3 Ground fault
- 4 Overcurrent
- 5 Desaturation
- 6 MultiUndervolt
- 7 MultiOvercurr
- 8 MultiDesat
- 9 Undervolt AC
- 10 Overvoltage AC
- 11 Heatsink OT
- 12 HeatsinkS OTUT
- 13 Intakeair OT
- 14 Drive overload
- 15 Bres overload
- 16 Opt Bus fault
- 17 Opt 1 IO fault
- 18 Opt 2 IO fault
- 19 Opt Enc fault
- 20 External fault
- 21 Emg stop alarm
- 22 Power down
- 23 Prc fbk loss
- 24 Not Used1
- 25 Not Used2
- 26 Not Used3
- 27 ExtIO fault
- 28 FastLink fault
- 29 Not Used6
- 30 Not Used7
- 31 Not Used8
- 32 Not Used9
- 33 Plc1 fault
- 34 Plc2 fault
- 35 Plc3 fault
- 36 Plc4 fault
- 37 Plc5 fault
- 38 Plc6 fault

- 39 Plc7 fault
- 40 Plc8 fault

Menu	PAR	Description	UM	Type	FB BIT	Def	Min	Max	Acc
15.39	4720	Alm autoreset time	s	FLOAT		0.0	0.0	60.0	ERW
<p>Setting of the time interval that must pass before executing an automatic reset. If no alarms are enabled the AFE product is set to restart. If some alarms are still enabled the AFE product is set to execute a new attempt at automatic reset. At each attempted reset a counter increases. If the limit set in the PAR 4722 Alm autoreset number parameter is reached the AFE product is set to make no more attempts at reset and waits for a user reset. The counter is set to zero when an automatic reset or user reset is performed and no alarms are enabled. If the parameter is 0 the function is disabled.</p>									
15.40	4722	Alm autoreset number		UINT16		20	0	100	ERW
<p>Setting of the maximum number of attempted automatic resets.</p>									

16 - ALARM LOG

This is the menu in which the log of previous alarms is saved, with the time the alarm occurred (in relation to the **Time drive power on** parameter).

The alarms are displayed starting from the most recent (No. 1) up to the furthest back in time (No. 30).

Up to 30 alarm signals can be displayed. The sub-code is used by service technicians to identify the specific type of alarm.

Press the ▲ and ▼ keys to scroll the screen pages of the alarm log. The alarm log cannot be deleted.

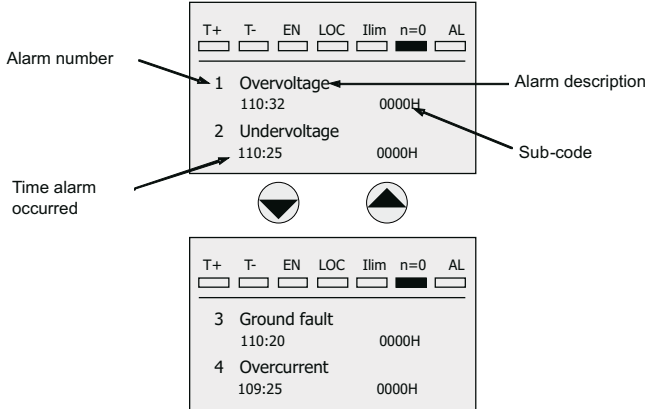

17 - PLC LOG

Reserved for AFE200-PV.

18 - APPLICATION

This menu is designed to host two customized applications using the MDPIc program, currently in progress. It will not be possible to use both applications simultaneously. PAR 558 **Application select** parameter in the DRIVE CONFIG menu must be used to select between the two possible applications.

8.1 Parameters on selection lists, but not displayed on keypad

Menu	PAR	Description	UM	Type	FB BIT	Def	Min	Max	Acc
-	362	Drive overload trip		BIT	16BIT	0	0	1	ER

This signal indicates that the AFE product is in the overload alarm condition.

Menu	PAR	Description	UM	Type	FB BIT	Def	Min	Max	Acc
-	366	Drive overload 80%		BIT	16BIT	0	0	1	ER

This signal indicates that the AFE product has reached 80% of the thermal image accumulator (Drive overload).

Menu	PAR	Description	UM	Type	FB BIT	Def	Min	Max	Acc
-	1030	Local/remote mon		BIT	16BIT	0	0	1	ER

This signal is active when the AFE product is in the Remote operating mode.

0 Local
1 Remote

Menu	PAR	Description	UM	Type	FB BIT	Def	Min	Max	Acc
-	1062	Drive OK		BIT	16BIT	0	0	1	ER

This signal is active when the AFE product is in the "OK" condition and no alarms are present.

Menu	PAR	Description	UM	Type	FB BIT	Def	Min	Max	Acc
-	1064	Drive ready		BIT	16BIT	0	0	1	ER

This signal is active when the AFE product reference is in the "Ready" to run condition.

Menu	PAR	Description	UM	Type	FB BIT	Def	Min	Max	Acc
-	1068	Enable ready mon		BIT	16BIT	0	0	1	ER

This signal is active when the AFE can accept the enable command. If the enable command is sent before PAR 1068 **Enable ready mon** is active, it is not accepted.

Menu	PAR	Description	UM	Type	FB BIT	Def	Min	Max	Acc
-	1110	Digital input E mon		BIT	16BIT	0	0	1	ER
-	1112	Digital input 1 mon		BIT	16BIT	0	0	1	ER
-	1114	Digital input 2 mon		BIT	16BIT	0	0	1	ER
-	1116	Digital input 3 mon		BIT	16BIT	0	0	1	ER
-	1118	Digital input 4 mon		BIT	16BIT	0	0	1	ER
-	1120	Digital input 5 mon		BIT	16BIT	0	0	1	ER

These signals represent the state of the corresponding digital input.

Menu	PAR	Description	UM	Type	FB BIT	Def	Min	Max	Acc
-	1122	Precharge Command		BIT	16BIT	0	0	1	ER

This signal is enabled when the voltage on the DC-link exceeds the set value and indicates the end of pre-loading. It is used to close the main contactor and open the pre-load resistor contactor (for version fw 7.0 and lower).

Menu	PAR	Description	UM	Type	FB BIT	Def	Min	Max	Acc
-	1210	Digital input 1X mon		BIT	16BIT	0	0	1	ER
-	1212	Digital input 2X mon		BIT	16BIT	0	0	1	ER
-	1214	Digital input 3X mon		BIT	16BIT	0	0	1	ER
-	1216	Digital input 4X mon		BIT	16BIT	0	0	1	ER
-	1218	Digital input 5X mon		BIT	16BIT	0	0	1	ER
-	1220	Digital input 6X mon		BIT	16BIT	0	0	1	ER
-	1222	Digital input 7X mon		BIT	16BIT	0	0	1	ER
-	1224	Digital input 8X mon		BIT	16BIT	0	0	1	ER
-	5510	Digital input 9X mon		BIT	16BIT	0	0	1	ER
-	5512	Digital input 10X mon		BIT	16BIT	0	0	1	ER
-	5514	Digital input 11X mon		BIT	16BIT	0	0	1	ER
-	5516	Digital input 12X mon		BIT	16BIT	0	0	1	ER
-	5518	Digital input 13X mon		BIT	16BIT	0	0	1	ER
-	5520	Digital input 14X mon		BIT	16BIT	0	0	1	ER
-	5522	Digital input 15X mon		BIT	16BIT	0	0	1	ER
-	5524	Digital input 16X mon		BIT	16BIT	0	0	1	ER

These signals represent the state of the corresponding digital input on the expansion card.

Menu	PAR	Description	UM	Type	FB BIT	Def	Min	Max	Acc
-	1530	Analog inp1		BIT	16BIT	0	0	1	ER

This signal is active when the value of the analog input is below the threshold set in parameter **1520 Analog inp 1 thr**

Menu	PAR	Description	UM	Type	FB BIT	Def	Min	Max	Acc
-	1580	Analog inp2		BIT	16BIT	0	0	1	ER

This signal is active when the value of the analog input is below the threshold set in parameter **1570 Analog inp 2 thr**.

Menu	PAR	Description	UM	Type	FB BIT	Def	Min	Max	Acc
-	2388	Active curr noflt	A	FLOAT	16BIT	0.0	0.0	0.0	ER

The active current reference is displayed without filter.

Menu	PAR	Description	UM	Type	FB BIT	Def	Min	Max	Acc
-	3260	Bres overload accum	perc	UINT16	16BIT	0	0	100	ER

The braking resistor overload limit is displayed (100% = alarm threshold). This parameter is not available for the standard version of the AFE200.

Menu	PAR	Description	UM	Type	FB BIT	Def	Min	Max	Acc
-	4708	Alm dig out mon 1		BIT	16BIT	0	0	1	ER

This signal is activated when the alarm configured in parameter **4700 alarm dig sel 1** is active.

Menu	PAR	Description	UM	Type	FB BIT	Def	Min	Max	Acc
-	4710	Alm dig out mon 2		BIT	16BIT	0	0	1	ER

This signal is activated when the alarm configured in parameter **4702 alarm dig sel 2** is active.

Menu	PAR	Description	UM	Type	FB BIT	Def	Min	Max	Acc
-	4712	Alm dig out mon 3		BIT	16BIT	0	0	1	ER
<p>This signal is activated when the alarm configured in parameter 4704 alarm dig sel 3 is active.</p>									

Menu	PAR	Description	UM	Type	FB BIT	Def	Min	Max	Acc
-	4714	Alm dig out mon 4		BIT	16BIT	0	0	1	ER
<p>This signal is activated when the alarm configured in parameter 4706 alarm dig sel 4 is active.</p>									

Menu	PAR	Description	UM	Type	FB BIT	Def	Min	Max	Acc
-	4770	First alarm		UINT32	16BIT	0	0	0	ERW
<p>This parameter displays the first alarm to be activated.</p>									

- 0 No alarm
- 1 Overvoltage
- 2 Undervoltage
- 3 Ground fault
- 4 Overcurrent
- 5 Desaturation
- 6 MultiUndervolt
- 7 MultiOvercurr
- 8 MultiDesat
- 9 Undervolt AC
- 10 Overvoltage AC
- 11 Heatsink OT
- 12 HeatsinkS OTUT
- 13 Intakeair OT
- 14 Drive overload
- 15 Bres overload
- 16 Opt Bus fault
- 17 Opt 1 IO fault
- 18 Opt 2 IO fault
- 19 Opt Enc fault
- 20 External fault
- 21 Emg stop alarm
- 22 Power down
- 23 Prc fbk loss
- 24 Not Used1
- 25 Not Used2
- 26 Not Used3
- 27 ExtIO fault
- 28 FastLink fault
- 29 Not Used6
- 30 Not Used7
- 31 Not Used8
- 32 Not Used9
- 33 Plc1 fault
- 34 Plc2 fault
- 35 Plc3 fault
- 36 Plc4 fault
- 37 Plc5 fault
- 38 Plc6 fault
- 39 Plc7 fault
- 40 Plc8 fault

Menu	PAR	Description	UM	Type	FB BIT	Def	Min	Max	Acc
-	4780	Alarm PLC		UINT16		0	0	0	ER

This parameter displays the state of the alarms generated by the application written with the internal PLC

Bit	Description
0	1 = PLC 1 fault active
1	1 = PLC 2 fault active
2	1 = PLC 3 fault active
3	1 = PLC 4 fault active
4	1 = PLC 5 fault active
5	1 = PLC 6 fault active
6	1 = PLC 7 fault active
7	1 = PLC 8 fault active

Menu	PAR	Description	UM	Type	FB BIT	Def	Min	Max	Acc
-	4840	Alarm lo state		UINT32	32BIT	0	0	0	ER

This parameter displays the state of alarms 1..32 of the AFE product.

Bit	Description
0	1 = Overvoltage active
1	1 = Undervoltage active
2	1 = Ground fault active
3	1 = Overcurrent active
4	1 = Desaturation active
5	1 – MultiUndervolt active
6	1 = MultiOvercurr active
7	1 – MultiDesat active
8	1 = Heatsink OT active
9	1 = Heatsink lin OT active
10	1 = Air OT active
11	1 = Motor OT active
12	1 = Drive overload active
13	1 = Motor overload active
14	1 = Bres overload active
15	1 = Phase loss active
16	1 = Opt bus fault active
17	1 = Opt 1 I/O fault active
18	1 = Opt 2 I/O fault active
19	1 = Opt enc fault active
20	1 = External fault active
21	1 = Fbk loss active
22	1 = Overspeed active
23	1 = Ref loss active
24	1 = Emg stop alarm active
25	1 = Power down active
26	1 = not used
27	1 = not used
28	1 = not used
29	1 = not used
30	1 = not used
31	1 = not used

Menu	PAR	Description	UM	Type	FB BIT	Def	Min	Max	Acc
-	4842	Alarm hi state		UINT32	32BIT	0	0	0	ER

This parameter displays the state of alarms 33...64 of the AFE product.

Bit	Description
0	1 = PLC 1 fault active
1	1 = PLC 2 fault active

Bit	Description
2	1 = PLC 3 fault active
3	1 = PLC 4 fault active
4	1 = PLC 5 fault active
5	1 = PLC 6 fault active
6	1 = PLC 7 fault active
7	1 = PLC 8 fault active

Menu	PAR	Description	UM	Type	FB BIT	Def	Min	Max	Acc
-	5800	FL Fwd 1 inv mon		INT32	32BIT	0	0	0	ER
-	5802	FL Fwd 2 inv mon		INT32	32BIT	0	0	0	ER
-	5804	FL Fwd 3 inv mon		INT32	32BIT	0	0	0	ER
-	5806	FL Fwd 4 inv mon		INT32	32BIT	0	0	0	ER
-	5808	FL Fwd 5 inv mon		INT32	32BIT	0	0	0	ER
-	5810	FL Fwd 6 inv mon		INT32	32BIT	0	0	0	ER
-	5812	FL Fwd 7 inv mon		INT32	32BIT	0	0	0	ER
-	5814	FL Fwd 8 inv mon		INT32	32BIT	0	0	0	ER

These parameters are not used on the master drive.

On the slave drive these parameters show the value received from the previous drive. The "Inv" parameters enable the value received to be used with the opposite sign, without changing any of the data sent to subsequent slaves.

These parameters are available in the "src" analog parameter selection lists.

Menu	PAR	Description	UM	Type	FB BIT	Def	Min	Max	Acc
-	6000	Null		UINT32	32BIT	0	0	0	ER

This signal forces the variable to the zero level (always disabled).

Menu	PAR	Description	UM	Type	FB BIT	Def	Min	Max	Acc
-	6002	One		UINT32	32BIT	1	1	1	ER

This signal forces the variable to level one (always active).

8.2 Selection Lists

PAR	Description	Menu	PAR	Description	Menu	PAR	Description	Menu
L ANOUT			L CMP					
6000	Null	(*)	XXXX	(1)		<i>(1) the XXXX parameter changes according to the src parameter used:</i>		
250	Output current	1.1	250	Output current	1.1	3660	Compare input 1 src	
252	Output voltage	1.2	252	Output voltage	1.2	(1)	= 3650 Dig compare input 1	13.3.1
254	Output frequency	1.3	254	Output frequency	1.3	3662	Compare input 2 src	
280	Active current ref	1.6	280	Active current ref	1.6	(1)	= 3652 Dig compare input 2	13.3.2
282	React curr ref mon	1.7	282	React curr ref mon	1.7			
284	Active current	1.8	284	Active current	1.8			
286	Reactive current	1.9	286	Reactive current	1.9			
2388	Active curr noflt	(*)	2388	Active curr noflt	(*)			
270	DC link voltage	1.4	270	DC link voltage	1.4			
1500	Analog input 1 mon	9.1	1500	Analog input 1 mon	9.1			
1550	Analog input 2 mon	9.17	1550	Analog input 2 mon	9.17			
1600	Analog input 1X mon	9.33	1600	Analog input 1X mon	9.33			
1650	Analog input 2X mon	9.44	1650	Analog input 2X mon	9.44			
368	Drive overload accum	1.16	368	Drive overload accum	1.16			
4024	Fieldbus M->S1 mon	14.3.3	3260	Bres overload accum	(*)			
4034	Fieldbus M->S2 mon	14.3.7	4024	Fieldbus M->S1 mon	14.3.3			
4044	Fieldbus M->S3 mon	14.3.11	4034	Fieldbus M->S2 mon	14.3.7			
4054	Fieldbus M->S4 mon	14.3.15	4044	Fieldbus M->S3 mon	14.3.11			
4064	Fieldbus M->S5 mon	14.3.19	4054	Fieldbus M->S4 mon	14.3.15			
4074	Fieldbus M->S6 mon	14.3.23	4064	Fieldbus M->S5 mon	14.3.19			
4084	Fieldbus M->S7 mon	14.3.27	4074	Fieldbus M->S6 mon	14.3.23			
4094	Fieldbus M->S8 mon	14.3.31	4084	Fieldbus M->S7 mon	14.3.27			
4104	Fieldbus M->S9 mon	14.3.35	4094	Fieldbus M->S8 mon	14.3.31			
4114	Fieldbus M->S10 mon	14.3.39	4104	Fieldbus M->S9 mon	14.3.35			
4124	Fieldbus M->S11 mon	14.3.43	4114	Fieldbus M->S10 mon	14.3.39			
4134	Fieldbus M->S12 mon	14.3.47	4124	Fieldbus M->S11 mon	14.3.43			
4144	Fieldbus M->S13 mon	14.3.51	4134	Fieldbus M->S12 mon	14.3.47			
4154	Fieldbus M->S14 mon	14.3.55	4144	Fieldbus M->S13 mon	14.3.51			
4164	Fieldbus M->S15 mon	14.3.59	4154	Fieldbus M->S14 mon	14.3.55			
4174	Fieldbus M->S16 mon	14.3.63	4164	Fieldbus M->S15 mon	14.3.59			
3700	Pad 1	13.4.1	4174	Fieldbus M->S16 mon	14.3.63			
3702	Pad 2	13.4.2	3700	Pad 1	13.4.1			
3704	Pad 3	13.4.3	3702	Pad 2	13.4.2			
3706	Pad 4	13.4.4	3704	Pad 3	13.4.3			
3708	Pad 5	13.4.5	3706	Pad 4	13.4.4			
3710	Pad 6	13.4.6	3708	Pad 5	13.4.5			
3712	Pad 7	13.4.7	3710	Pad 6	13.4.6			
3714	Pad 8	13.4.8	3712	Pad 7	13.4.7			
3716	Pad 9	13.4.9	3714	Pad 8	13.4.8			
3718	Pad 10	13.4.10	3716	Pad 9	13.4.9			
3720	Pad 11	13.4.11	3718	Pad 10	13.4.10			
3722	Pad 12	13.4.12	3720	Pad 11	13.4.11			
3724	Pad 13	13.4.13	3722	Pad 12	13.4.12			
3726	Pad 14	13.4.14	3724	Pad 13	13.4.13			
3728	Pad 15	13.4.15	3726	Pad 14	13.4.14			
3730	Pad 16	13.4.16	3728	Pad 15	13.4.15			
5008	Test gen out	19.1.5	3730	Pad 16	13.4.16			
5750	FL Fwd 1 mon	14.8.13	5750	FL Fwd 1 mon	14.8.13			
5752	FL Fwd 2 mon	14.8.14	5752	FL Fwd 2 mon	14.8.14			
5754	FL Fwd 3 mon	14.8.15	5754	FL Fwd 3 mon	14.8.15			
5756	FL Fwd 4 mon	14.8.16	5756	FL Fwd 4 mon	14.8.16			
5758	FL Fwd 5 mon	14.8.17	5758	FL Fwd 5 mon	14.8.17			
5760	FL Fwd 6 mon	14.8.18	5760	FL Fwd 6 mon	14.8.18			
5762	FL Fwd 7 mon	14.8.19	5762	FL Fwd 7 mon	14.8.19			
5764	FL Fwd 8 mon	14.8.20	5764	FL Fwd 8 mon	14.8.20			
5800	FL Fwd 1 inv mon	(*)	5800	FL Fwd 1 inv mon	(*)			
5802	FL Fwd 2 inv mon	(*)	5802	FL Fwd 2 inv mon	(*)			
5804	FL Fwd 3 inv mon	(*)	5804	FL Fwd 3 inv mon	(*)			
5806	FL Fwd 4 inv mon	(*)	5806	FL Fwd 4 inv mon	(*)			
5808	FL Fwd 5 inv mon	(*)	5808	FL Fwd 5 inv mon	(*)			
5810	FL Fwd 6 inv mon	(*)	5810	FL Fwd 6 inv mon	(*)			
5812	FL Fwd 7 inv mon	(*)	5812	FL Fwd 7 inv mon	(*)			
5814	FL Fwd 8 inv mon	(*)	5814	FL Fwd 8 inv mon	(*)			
						L DIGSEL1		
						6000	Null	-
						66000	Null	(*)
						6002	One	(*)
						1110	Digital input E mon	(*)
						1112	Digital input 1 mon	(*)
						1114	Digital input 2 mon	(*)
						1116	Digital input 3 mon	(*)
						1118	Digital input 4 mon	(*)
						1120	Digital input 5 mon	(*)
						1210	Digital input 1X mon	(*)
						1212	Digital input 2X mon	(*)
						1214	Digital input 3X mon	(*)
						1216	Digital input 4X mon	(*)
						1218	Digital input 5X mon	(*)
						1220	Digital input 6X mon	(*)
						1222	Digital input 7X mon	(*)
						1224	Digital input 8X mon	(*)
						5510	Digital input 9X mon	(*)
						5512	Digital input 10X mon	(*)
						5514	Digital input 11X mon	(*)
						5516	Digital input 12X mon	(*)
						5518	Digital input 13X mon	(*)
						5520	Digital input 14X mon	(*)
						5522	Digital input 15X mon	(*)
						5524	Digital input 16X mon	(*)
						1062	Drive OK	(*)
						1064	Drive ready	(*)
						1066	Enable state mon	1.17
						1068	Enable ready mon	(*)
						1024	Enable cmd mon	6.8
						4708	Alm dig out mon 1	(*)
						4710	Alm dig out mon 2	(*)
						4712	Alm dig out mon 3	(*)
						4714	Alm dig out mon 4	(*)
						1530	Analog inp1<thr	(*)
						1580	Analog inp2<thr	(*)
						362	Drive overload trip	(*)
						366	Drive overload 80%	(*)
						4454	Bit0 decomp mon	14.6.3
						4456	Bit1 decomp mon	14.6.4
						4458	Bit2 decomp mon	14.6.5
						4460	Bit3 decomp mon	14.6.6
						4462	Bit4 decomp mon	14.6.7
						4464	Bit5 decomp mon	14.6.8
						4466	Bit6 decomp mon	14.6.9
						4468	Bit7 decomp mon	14.6.10
						4470	Bit8 decomp mon	14.6.11
						4472	Bit9 decomp mon	14.6.12
						4474	Bit10 decomp mon	14.6.13
						4476	Bit11 decomp mon	14.6.14
						4478	Bit12 decomp mon	14.6.15
						4480	Bit13 decomp mon	14.6.16
						4482	Bit14 decomp mon	14.6.17
						4484	Bit15 decomp mon	14.6.18
						3700	Pad 1	13.4.1
						3702	Pad 2	13.4.2

PAR	Descrizione	Menu	PAR	Description	Menu	PAR	Description	Menu
5850	FL Rev 1 mon	14.8.21	3702	Pad 2	13.4.2	3714	Pad 8	13.4.8
5852	FL Rev 2 mon	14.8.22	3704	Pad 3	13.4.3	3716	Pad 9	13.4.9
5854	FL Rev 3 mon	14.8.23	3706	Pad 4	13.4.4	3718	Pad 10	13.4.10
5856	FL Rev 4 mon	14.8.24	3708	Pad 5	13.4.5	3720	Pad 11	13.4.11
			3710	Pad 6	13.4.6	3722	Pad 12	13.4.12
			3712	Pad 7	13.4.7	3724	Pad 13	13.4.13
			3714	Pad 8	13.4.8	3726	Pad 14	13.4.14
			3716	Pad 9	13.4.9	3728	Pad 15	13.4.15
			3718	Pad 10	13.4.10	3730	Pad 16	13.4.16
			3720	Pad 11	13.4.11	6000	Null	(*)
			3722	Pad 12	13.4.12	5008	Test gen out	19.1.5
			3724	Pad 13	13.4.13	5750	FL Fwd 1 mon	14.8.13
			3726	Pad 14	13.4.14	5752	FL Fwd 2 mon	14.8.14
			3728	Pad 15	13.4.15	5754	FL Fwd 3 mon	14.8.15
			3730	Pad 16	13.4.16	5756	FL Fwd 4 mon	14.8.16
			5008	Test gen out	19.1.5	5758	FL Fwd 5 mon	14.8.17
			5750	FL Fwd 1 mon	14.8.13	5760	FL Fwd 6 mon	14.8.18
			5752	FL Fwd 2 mon	14.8.14	5762	FL Fwd 7 mon	14.8.19
			5754	FL Fwd 3 mon	14.8.15	5764	FL Fwd 8 mon	14.8.20
			5756	FL Fwd 4 mon	14.8.16	5800	FL Fwd 1 inv mon	(*)
			5758	FL Fwd 5 mon	14.8.17	5802	FL Fwd 2 inv mon	(*)
			5760	FL Fwd 6 mon	14.8.18	5804	FL Fwd 3 inv mon	(*)
			5762	FL Fwd 7 mon	14.8.19	5806	FL Fwd 4 inv mon	(*)
			5764	FL Fwd 8 mon	14.8.20	5808	FL Fwd 5 inv mon	(*)
			5800	FL Fwd 1 inv mon	(*)	5810	FL Fwd 6 inv mon	(*)
			5802	FL Fwd 2 inv mon	(*)	5812	FL Fwd 7 inv mon	(*)
			5804	FL Fwd 3 inv mon	(*)	5814	FL Fwd 8 inv mon	(*)
			5806	FL Fwd 4 inv mon	(*)			
			5808	FL Fwd 5 inv mon	(*)			
			5810	FL Fwd 6 inv mon	(*)			
			5812	FL Fwd 7 inv mon	(*)			
			5814	FL Fwd 8 inv mon	(*)			

L MLTREF	
1500	Analog input 1 mon 9.1
1550	Analog input 2 mon 9.17
1600	Analog input 1X mon 9.33
1650	Analog input 2X mon 9.44
4024	Fieldbus M->S1 mon 14.3.3
4034	Fieldbus M->S2 mon 14.3.7
4044	Fieldbus M->S3 mon 14.3.11
4054	Fieldbus M->S4 mon 14.3.15
4064	Fieldbus M->S5 mon 14.3.19
4074	Fieldbus M->S6 mon 14.3.23
4084	Fieldbus M->S7 mon 14.3.27
4094	Fieldbus M->S8 mon 14.3.31
4104	Fieldbus M->S9 mon 14.3.35
4114	Fieldbus M->S10 mon 14.3.39
4124	Fieldbus M->S11 mon 14.3.43
4134	Fieldbus M->S12 mon 14.3.47
4144	Fieldbus M->S13 mon 14.3.51
4154	Fieldbus M->S14 mon 14.3.55
4164	Fieldbus M->S15 mon 14.3.59
4174	Fieldbus M->S16 mon 14.3.63
3700	Pad 1 13.4.1
3702	Pad 2 13.4.2
3704	Pad 3 13.4.3
3706	Pad 4 13.4.4
3708	Pad 5 13.4.5
3710	Pad 6 13.4.6
3712	Pad 7 13.4.7
3714	Pad 8 13.4.8
3716	Pad 9 13.4.9
3718	Pad 10 13.4.10
3720	Pad 11 13.4.11
3722	Pad 12 13.4.12
3724	Pad 13 13.4.13
3726	Pad 14 13.4.14
3728	Pad 15 13.4.15
3730	Pad 16 13.4.16
5008	Test gen out 19.1.5

L REF	
1500	Analog input 1 mon 9.1
1550	Analog input 2 mon 9.17
1600	Analog input 1X mon 9.33
1650	Analog input 2X mon 9.44
4024	Fieldbus M->S1 mon 14.3.3
4034	Fieldbus M->S2 mon 14.3.7
4044	Fieldbus M->S3 mon 14.3.11
4054	Fieldbus M->S4 mon 14.3.15
4064	Fieldbus M->S5 mon 14.3.19
4074	Fieldbus M->S6 mon 14.3.23
4084	Fieldbus M->S7 mon 14.3.27
4094	Fieldbus M->S8 mon 14.3.31
4104	Fieldbus M->S9 mon 14.3.35
4114	Fieldbus M->S10 mon 14.3.39
4124	Fieldbus M->S11 mon 14.3.43
4134	Fieldbus M->S12 mon 14.3.47
4144	Fieldbus M->S13 mon 14.3.51
4154	Fieldbus M->S14 mon 14.3.55
4164	Fieldbus M->S15 mon 14.3.59
4174	Fieldbus M->S16 mon 14.3.63
3700	Pad 1 13.4.1

L SCOPE	
6000	Null -

L VREF	
XXXX (3)	
11500	Analog input 1 mon 9.1
1550	Analog input 2 mon 9.17
1600	Analog input 1X mon 9.33
1650	Analog input 2X mon 9.44
4024	Fieldbus M->S1 mon 14.3.3
4034	Fieldbus M->S2 mon 14.3.7
4044	Fieldbus M->S3 mon 14.3.11
4054	Fieldbus M->S4 mon 14.3.15
4064	Fieldbus M->S5 mon 14.3.19
4074	Fieldbus M->S6 mon 14.3.23
4084	Fieldbus M->S7 mon 14.3.27
4094	Fieldbus M->S8 mon 14.3.31
4104	Fieldbus M->S9 mon 14.3.35
4114	Fieldbus M->S10 mon 14.3.39
4124	Fieldbus M->S11 mon 14.3.43
4134	Fieldbus M->S12 mon 14.3.47
4144	Fieldbus M->S13 mon 14.3.51
4154	Fieldbus M->S14 mon 14.3.55
4164	Fieldbus M->S15 mon 14.3.59
4174	Fieldbus M->S16 mon 14.3.63
3700	Pad 1 13.4.1
3702	Pad 2 13.4.2
3704	Pad 3 13.4.3
3706	Pad 4 13.4.4
3708	Pad 5 13.4.5
3710	Pad 6 13.4.6
3712	Pad 7 13.4.7

L WDECOMP	
XXXX (4)	
6000	Null (*)
6002	One (*)
4432	Word comp mon 14.5.17
4024	Fieldbus M->S1 mon 14.3.3
4034	Fieldbus M->S2 mon 14.3.7
4044	Fieldbus M->S3 mon 14.3.11
4054	Fieldbus M->S4 mon 14.3.15
4064	Fieldbus M->S5 mon 14.3.19
4074	Fieldbus M->S6 mon 14.3.23
4084	Fieldbus M->S7 mon 14.3.27
4094	Fieldbus M->S8 mon 14.3.31
4104	Fieldbus M->S9 mon 14.3.35
4114	Fieldbus M->S10 mon 14.3.39
4124	Fieldbus M->S11 mon 14.3.43
4134	Fieldbus M->S12 mon 14.3.47
4144	Fieldbus M->S13 mon 14.3.51
4154	Fieldbus M->S14 mon 14.3.55
4164	Fieldbus M->S15 mon 14.3.59
4174	Fieldbus M->S16 mon 14.3.63
3700	Pad 1 13.4.1
3702	Pad 2 13.4.2
3704	Pad 3 13.4.3
3706	Pad 4 13.4.4
3708	Pad 5 13.4.5
3710	Pad 6 13.4.6

(3) the XXXX parameter changes according to the src parameter used:

(3) = DC voltage ref src
Dig DC voltage ref 5.1

(3) = 610 Vdc reference src
606 Ramp DC link out (*)

PAR	Description	Menu	PAR	Description	Menu	PAR	Description	Menu
3712	Pad 7	13.4.7						
3714	Pad 8	13.4.8						
3716	Pad 9	13.4.9						
3718	Pad 10	13.4.10						
3720	Pad 11	13.4.11						
3722	Pad 12	13.4.12						
3724	Pad 13	13.4.13						
3726	Pad 14	13.4.14						
3728	Pad 15	13.4.15						
3730	Pad 16	13.4.16						
5750	FL Fwd 1 mon	14.8.13						
5752	FL Fwd 2 mon	14.8.14						
5754	FL Fwd 3 mon	14.8.15						
5756	FL Fwd 4 mon	14.8.16						
5758	FL Fwd 5 mon	14.8.17						
5760	FL Fwd 6 mon	14.8.18						
5762	FL Fwd 7 mon	14.8.19						
5764	FL Fwd 8 mon	14.8.20						
5800	FL Fwd 1 inv mon	(*)						
5802	FL Fwd 2 inv mon	(*)						
5804	FL Fwd 3 inv mon	(*)						
5806	FL Fwd 4 inv mon	(*)						
5808	FL Fwd 5 inv mon	(*)						
5810	FL Fwd 6 inv mon	(*)						
5812	FL Fwd 7 inv mon	(*)						
5814	FL Fwd 8 inv mon	(*)						

(4) the XXXX parameter changes according to the src parameter used:

4452 Word decomp src
 (4) = 4450 Dig word decomp 14.6.1

(*) Parameter not shown on the keypad.
 For information see the "PARAMETERS INCLUDED IN SELECTION LISTS BUT NOT SHOWN ON THE KEYPAD" section.

9 - Troubleshooting

9.1 Alarms

Note !

To reset alarms, see Quick start guide, [paragraph 6.6.1](#).

In the following table, the Code is visible only from serial line.

Code	Error message shown on the display	Sub-code	Description
0	No alarm	Condition: No alarm present	
1	Overvoltage	Condition: DC link overvoltage alarm due to energy recovered from the motor. The voltage supplied to the AFE power section is too high with respect to the maximum limit. Solution: - Increase the bandwidth of the voltage regulator (if the problem occurs under dynamic conditions) - Use a larger AFE.	
2	Undervoltage	Condition: DC link undervoltage alarm. The voltage arriving at the AFE power section is too low compared to the minimum threshold relating to the 560 Mains voltage parameter setting due to: - the mains voltage being too low or overextended voltage drops. - poor cable connections (e.g. loose contactor terminals, inductance, filter, etc.). Solution: Check the connections and measure the mains voltage.	
3	Ground fault	Condition: Ground short circuit alarm Solution: - Check the AFE and pre-load circuit wiring.	
4	Overcurrent	Condition: Instantaneous overcurrent protection intervention alarm. This may be due to the incorrect setting of current regulator parameters or a short circuit between phases or ground fault on the AFE output. Solution: - Check the current regulator parameters - Check the wiring to the mains and make sure the mains phases match those of the synchronisation card.	
5	Desaturation	Condition: Instantaneous overcurrent in the IGBT bridge alarm. Solution: Switch the AFE off and then switch it on again. If the alarm persists, contact the technical service centre.	
6	MultiUndervolt	Condition: The number of attempted automatic restarts after the Undervoltage alarm has exceeded the set PAR 4650 Underv res attempt value in the PAR 4652 Underv res delay time . Solution: Too many Undervoltage alarms. Adopt the proposed solutions for the Undervoltage alarm.	
7	MultiOvercurr	Condition: 2 attempted automatic restarts after the Overcurrent alarm within 30 seconds. If more than 30 seconds pass after the Overcurrent alarm was generated, the attempt counter is reset. Solution: Too many Overcurrent alarms. Adopt the proposed solutions for the Overcurrent alarm	
8	MultiDesat	Condition: 2 attempted at automatic restarts after the Desaturation alarm within 30 seconds. If more than 30 seconds pass after the Desaturation alarm was generated, the attempt counter is reset. Solution: Too many Desaturation alarms. Adopt the proposed solutions for the Desaturation alarm.	
9	Undervolt AC	Condition: The measured mains voltage is too low	

Code	Error message shown on the display	Sub-code	Description
			Solution: Check the cables connected to the mains voltage measurement card. - Check for the presence of the mains voltage
10	Overvoltage AC		The measured mains voltage is too high
			Solution: Check the cables connected to the mains voltage measurement card. - Check the readings of parameters PAR 256 Phase U voltage , PAR 258 Phase V voltage , PAR 260 Phase W voltage
11	Heatsink OT		Condition: Heatsink temperature too high alarm
			Solution: - Verify the correct operation of the cooling fan. - Check that the heatsinks are not clogged - Check that the openings for the cabinet cooling air are not blocked.
12	Heatsinks OTUT		Condition: IGBT modules temperature too high or too low alarm.
			Solution: - Verify the correct operation of the cooling fan. - Check that the heatsinks are not clogged - Check that the openings for the cabinet cooling air are not blocked.
13	Intakeair OT		Condition: Intake drive air temperature too high alarm
			Solution: - Check correct fan operation - Check that panel cooling air openings are unobstructed. - Check temperature in electrical panel.
14	Drive overload		Condition: Drive overload alarm. The overload threshold of the accumulator of the I ² t AFE thermal image has been exceeded.
			Solution: Check that the size of the AFE is suitable for the application.
15	Bres overload		Condition: Braking resistor overload alarm. The current absorbed by the resistor is greater than the rated current. The overload threshold of the accumulator of the I ² t braking resistor thermal image has been exceeded. Not available for standard AFE200.
			Solution: Increase the Watt value of the braking resistor
16	Opt Bus fault		Condition: Error in the configuration stage or communication error.
		XXX0H-X	If the first digit to the left of "H" in the alarm sub-code is 0, the error regards a communication problem.
		XXXXH-X	If the first digit to the left of "H" in the alarm sub-code is other than 0, the error regards a configuration problem.
			Solution: For configuration errors, check the configuration of the Bus communication, Bus type, Baudrate, address, parameter settings. For communication errors verify wiring, resistance of terminations, interference immunity, timeout settings. For further details, please refer to the user guide for the specific bus.
17	Opt 1 IO fault		Condition: Error in the communication between Regulation and I/O expansion card in slot 1.
			Solution: Check that it has been inserted correctly, see chapter 11.5
18	Opt 2 IO fault		Condition: Error in the communication between Regulation and I/O expansion card in slot 2.
			Solution: Check that it has been inserted correctly, see chapter 11.5
19	Opt Enc fault		Condition: Error in communications between the regulation board and voltage synchronisation card in slot 2
			Solution: Check that they are inserted correctly

Code	Error message shown on the display	Sub-code	Description
20	External fault		Condition: External alarm present. A digital input has been programmed as an external alarm, but the +24V voltage is not available on the terminal.
			Solution: Check that the terminal screws are tight
21	Emg stop alarm		Condition: Emergency stop alarm. The Stop key on the keypad was pressed with the PAR 1008 Stop key mode parameter set to EmgStop&Alarm. Active in remote control mode (PAR 1012=1) both by using "Terminals" command or "Digital" commands and, in local control mode (PAR 1012=0) by using "Terminals" command.
			Solution: Eliminate the reason for which the Stop key on the keypad was pressed and reset the AFE.
22	Power down		Condition: The AFE was enabled with no supply voltage at the power section.
			Solution: Check the AFE power supply
23	Prc fbk loss		Condition: No confirmation of pre-load contactor alarm
			Solution: Check the condition of the pre-load contactor
24 ... 26	Not Used1...3		
27	ExtI0 fault		Condition: Communication fault with the external module.
			Solution: See paragraph "9.1.1 "ExtI0 fault" Alarm" on page 163
28	FastLink fault		Condition: FastLink communication fault.
			Solution: See paragraph "9.1.2 "Fastlink fault" Alarm" on page 164
29 ... 32	Not Used6...9		
33 ... 40	Plc1 fault ... Plc8 fault		Condition: Enabled application developed in the IEC 61131-3 environment has found the conditions for generating this specific alarm to be true. The meaning of the alarm depends on the type of application. For more information, refer to the documentation concerning the specific application.
		XXXXH-X	The XXXXH-X code indicates the reason for the error: make a note of this to discuss it with the service centre.
			Solution: Refer to the documentation concerning the enabled application.

9.1.1 “ExtIO fault” Alarm

The drive may generate an “ExtIO fault” alarm for a series of reasons. At drive startup there may be problems with configuration, associated with the EXP-FL-XCAN-ADV card or parameter settings. During the Config phase the alarm might depend on an SDO communication error. During the Control phase the HeartBeat or NodeGuarding protocol might fail due to an interruption in the communication with the slave. An Emergency message sent by the slave could generate the “ExtIO fault” alarm.

Each reason for the alarm can be identified by to the associated subcode. The table below shows information about the subcodes and how to associate these with the cause of the alarm, to enable troubleshooting and proper use of the system.

Subcode		Description	Remarks
0	0	BusLoss	Loss of communication in the Operational state
1..51	1h..35h	SDO error	Error sending the SDO. See the SDO Configuration Table on appendix to identify the object with the problem
200	0xC8	CAN error	Internal hardware fault; if the problem cannot be solved, replace the regulation card
202	0xCA	Config error	The number or I/Os in the slave module has changed. Check parameter 5482 External IO info . Save the parameters to store the current configuraiton.
203	0xCB	Lost Messages	TPDOs coming from the slave too frequently. Check that the slave meets CANopen specifications for TPDO sending times
204	0xCC	Opt IO installed	An optional internal I/O expansion card has been installed. The EXP-XCAN-ADV card functions are not available.
255..65535	0xFF..0xFFFF	Slave Emergency	Emergency message sent by the slave.

If the alarm is due to an Emergency message sent by the slave, the subcode contains the error code (Error code low and Error code Hi) of the message, while 4 of the 5 additional bytes in the message are shown by parameter 5486 **External IO Failcode**.

Emergency message content:

Byte0	Byte1	Byte2	Byte3	Byte4	Byte5	Byte6	Byte7
Error code Low	Error code Hi	Error register	Info 0	Info 1	Info 2	Info3	Info4
Subcode	PAR 5486 External IO Failcode						

See the slave manual for information about the meaning of the Emergency message.

9.1.2 “Fastlink fault” Alarm

Reasons why the FastLink alarm is generated:

Bit					Name	Description
	D3	D2	D1	D0		
0				0x1	Cks	Cause: The drive has detected a checksum error Solution: Take all the necessary precautions to increase the resistance of the drive to disturbance
1				0x2	Not used	Cause: Solution:
2				0x4	Not used	Cause: Solution:
3				0x8	Not used	Cause: Solution:
4			0x1		Not used	Cause: Solution:
5			0x2		RX Timeout	Cause: The slave drive has not received a new data frame for 2 consecutive cycles. Solution: Take all the necessary precautions to increase the resistance of the drive to disturbance
6			0x4		Pwm sync slave	Cause: On the slave drives there is a problem with the function that enables the generation of Pwm signals to be synchronised with the Pwm signals of the master and with the function that enables the execution of control tasks to be synchronised with execution of control tasks by the master. An error exceeding the maximum error allowed has been detected for 4 consecutive cycles. Solution: Take all the necessary precautions to increase the resistance of the drive to disturbance
7			0x8		Cable open	Cause: No optical fibre. Solution: Check connection with optical fibre.
8		0x1			Setup error	Cause: An error occurred during setup; the information received from the FastLink is not reliable. Solution: Check setting of FastLink parameters.
9		0x2			Compatibility error	Cause: The firmware on the optional FastLink card is incompatible with that on the regulation card. Solution: Contact Gefran in order to update the firmware on the optional fastlink card.
10		0x4			Slave answer NOK	Cause: situation in which an interrogated Slave does not reply Solution: check FastLink connection

9.2 Messages

Note !

For more information see [chapter 6.7](#).

Error message shown on the display	Sub-code	Description
Fast IO error	Condition: may occur at AFE start-up, during card recognition	
	0000H-0	Fast IO error (Bus synchronisation)
	Solution: contact the Gefran technical support centre.	
Key expiring	Condition: this may occur at AFE power-on if the incorrect enabling key was inserted for a given firmware function. At this stage the firmware function can still be used freely, but this time limit is about to expire.	
	xxxxH-x	Number of hours for which the function can still be used freely.
	Solution: Ask Gefran for the correct key to enable the desired firmware function.	
Load default	Condition: may occur during loading of the parameter database saved in flash normally appears in the following conditions: at initial power-on when a new firmware version is downloaded, when the regulation is installed on a new size, when the region is changed. If this message is displayed when the AFE is already operating, this means that a problem has occurred in the parameter database saved in Flash. If this message is displayed, the AFE automatically performs the Load default command.	
	0001H-1	The database saved is not valid
	0002H-2	The database saved is not compatible
	0003H-3	The database saved refers to a different size from the current size
	0004H-4	The database saved refers to a different region from the current region
	Solution: Set the parameters to the value required and perform Save parameter	
Load def plc	Condition: may occur during loading of the parameter database saved in the Flash of the Mdplc application Normally appears at initial power-on after downloading a new application. If this message is displayed when the AFE is already operating, this means that a problem has occurred in the parameter database saved in Flash. If this message appears the AFE restores the default database, i.e. the one that was downloaded.	
	0001H-1	The database saved is not valid
	Solution: Set the parameters to the value required and perform Save parameter	
Load par failed	Condition: during transfer of the parameters from the memory of the keypad to the AFE	
	0H-0	Communication error
	0025H-37	The data saved on the keypad are not valid. No parameter is transferred from the keypad to the AFE
	0026H-38	Incompatible AFE series. No parameter is transferred from the keypad to the AFE
	0027H-39	Incompatible software version. All the parameters present in the memory of the keypad have been transferred to the AFE. The set of parameters transferred refers to a AFE with a different firmware version; therefore, certain parameters may not be updated.
	0028H-40	Incompatible AFE size. All the parameters present in the memory of the keypad (excluding those that depend on the size of the AFE), have been transferred to the AFE. The parameters that depend on size maintain their original value.
	0029H-41	Error during saving of parameters on the AFE. All the parameters present in the memory of the keypad have been transferred to the AFE. The transfer of one or more parameters has caused an "out of range" error, or one or more parameters does not exist. At the end of transfer, one or more parameters may not have been updated.

Error message shown on the display	Sub-code	Description	
	002AH-42	PLC application release and version not compatible. All parameters in the keypad memory have been transferred to the AFE. The transferred set of parameters relates to a AFE with a PLC application in which the version and release of the application are different. As a result some of the PLC application parameters may not be updated.	
	002BH-43	PLC application not compatible. All the parameters in the keypad memory except those relating to the PLC application have been transferred to the AFE. The transferred set of parameters relates to a AFE with a different PLC application. As a result none of the PLC application parameters are updated.	
	Solution: Recover a set of parameters from a compatible AFE (model and size)		
Options config error	Condition: may occur at AFE start-up, during recognition of the optional cards installed		
	0001H-1	Non-permissible optional card in slot 1	
	0002H-2	Non-permissible optional card in slot 2	
	0004H-4	Non-permissible optional card in slot 3	
	0010H-16	Conflict slot 1 with slot 2	
	0020H-32	Conflict slot 1 with slot 3	
	0040H-64	Conflict slot 2 with slot 3	
	Solution: Remove the optional cards from the incorrect slots and insert them in the correct slots		
Option detect slot 1 Option detect slot 2 Option detect slot 3	Condition: at power-on, the AFE recognizes the presence of an optional card in one of the three expansion slots. One of the three messages is shown on the display		
	0H-0	None	
	0001H-1	I_0_1	
	0004H-4	Can_Dnet	
	00FFH-255	Unknown	
	0101H-257	I_0_2	
	0104H-260	Profibus	
	0020H-32	Fast IO (Sync-ON card)	
	0201H-513	I_0_3	
	0204H-516	Gdnet	
	0301H-769	I_0_4	
	Solution:		
	Plc cfg error	Condition: may occur during loading of the Mdplc application The Mdplc application present on the AFE is not run.	
		0004H-4	The application downloaded has a different Crc on DataBlock and Function table
		0065H-101	The application downloaded has an invalid identifier (Info)
0066H-102		The application downloaded has an incorrect task number (Info)	
0067H-103		The application downloaded has an incorrect software configuration	
0068H-104		The application downloaded has a different Crc on DataBlock and Function table	
0069H-105		A Trap error or System error has occurred. The AFE automatically performs a Power-up operation. The application is not run. See in Alarm List for further information regarding the error occurred	
006AH-106		The application downloaded has an incorrect identifier (Task)	
006BH-107		The application downloaded has an incorrect task number (Task)	
006CH-108		The application downloaded has an incorrect Crc (Tables + Code)	
Solution: Remove the Mdplc application or download a correct Mdplc application			

Error message shown on the display	Sub-code	Description
Power config	Condition:	may occur during recognition of power cards. The AFE cannot be enabled when this message is shown.
	0020H-32	The power card is configured for a AFE that is incompatible with the regulation card
	0021H-33	The configuration of the power card is not compatible with the regulation card
	0017H-23	The configuration required is not available on the power card
	Solution:	Download the correct configuration on the power card
Save par failed	Condition:	during transfer of the parameters from the AFE to the memory of the keypad
	0H-0	Communication error
	0025H-37	The data saved on the keypad are not valid
	0026H-38	Incompatible AFE series
	0027H-39	Incompatible software version
	0028H-40	Incompatible AFE size
	0029H-41	Error during saving of parameters on the AFE
	Solution:	

10 - Specification

10.1 Environmental Conditions

Installation location _____	Pollution degree 2 or lower (free from direct sunlight, vibration, dust, corrosive or inflammable gases, fog, vapour oil and dripped water, avoid saline environment)
Installation altitude _____	Max 2000m (6562 feet) above sea level;.
Mechanical conditions for installation _____	Vibrational stress: EN 60721-3-3 Class 3M1
Operating temperature _____	-10... +40°C (32°...104°F)
Operating temperature (1) _____	+40 ... +50°C with derating, (+104 ... +122°F with derating)
Air humidity (operating) _____	5 % to 85 % and 1 g/m ³ to 25 g/m ³ without moisture condensation or icing (class 3K3 as per EN50178)
Air pressure (operating) [kPa] _____	86 to 106 (class 3K3 as per EN50178)

- (1) In menu 4 - DRIVE CONFIG set the **Ambient temperature** parameter, PAR 564, to 1 (50°C).
10 % derating of output current.

10.2 Standards

Climatic conditions _____	EN 60721-3-3
Electrical safety _____	EN 50178, EN 61800-5-1, UL508C, UL840 degree of pollution 2
Vibration _____	EN 60068-2-6, test Fc.
EMC compatibility _____	EN61800-3
Protection degree _____	Sizes 3.. 6: IP20; Size 7: IP00 (with protection against accidental contact)
EC Directives _____	LVD 2014/35/EU, EMC 2014/30/EU, RoHs 2011/65/EU

Approvals _____



- (*) Sizes AFE200-...-6 with 690 V power supply are not UL-marked..

10.3 Accuracy

10.3.1 Current control

Loop sampling time _____	62,5μs
Response time _____	800 - 1000μs
PWM frequency _____	2, 3, 4, 6, 8 kHz (size dependent)

10.3.2 Voltage control

Loop sampling time _____	62,5μs
Response time _____	10 - 15ms

10.3.3 Current rating

Heavy duty (HD) _____	150% 60 sec, 180% 0.5 sec.
Light duty (LD) _____	110% 60 sec.
Switching frequency mode (LD) _____	2, 3 or 4 kHz, size dependent
Switching frequency mode (HD) _____	2, 3, 4, 6, 8 kHz

10.4 Overload

Heavy duty (HD)

150% 60 sec every 300 sec, 180% 0,5 sec.

Light duty (LD)

110% 60 sec every 300 sec.

10.5 DC circuit

DC-link voltage rating _____ 650...780 V_{DC} (AFE-...-4),

820...1120 V_{DC} (AFE-...-6)

DC overvoltage threshold _____ 820 V_{DC} (AFE-...-4), 1192 V_{DC} (AFE-...-6);

DC undervoltage threshold _____ 380 V_{DC} (@ 400 V_{AC}), 676 V_{DC} (@ 690 V_{AC});

563 V_{DC} (@ 575 V_{AC})

Sizes AFE200-	DC-link capacity (AFE200-...-4)	DC-link capacity (AFE200-...-6)
	Internal (μ F)	Internal (μ F)
3220	1500	-
4450	3400	-
5900	6800	-
61320	13600	-
71600	16800	11200
72000	16800	11200
72500	25200	11200
73150	25200	11200
73550	25200	11200
400kW	2 x 16800	2 x 11200
500kW	2 x 25200	2 x 11200
630kW	2 x 25200	2 x 11200
710kW	2 x 25200	2 x 11200
900kW	3 x 25200	3 x 11200
1MW	3 x 25200	3 x 11200
1.35MW	-	4 x 11200
1.65MW	-	5 x 11200

10.6 Electrical data

Input voltage (AFE200-...-4)	380 - 15% ... 500 + 5% V _{AC}
Input voltage (AFE200-...-6)	500 - 10% ... 690 + 10% V _{AC}
Input frequency	50/60 Hz ± 2%
Maximum line voltage unbalance	3 %
THD Input current	≤ 3% (considering AC Mains THD Voltage < 2%)
Cosphi	≥ 0.99
Connection to TT and TN Networks	AFE200-...-4 and AFE200-...-6: = Suitable
Connection to IT Networks:	AFE200-...-4 = Suitable with special EMI filter (on request) AFE200-4450-4 and AFE200-5900-4 = Special version -IT on request + Special EMI filter (on request) AFE200-...-6 = Suitable (with standard EMI filter)

Sizes AFE200-...-4	AC input current		DC output current		fsw Switching frequency		Derating factor			
	Heavy duty	Light duty	Heavy duty	Light duty	Default	Higher	Kv	Kr	Kf (@ 8 kHz)	KALT
	@ 400 V _{AC} (A)	@ 400 V _{AC} (A)	@ 650 V _{DC} (A)	@ 650 V _{DC} (A)	(kHz)	(kHz)	(1)	(2)	(3)	(4)
3220	40	60	43	64	8	-	0.9	0.9	-	1.2
4450	80	100	85	107	8	-	0.9	0.9	-	1.2
5900	160	200	171	213	4	6.8	0.9	0.9	0.7	1.2
61320	230	280	245	298	4	6.8	0.9	0.9	0.7	1.2
71600	280	340	298	363	4	-	0.9	0.9	-	1.2
72000	340	400	363	426	2	4	0.9	0.9	-	1.2
72500	400	500	426	532	2	4	0.9	0.9	-	1.2
73150	500	560	532	597	2	-	0.9	0.9	-	1.2
73550	560	600	597	640	2	-	0.9	0.9	-	1.2
400kW	600	760	640	811	2	-	0.9	0.9	-	1.2
500kW	760	950	811	1012	2	-	0.9	0.9	-	1.2
630kW	950	1060	1012	1129	2	-	0.9	0.9	-	1.2
710kW	1060	1150	1129	1226	2	-	0.9	0.9	-	1.2
900kW	1400	1500	1492	1598	2	-	0.9	0.9	-	1.2
1MW	1500	1730	1598	1846	2	-	0.9	0.9	-	1.2

(1) Kv : Derating factor for mains voltage at 460V_{AC}

(2) Kr : Derating factor for 50°C ambient temperature (1 % each °C above 40°C)

(3) Kf : Derating factor for higher switching frequency

(4) KALT : Derating factor for installation at altitudes above 1000 meters a.s.l.. Value to be applied at each 100 m increase above 1000 m (up to a maximum of 2000 m).

i.e.: Altitude 2000 m, Kalt = 1,2 *10 = 12% di derating; In derated = 100 - ((12*100)/100) = 88 % In

Sizes AFE200-...-6	AC input current		DC output current		fsw Switching frequency		Derating factor			
	Heavy duty	Light duty	Heavy duty	Light duty	Default	Higher	Kv	Kr HEAVY DUTY	Kr Light duty	KALT
	(A)	(A)	(A)	(A)	(kHz)	(kHz)	(6)	(7)	(7)	(8)
71600	150	190	165	210	4	-	1	0.9	0.8	1.2
72000	190	240	210	265	2	-	1	0.9	0.8	1.2
72500	240	300	265	330	2	-	1	0.9	0.8	1.2
73150	300	340	330	375	2	-	1	0.9	0.8	1.2
73550	340 (5)	380	375	420	2	-	1	0.85	0.8	1.2
400kW	360	455	396	500	2	-	1	0.9	0.8	1.2
500kW	455	570	500	627	2	-	1	0.9	0.8	1.2

Sizes AFE200...-6	AC input current		DC output current		fsw Switching frequency		Derating factor			
	Heavy duty	Light duty	Heavy duty	Light duty	Default	Higher	Kv	Kr HEAVY DUTY	Kr Light duty	KALT
	(A)	(A)	(A)	(A)	(kHz)	(kHz)	(6)	(7)	(7)	(8)
630kW	570	645	627	711	2	-	1	0.9	0.8	1.2
710kW	645 (5)	720	711	792	2	-	1	0.85	0.8	1.2
900kW	850	920	935	1012	2	-	1	0.9	0.8	1.2
1MW	920 (5)	1050	1012	1155	2	-	1	0.85	0.8	1.2
1,35MW	1200 (5)	1350	1320	1485	2	-	1	0.85	0.8	1.2
1,65MW	1470 (5)	1645	1615	1810	2	-	1	0.85	0.8	1.2

(5) Current values at ambient temperature of 35°C.

(6) Kv : Derating factor for DC power supply (690 V)

(7) Kr : Derating factor for ambient temperature of 50°C (1% every °C over 40°C with HD and 2% every °C over 40°C with LD)

For sizes 73550, 710 kW and 1 MW: Derating factor for ambient temperatures of > 40°C up to 50°C (1% every °C over 35°C with HD and 2% every °C over 40°C with LD)

(8) KALT : Derating factor for installation at altitudes above 1000 meters a.s.l.. Value to be applied at each 100 m increase above 1000 m (up to a maximum of 2000 m).

I.e.: Altitude 2000 m, KALT = $1,2 \cdot 10 = 12\%$ di derating; In derated = $100 - ((12 \cdot 100)/100) = 88\%$ In

Sizes AFE200-	AC power					
	Output AFE...-4 (@ 400VAc)		Output AFE...-4 (@ 460VAc)		Output AFE...-6 (@ 690VAc)	
	Heavy duty (KW)	Light duty (KW)	Heavy duty (KW)	Light duty (KW)	Heavy duty (KW)	Light duty (KW)
3220	28	42	29	43	-	-
4450	55	69	57	72	-	-
5900	110	139	115	143	-	-
61320	159	194	165	201	-	-
71600	194	236	201	244	179	227
72000	236	277	244	287	227	287
72500	277	346	287	358	287	358
73150	346	388	358	402	358	406
73550	388	416	402	430	406	454
400kW	416	527	430	545	430	544
500kW	527	658	545	681	544	681
630kW	658	734	681	760	681	771
710kW	734	797	760	825	771	860
900kW	970	1039	1004	1075	1015	1100
1MW	1039	1200	1075	1242	1100	1255
1,35MW	-	-	-	-	1434	1613
1,65MW	-	-	-	-	1757	1966

10.7 Voltage level of AFE200 for safe operations

The minimum time between the moment in which an AFE200 is disabled from the mains and that in which an operator can operate on internal parts of the product, without the danger of electric shock, **is 5 minutes**.



Attention

.....
The value consider the time to turn-off for an AFE200 without any options (time indicated for disabled AFE200 condition).
.....

10.8 Cooling

All the AFE200 have internal fans.

Sizes AFE200-		Dissipated power	Airflow of fan	
		W	Heatsink (m ³ /h)	Internal (m ³ /h)
3220		400	80 x 2	32
4450		770	2 x 250	2 x 50
5900		1420	2 x 355	2 x 170
61320		2000	3 x 310	2 x 170
71600		2700	1500	-
72000		3200	1500	-
72500		3600	1500	-
73150		3900	2000	-
73550		4200	2000	-
400kW	72000-KXX-.-MS 04	3200	1500	-
	72000-XXX-.-SL	3200	1500	-
500kW	72500-KXX-.-MS 05	3600	1500	-
	72500-XXX-.-SL	3600	1500	-
630kW	73150-KXX-.-MS 06	3900	2000	-
	73150-XXX-.-SL	3900	2000	-
710kW	73550-KXX-.-MS 07	4200	2000	-
	73550-XXX-.-SL	4200	2000	-
900kW	73150-KXX-.-MS 09	3900	2000	-
	73150-XXX-.-SL	3900	2000	-
	73150-XXX-.-SL	3900	2000	-
1MW	73550-KXX-.-MS 10	4200	2000	-
	73550-XXX-.-SL	4200	2000	-
	73550-XXX-.-SL	4200	2000	-
1.35MW	73550-KXX-6-MS 14	4200	2000	-
	73550-XXX-6-SL2	4200	2000	-
	73550-XXX-6-SL	4200	2000	-
	73550-XXX-6-SL	4200	2000	-
1.65MW	73550-KXX-6-MS 17	4200	2000	-
	73550-XXX-6-SL2	4200	2000	-
	73550-XXX-6-SL2	4200	2000	-
	73550-XXX-6-SL	4200	2000	-

10.9 Weight and dimensions

Sizes AFE200-....	Dimensions: Width x Height x Depth		Weight	
	[mm]	[inches]	(kg)	(lbs)
3220	180 x 517 x 250.1	7.09 x 20.35 x 9.85	18	39,7
4450	268 x 616 x 270	10.55 x 24.25 x 10.63	24	52,9
5900	311 x 730.4 x 325	12.24 x 30.55 x 12.8	40	88,2
61320	421 x 924.5 x 360	16.57 x 36.4 x 14.17	68	149,9
71600	417 x 1407 x 485	16.42 x 55.4 x 19.1	120	264.6
72000			120	264.6
72500			130	286.6
73150			140	308,6
73550			140	308,6
400kW			837 x 1407 x 485	33.0 x 55.4 x 19.1
500kW	260	573,2		
630kW	280	617,3		
710kW	280	617,3		
900kW	1257 x 1407 x 485	49.5 x 55.4 x 19.1	420	925,9
1MW				
1.35MW	1677 x 1407 x 485	66.02 x 55.4 x 19.1	560	1234.6
1.65MW	2097 x 1407 x 485	82.56 x 55.4 x 19.1	700	1543.2

Note !

Weights referred to standard AFE with keypad, without options, packaging not included.

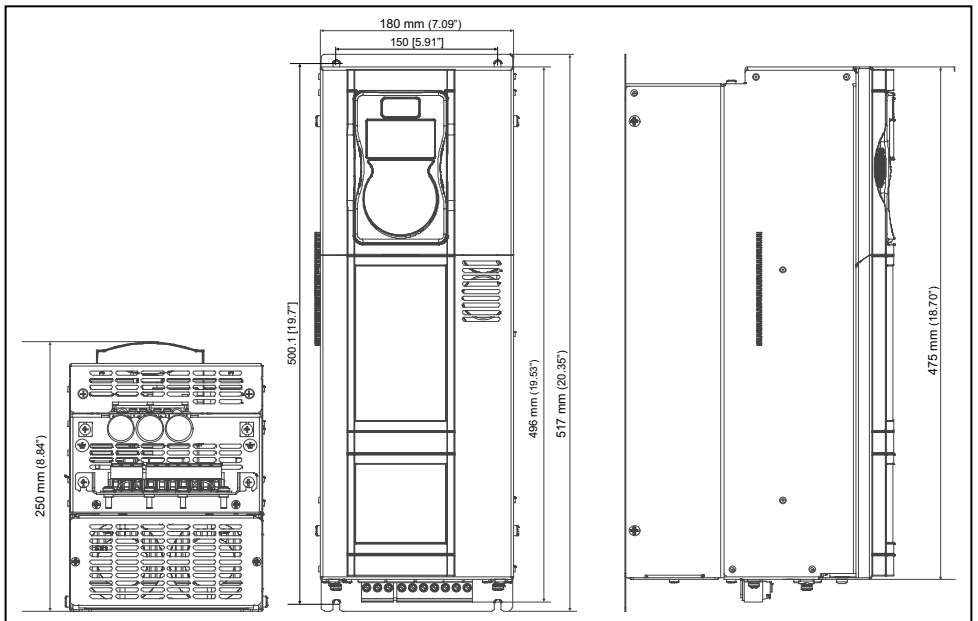

Figure 10.9.1: Size 3 dimensions

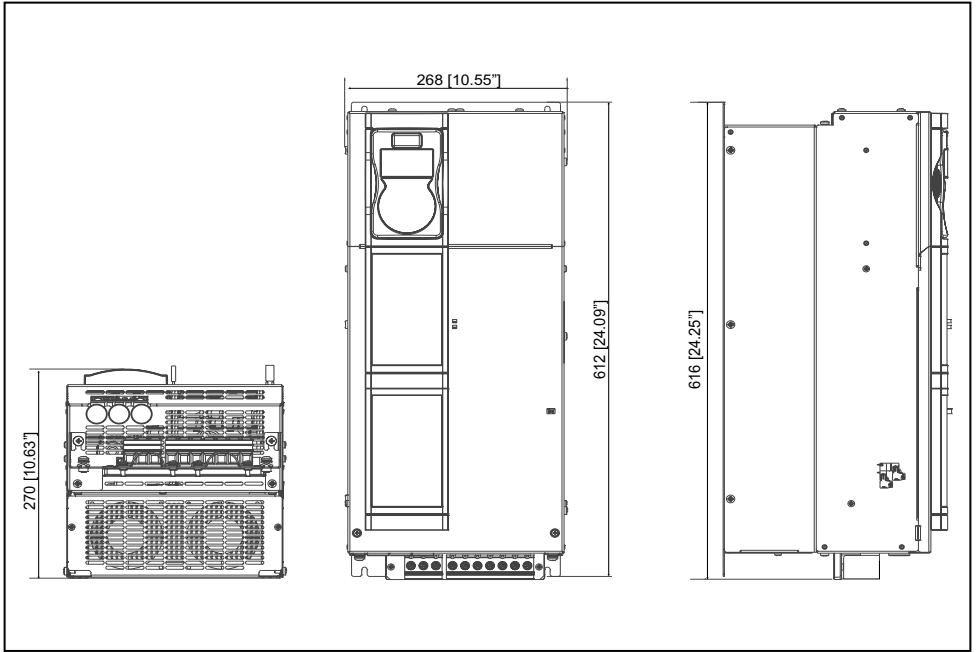

Figure 10.9.2: Size 4 dimensions

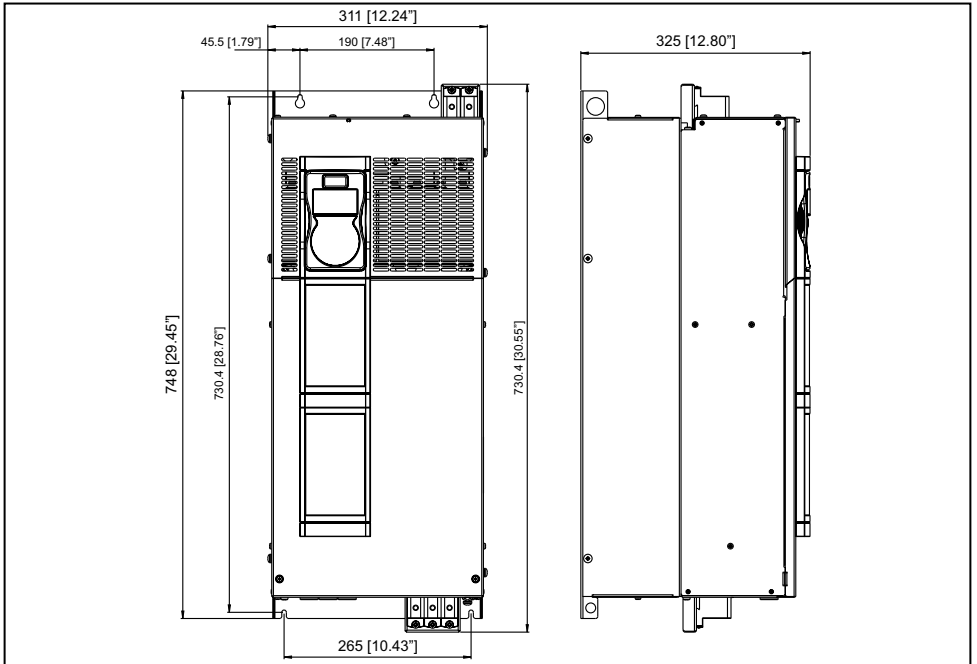

Figure 10.9.3: Size 5 dimensions

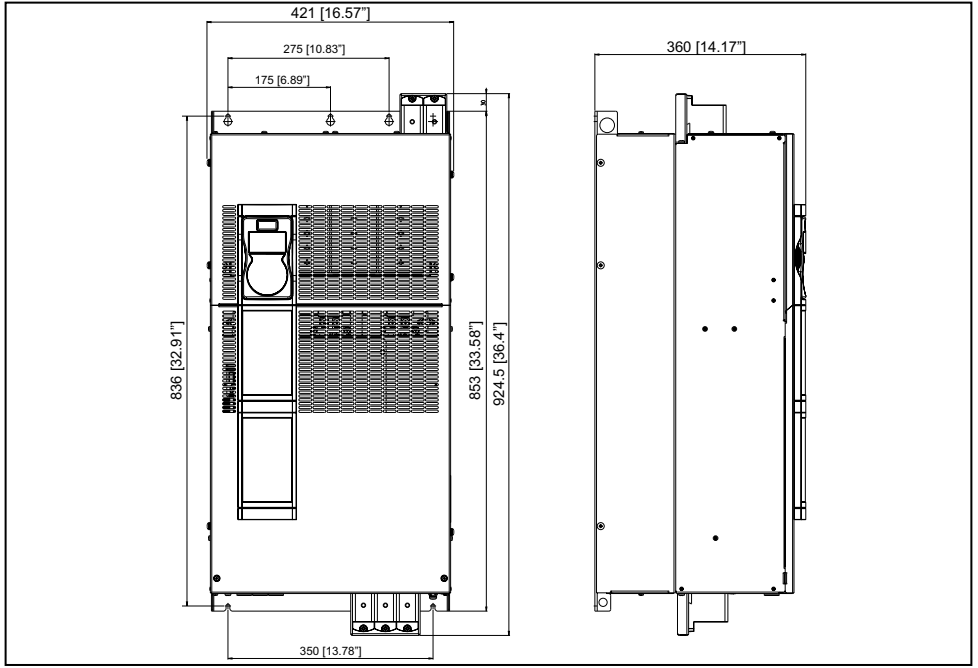

Figure 10.9.5: Size 6 dimensions

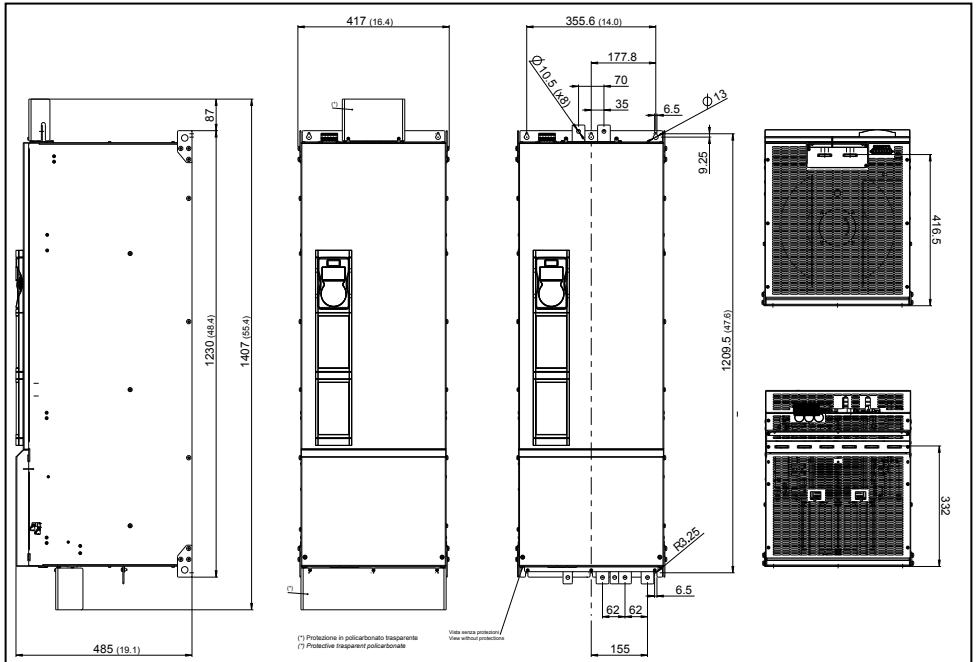

Figure 10.9.6: Size 7 dimensions

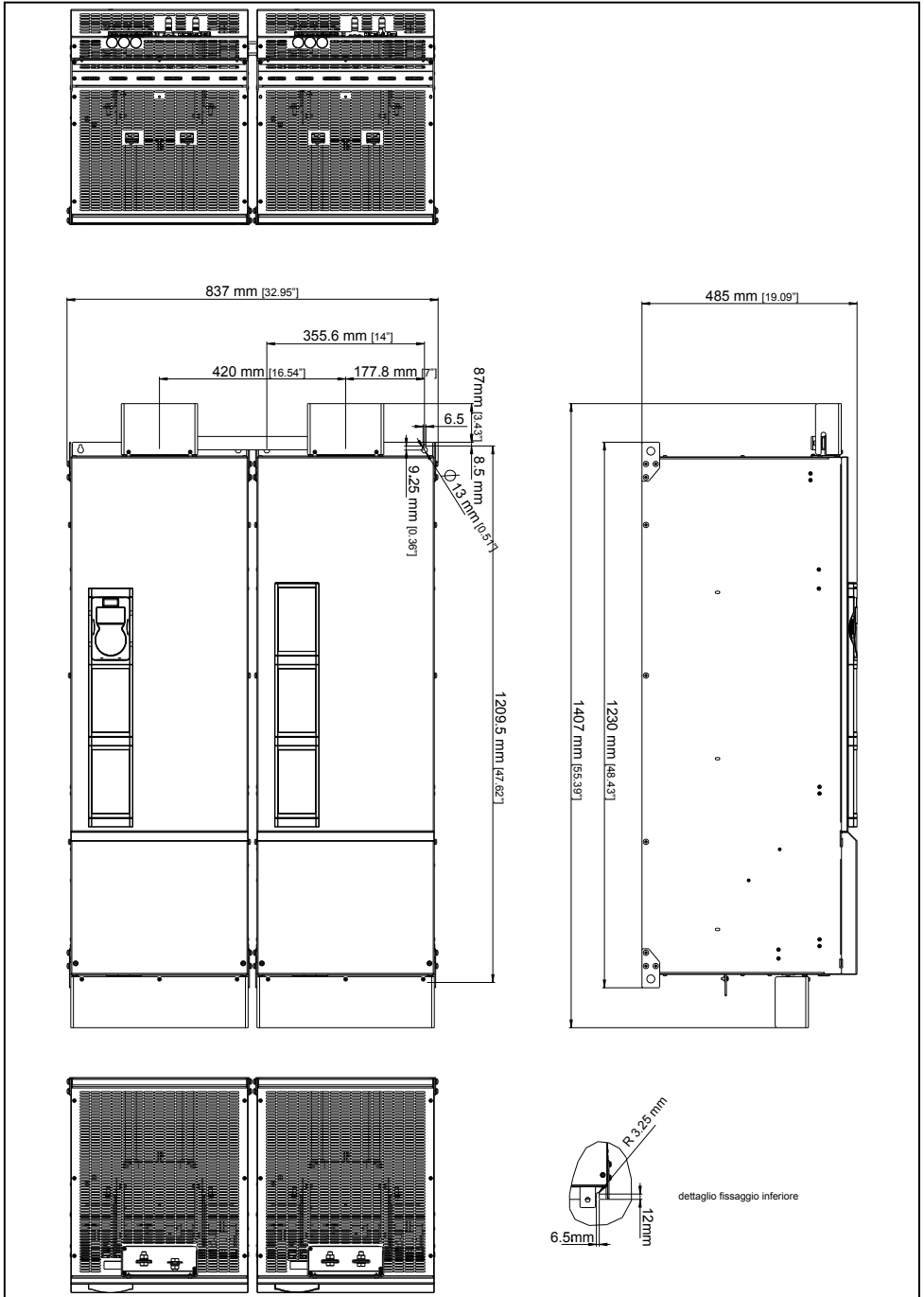

Figure 10.9.6: Sizes 400...710kW dimensions

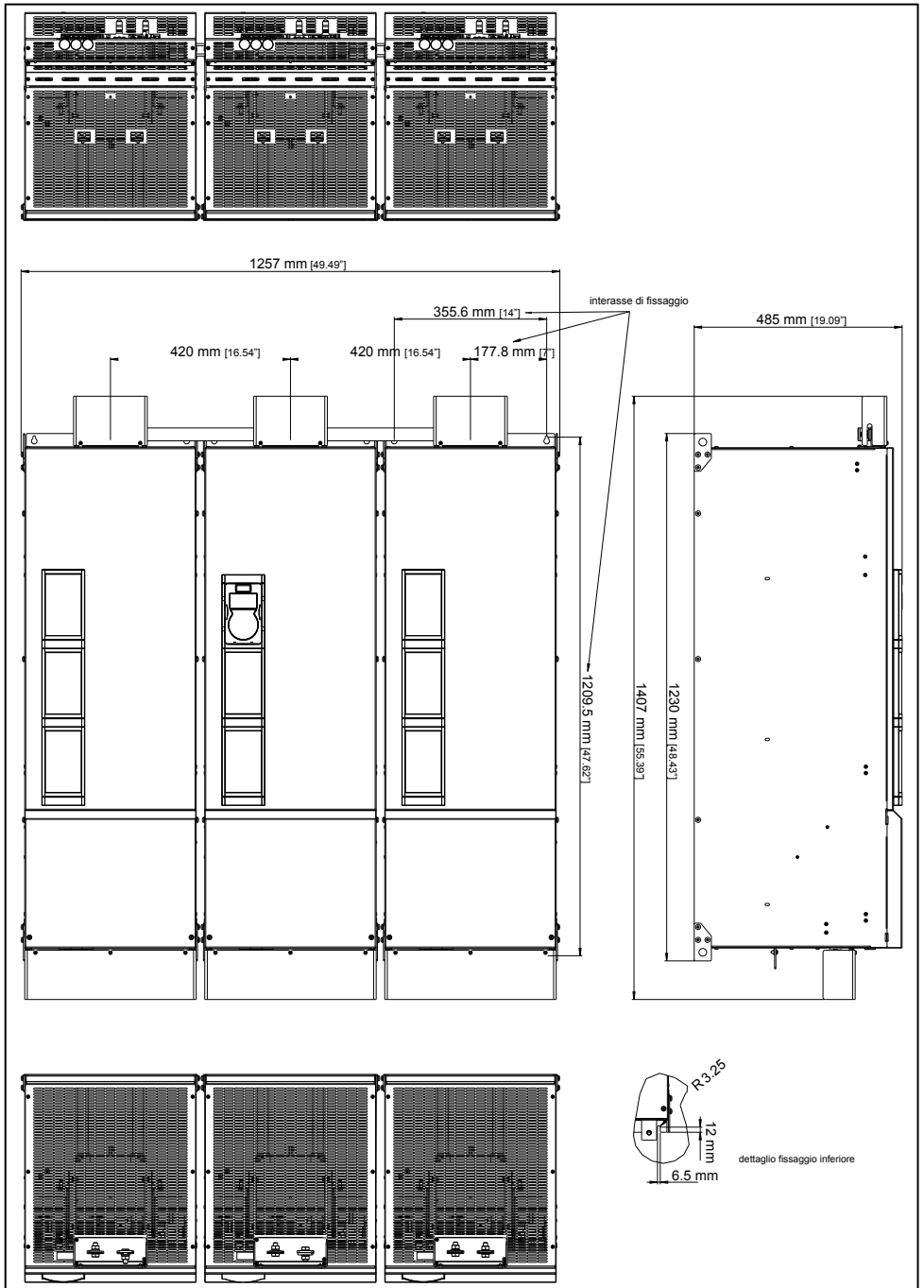

Figure 10.9.6: Size 900kW-1MW dimensions

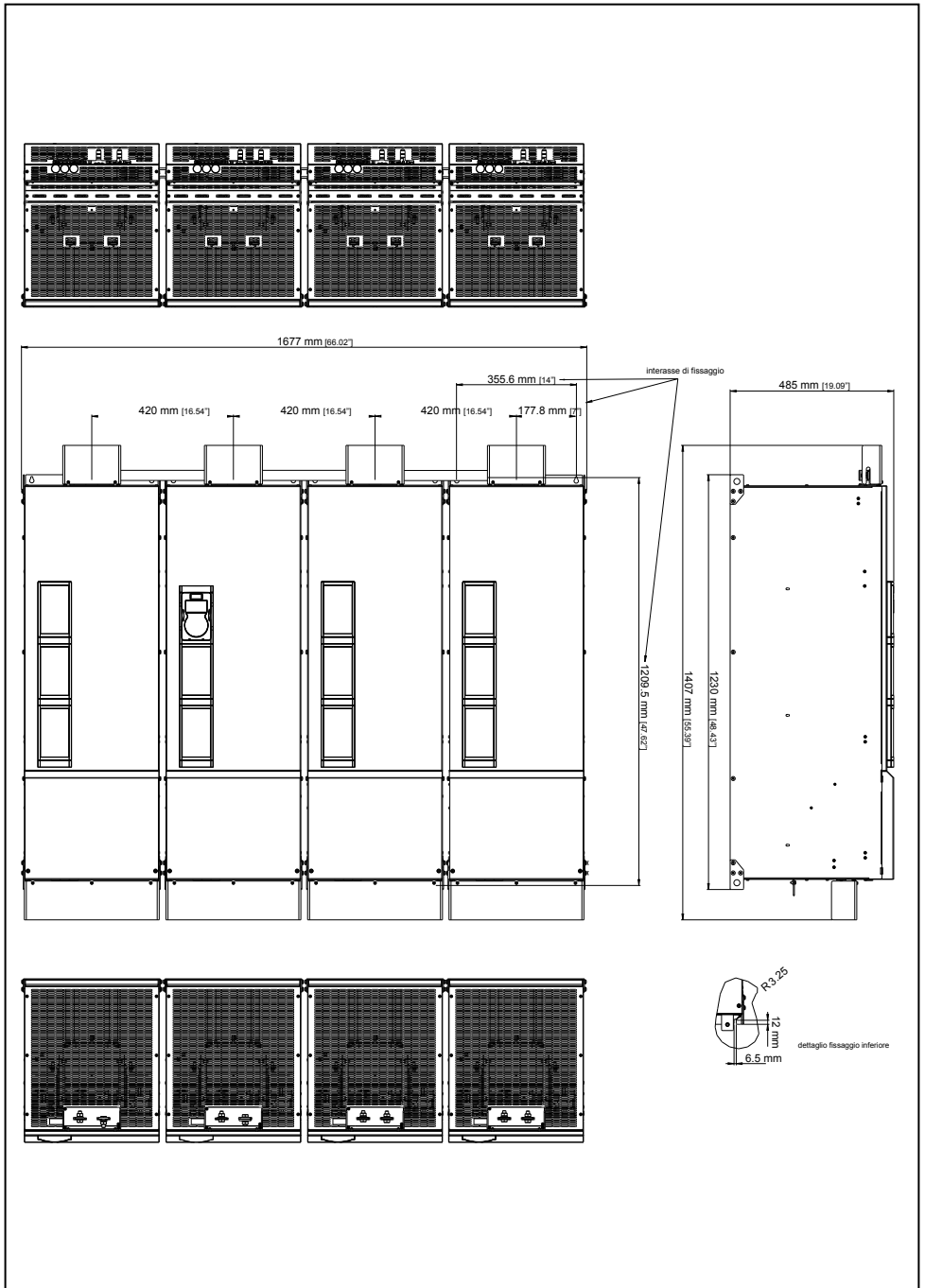

Figure 10.9.7: Size 1.35 MW dimensions

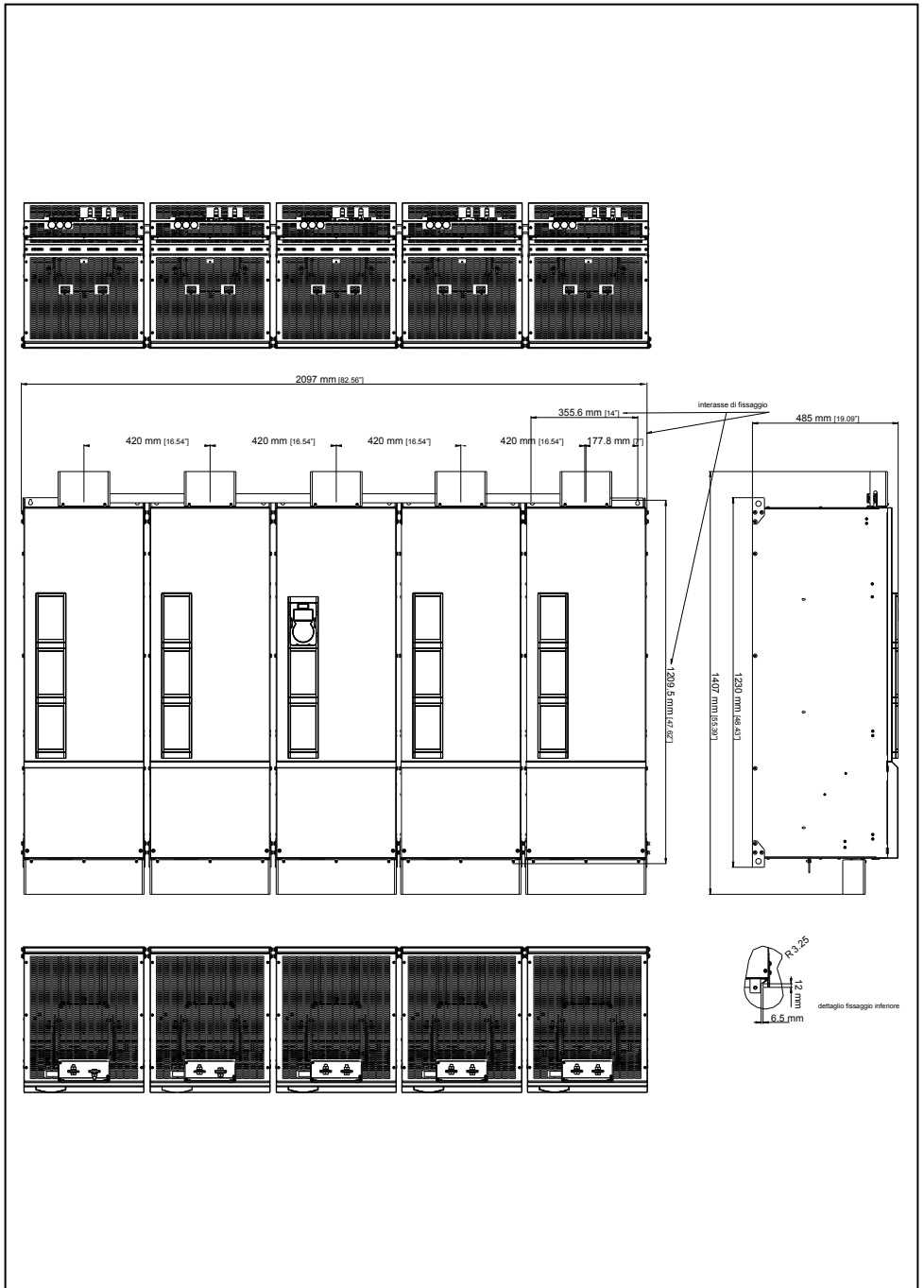

Figure 10.9.8: Size 1.65 MW dimensions

11 - Options

11.1 Optional external fuses (mandatory)

11.1.1 Fuses for connection mains side (F1)

Sizes AFE200-...-4		F1 - AC input side fuses			
		EUROPE		AMERICA	
		Type	Code	Type	Code
3220-4		S00C+/üf1/80A/690V	F4EAF	FWP-80B	S7G54
4450-4		S00C+/üf1/125A/690V	F4EAJ	FWP-150A	S7G56
5900-4		S1üf1/110/250A/690V	F4G28	FWP-250A	S7G59
61320-4		S1üf1/110/315A/690V	F4G30	FWP-350A	S7G61
71600-4		S2üf2/110/400A/690V	F4G34	FWP-400A	S7G62
72000-4		S2üf2/110/500A/690V	F4E30	FWP-500A	S7G63
72500-4		S2üf1/110/630A/690V	F4E31	FWP-600A	S7G65
73150-4		S3üf1/110/800A/690V	F4H02	FWP-800A	S7813
73550-4		S3üf1/110/800A/690V	F4H02	FWP-800A	S7813
400kW	72000-KXX-4-MS 04	S2üf2/110/500A/690V	F4E30	FWP-500A	S7G63
	72000-XXX-4-SL	S2üf2/110/500A/690V	F4E30	FWP-500A	S7G63
500kW	72500-KXX-4-MS 05	S2üf1/110/630A/690V	F4E31	FWP-600A	S7G65
	72500-XXX-4-SL	S2üf1/110/630A/690V	F4E31	FWP-600A	S7G65
630kW	73150-KXX-4-MS 06	S3üf1/110/800A/690V	F4H02	FWP-800A	S7813
	73150-XXX-4-SL	S3üf1/110/800A/690V	F4H02	FWP-800A	S7813
710kW	73550-KXX-4-MS 07	S3üf1/110/800A/690V	F4H02	FWP-800A	S7813
	73550-XXX-4-SL	S3üf1/110/800A/690V	F4H02	FWP-800A	S7813
900kW	73150-KXX-4-MS 09	S3üf1/110/800A/690V	F4H02	FWP-800A	S7813
	73150-XXX-4-SL	S3üf1/110/800A/690V	F4H02	FWP-800A	S7813
	73150-XXX-4-SL	S3üf1/110/800A/690V	F4H02	FWP-800A	S7813
1MW	73550-KXX-4-MS 10	S3üf1/110/800A/690V	F4H02	FWP-800A	S7813
	73550-XXX-4-SL	S3üf1/110/800A/690V	F4H02	FWP-800A	S7813
73550-XXX-4-SL		S3üf1/110/800A/690V	F4H02	FWP-800A	S7813

Sizes AFE200-...-6		F1 - External fuses for AC connection		
		EUROPE / AMERICA		
		Type	Type	Code
71600-6		20 613 32.315	170M4160	S85C20
72000-6		20 613 32.400	170M4162	S85C21
72500-6		20 623 32.500	170M5160	S8B21BF
73150-6		20 623 32.630	170M5162	S8B22BF
73550-6		20 623 32.630	170M5162	S8B22BF
400kW	72000-KXX-6-MS 04	20 613 32.400	170M4162	S85C21
	72000-XXX-6-SL	20 613 32.400	170M4162	S85C21
500kW	72500-KXX-6-MS 05	20 623 32.500	170M5160	S8B21BF
	72500-XXX-6-SL	20 623 32.500	170M5160	S8B21BF
630kW	73150-KXX-6-MS 06	20 623 32.630	170M5162	S8B22BF
	73150-XXX-6-SL	20 623 32.630	170M5162	S8B22BF
710kW	73550-KXX-6-MS 07	20 623 32.630	170M5162	S8B22BF
	73550-XXX-6-SL	20 623 32.630	170M5162	S8B22BF
900kW	73150-KXX-6-MS 09	20 623 32.630	170M5162	S8B22BF
	73150-XXX-6-SL	20 623 32.630	170M5162	S8B22BF
	73150-XXX-6-SL	20 623 32.630	170M5162	S8B22BF

Sizes AFE200-...-6		F1 - External fuses for AC connection		
		EUROPE / AMERICA		
		Type	Type	Code
1MW	73550-KXX-6-MS 10	20 623 32.630	170M5162	S8B22BF
	73550-XXX-6-SL	20 623 32.630	170M5162	S8B22BF
	73550-XXX-6-SL	20 623 32.630	170M5162	S8B22BF
1,35MW	73550-KXX-6-MS 14	20 623 32.630	170M5162	S8B22BF
	73550-XXX-6-SL2	20 623 32.630	170M5162	S8B22BF
	73550-XXX-6-SL	20 623 32.630	170M5162	S8B22BF
1,65MW	73550-KXX-6-MS 17	20 623 32.630	170M5162	S8B22BF
	73550-XXX-6-SL2	20 623 32.630	170M5162	S8B22BF
	73550-XXX-6-SL2	20 623 32.630	170M5162	S8B22BF
	73550-XXX-6-SL	20 623 32.630	170M5162	S8B22BF
	73550-XXX-6-SL	20 623 32.630	170M5162	S8B22BF

The technical data of the fuses, e.g. dimensions, weights, heat dissipation, auxiliary contactors, are reported in the corresponding manufacturer data sheets. S... (Jean Müller), FWP... / 170M... (Bussmann), 20... (SIBA).

11.1.2 Fuses for connection DC side

Sizes AFE200-...-4		F2 - External fuses for DC connection		
		EUROPE / AMERICA		
		Type	Type	Code
	3220-4	-	-	-
	4450-4	-	-	-
	5900-4	-	-	-
	61320-4	-	-	-
	71600-4	-	-	-
	72000-4	-	-	-
	72500-4	-	-	-
	73150-4	-	-	-
	73550-4	-	-	-
400kW	72000-KXX-4-MS 04	20 623 32.630	170M5162	S8B22BF
	72000-XXX-4-SL	20 623 32.630	170M5162	S8B22BF
500kW	72500-KXX-4-MS 05	20 623 32.800	170M5164	S8B23BF
	72500-XXX-4-SL	20 623 32.800	170M5164	S8B23BF
630kW	73150-KXX-4-MS 06	20 623 32.1000	170M5166	S8B24BF
	73150-XXX-4-SL	20 623 32.1000	170M5166	S8B24BF
710kW	73550-KXX-4-MS 07	20 623 32.1000	170M5166	S8B24BF
	73550-XXX-4-SL	20 623 32.1000	170M5166	S8B24BF
900kW	73150-KXX-4-MS 09	20 623 32.1000	170M5166	S8B24BF
	73150-XXX-4-SL	20 623 32.1000	170M5166	S8B24BF
	73150-XXX-4-SL	20 623 32.1000	170M5166	S8B24BF
1MW	73550-KXX-4-MS 10	20 623 32.1000	170M5166	S8B24BF
	73550-XXX-4-SL	20 623 32.1000	170M5166	S8B24BF
	73550-XXX-4-SL	20 623 32.1000	170M5166	S8B24BF

The technical data of the fuses, e.g. dimensions, weights, heat dissipation, auxiliary contactors, are reported in the corresponding manufacturer data sheets. 170M... (Bussmann), 20... (SIBA).

Sizes AFE200-...-6	F2 - External fuses for DC connection			
	EUROPE / AMERICA			
	Type	Type	Code	
71600-6	-	-	-	
72000-6	-	-	-	
72500-6	-	-	-	
73150-6	-	-	-	
73550-6	-	-	-	
400kW	72000-KXX-6-MS 04	20 733 32.500	170M6142	S85C14
	72000-XXX-6-SL	20 733 32.500	170M6142	S85C14
500kW	72500-KXX-6-MS 05	20 733 32.630	170M6144	S85C15
	72500-XXX-6-SL	20 733 32.630	170M6144	S85C15
630kW	73150-KXX-6-MS 06	20 733 32.700	170M6145	S85C16
	73150-XXX-6-SL	20 733 32.700	170M6145	S85C16
710kW	73550-KXX-6-MS 07	20 733 32.800	170M6146	S85C17
	73550-XXX-6-SL	20 733 32.800	170M6146	S85C17
900kW	73150-KXX-6-MS 09	20 733 32.700	170M6145	S85C16
	73150-XXX-6-SL	20 733 32.700	170M6145	S85C16
	73150-XXX-6-SL	20 733 32.700	170M6145	S85C16
1MW	73550-KXX-6-MS 10	20 733 32.800	170M6146	S85C17
	73550-XXX-6-SL	20 733 32.800	170M6146	S85C17
	73550-XXX-6-SL	20 733 32.800	170M6146	S85C17
1,35MW	73550-KXX-6-MS 14	20 733 32.800	170M6146	S85C17
	73550-XXX-6-SL2	20 733 32.800	170M6146	S85C17
	73550-XXX-6-SL	20 733 32.800	170M6146	S85C17
	73550-XXX-6-SL	20 733 32.800	170M6146	S85C17
1,65MW	73550-KXX-6-MS 17	20 733 32.800	170M6146	S85C17
	73550-XXX-6-SL2	20 733 32.800	170M6146	S85C17
	73550-XXX-6-SL2	20 733 32.800	170M6146	S85C17
	73550-XXX-6-SL	20 733 32.800	170M6146	S85C17
	73550-XXX-6-SL	20 733 32.800	170M6146	S85C17

Note !

For size 7 only, adaptation for internal mounting of fuses (DC side) on request.

The technical data of the fuses, e.g. dimensions, weights, heat dissipation, auxiliary contactors, are reported in the corresponding manufacturer data sheets. 170M... (Bussmann), 20... (SIBA).

11.2 EMC filter

EN 61800-3 : Category C3, 2nd Environment / 50 m Motor cable length.



AFE200-4 - Heavy Duty

Filter type	Code	Dimensions : WxHxd (mm)	Weight (kg)																
				22kW	45kW	90kW	132kW	160kW	200kW	250kW	315kW	355kW	400kW	500kW	630kW	710kW	900kW	1 MW	
EMI FN3120 - 480 - 50	S7DGV	214 x 159 x 64	2.7	1															
EMI FN3120 - 480 - 80	S73EE	221 x 169 x 140	5.0		1														
EMI FN3120 - 480 - 230	S74EE	300 x 168 x 140	13.3			1	1												
EMI FN3359 - 480 - 320	S7GOH	440 x 122 x 260	10.5					1											
EMI FN3359 - 480 - 400	S7GHY	440 x 122 x 260	10.5						1				2						
EMI FN3359 - 480 - 600	S7GHW	440 x 142 x 260	11.0							1	1	1		2	2	2	3	3	



AFE200-4 - Low Duty

Filter type	Code	Dimensions : WxHxd (mm)	Weight (kg)																	
				22kW	45kW	90kW	132kW	160kW	200kW	250kW	315kW	355kW	400kW	500kW	630kW	710kW	900kW	1 MW		
EMI FN3120 - 480 - 80	S73EE	221 x 169 x 140	5.0	1																
EMI FN3120 - 480 - 110	S7DGZ	221 x 169 x 140	6.1		1															
EMI FN3120 - 480 - 230	S74EE	300 x 168 x 140	13.3			1														
EMI FN3359 - 480 - 320	S7GOH	440 x 122 x 260	10.5				1													
EMI FN3359 - 480 - 400	S7GHY	440 x 122 x 260	10.5					1	1				2							
EMI FN3359 - 480 - 600	S7GHW	440 x 142 x 260	11.0							1	1	1		2	2	2	3	3		

Note !

AFE200-4 filters for connection to TT and TN networks (filters for IT network on request).



AFE200-6 - High & Low Duty

Filter type	Code	Dimensions : WxHxd (mm)	Weight (kg)																	
				160kW	200kW	250kW	315kW	355kW	400kW	500kW	630kW	710kW	900kW	1 MW	1.35 MW	1.65 MW				
EMI-FN3359HV-690-150	S7EMI13	420 x 127 x 210	6.5	1																
EMI-FN3359HV-690-180	S7EMI14	420 x 127 x 210	6.5		1					2										
EMI-FN3359HV-690-250	S7EMI15	420 x 132 x 230	7.0			1					2									
EMI-FN3359HV-690-320	S7EMI16	440 x 122 x 260	10.5				1	1				2	2	3	3	4	5			

Note !

AFE200-6 filters for connection to TT, TN and IT networks.

11.3 Installation of optional cards

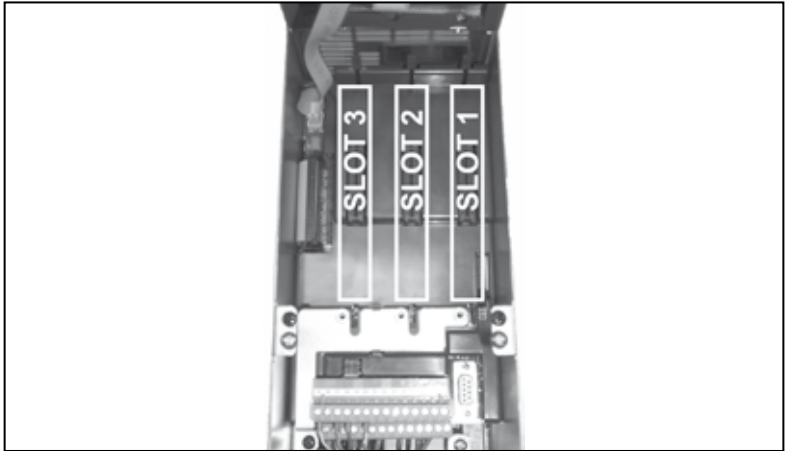

Up to three optional cards can be inserted in the three slots under the top cover (EXP-SYNC-ADV card is mounted as standard):

- **Slot 1:** dedicated to IO and CAN/DeviceNet cards (EXP-IO-...-ADV, EXP-CAN-ADV)
- **Slot 2:** Reserved for the EXP-SYNC-ADV card
- **Slot 3:** dedicated to field Bus cards (EXP-PDP-ADV, EXP-CAN-ADV, ecc)

If both I/Os card and CAN/DeviceNet field bus card are needed, below special configuration can be used:

- **Slot 1:** EXP-SYNC-ADV
- **Slot 2:** EXP-IO-...-ADV
- **Slot 3:** EXP-CAN-ADV



Attention

.....
If an optional card is inserted in an incorrect Slot, the AFE will send an error message.
.....

1. Remove the bottom cover as indicated in [paragraph 5.2.1](#).

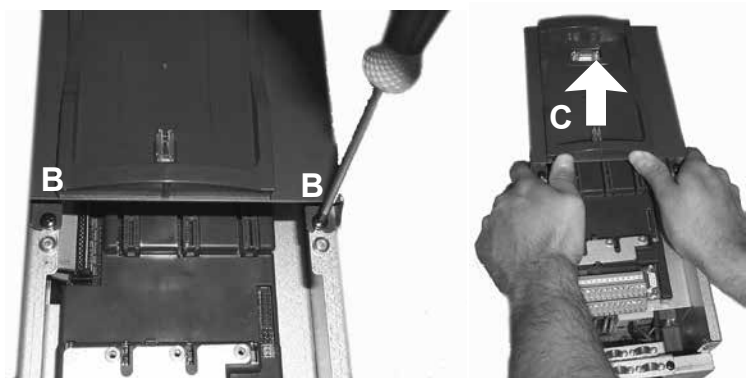

2. To remove the top cover, loosen screws B by about 2 turns and slide out cover C as shown in the figure.

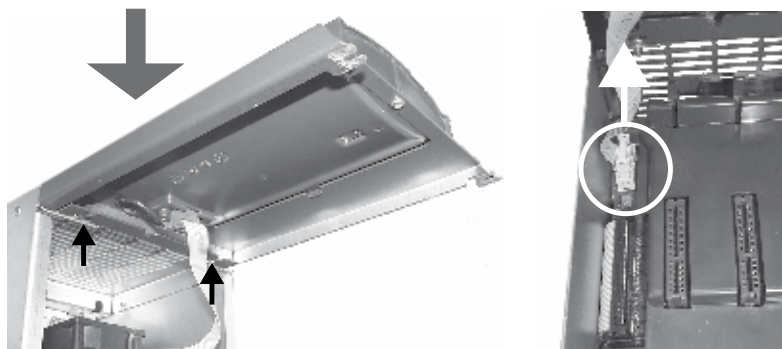

3. To prevent damage to the connection of the keypad, the top cover can be positioned as indicated in the figure. Alternatively, remove the connector of the keypad and rest the cover in a safe place.

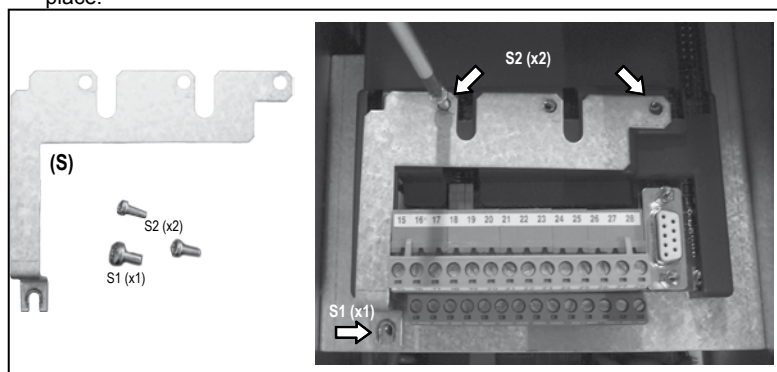

4. Position and fasten the metallic shield (S), provided with the optional card, with the screws S1 and S2 (x1) as shown in the figure.

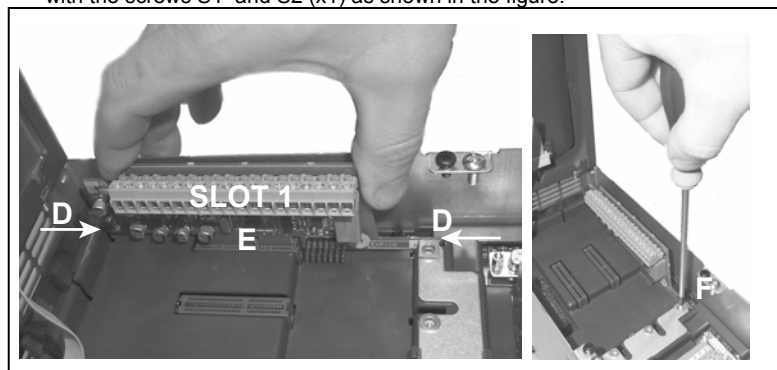

5. Position the optional card in the dedicated Slot (in the example, the EXP-IO



card is inserted in Slot 1).

Align the ends of the card (D) in the slots and then fully insert the connector of the card in the connectors of the AFE (E).

6. Fasten the card with the screw + washer (provided with the optional card) in housing (F) as shown in the figure

11.4.1 Shielding of optional card connections

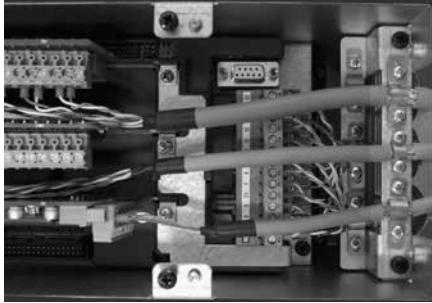

Fasten the shield of the cables to the omega sections as showed on figure.



Appendix 1 - Design

AFE200 product are normally used in applications that require the re-introduction of power into the mains. They can also be used when regeneration is not required, to achieve unitary cos phi or low total harmonic distortion values (which standard inverters do not guarantee, even with a DC or line choke).

This section provides some examples of design, from the simplest, single-motor configuration to more complex ones.

As a general rule, the AFE2000 should be at least the same size as the drive, which is usually an ADV200-DC.

In certain cases the size can be chosen according to the work cycles and load profiles of each drive, in both motor or generator mode.

Another calculation to be performed is the sum of the loads connected to the DC-LINK, obtained from the total of the parallel connections.

The sum of the loads of each drive must be less than the maximum value specified (see table 10.4) in order to guarantee correct pre-load circuit operation.

Precharge kit must be selected according to AFE size and the capacity connected to the DC-Link (see chapter "5.5 Precharge Kit" on page 48).

LCL Filter must be selected considering the use of the AFE: Heavy Duty or Low Duty overload (see chapter "5.6 LCL Filters" on page 51).

Key to symbols:

P_{OUTM} = Motor output power (continuous operation)

V_{OUTM} = Motor voltage rating

V_{MAINS} = AC mains supply voltage rating

η_M = Typical motor efficiency

η_D = Typical drive efficiency (0.97)

P_{DC} = Power requested by the DC-link

I_m Motor rated current

V_{dlink} DC-link rated voltage

650Vcc at 400Vac

750Vcc at 460Vac

930Vcc at 575Vac

1120Vcc at 690Vac

Note!

For special applications please contact technohelp@gefran.com.

A1.1 Single-motor calculation based on motor output power

Mains: V_{mains} = three-phase 400Vca

Motor: P_{OUTM} = 132kW

V_{OUTM} = 400Vca

η_M = 0.95;

I_M = 236A

Application: Requires 100% of motor power

Requested overload = 150%

> **Calculation of the current required on the DC-link:**

$$P_{DC} = \frac{P_{OUTM} \text{ [kW]} \quad 132 * 1000}{V_{dlink} * \eta_M * \eta_D \quad 650 * 0.95 * 0.97} = 220 \text{ A}$$

> **Choosing the power supply unit:**

The AFE200 must be capable of delivering a current of $\geq 220 \text{ A}$

Choose the size with the appropriate characteristics from the section **"10.6 Electrical data" on page 170:**

AFE200-61320.

> **Choosing the drive:**

Choose the size with the rated current required by the motor ($\geq 236\text{A}$) from the catalogue (section ADV200-DC "2.7 Output Data"):

With a 650 Vdc drive:

ADV-71600-...-DC (In = 270A, OK).

Drive	Description	Code	Q.ty
ADV200-DC	ADV-71600-KXX-4-DC	S9O20DC	1

AFE + components	Description	Code	
AFE Regen unit	AFE200-61320-KXX-4	S9AF04	1
Pre-charge kit	PRE CHARGE KIT-AFE-90/132-4	S728281	1
LCL KIT	LCL-Kit-AFE-4-132-HD	S7LC03	1
EMI filter	EMI FN3120 -480V-230A	S74EE	1
Fuses mains side connection	S1üf1/110/315A/690V	F4G30	3

Checking total DC-link capacity:

AFE200-61320 with ADV-71600-...-4-DC = 13600 + 16800 = 30400 $\mu\text{F} \leq 43000 \mu\text{F}$ (OK). See table on page 48.

A1.2 Calculation for multi-motor system

Mains: $V_{MAINS} = \text{three-phase } 400\text{Vac}$

Motor 1: $P_{OUTM} = 18.5\text{kW}$
 $V_{OUTM} = 400\text{V}_{CA}$
 $\eta_M = 0.95$
 $I_M = 37\text{A}$
 Application: continuous load, $P_{cont} = 85\%$
 Requested overload = 130%

Motor 2: $P_{OUTM} = 18.5\text{kW}$
 $V_{OUTM} = 400\text{V}_{CA}$
 $\eta_M = 0.95$
 $I_M = 37\text{A}$
 Application: continuous load, $P_{cont} = 90\%$
 Requested overload = 130%

Motor 3: $P_{OUTM} = 22\text{kW}$
 $V_{OUTM} = 400\text{V}_{CA}$

$\eta_M = 0,96$
 $I_M = 43A$
 Application: continuous load, $P_{cont} = 80\%$
 Requested overload = 130%

> Total electrical power absorbed:

$$P_{TOT} = \frac{(P_{OUTM} * P_{CONT})}{\eta_M}$$

$$P_{TOT} = \frac{(18.5 * 0.85)}{0.95} + \frac{(18.5 * 0.9)}{0.95} + \frac{(22 * 0.8)}{0.96} = 52.4 \text{ kW}$$

> Total power requested by the DC-link side:

$$P_{DC} = \frac{P_{TOT}}{\eta_D} + \frac{52.4}{0.97} = 54 \text{ kW}$$

400 Vac mains, corresponding DC-link value = 650Vcc

$$I_{TOT} = \frac{P_{DC} * 1000}{V_{dc-link}} + \frac{54000}{650} = 83 \text{ A}$$

$$I_{MAX} = \frac{(P_{OUTM} * I_{OVLD})}{V_{dc-link} * \eta_M} = \frac{(18500 * 1.3)}{650 * 0.95} + \frac{(18500 * 1.3)}{650 * 0.95} + \frac{(22000 * 1.3)}{650 * 0.96} = 123 \text{ A}$$

The AFE200 must be able to deliver a current of $\geq 83A$ with an overload current value of $\geq 123A$.

Choose the size with the appropriate characteristics from the section **"10.6 Electrical data" on page 170**:

AFE200 - 4450.

> Choosing the drive:

Since the motors are used at below the rated power, the following inverters are suitable:

Motor 1 : $I_{M1} = 37A * 85\% = 31.4A$

Choose the size with the rated current required by the motor ($\geq 31.4A$) from the catalogue ADV & AFE (section ADV200-DC "2.7 Output Data").

With a 650 Vdc drive:

ADV-3185-....-DC ($I_n = 34.2A$, OK).

Motor 2 : $I_{M2} = 37A * 90\% = 33.3A$

Choose the size with the rated current required by the motor ($\geq 33.3A$) from the catalogue ADV & AFE (section ADV200-DC "2.7 Output Data").

With a 650 Vdc drive:

ADV-3185-....-DC ($I_n = 34.2A$, OK).

Motor 3 : $I_{M3} = 43A * 80\% = 34.4A$

Choose the size with the rated current required by the motor ($\geq 34.4A$) from the

catalogue ADV & AFE (section ADV200-DC “2.7 Output Data”).

With a 650 Vdc drive:

ADV-3220-...-DC (In = 41.4A, OK).

Drive	Description	Code	Q.ty
ADV200-DC	ADV-3185-KXX-4-DC	S9010DC	2
ADV200-DC	ADV-3220-KXX-4-DC	S9011DC	1
Fuses for connection DC side	S00C+/üf1/80A/690V	F4EAF	6

AFE + components	Description	Code	
AFE Regen unit	AFE200-4450-KXX-4	S9AF02	1
Pre-charge kit	PRE CHARGE KIT-AFE-22/45-4	S72828	1
LCL KIT	LCL-Kit-AFE-4-45-HD	S7LC01	1
EMI filter	EMI FN3120-480-80	S73EE	1
Fuses mains side connection	S00C+/üf1/125A/690V	F4EAJ	3

Precharge kit size

DC-Link total capacity:

(ADV-3185-KXX-4-DC * 2) 1500*2 + (ADV-3220-KXX-4-DC) 1500 + (AFE200-4450-KXX-4) 3400 = 7900 µF

The standard precharge kit for AFE200-4450-KXX-4 is **PRE-CHARGE KIT-AFE-22/45-4**.

As per the table on page 48, the maximum controllable capacity is 21500 µF: 7900 µF ≤ 21500 µF (OK).

Appendix 2 - Parallel connection (400 ... 1650kW sizes)

A 2.1 Introduction

To obtain an AFE of more than 355 kW connect a number of single units of between 200 kW and 355 kW in parallel.

A parallel connection of several units basically consists of one MASTER unit and one or more SLAVE units.

Power	code	Description (Designation)
400kW	S9AF21M	AFE200-72000-KXX-4-MS 04
	S9AF21S	AFE200-72000-KXX-4-SL
500kW	S9AF22M	AFE200-72500-KXX-4-MS 05
	S9AF22S	AFE200-72500-KXX-4-SL
630kW	S9AF23M	AFE200-73150-KXX-4-MS 06
	S9AF23S	AFE200-73150-KXX-4-SL
710kW	S9AF24M	AFE200-73550-KXX-4-MS 07
	S9AF24S	AFE200-73550-KXX-4-SL
900kW	S9AF231	AFE200-73150-KXX-4-MS 09
	S9AF23S	AFE200-73150-KXX-4-SL
	S9AF23S	AFE200-73150-KXX-4-SL
1MW	S9AF241	AFE200-73550-KXX-4-MS 10
	S9AF24S	AFE200-73550-KXX-4-SL
	S9AF24S	AFE200-73550-KXX-4-SL

Power	code	Description (Designation)
400kW	S9AF51M	AFE200-72000-KXX-6-MS 04
	S9AF51S	AFE200-72000-KXX-6-SL
500kW	S9AF52M	AFE200-72500-KXX-6-MS 05
	S9AF52S	AFE200-72500-KXX-6-SL
630kW	S9AF53M	AFE200-73150-KXX-6-MS 06
	S9AF53S	AFE200-73150-KXX-6-SL
710kW	S9AF54M	AFE200-73550-KXX-6-MS 07
	S9AF54S	AFE200-73550-KXX-6-SL
900kW	S9AF53M1	AFE200-73150-KXX-6-MS 09
	S9AF53S	AFE200-73150-KXX-6-SL
	S9AF53S	AFE200-73150-KXX-6-SL
1MW	S9AF54M1	AFE200-73550-KXX-6-MS 10
	S9AF54S	AFE200-73550-KXX-6-SL
	S9AF54S	AFE200-73550-KXX-6-SL
1.35MW	S9AF54M4	AFE200-73550-KXX-6-MS 14
	S9AF54S	AFE200-73550-KXX-6-SL
	S9AF54S2	AFE200-73550-KXX-6-SL2
1.65MW	S9AF54M5	AFE200-73550-KXX-6-MS 17
	S9AF54S	AFE200-73550-KXX-6-SL
	S9AF54S	AFE200-73550-KXX-6-SL
	S9AF54S2	AFE200-73550-KXX-6-SL2
	S9AF54S2	AFE200-73550-KXX-6-SL2

Master unit

this is the only one to have the regulation card and keypad. It differs from the standard single unit in that the power section control card (INT-P-ADV) is re-configured to function as MASTER and includes one or more MASTER - SLAVE (INT-SLAVE) interface cards, one card for each slave that is connected.

The MASTER - SLAVE interface is achieved via a specific signal cable included in the SLAVE AFE packaging.

Slave unit

It differs from the standard single unit in that it has a dedicated power section control card (INT-P-ADV) and there is no regulation card or keypad.

INT-P-ADV-MASTER card

The INT-P-ADV-MASTER card provided with one or more INT-SLAVE cards, acts as the interface between the R-ADV regulation card and the power section of the master unit and all the slave units. It also performs the following functions:

- current signal scaling (via dip switch, factory-set)
- hardware dead time compensation
- alarm signal management (including local diagnostics via LED)
- temperature signal management.

INT-P-ADV-SLAVE card

The INT-P-ADV-SLAVE card interfaces between the power section of the slave unit and the master unit. It also performs the following functions:

- alarm signal management (including local diagnostics via LED)
- temperature signal management.

INT-SLAVE card

The INT-SLAVE interface card manages communication between a master unit and a slave unit.

The INT-SLAVE cards are mounted on the master unit, their number corresponding to that of the slaves that are connected (max. 4 slaves).

The INT-SLAVE card is factory-set.

A 2.2 Compatibility of IGBT modules

Starting from July 2015, the following 690V products based on power stack 315kW and 355kW, which use IGBT modules "INFINEON" branded, will be manufactured with power modules "FUJI" branded too. Both types have same mechanical dimensions but they cannot be combined together.

MODEL	Code	Type
INFINEON	S8HRS20	MODULE-IGBT6-1K7V 450A
FUJI	S8HRS44	MODULE-IGBT6-1K7V 450A

Code	Type	Product configuration with Module INFINEON	Product configuration with Module FUJI
S9AF53	AFE200-73150-KXX-6	A1...B2	B3
S9AF53M	AFE200-73150-KXX-6-MS 06		
S9AF53M1	AFE200-73150-KXX-6-MS 09		
S9AF53S	AFE200-73150-KXX-6-SL		
S9AF54	AFE200-73550-KXX-6		
S9AF54M	AFE200-73550-KXX-6-MS 07		
S9AF54M1	AFE200-73550-KXX-6-MS 10		
S9AF54M4	AFE200-73550-KXX-6-MS 14		
S9AF54M5	AFE200-73550-KXX-6-MS 17		
S9AF54S2	AFE200-73550-KXX-6-SL2		



When replacing the IGBT modules on an existing product, it must be checked the "Prod Configuration" on the label for the correct replacement. IGBT module installed in the drive must be all the same type. See "Firmware & cards revision" in chapter **"2.1 Product type designation" on page 12**.



The following rules must be strictly followed:

- IGBT modules installed in the drive must be all same type / typology.
- Master / Slave products configuration must necessarily be made with the same IGBT type. It will be not possible to use drive with different product configuration between master and slave.
- For repair in field, the replacement of an IGBT module may be carry out with same type. It will be not possible to use drive Master with Infineon power module and drive Slave with Fuji power module and vice versa.

A 2.3 MS-SL interface cable wiring sizes 400...710 kW

Fit the AFE200 MASTER and SLAVE power supplier units inside the electrical panel. Connect all the power section cables and connect the signal cable for interfacing between the 2 AFE200.



The cable (code 8S860B) for connecting 2 AFE200 is one meter long and has two quick coupling male MDR connectors at the ends.

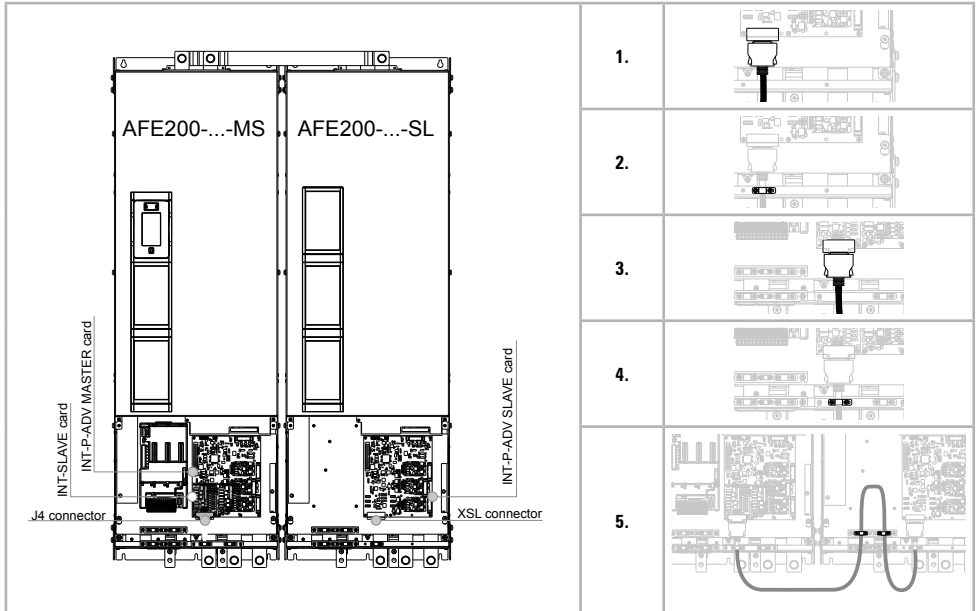

Wiring instructions:

1. Connect one of the 2 ends of the interface cable to the XSL connector of the INT-P-ADV-SLAVE card.
2. Secure the cable using the specific clamp.
3. Connect the other end of the cable to connector J4 of the INT-SLAVE card mounted on the INT-P-ADV-MASTER card of the MASTER AFE.
4. Secure the cable in the relative clamp
5. To prevent the interface cable from coming into contact with the power terminals, fold the excess length of cable inside the SLAVE AFE as shown in the figure and secure it using the specific cable clamps.

A 2.4 MS-SL interface cable wiring sizes 900 kW...1 MW

Fit the AFE200 MASTER and SLAVE power supplier inside the electrical panel.
Connect all the power section cables and connect the 2 signal cables for interfacing between the 3 AFE200.



The cable (code 8S860B, x 2) for connecting the AFE200 is one meter long and has two quick coupling male MDR connectors at the ends.

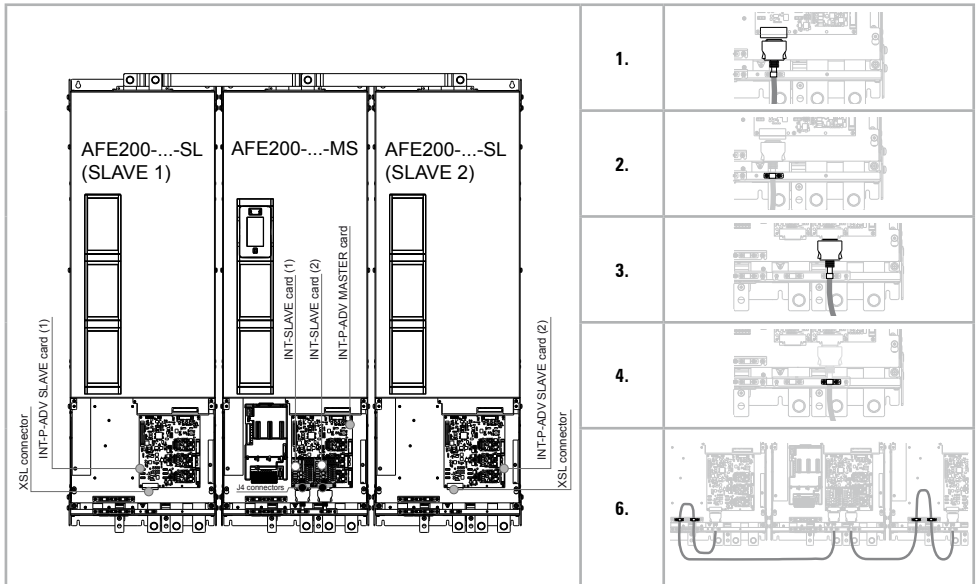

Wiring instructions:

1. Connect one of the 2 ends of the interface cable to the XSL connector of the INT-P-ADV-SLAVE (SLAVE 2) card.
2. Secure the cable using the specific clamp.
3. Connect the other end of the cable to connector J4 of the INT-SLAVE (2) card mounted on the INT-P-ADV-MASTER card of the MASTER AFE.
4. Secure the cable in the relative clamp
5. Repeat steps 1-2-3-4 for SLAVE 1.
6. To prevent the interface cables from coming into contact with the power terminals, fold the excess length of cable inside the SLAVE AFE as shown in the figure and secure it using the specific cable clamps.

A 2.5 MS-SL interface cable wiring size 1.35 MW

Fit the AFE200 MASTER and SLAVE power supplier inside the electrical panel.
Connect all the power section cables and connect the 3 signal cables for interfacing between the 4 AFE200.



The cables (code 8S860B x 2 + code 8S870B x 1) for connecting the AFE200-...-SL and AFE200-...-SL2 are respectively one and two meters long and have two quick coupling male MDR connectors at the ends.

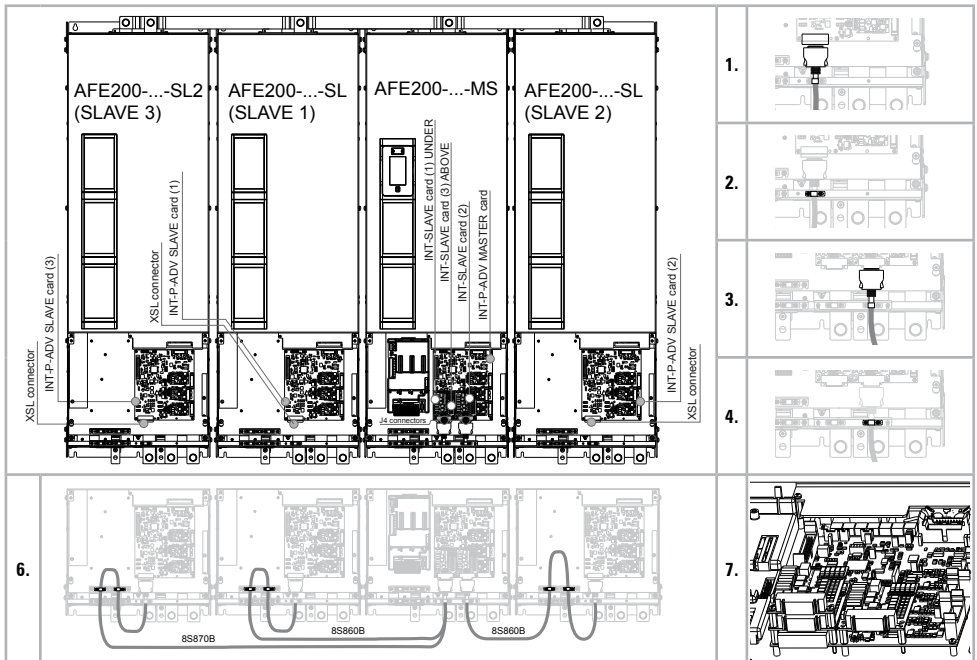

Wiring instructions:

1. Connect one of the 2 ends of the interface cable to the XSL connector of the INT-P-ADV-SLAVE (SLAVE 2) card.
2. Secure the cable using the specific clamp.
3. Connect the other end of the cable to connector J4 of the INT-SLAVE (2) card mounted on the INT-P-ADV-MASTER card of the MASTER AFE.
4. Secure the cable in the relative clamp
5. Repeat steps 1-2-3-4 for SLAVE 1 and SLAVE 3 (see figures 6-7 for INT-SLAVE position on the INT-P-ADV-MASTER and wiring)
6. To prevent the interface cables from coming into contact with the power terminals, fold the excess length of cable inside the SLAVE AFE as shown in the figure and secure it using the specific cable clamps.

A 2.6 MS-SL interface cable wiring size 1.65 MW

Fit the AFE200 MASTER and SLAVE power supplier inside the electrical panel.
Connect all the power section cables and connect the 4 signal cables for interfacing between the 5 AFE200.

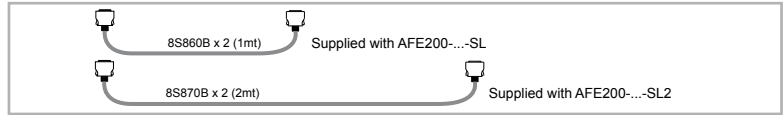

The cables (code 8S860B x 2 + code 8S870B x 2) for connecting the AFE200-...-SL and AFE200-...-SL2 are respectively one and two meters long and have two quick coupling male MDR connectors at the ends.

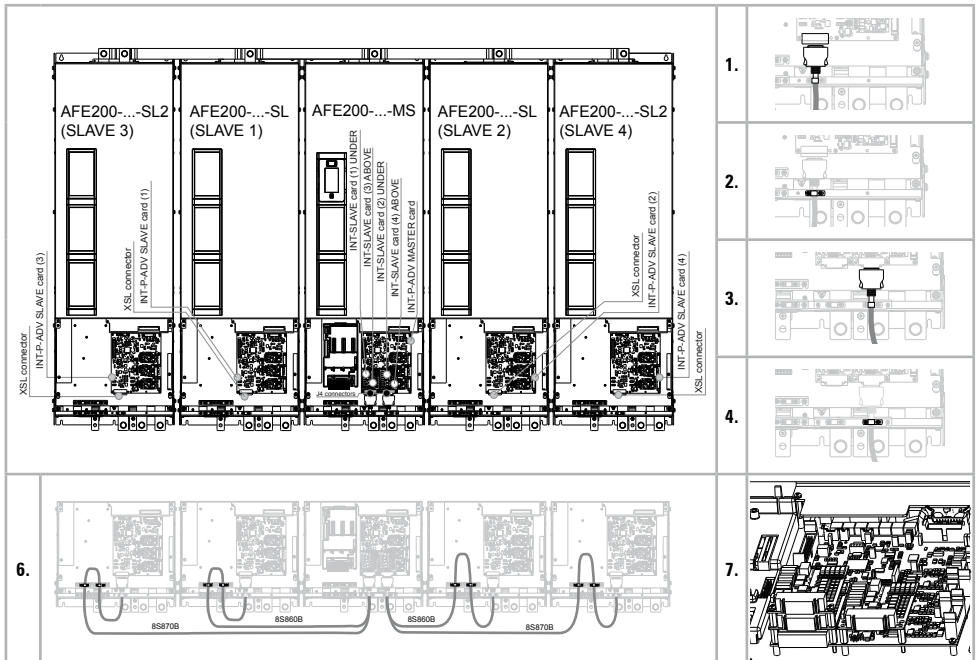

Wiring instructions:

1. Connect one of the 2 ends of the interface cable to the XSL connector of the INT-P-ADV-SLAVE (SLAVE 2) card.
2. Secure the cable using the specific clamp.
3. Connect the other end of the cable to connector J4 of the INT-SLAVE (2) card mounted on the INT-P-ADV-MASTER card of the MASTER AFE.
4. Secure the cable in the relative clamp
5. Repeat steps 1-2-3-4 for SLAVE 1, SLAVE 3 and SLAVE 4 (see figures 6-7 for INT-SLAVE position on the INT-P-ADV-MASTER and wiring)
6. To prevent the interface cables from coming into contact with the power terminals, fold the excess length of cable inside the SLAVE AFE as shown in the figure and secure it using the specific cable clamps.

A 2.7 Jumpers and Switches

INT-P-ADV (MASTER and SLAVE) cards

The jumpers and switches on these cards are factory-set. DO NOT change these settings.

A 2.8 LEDs

The cards incorporate a LED diagnostics system for rapid analysis of everything happening on a multi-unit AFE.

INT-P-ADV (MASTER and SLAVE) cards

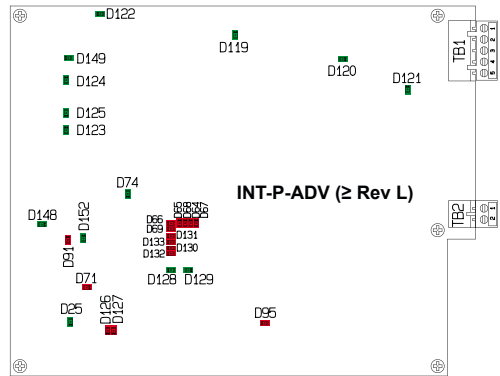
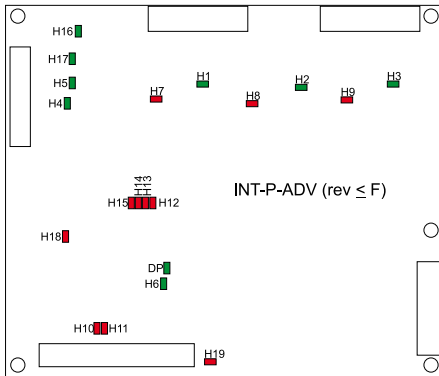

LEDS		Colour	FUNCTION	Normal functioning
≦ F (*)	≥ L (*)			
MONITOR				
H1	D119	Green	+15V_PWR_U monitor	On
H2	D120	Green	+15V_PWR_V monitor	On
H3	D121	Green	+15V_PWR_W monitor	On
H4	D123	Green	+15V monitor	On
H5	D125	Green	-15V monitor	On
H6	D129	Green	+3,3V monitor	On
	D25	Green	+3,3V R monitor	On
H16	D122	Green	+24V monitor	On
H17	D124	Green	+5V monitor	On
DP*	D128	Green	It switches on after power supply start-up when the FPGA configuration sequence is complete	On
ALARM				
H7	D67/D64	Red	PHASE U	Off
H8	D68/D65	Red	PHASE V	Off
H9	D69/D66	Red	PHASE W	Off
H10	D126	Red	It lights up to indicate a power rectifier heat sink overtemperature	Off

LEDS		Colour	FUNCTION	Normal functioning
≤ F (*)	≥ L (*)			
H11	D127	Red	It lights up to indicate overtemperature of the air inside the drive	Off
H15	D131	Red	It lights up in case of overtemperature of one of the IGBT devices. The signal temperature relating to the hotter of the master and slave IGBT devices is sent to the regulation card. A temperature signal is also sent automatically to the regulation card in case of minimum temperature, which could occur in the event of a fault in one of the temperature reading circuits. The loss of one of the temperature signals is indicated by LED H15 (D131), with the code indicated by the number of flashes (*): the sequence of flashes to indicate the faulty PHASE or SLAVE has a 3Hz frequency and is repeated cyclically every 5 seconds.	Off
H18	D91	Red	It lights up on the INT-P-ADV MASTER card to indicate that the drive's total current (master + slave) has exceeded the overcurrent value for the size of drive, whereas it lights up on the INT-P-ADV SLAVE card to indicate that the SLAVE current has only exceeded the overcurrent value of the SLAVE.	Off
	D71	Red	Overvoltage / Undervoltage safety supply	Off
OPERATIONS				
	D148	Red	FPGA active reset HW	On
	D152	Green	Active PWM from regulation and sent to power (master drive or single drive only)	On
	D74	Green	Active PWM to power	On

(*) HW revision of INT-P-ADV card

(*) Led H15 (D131) code indicated by number of flashes	NO. FLASHES
PHASE U	1
PHASE V	2
PHASE W	3
SLAVE 1	4
SLAVE 2	5
SLAVE 3	6
SLAVE 4	7

INT-SLAVE cards

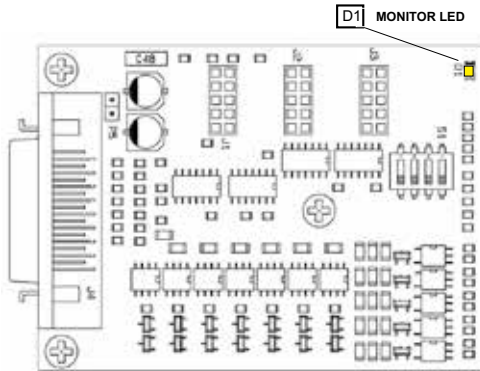

LEDS	Colour	FUNCTION	Normal functioning
MONITOR			
D1	Yellow	It flashes to indicate the presence of the temperature signal of the slave AFE that is connected	Flashes

Appendix 3 - Block Diagrams

System Diagrams Index

DRIVE OVERVIEW [DrvOverview](#)

REFERENCE [Reference](#)

COMMANDS [Commands](#)

DIGITAL INPUTS [DigInps](#)

DIGITAL OUTPUTS [DigOuts](#)

[AnalInps](#) ANALOG INPUTS

[AnalOuts](#) ANALOG OUTPUTS

[CurrCtrl](#) CURRENT CONTROL

[ActCurrConf](#) ACTIVE CURR CONFIG

[Functions](#) FUNCTIONS

Drive overview

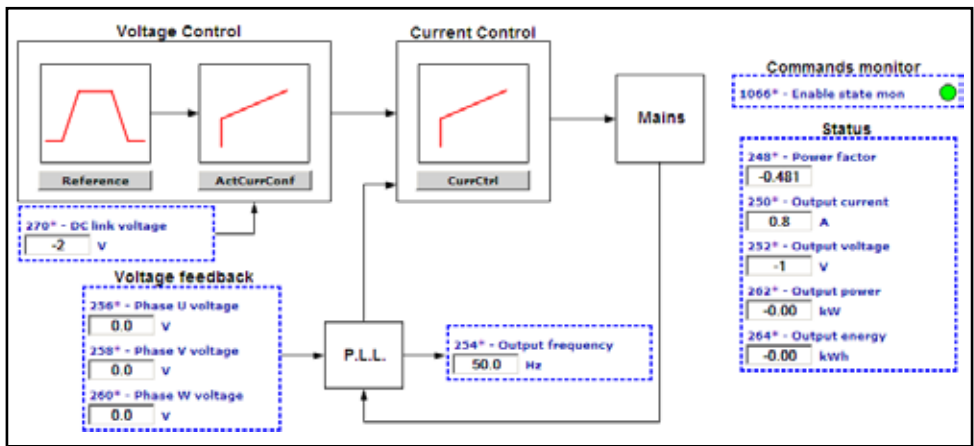

Reference

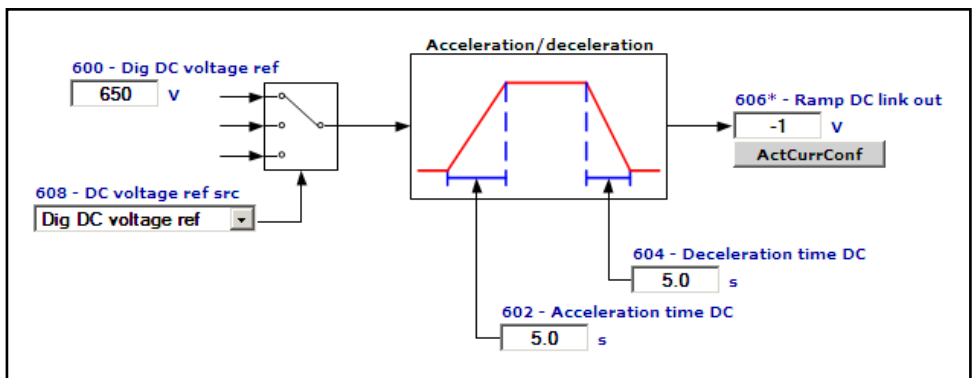

Commands

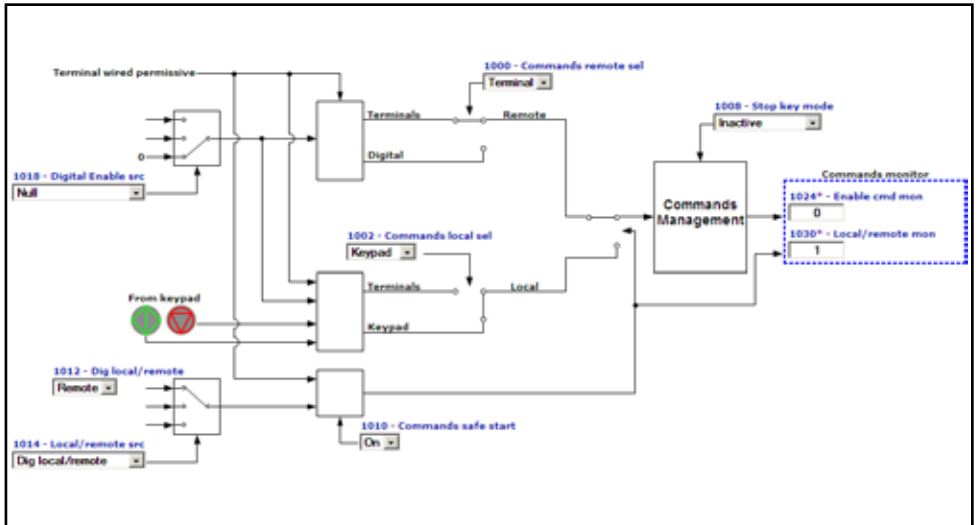

Digital outputs

DIGITAL OUTPUTS STANDARD

DigOutStd

DIGITAL OUTPUTS EXPANSION CARD

DigOutExp

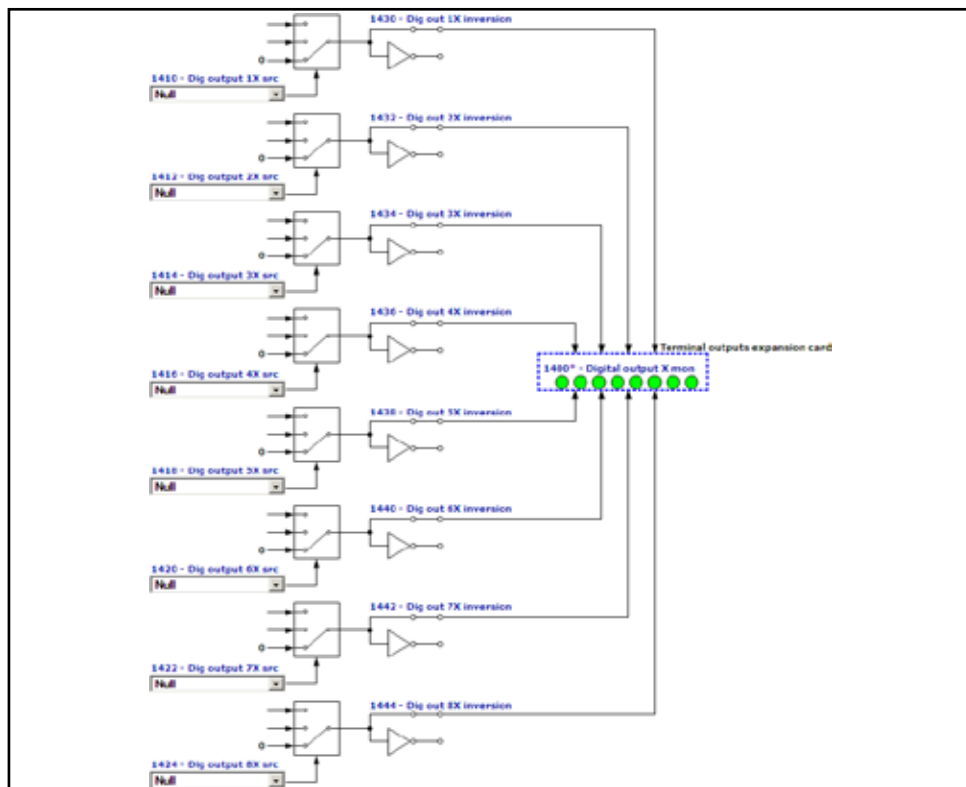
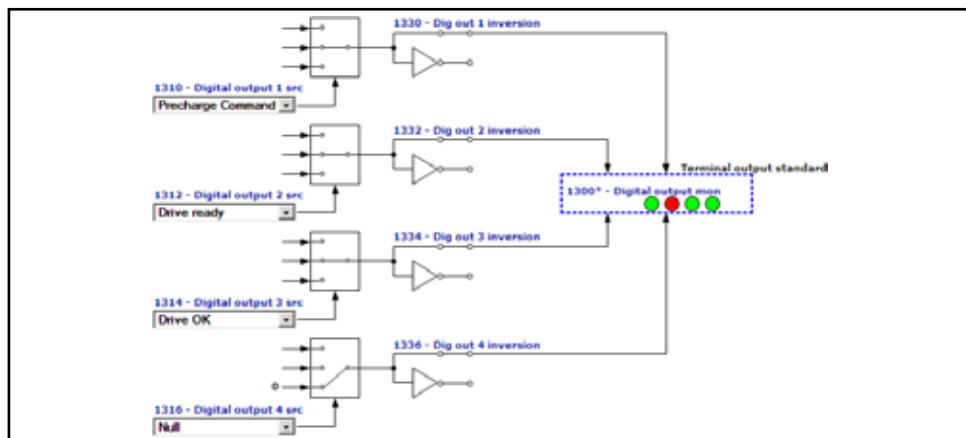

Analog inputs

ANALOG INPUT 1 STANDARD

AnInp1Std

ANALOG INPUT 2 STANDARD

AnInp2Std

ANALOG INPUT 1 EXPANSION CARD

AnInp1Exp

ANALOG INPUT 2 EXPANSION CARD

AnInp2Exp

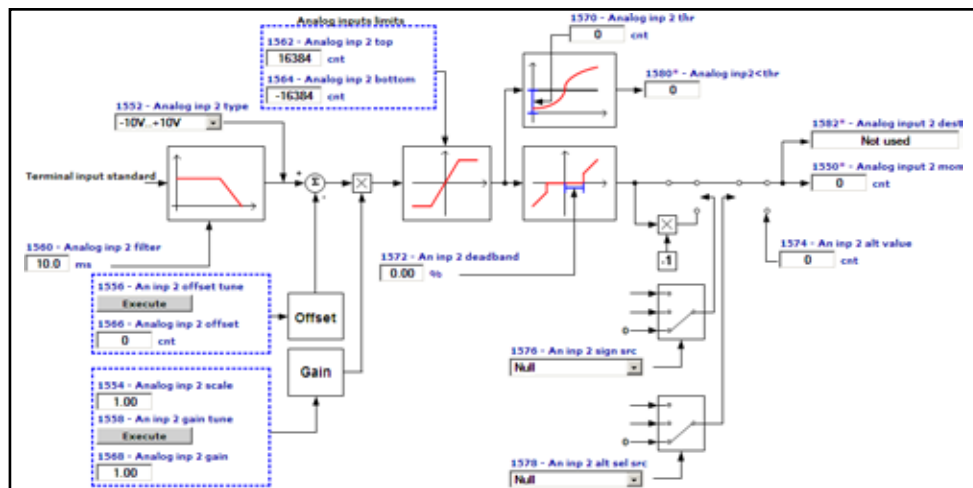
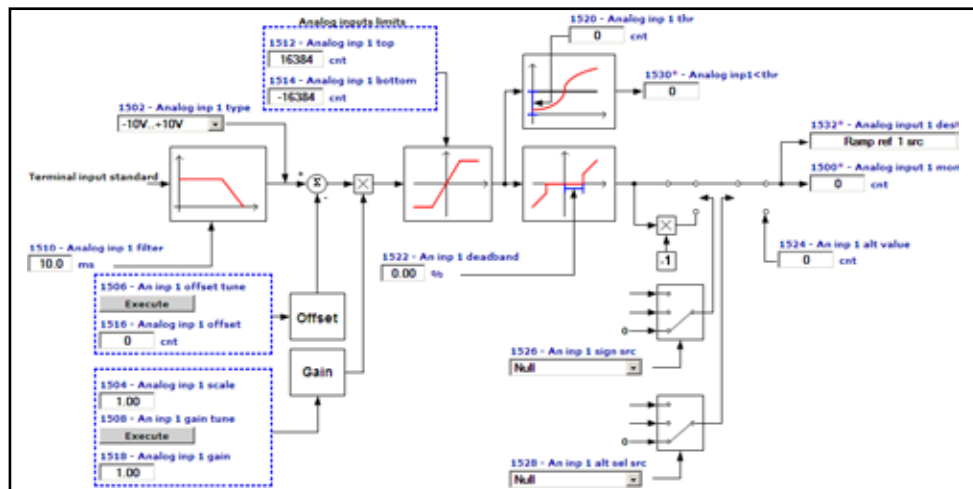

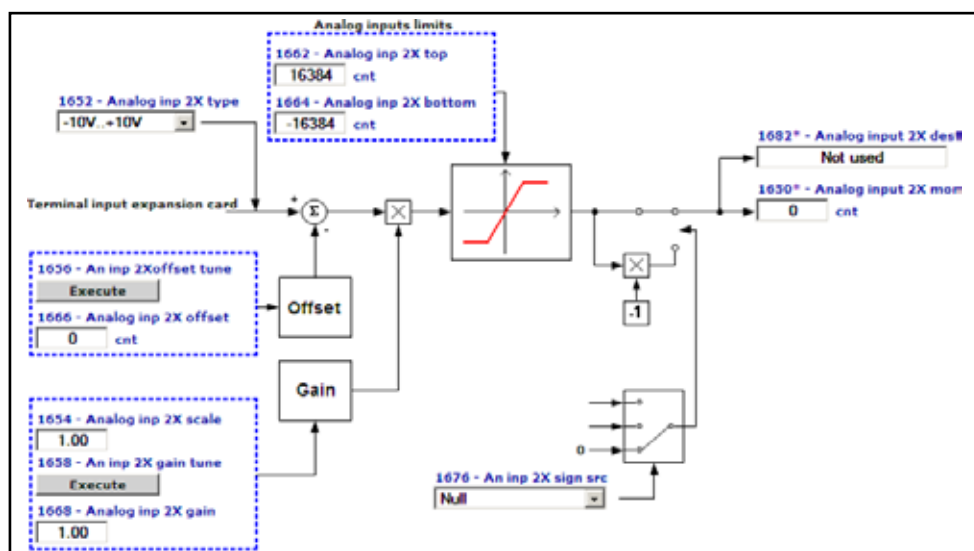
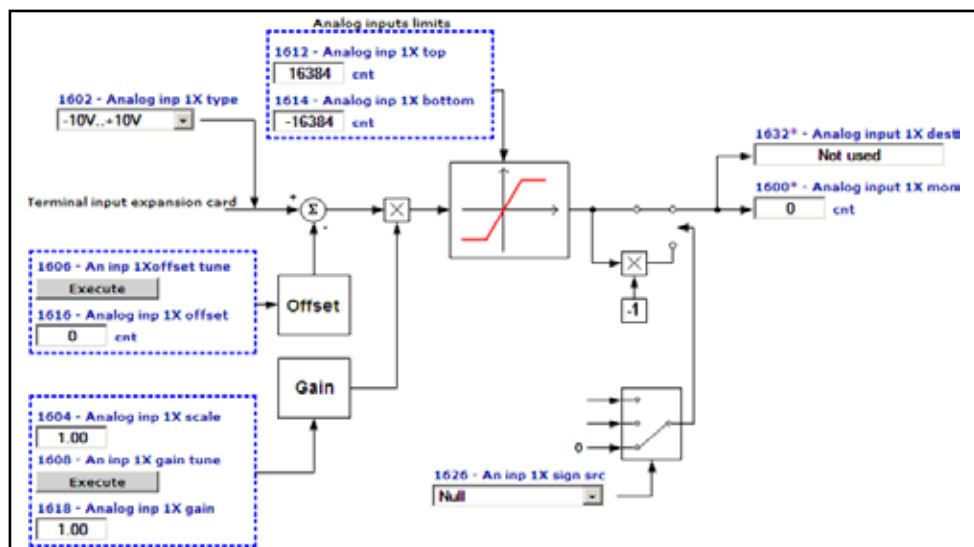

Analog outputs

ANALOG OUTPUT 1 STANDARD AnOut1Std

ANALOG OUTPUT 2 STANDARD AnOut2Std

ANALOG OUTPUT 1 EXPANSION CARD AnOut1Exp

ANALOG OUTPUT 2 EXPANSION CARD AnOut2Exp

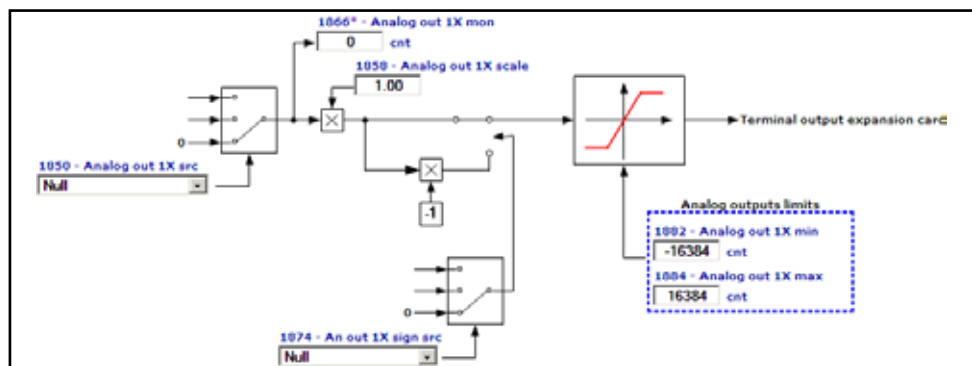
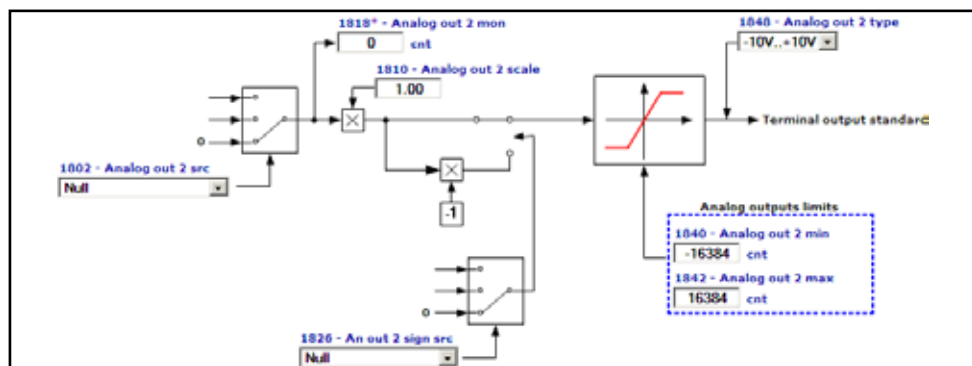
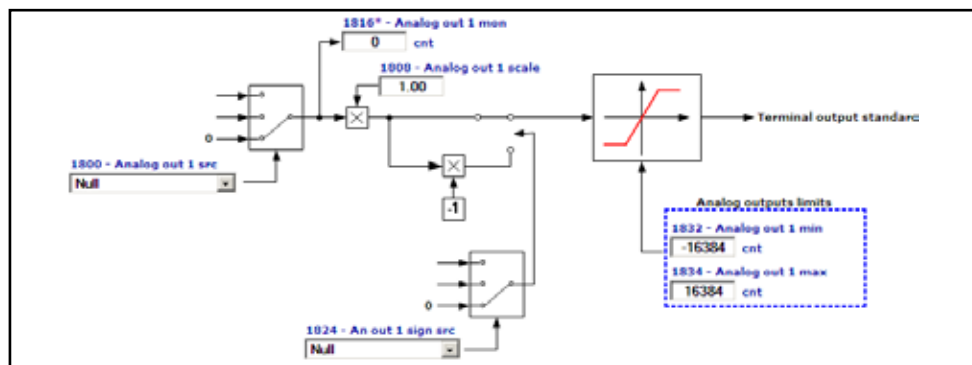

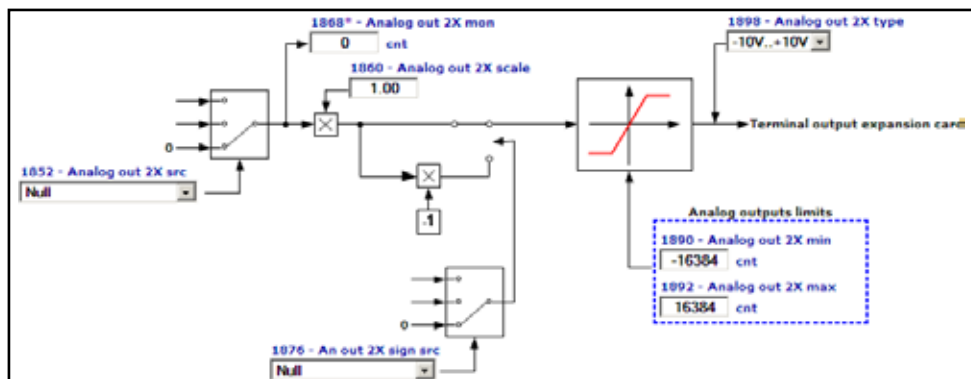

Current Control

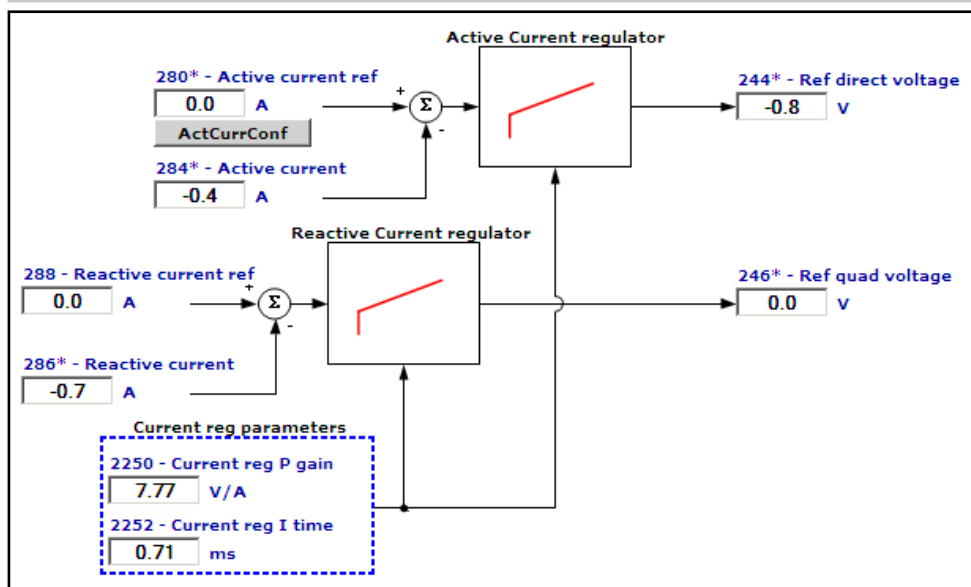

Active Curr Config

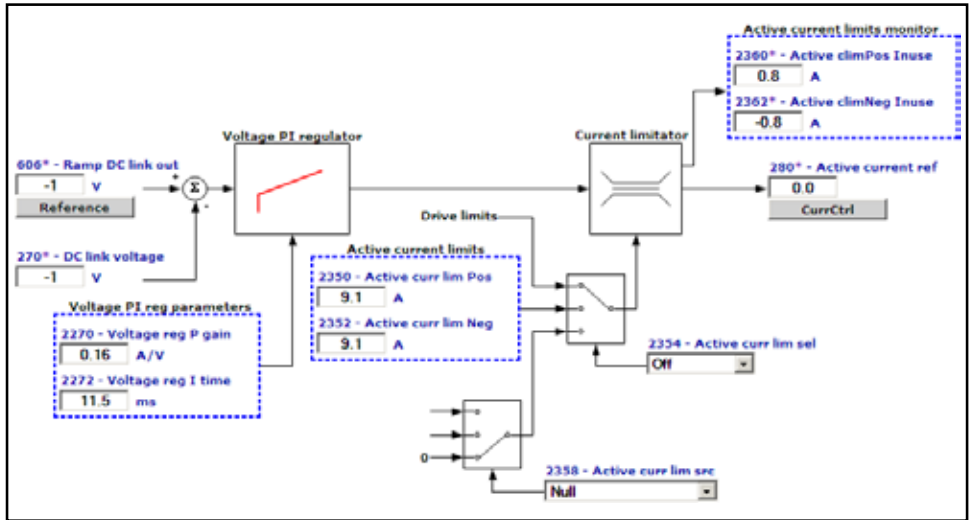

Functions

DOUBLE PAR SET

COMPARE

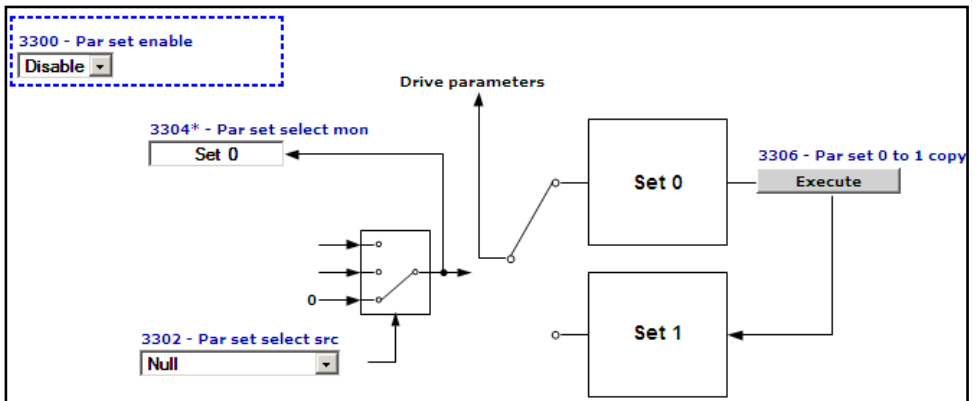
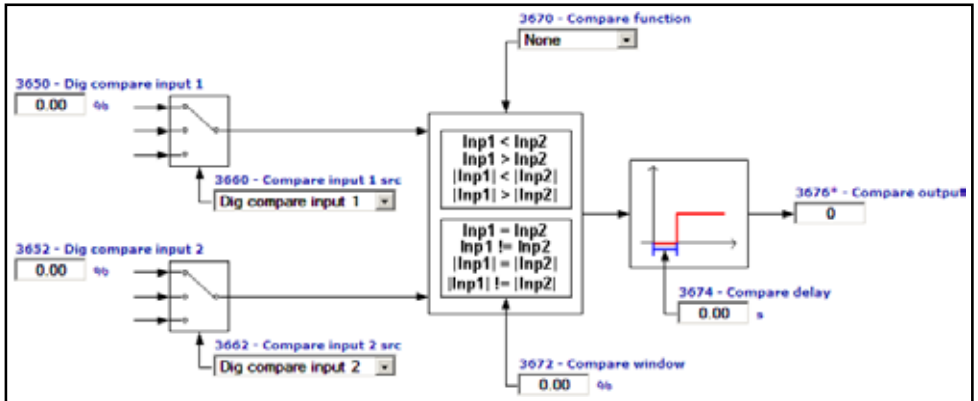

GEFRAN DEUTSCHLAND GMBH

Philipp-Reis-Straße 9a
D-63500 Seligenstadt
Ph. +49 (0) 61828090
Fax +49 (0) 6182809222
vertrieb@gefran.de

SIEI AREG - GERMANY

Gottlieb-Daimler Strasse 17/3
D-74385 - Pleidelsheim
Ph. +49 (0) 7144 897360
Fax +49 (0) 7144 8973697
info@sieiareg.de

SENSORMATE AG

Steigweg 8,
CH-8355 Aadorf, Switzerland
Ph. +41(0)52-2421818
Fax +41(0)52-3661884
<http://www.sensormate.ch>

GEFRAN FRANCE SA

PARC TECHNOLOGIE
Bâtiment K - ZI Champ Dolin
3 Allée des Abruzzes
69800 Saint-Priest
Ph. +33 (0) 478770300
Fax +33 (0) 478770320
commercial@gefran.fr

GEFRAN BENELUX NV

ENA 23 Zone 3, nr. 3910
Lammerdries-Zuid 14A
B-2250 OLEN
Ph. +32 (0) 14248181
Fax +32 (0) 14248180
info@gefran.be

GEFRAN UK LTD

Clarendon Court
Winwick Quay
Warrington
WA2 8QP
Ph. +44 (0) 8452 604555
Fax +44 (0) 8452 604556
sales@gefran.co.uk

**GEFRAN MIDDLE EAST ELEKTRIK VE
ELEKTRONIK SAN. VE TIC. LTD. STI**

Yesilkoy Mah. Ataturk
Cad. No: 12/1 B1 Blok K:12
D: 389 Bakirkoy /Istanbul
TURKIYE
Ph. +90212 465 91 21
Fax +90212 465 91 22

GEFRAN SIEI

Drives Technology Co., Ltd
No. 1285, Beihe Road, Jiading
District, Shanghai, China 201807
Ph. +86 21 69169898
Fax +86 21 69169333
info@gefran.com.cn

GEFRAN SIEI - ASIA

31 Ubi Road 1
#02-07, Aztech Building,
Singapore 408694
Ph. +65 6 8418300
Fax +65 6 7428300
info@gefran.com.sg

GEFRAN INDIA

Survey No. 191/A/1,
Chinchwad Station Road, Chinchwad,
Pune-411033, Maharashtra
Ph. +91 20 6614 6500
Fax +91 20 6614 6501
gefran.india@gefran.in

GEFRAN INC.

8 Lowell Avenue
WINCHESTER - MA 01890
Toll Free 1-888-888-4474
Fax +1 (781) 7291468
info.us@gefran.com

GEFRAN BRASIL

ELETROLETRÔNICA
Avenida Dr. Altino Arantes,
377 Vila Clementino
04042-032 SÃO PAULO - SP
Ph. +55 (0) 1155851133
Fax +55 (0) 1132974012
comercial@gefran.com.br

GEFRAN

GEFRAN S.p.A.

Via Sebina 74
25050 Provatiglion d'Iseo (BS)
ITALY
Ph. +39 030 98881
Fax +39 030 9839063
info@gefran.com
www.gefran.com

Drive & Motion Control Unit

Via Carducci 24
21040 Gerenzano (VA)
ITALY
Ph. +39 02 967601
Fax +39 02 9682653
infomotion@gefran.com

Technical Assistance :

technohelp@gefran.com

Customer Service :

motioncustomer@gefran.com
Ph. +39 02 96760500
Fax +39 02 96760278

Manuale AFEZ00 -EN
0.16 - 7-11-2017

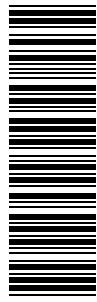

1S9AFEN