

Rexroth IndraDrive MPx-02 to MPx-08 and HMV

R911297319
Edition 08

Troubleshooting Guide



Title Rexroth IndraDrive
 MPx-02 to MPx-08
 and HMV

Type of Documentation Troubleshooting Guide

Document Typecode DOK-INDRV*-GEN-**VRS**-WA08-EN-P

Internal File Reference RS-2dcf592b198e544c0a6846a000d977c5-3-en-US-6

Purpose of Documentation This documentation contains the descriptions of all diagnostic messages implemented in the following firmware versions:

- Drive controller firmware versions MPx-02 to MPx-08 and
- Firmware versions of supply units of type "HMV".

It assists machine operators and installation programmers with troubleshooting.

Record of Revision

Edition	Release Date	Notes
DOK-INDRV*-GEN-**VRS**-WA01-EN-P to DOK-INDRV*-GEN-**VRS**-WA08-EN-P	2004-03-17 to 2012-01-10	See chapter "About This Documentation", marginal note "Editions of This Documentation"

Copyright © Bosch Rexroth AG 2012

This document, as well as the data, specifications and other information set forth in it, are the exclusive property of Bosch Rexroth AG. It may not be reproduced or given to third parties without its consent.

Liability The specified data is intended for product description purposes only and shall not be deemed to be a guaranteed characteristic unless expressly stipulated in the contract. All rights are reserved with respect to the content of this documentation and the availability of the product.

Published by Bosch Rexroth AG
 Bgm.-Dr.-Nebel-Str. 2 ■ 97816 Lohr a. Main, Germany
 Telephone +49 (0)93 52/ 40-0 ■ Fax +49 (0)93 52/ 40-48 85
<http://www.boschrexroth.com/>
 Dept. DC-IA/EDY1 (SA, BB)

Note This document has been printed on chlorine-free bleached paper.

Table of Contents

	Page
1 Introduction.....	23
1.1 About This Documentation.....	23
1.2 Reference Documentations.....	24
1.2.1 Drive Systems, System Components.....	24
1.2.2 Motors.....	24
1.2.3 Cables.....	25
1.2.4 Firmware.....	25
2 Important Directions for Use	27
2.1 Appropriate Use	27
2.1.1 Introduction.....	27
2.1.2 Areas of Use and Application.....	27
2.2 Inappropriate Use.....	28
3 Safety Instructions for Electric Drives and Controls.....	29
3.1 Definitions of Terms.....	29
3.2 General Information.....	30
3.2.1 Using the Safety Instructions and Passing Them on to Others.....	30
3.2.2 Requirements for Safe Use.....	30
3.2.3 Hazards by Improper Use.....	31
3.3 Instructions with Regard to Specific Dangers.....	33
3.3.1 Protection Against Contact With Electrical Parts and Housings.....	33
3.3.2 Protective Extra-Low Voltage as Protection Against Electric Shock	34
3.3.3 Protection Against Dangerous Movements.....	35
3.3.4 Protection Against Magnetic and Electromagnetic Fields During Operation and Mounting.....	36
3.3.5 Protection Against Contact With Hot Parts.....	36
3.3.6 Protection During Handling and Mounting.....	37
3.3.7 Battery Safety.....	37
3.3.8 Protection Against Pressurized Systems.....	38
3.4 Explanation of Signal Words and the Safety Alert Symbol.....	38
4 Basics on Device Diagnosis.....	41
4.1 Diagnostic System.....	41
4.1.1 Coded Diagnostic Messages of the Drive.....	41
Brief Description.....	41
Drive-Internal Generation of Diagnostic Messages.....	41
Structure of a Diagnostic Message.....	42
Language Selection.....	44
4.2 Status Classes, Status Displays, Control Parameters.....	44
4.2.1 General Information.....	44
4.2.2 Status Classes.....	44
Brief Description.....	44
Functional Description.....	45

Table of Contents

	Page
Notes on Commissioning.....	46
4.2.3 Fixed Status Displays.....	47
Function-Related Status Parameters.....	47
Status Parameters for Real-Time Status Bits.....	48
4.2.4 Control Parameters.....	49
4.3 Control Panels of the IndraDrive Controllers.....	49
4.3.1 General Information on the Operation Options	49
Control Panel Variants.....	49
4.4 Control Panel.....	50
4.4.1 Brief Description.....	50
4.4.2 Functional Description.....	51
4.5 Terms, Basic Principles.....	69
4.5.1 Parameters.....	69
4.5.2 Data Storage and Parameter Handling.....	69
4.5.3 Password.....	70
4.5.4 Commands.....	71
4.5.5 Operation Modes.....	71
4.5.6 Warnings.....	72
4.5.7 Errors.....	72
5 Operating States.....	75
5.1 General Information.....	75
5.2 Ab / VM Bb.....	75
5.3 AC.....	75
5.4 AE.....	75
5.5 AF.....	75
5.6 AH.....	75
5.7 AR.....	75
5.8 AS.....	75
5.9 ASP.....	75
5.10 AU.....	75
5.11 bb / VM bb.....	75
5.12 charg / VM charg.....	76
5.13 CM.....	76
5.14 OM.....	76
5.15 P0 / VM P0.....	76
5.16 P-1.....	76
5.17 P1 / VM P1.....	76
5.18 P2 / VM P2.....	76
5.19 P3 / VM P3.....	76
5.20 PM.....	76
5.21 PL.....	76
5.22 RL.....	76
5.23 SBB.....	76
5.24 SBB1.....	77
5.25 SBB2.....	77

Table of Contents

	Page
5.26 SBB3.....	77
5.27 SBB4.....	77
5.28 SBH.....	77
5.29 SH.....	77
5.30 SMM1.....	77
5.31 SMM2.....	77
5.32 SMM3.....	77
5.33 SMM4.....	77
5.34 SS1.....	77
5.35 SS1 ES.....	77
5.36 SS2.....	77
5.37 STO.....	77
5.38 VM Lb.....	78
5.39 VM LB.....	78
5.40 VM ZKS.....	78
6 Diagnostic Messages when Booting the Devices.....	79
6.1 Devices With Valid Firmware.....	79
6.2 Devices Without Valid Firmware.....	79
6.3 Error Messages When Booting the Devices.....	79
6.3.1 PLC ?	79
6.3.2 Stop PLC	80
6.3.3 Run PLC	80
6.3.4 Load New Safety ?.....	80
6.3.5 No IDN on MMC !.....	80
6.3.6 Load Par from MMC.....	81
6.3.7 End C29	81
6.3.8 new MMC activate.....	81
6.3.9 MMC not correct!.....	81
6.3.10 IBF not correct!.....	82
6.3.11 Firmware update ?.....	82
6.3.12 Update Error !.....	82
6.3.13 XXX Upd	82
6.3.14 ActLW Up	83
6.3.15 E FIP nf	83
6.3.16 E FIP CS	83
6.3.17 E Pge Sz	83
6.3.18 E MMC op	84
6.3.19 E MMC cl	84
6.3.20 E Adress	84
6.3.21 E Length	84
6.3.22 E ET SW	85
6.3.23 E MMC cp	85
6.3.24 E HW nok	85
6.3.25 E SW-VER	86

Table of Contents

	Page
7 Diagnostic Status Messages	87
7.1 A0000 Communication phase 0	87
7.2 A0001 Communication phase 1	87
7.3 A0002 Communication phase 2	88
7.4 A0003 Communication phase 3	89
7.5 A0009 Automatic baud rate detection for SERCOS interface	89
7.6 A0010 Drive HALT	90
7.7 A0011 Safe torque off active	90
7.8 A0012 Control and power sections ready for operation	91
7.9 A0013 Ready for power on	91
7.10 A0014 Safe stop 1 (Emergency stop) active	92
7.11 A0015 Safe stop 1 active	93
7.12 A0016 Safe stop 2 active	93
7.13 A0017 Special mode motion active	94
7.14 A0018 Special mode safe motion 1 active	95
7.15 A0019 Special mode safe motion 2 active	96
7.16 A0020 Special mode safe motion 3 active	97
7.17 A0021 Special mode safe motion 4 active	99
7.18 A0050 Parameterization level 1 active	100
7.19 A0051 Operating mode	100
7.20 A0100 Torque control	100
7.21 A0101 Velocity control	101
7.22 A0102 Position mode, encoder 1	101
7.23 A0103 Position mode, encoder 2	101
7.24 A0104 Position mode lagless, encoder 1	102
7.25 A0105 Position mode lagless, encoder 2	102
7.26 A0106 Drive-internal interpolation, encoder 1	103
7.27 A0107 Drive-internal interpolation, encoder 2	103
7.28 A0108 Drive controlled interpolation, lagless, encoder 1	103
7.29 A0109 Drive controlled interpolation, lagless, encoder 2	104
7.30 A0110 Velocity synchronization, virtual master axis	104
7.31 A0111 Velocity synchronization, real master axis	105
7.32 A0112 Phase synchronization, encoder 1, virtual master axis	105
7.33 A0113 Phase synchronization, encoder 2, virtual master axis	105
7.34 A0114 Phase synchronization, encoder 1, real master axis	106
7.35 A0115 Phase synchronization, encoder 2, real master axis	106
7.36 A0116 Phase synchr. lagless, encoder 1, virtual master axis	107
7.37 A0117 Phase synchr. lagless, encoder 2, virtual master axis	107
7.38 A0118 Phase synchr. lagless, encoder 1, real master axis	107
7.39 A0119 Phase synchr. lagless, encoder 2, real master axis	108
7.40 A0128 Cam, encoder 1, virtual master axis	108
7.41 A0129 Cam, encoder 2, virtual master axis	109
7.42 A0130 Cam, encoder 1, real master axis	109
7.43 A0131 Cam, encoder 2, real master axis	109
7.44 A0132 Cam, lagless, encoder 1, virt. master axis	110
7.45 A0133 Cam, lagless, encoder 2, virt. master axis	110

Table of Contents

	Page
7.46 A0134 Cam, lagless, encoder 1, real master axis.....	111
7.47 A0135 Cam, lagless, encoder 2, real master axis.....	111
7.48 A0136 MotionProfile, encoder 1, virtual master axis.....	112
7.49 A0137 MotionProfile, encoder 2, virtual master axis.....	112
7.50 A0138 MotionProfile, encoder 2, real master axis.....	113
7.51 A0139 MotionProfile, encoder 1, real master axis.....	113
7.52 A0140 MotionProfile lagless, encoder 1, virtual master axis.....	114
7.53 A0141 MotionProfile lagless, encoder 2, virtual master axis.....	114
7.54 A0142 MotionProfile lagless, encoder 1, real master axis.....	115
7.55 A0143 MotionProfile lagless, encoder 2, real master axis.....	115
7.56 A0150 Drive-controlled positioning, encoder 1.....	116
7.57 A0151 Drive-controlled positioning, encoder 1, lagless.....	116
7.58 A0152 Drive-controlled positioning, encoder 2.....	117
7.59 A0153 Drive-controlled positioning, encoder 2, lagless.....	117
7.60 A0154 Position mode drive controlled, encoder 1.....	118
7.61 A0155 Position mode drive controlled, encoder 2.....	118
7.62 A0156 Position mode lagless, encoder 1 drive controlled.....	119
7.63 A0157 Position mode lagless, encoder 2 drive controlled.....	119
7.64 A0160 Position mode drive controlled.....	120
7.65 A0161 Drive-controlled positioning.....	120
7.66 A0162 Positioning block mode.....	121
7.67 A0163 Position synchronization.....	121
7.68 A0164 Velocity synchronization.....	122
7.69 A0206 Positioning block mode, encoder 1.....	122
7.70 A0207 Positioning block mode lagless, encoder 1.....	122
7.71 A0210 Positioning block mode, encoder 2.....	123
7.72 A0211 Positioning block mode lagless, encoder 2.....	123
7.73 A0403 Quick stop with probe detection is active.....	123
7.74 A0500 Supply module in voltage control.....	124
7.75 A0502 Supply module in operation.....	124
7.76 A0503 DC bus charging active.....	124
7.77 A0520 DC bus quick discharge active.....	125
7.78 A0800 Unknown operating mode.....	125
7.79 A4000 Automatic drive check and adjustment.....	126
7.80 A4001 Drive deceleration to standstill.....	126
7.81 A4002 Drive in automatic mode.....	127
7.82 A4003 Setting-up mode is active.....	127
8 Error Messages.....	129
8.1 Fatal System Errors (F9xxx and E-0000).....	129
8.1.1 Behavior in the Case of Fatal System Errors.....	129
8.1.2 E0000 E-0000 Processor exception error.....	129
8.1.3 F9001 Error internal function call.....	130
8.1.4 F9002 Error internal RTOS function call.....	131
8.1.5 F9003 Watchdog.....	131
8.1.6 F9004 Hardware trap.....	131

Table of Contents

	Page
8.2	Fatal Errors (F8xxx)..... 131
8.2.1	Behavior in Case of Fatal Errors (F8xxx)..... 131
8.2.2	F8000 Fatal hardware error..... 132
8.2.3	F8010 Autom. commutation: Max. motion range when moving back..... 133
8.2.4	F8011 Commutation offset could not be determined..... 134
8.2.5	F8012 Autom. commutation: Max. motion range..... 135
8.2.6	F8013 Automatic commutation: Current too low..... 135
8.2.7	F8014 Automatic commutation: Overcurrent..... 136
8.2.8	F8015 Automatic commutation: Timeout..... 137
8.2.9	F8016 Automatic commutation: Iteration without result..... 137
8.2.10	F8017 Automatic commutation: Incorrect commutation adjustment..... 138
8.2.11	F8018 Device overtemperature shutdown..... 139
8.2.12	F8022 Enc. 1: Enc. signals incorr. (can be cleared in ph. 2)..... 140
8.2.13	F8023 Error mechanical link of encoder or motor connection..... 141
8.2.14	F8025 Overvoltage in power section..... 141
8.2.15	F8027 Safe torque off while drive enabled..... 142
8.2.16	F8028 Overcurrent in power section..... 143
8.2.17	F8030 Safe stop 1 while drive enabled..... 143
8.2.18	F8042 Encoder 2 error: Signal amplitude incorrect..... 144
8.2.19	F8057 Device overload shutdown..... 145
8.2.20	F8060 Overcurrent in power section..... 145
8.2.21	F8064 Interruption of motor phase..... 146
8.2.22	F8067 Synchronization PWM-Timer wrong..... 147
8.2.23	F8069 +/-15Volt DC error..... 147
8.2.24	F8070 +24Volt DC error..... 148
8.2.25	F8076 Error in error angle loop..... 148
8.2.26	F8078 Speed loop error..... 149
8.2.27	F8079 Velocity limit value exceeded..... 150
8.2.28	F8091 Power section defective..... 150
8.2.29	F8100 Error when initializing the parameter handling..... 151
8.2.30	F8102 Error when initializing power section..... 152
8.2.31	F8118 Invalid power section/firmware combination..... 152
8.2.32	F8120 Invalid control section/firmware combination..... 153
8.2.33	F8122 Control section defective..... 153
8.2.34	F8129 Incorrect optional module firmware..... 153
8.2.35	F8130 Firmware of option 2 of safety technology defective..... 154
8.2.36	F8133 Error when checking interrupting circuits..... 154
8.2.37	F8134 SBS: Fatal error..... 155
8.2.38	F8135 SMD: Velocity exceeded..... 156
8.2.39	F8140 Fatal CCD error..... 156
8.2.40	F8201 Safety technology basic initialization incorrect..... 156
8.2.41	F8203 Safety technology configuration parameter invalid..... 157
8.2.42	F8813 Connection error mains choke..... 158
8.2.43	F8830 Power section error..... 159
8.2.44	F8838 Overcurrent external braking resistor..... 159
8.3	Safety Technology Errors (F7xxx)..... 160

Table of Contents

	Page
8.3.1	Behavior in Case of Safety Technology Errors..... 160
8.3.2	F7010 Safely-limited increment exceeded..... 161
8.3.3	F7011 Safely-monitored position, exceeded in pos. direction..... 162
8.3.4	F7012 Safely-monitored position, exceeded in neg. direction..... 162
8.3.5	F7013 Safely-limited speed exceeded..... 163
8.3.6	F7014 Timeout safely-monitored transient oscillation..... 163
8.3.7	F7020 Safe maximum speed exceeded..... 164
8.3.8	F7021 Safely-limited position exceeded..... 165
8.3.9	F7030 Position window Safe stop 2 exceeded..... 165
8.3.10	F7031 Incorrect direction of motion..... 166
8.3.11	F7040 Validation error parameterized - effective threshold..... 166
8.3.12	F7041 Actual position value validation error..... 167
8.3.13	F7042 Validation error of safe operation mode..... 168
8.3.14	F7043 Error of output stage interlock..... 168
8.3.15	F7050 Time for stopping process exceeded..... 169
8.3.16	F7051 Safely-monitored deceleration exceeded..... 169
8.4	Errors of Category F6xxx..... 170
8.4.1	Behavior in Case of Errors of Category F6xxx..... 170
8.4.2	F6006 Incorrect initialization of effective master axis position..... 171
8.4.3	F6010 PLC runtime error..... 172
8.4.4	F6024 Maximum braking time exceeded..... 173
8.4.5	F6028 Position limit value exceeded (overflow)..... 174
8.4.6	F6029 Positive position limit exceeded..... 175
8.4.7	F6030 Negative position limit exceeded..... 176
8.4.8	F6034 Emergency-Stop activated..... 176
8.4.9	F6042 Both travel range limit switches activated..... 177
8.4.10	F6043 Positive travel range limit switch activated..... 178
8.4.11	F6044 Negative travel range limit switch activated..... 179
8.4.12	F6140 CCD slave error (emergency halt)..... 179
8.5	Interface Errors (F4xxx)..... 180
8.5.1	Behavior in Case of Interface Errors 180
8.5.2	F4001 Sync telegram failure..... 180
8.5.3	F4002 RTD telegram failure..... 181
8.5.4	F4003 Invalid communication phase shutdown..... 183
8.5.5	F4004 Error during phase progression..... 183
8.5.6	F4005 Error during phase regression..... 183
8.5.7	F4006 Phase switching without ready signal..... 184
8.5.8	F4009 Bus failure..... 184
8.5.9	F4011 Communication watchdog: Overload of cyclic communication..... 186
8.5.10	F4012 Incorrect I/O length..... 187
8.5.11	F4016 PLC double real-time channel failure..... 187
8.5.12	F4017 S-III: Incorrect sequence during phase switch..... 188
8.5.13	F4034 Emergency-Stop activated..... 188
8.5.14	F4140 CCD communication error..... 189
8.6	Non-Fatal Safety Technology Errors (F3xxx)..... 190
8.6.1	Behavior in Case of Non-Fatal Safety Technology Errors..... 190

Table of Contents

	Page
8.6.2	F3111 Refer. missing when selecting safety related end pos..... 190
8.6.3	F3112 Safe reference missing..... 191
8.6.4	F3115 Brake check time interval exceeded..... 193
8.6.5	F3116 Nominal load torque of holding system exceeded..... 194
8.6.6	F3117 Actual position values validation error..... 195
8.6.7	F3122 SBS: System error..... 196
8.6.8	F3123 SBS: Brake check missing..... 196
8.6.9	F3130 Error when checking input signals..... 197
8.6.10	F3131 Error when checking acknowledgment signal..... 198
8.6.11	F3132 Error when checking diagnostic output signal..... 199
8.6.12	F3133 Error when checking interrupting circuits..... 200
8.6.13	F3134 Dynamization time interval incorrect..... 201
8.6.14	F3135 Dynamization pulse width incorrect..... 203
8.6.15	F3140 Safety parameters validation error..... 205
8.6.16	F3141 Selection validation error..... 206
8.6.17	F3142 Activation time of enabling control exceeded..... 206
8.6.18	F3143 Safety command for clearing errors incorrect..... 208
8.6.19	F3144 Incorrect safety configuration..... 209
8.6.20	F3145 Error when unlocking the safety door..... 210
8.6.21	F3146 System error channel 2..... 211
8.6.22	F3147 System error channel 1..... 212
8.6.23	F3150 Safety command for system start incorrect..... 213
8.6.24	F3151 Safety command for system halt incorrect..... 214
8.6.25	F3152 Incorrect backup of safety technology data..... 214
8.6.26	F3160 Communication error of safe communication..... 215
8.7	Non-Fatal Errors (F2xxx)..... 216
8.7.1	Behavior in the Case of Non-Fatal Errors..... 216
8.7.2	F2002 Assignment of encoder for synchronization is not allowed..... 216
8.7.3	F2003 Motion step skipped..... 217
8.7.4	F2004 Error in MotionProfile..... 218
8.7.5	F2005 Cam table invalid..... 219
8.7.6	F2006 MMC was removed..... 220
8.7.7	F2007 Switching to non-initialized operation mode..... 220
8.7.8	F2008 RL The motor type has changed..... 221
8.7.9	F2009 PL Load parameter default values..... 222
8.7.10	F2010 Error when initializing digital I/O (-> S-0-0423)..... 223
8.7.11	F2011 PLC - Error no. 1..... 224
8.7.12	F2012 PLC - Error no. 2..... 225
8.7.13	F2013 PLC - Error no. 3..... 225
8.7.14	F2014 PLC - Error no. 4..... 225
8.7.15	F2015 PLC - Error no. 5..... 226
8.7.16	F2016 PLC - Error no. 6..... 226
8.7.17	F2017 PLC - Error no. 7..... 227
8.7.18	F2018 Device overtemperature shutdown..... 227
8.7.19	F2019 Motor overtemperature shutdown..... 228
8.7.20	F2021 Motor temperature monitor defective..... 229

Table of Contents

	Page
8.7.21 F2022 Device temperature monitor defective.....	230
8.7.22 F2025 Drive not ready for control.....	230
8.7.23 F2026 Undervoltage in power section.....	231
8.7.24 F2027 Excessive oscillation in DC bus.....	231
8.7.25 F2028 Excessive deviation.....	232
8.7.26 F2031 Encoder 1 error: Signal amplitude incorrect.....	232
8.7.27 F2032 Validation error during commutation fine adjustment.....	233
8.7.28 F2033 External power supply X10 error.....	234
8.7.29 F2036 Excessive position feedback difference.....	234
8.7.30 F2037 Excessive position command difference.....	235
8.7.31 F2039 Maximum acceleration exceeded.....	236
8.7.32 F2040 Device overtemperature 2 shutdown.....	236
8.7.33 F2042 Encoder 2: Encoder signals incorrect.....	237
8.7.34 F2043 Measuring encoder: Encoder signals incorrect.....	238
8.7.35 F2044 External power supply X15 error.....	239
8.7.36 F2048 Low battery voltage.....	239
8.7.37 F2050 Overflow of target position preset memory.....	240
8.7.38 F2051 No sequential block in target position preset memory.....	241
8.7.39 F2053 Incr. encoder emulator: Pulse frequency too high.....	241
8.7.40 F2054 Incr. encoder emulator: Hardware error.....	242
8.7.41 F2055 External power supply dig. I/O error.....	243
8.7.42 F2057 Target position out of travel range.....	243
8.7.43 F2058 Internal overflow by positioning input.....	244
8.7.44 F2059 Incorrect command value direction when positioning.....	245
8.7.45 F2063 Internal overflow master axis generator.....	246
8.7.46 F2064 Incorrect cmd value direction master axis generator.....	246
8.7.47 F2067 Synchronization to master communication incorrect.....	247
8.7.48 F2068 Brake error.....	247
8.7.49 F2069 Error when releasing the motor holding brake.....	248
8.7.50 F2074 Actual pos. value 1 outside absolute encoder window.....	249
8.7.51 F2075 Actual pos. value 2 outside absolute encoder window.....	249
8.7.52 F2076 Actual pos. value 3 outside absolute encoder window.....	250
8.7.53 F2077 Current measurement trim wrong.....	251
8.7.54 F2086 Error supply module.....	252
8.7.55 F2087 Module group communication error.....	252
8.7.56 F2100 Incorrect access to command value memory.....	253
8.7.57 F2101 It was impossible to address MMC.....	253
8.7.58 F2102 It was impossible to address I2C memory.....	254
8.7.59 F2103 It was impossible to address EnDat memory.....	254
8.7.60 F2104 Commutation offset invalid.....	255
8.7.61 F2105 It was impossible to address Hiperface memory.....	255
8.7.62 F2110 Error in non-cyclical data communic. of power section.....	256
8.7.63 F2120 MMC: Defective or missing, replace.....	256
8.7.64 F2121 MMC: Incorrect data or file, create correctly.....	257
8.7.65 F2122 MMC: Incorrect IBF file, correct it.....	257
8.7.66 F2123 Retain data backup impossible.....	258

Table of Contents

	Page
8.7.67	F2124 MMC: Saving too slowly, replace..... 259
8.7.68	F2130 Error comfort control panel..... 259
8.7.69	F2140 CCD slave error..... 260
8.7.70	F2150 MLD motion function block error..... 260
8.7.71	F2174 Loss of motor encoder reference..... 261
8.7.72	F2175 Loss of optional encoder reference..... 261
8.7.73	F2176 Loss of measuring encoder reference..... 262
8.7.74	F2177 Modulo limitation error of motor encoder..... 263
8.7.75	F2178 Modulo limitation error of optional encoder..... 263
8.7.76	F2179 Modulo limitation error of measuring encoder..... 264
8.7.77	F2190 Incorrect Ethernet configuration..... 264
8.7.78	F2260 Command current limit shutoff..... 265
8.7.79	F2270 Analog input 1 or 2, wire break..... 266
8.7.80	F2802 PLL is not synchronized..... 267
8.7.81	F2814 Undervoltage in mains..... 267
8.7.82	F2815 Overvoltage in mains..... 267
8.7.83	F2816 Softstart fault power supply unit..... 268
8.7.84	F2817 Overvoltage in power section..... 268
8.7.85	F2818 Phase failure..... 269
8.7.86	F2819 Mains failure..... 270
8.7.87	F2820 Braking resistor overload..... 270
8.7.88	F2821 Error in control of braking resistor..... 271
8.7.89	F2825 Switch-on threshold braking resistor too low..... 272
8.7.90	F2833 Ground fault in motor line..... 272
8.7.91	F2834 Contactor control error..... 273
8.7.92	F2835 Mains contactor wiring error..... 273
8.7.93	F2836 DC bus balancing monitor error..... 274
8.7.94	F2837 Contactor monitoring error..... 274
8.7.95	F2840 Error supply shutdown..... 274
8.7.96	F2860 Overcurrent in mains-side power section..... 275
8.7.97	F2890 Invalid device code..... 276
8.7.98	F2891 Incorrect interrupt timing..... 276
8.7.99	F2892 Hardware variant not supported..... 276
8.8	SERCOS Service Channel Error Codes / Error Messages of Serial Communication..... 276
9	Warnings (Exxxx)..... 279
9.1	Fatal Warnings (E8xxx)..... 279
9.1.1	Behavior in the Case of Fatal Warnings..... 279
9.1.2	E8025 Overvoltage in power section..... 279
9.1.3	E8026 Undervoltage in power section..... 280
9.1.4	E8027 Safe torque off while drive enabled..... 281
9.1.5	E8028 Overcurrent in power section..... 281
9.1.6	E8029 Positive position limit exceeded..... 282
9.1.7	E8030 Negative position limit exceeded..... 283
9.1.8	E8034 Emergency-Stop activated..... 284
9.1.9	E8040 Torque/force actual value limit active..... 284

Table of Contents

	Page
9.1.10	E8041 Current limit active..... 285
9.1.11	E8042 Both travel range limit switches activated..... 285
9.1.12	E8043 Positive travel range limit switch activated..... 286
9.1.13	E8044 Negative travel range limit switch activated..... 287
9.1.14	E8055 Motor overload, current limit active..... 287
9.1.15	E8057 Device overload, current limit active..... 288
9.1.16	E8058 Drive system not ready for operation..... 289
9.1.17	E8260 Torque/force command value limit active..... 289
9.1.18	E8802 PLL is not synchronized..... 290
9.1.19	E8814 Undervoltage in mains..... 291
9.1.20	E8815 Overvoltage in mains..... 292
9.1.21	E8818 Phase failure..... 292
9.1.22	E8819 Mains failure..... 293
9.2	Warnings of Category E4xxx..... 294
9.2.1	E4001 Double MST failure shutdown..... 294
9.2.2	E4002 Double MDT failure shutdown..... 295
9.2.3	E4005 No command value input via master communication..... 296
9.2.4	E4006 Communication module overload..... 297
9.2.5	E4007 SERCOS III: Consumer connection failed..... 297
9.2.6	E4008 Invalid addressing command value data container A..... 297
9.2.7	E4009 Invalid addressing actual value data container A..... 298
9.2.8	E4010 Slave not scanned or address 0..... 298
9.2.9	E4011 Communication watchdog: Overload of cyclic communication..... 299
9.2.10	E4012 Maximum number of CCD slaves exceeded..... 299
9.2.11	E4013 Incorrect CCD addressing..... 299
9.2.12	E4014 Incorrect phase switch of CCD slaves..... 300
9.2.13	E4016 CCD: Topology error..... 301
9.2.14	E4017 CCD: Unknown I/O configuration..... 301
9.3	Possible Warnings When Operating Safety Technology (E3xxx)..... 302
9.3.1	Behavior in Case a Safety Technology Warning Occurs..... 302
9.3.2	E3100 Error when checking input signals..... 302
9.3.3	E3101 Error when checking acknowledgment signal..... 303
9.3.4	E3102 Actual position values validation error..... 304
9.3.5	E3103 Dynamization failed..... 304
9.3.6	E3104 Safety parameters validation error..... 305
9.3.7	E3105 Validation error of safe operation mode..... 305
9.3.8	E3106 System error safety technology..... 306
9.3.9	E3107 Safe reference missing..... 307
9.3.10	E3108 Safely-monitored deceleration exceeded..... 307
9.3.11	E3110 Time interval of forced dynamization exceeded..... 308
9.3.12	E3115 Prewarning, end of brake check time interval..... 309
9.3.13	E3116 Nominal load torque of holding system reached..... 309
9.4	Non-Fatal Warnings (E2xxx)..... 310
9.4.1	Behavior in Case a Non-Fatal Warning Occurs..... 310
9.4.2	E2010 Position control with encoder 2 not possible..... 310
9.4.3	E2011 PLC - Warning no. 1..... 310

Table of Contents

	Page
9.4.4	E2012 PLC - Warning no. 2..... 311
9.4.5	E2013 PLC - Warning no. 3..... 311
9.4.6	E2014 PLC - Warning no. 4..... 311
9.4.7	E2015 PLC - Warning no. 5..... 312
9.4.8	E2016 PLC - Warning no. 6..... 312
9.4.9	E2017 PLC - Warning no. 7..... 312
9.4.10	E2021 Motor temperature outside of measuring range..... 313
9.4.11	E2026 Undervoltage in power section..... 314
9.4.12	E2040 Device overtemperature 2 prewarning..... 315
9.4.13	E2047 Interpolation velocity = 0..... 315
9.4.14	E2048 Interpolation acceleration = 0..... 316
9.4.15	E2049 Positioning velocity \geq limit value..... 317
9.4.16	E2050 Device overtemp. prewarning..... 318
9.4.17	E2051 Motor overtemp. prewarning..... 319
9.4.18	E2053 Target position out of travel range..... 319
9.4.19	E2054 Not homed..... 321
9.4.20	E2055 Feedrate override S-0-0108 = 0..... 321
9.4.21	E2056 Torque limit = 0..... 322
9.4.22	E2058 Selected positioning block has not been programmed..... 323
9.4.23	E2059 Velocity command value limit active..... 324
9.4.24	E2061 Device overload prewarning..... 324
9.4.25	E2063 Velocity command value $>$ limit value..... 325
9.4.26	E2064 Target position out of num. range..... 326
9.4.27	E2069 Holding brake torque too low..... 326
9.4.28	E2070 Acceleration limit active..... 327
9.4.29	E2074 Encoder 1: Encoder signals disturbed..... 328
9.4.30	E2075 Encoder 2: Encoder signals disturbed..... 328
9.4.31	E2076 Measuring encoder: Encoder signals disturbed..... 329
9.4.32	E2077 Absolute encoder monitoring, motor encoder (encoder alarm)..... 330
9.4.33	E2078 Absolute encoder monitoring, opt. encoder (encoder alarm)..... 331
9.4.34	E2079 Absolute enc. monitoring, measuring encoder (encoder alarm)..... 331
9.4.35	E2086 Prewarning supply module overload..... 332
9.4.36	E2092 Internal synchronization defective..... 332
9.4.37	E2100 Positioning velocity of master axis generator too high..... 333
9.4.38	E2101 Acceleration of master axis generator is zero..... 334
9.4.39	E2140 CCD error at node..... 334
9.4.40	E2270 Analog input 1 or 2, wire break..... 334
9.4.41	E2802 HW control of braking resistor..... 335
9.4.42	E2810 Drive system not ready for operation..... 336
9.4.43	E2814 Undervoltage in mains..... 336
9.4.44	E2816 Undervoltage in power section..... 337
9.4.45	E2818 Phase failure..... 337
9.4.46	E2819 Mains failure..... 338
9.4.47	E2820 Braking resistor overload prewarning..... 338
9.4.48	E2829 Not ready for power on..... 339

Table of Contents

	Page
10 Diagnostic Command Messages.....	341
10.1 Commands.....	341
10.1.1 C0100 Communication phase 3 transition check.....	341
10.1.2 C0200 Exit parameterization level procedure command.....	341
10.1.3 C0300 Set absolute position procedure command.....	341
10.1.4 C0400 Activate parameterization level 1 procedure command.....	342
10.1.5 C0500 Reset class 1 diagnostics, error reset.....	342
10.1.6 C0600 Drive-controlled homing procedure command.....	342
10.1.7 C0700 Load defaults proced. command (motor-spec. controller val.).....	343
10.1.8 C0720 Load defaults procedure command (safety technology).....	344
10.1.9 C0730 Load defaults procedure command (MLD).....	345
10.1.10 C0740 Command Activate field bus profile settings.....	345
10.1.11 C0750 Load defaults procedure command (factory settings).....	346
10.1.12 C0800 Load basic parameters command.....	346
10.1.13 C0900 Position spindle command.....	347
10.1.14 C1200 Commutation offset setting command.....	347
10.1.15 C1300 Positive stop drive procedure command.....	347
10.1.16 C1400 Command Get marker position.....	348
10.1.17 C1500 Cancel reference point procedure command.....	348
10.1.18 C1600 Parking axis command.....	348
10.1.19 C1700 Command measuring wheel mode.....	349
10.1.20 C1800 Command Drive optimization / command value box.....	349
10.1.21 C2000 Command Release motor holding brake.....	349
10.1.22 C2100 Command Holding system check.....	350
10.1.23 C2200 Backup working memory procedure command.....	350
10.1.24 C2300 Load working memory procedure command.....	350
10.1.25 C2400 Selectively backup working memory procedure command.....	351
10.1.26 C2500 Copy IDN from optional memory to internal memory.....	351
10.1.27 C2600 Copy IDN from internal memory to optional memory.....	352
10.1.28 C2800 Analog input adjustment command.....	352
10.1.29 C2900 Command Firmware update from MMC.....	353
10.1.30 C3000 Synchronize and store safety technology IDN.....	353
10.1.31 C3100 Recalculate actual value cycle.....	354
10.1.32 C3200 Command Calculate motor data.....	354
10.1.33 C3300 Set coordinate system procedure command.....	354
10.1.34 C3400 Shift coordinate system procedure command.....	355
10.1.35 C3500 Command Determine encoder correction values.....	355
10.1.36 C3600 Command Motor data identification.....	355
10.1.37 C3700 Manually unlocking the safety door.....	356
10.1.38 C3800 Command Apply motor holding brake.....	356
10.1.39 C3900 Command Holding brake resurfacing.....	357
10.1.40 C4000 Homing procedure command channel 2.....	357
10.1.41 C4100 Switch parameter set command.....	357
10.1.42 C4200 Drive-controlled oscillation command.....	357
10.1.43 C4300 NC-controlled homing procedure command.....	358
10.1.44 C4400 Calculate displacement procedure command.....	358

Table of Contents

	Page
10.1.45	C4500 Displacement to referenced system procedure command..... 358
10.1.46	C4600 Command Calculate motor control parameters..... 359
10.1.47	C4700 Command Activate easy startup mode..... 359
10.1.48	C4800 Command Determine cogging torque compensation table..... 359
10.1.49	C4900 PLC command..... 360
10.1.50	C5200 Communication phase 4 transition check..... 360
10.1.51	C5300 SERCOS III: Command SYNC delay measurement..... 360
10.1.52	C5400 Command Save PLC retain data on MMC..... 361
10.1.53	C5500 Command Load PLC retain data from MMC..... 361
10.1.54	C5600 Command subsequent optimization of commutation offset..... 362
10.1.55	C5800 Command Apply redundant holding brake..... 362
10.1.56	C5900 Command Resurfacing of redundant holding brake..... 362
10.1.57	C6000 Set absolute position procedure command..... 363
10.1.58	C6100 Command Activate IP settings..... 363
10.1.59	C6200 Command Enabling SM without valid brake status..... 364
10.1.60	C6400 Reboot command..... 365
10.1.61	C6500 Save operating data on backup memory..... 365
10.1.62	C6600 Restore operating data from backup memory..... 365
10.1.63	C7000 CCD: Command adjust slave addresses..... 366
10.1.64	C7100 CCD: Command Close ring..... 366
10.1.65	C7200 CCD: Command Apply I/O configuration..... 366
10.1.66	C7400 CCD: Switching to phase 2..... 367
10.1.67	C7500 CCD: Switching to phase 4..... 367
10.1.68	C7600 Command Create parameter image..... 367
10.2	Command Errors..... 368
10.2.1	Clearing Command Errors..... 368
10.2.2	C0101 Invalid parameters (-> S-0-0021)..... 368
10.2.3	C0102 Limit error in parameter (-> S-0-0021)..... 368
10.2.4	C0103 Parameter conversion error (->S-0-0021)..... 369
10.2.5	C0104 Config. IDN for MDT not configurable..... 369
10.2.6	C0105 Maximum length for MDT exceeded..... 370
10.2.7	C0106 Config. IDNs for AT not configurable..... 370
10.2.8	C0107 Maximum length for AT exceeded..... 371
10.2.9	C0108 Time slot parameter > Sercos cycle time..... 371
10.2.10	C0109 Telegram offset unsuitable..... 372
10.2.11	C0110 Length of MDT (S-0-0010) odd..... 373
10.2.12	C0111 ID9 + Record length - 1 > length MDT (S-0-0010)..... 374
10.2.13	C0112 TNcyc (S-0-0001) or TScyc (S-0-0002) error..... 374
10.2.14	C0113 Relation TNcyc (S-0-0001) to TScyc (S-0-0002) error..... 375
10.2.15	C0114 T4 > TScyc (S-0-0002) - T4min (S-0-0005)..... 375
10.2.16	C0115 T2 too small..... 376
10.2.17	C0116 T3 (S-0-0008) within MDT (S-0-0089 + S-0-0010)..... 376
10.2.18	C0118 Order of cyclic command value configuration incorrect..... 377
10.2.19	C0119 Max. travel range too large..... 377
10.2.20	C0120 Error when reading encoder data => motor encoder..... 378
10.2.21	C0121 Incorrect parameterization of motor encoder (hardware)..... 378

Table of Contents

	Page
10.2.22 C0122 Incorr. parameteriz. of motor enc. (mechanical system).....	379
10.2.23 C0123 Modulo value for motor encoder cannot be displayed.....	379
10.2.24 C0124 Motor encoder unknown.....	380
10.2.25 C0125 Error when reading encoder data => optional encoder.....	381
10.2.26 C0126 Incorrect parameterization of optional enc. (hardware).....	381
10.2.27 C0127 Incorr. parameteriz. of opt. enc. (mechanical system).....	382
10.2.28 C0128 Modulo value for optional encoder cannot be displayed.....	382
10.2.29 C0129 Optional encoder unknown.....	383
10.2.30 C0130 Maximum travel range cannot be displayed internally.....	383
10.2.31 C0131 Switching to phase 3 impossible.....	384
10.2.32 C0132 Invalid settings for controller cycle times.....	384
10.2.33 C0134 Invalid motor data in encoder memory (->S-0-0021).....	385
10.2.34 C0135 Type of construction of motor P-0-4014 incorrect.....	386
10.2.35 C0136 Several motor encoders connected.....	386
10.2.36 C0137 Error during initialization of motor data (->S-0-0021).....	387
10.2.37 C0138 Invalid control section data (->S-0-0021).....	387
10.2.38 C0139 T2 (S-0-0089)+length MDT (S-0-0010)>TScyc (S-0-0002).....	388
10.2.39 C0140 Rotary scaling not allowed.....	388
10.2.40 C0151 IDN for command value data container not allowed.....	389
10.2.41 C0152 IDN for actual value data container not allowed.....	389
10.2.42 C0153 Error at init. of synchr. motor with reluctance torque.....	390
10.2.43 C0154 Field bus: IDN for cycl. command val. not configurable.....	390
10.2.44 C0155 Field bus: Max. length for cycl. command val. exceeded.....	391
10.2.45 C0156 Field bus: IDN for cycl. actual val. not configurable.....	391
10.2.46 C0157 Field bus: Length for cycl. actual values exceeded.....	392
10.2.47 C0158 Field bus: Tcyc (P-0-4076) incorrect.....	392
10.2.48 C0159 Field bus: P-0-4077 missing for cycl. command values.....	393
10.2.49 C0160 Error when reading encoder data => measuring encoder.....	393
10.2.50 C0161 Incorr. parameterization of measuring enc. (hardware).....	394
10.2.51 C0162 Measuring encoder unknown.....	394
10.2.52 C0163 Modulo value for measuring encoder cannot be displayed.....	395
10.2.53 C0164 Incorrect measuring encoder configuration.....	395
10.2.54 C0170 Config. IDNs for connection not configurable.....	396
10.2.55 C0171 Maximum length for connections exceeded.....	396
10.2.56 C0172 Delay measurement (S-0-1024) not carried out.....	397
10.2.57 C0173 Connections (number) not configurable.....	397
10.2.58 C0174 Connection configuration not allowed.....	397
10.2.59 C0175 Producer cycle time of a connection not correct.....	398
10.2.60 C0199 Functional package selection changed. Restart.....	398
10.2.61 C0201 Invalid parameters (->S-0-0423).....	399
10.2.62 C0202 Parameter limit error (->S-0-0423).....	399
10.2.63 C0203 Parameter conversion error (->S-0-0423).....	400
10.2.64 C0210 Feedback 2 required (->S-0-0423).....	401
10.2.65 C0212 Invalid control section data (->S-0-0423).....	401
10.2.66 C0218 Double signal selection master axis format converter.....	402
10.2.67 C0219 Max. travel range too large.....	402

Table of Contents

	Page
10.2.68	C0220 Error when initializing position of encoder 1..... 403
10.2.69	C0221 Initialization velocity encoder 1 too high..... 404
10.2.70	C0223 Invalid settings for controller cycle times..... 404
10.2.71	C0224 Error when initializing position of encoder 2..... 404
10.2.72	C0225 Initialization velocity encoder 2 too high..... 405
10.2.73	C0227 Error when initializing position of measuring encoder..... 405
10.2.74	C0228 Initialization velocity measuring encoder too high..... 406
10.2.75	C0229 Field bus: IDN for cycl. command val. not configurable..... 407
10.2.76	C0230 Field bus: Max. length for cycl. command val. exceeded..... 407
10.2.77	C0231 Field bus: IDN for cycl. actual val. not configurable..... 407
10.2.78	C0232 Field bus: Length for cycl. actual values exceeded..... 408
10.2.79	C0233 Field bus: Tcyc (P-0-4076) incorrect..... 408
10.2.80	C0234 Field bus: P-0-4077 missing for cycl. command values..... 409
10.2.81	C0238 Order of cyclic command value configuration incorrect..... 409
10.2.82	C0239 IDN for command value data container not allowed..... 410
10.2.83	C0240 IDN for actual value data container not allowed..... 410
10.2.84	C0241 Incorrect parameterization of motion task..... 411
10.2.85	C0242 Multiple configuration of a parameter (->S-0-0423)..... 411
10.2.86	C0243 Brake check function not possible..... 413
10.2.87	C0244 Act. modulo value cycle greater than max. travel range..... 414
10.2.88	C0245 Operation mode configuration (->S-0-0423) not allowed..... 415
10.2.89	C0246 Trav. range lim. switch not ass. to dig. input..... 416
10.2.90	C0247 Dig. output already assigned to other axis..... 417
10.2.91	C0248 Dig. input assigned differently to axes..... 417
10.2.92	C0249 Dig. I/Os: Bit number too large..... 418
10.2.93	C0250 Probe inputs incorrectly configured..... 418
10.2.94	C0251 Error during synchronization to master communication..... 419
10.2.95	C0252 Incorrect MLD initialization (write access->S-0-0423)..... 419
10.2.96	C0253 Error in combination operation mode - encoder (->S-0-0423)..... 420
10.2.97	C0254 Configuration error PROFIsafe..... 420
10.2.98	C0255 Safety command for system init. incorrect..... 421
10.2.99	C0256 Safety technology configuration error..... 421
10.2.100	C0257 Error in safety technology encoder initialization..... 422
10.2.101	C0258 Error in relation TNcyc (S-0-0001) to fine interpol..... 423
10.2.102	C0259 MLD configuration error (->S-0-0423)..... 423
10.2.103	C0260 Incremental enc. emulator resol. cannot be displayed..... 424
10.2.104	C0261 Emulator (P-0-0902) activated for both axes..... 425
10.2.105	C0265 Incorrect CCD address configuration..... 425
10.2.106	C0266 Incorrect CCD phase switch..... 426
10.2.107	C0267 CCD timeout phase switch..... 426
10.2.108	C0270 Error when reading encoder data => motor encoder..... 427
10.2.109	C0271 Incorrect parameterization of motor encoder (hardware)..... 428
10.2.110	C0272 Incorr. parameteriz. of motor enc. (mechanical system)..... 428
10.2.111	C0273 Modulo value for motor encoder cannot be displayed..... 429
10.2.112	C0274 Motor encoder unknown..... 429
10.2.113	C0275 Error when reading encoder data => optional encoder..... 430

Table of Contents

	Page
10.2.114 C0276 Incorrect parameterization of optional enc. (hardware).....	430
10.2.115 C0277 Incorr. parameteriz. of opt. enc. (mechanical system).....	431
10.2.116 C0278 Modulo value for optional encoder cannot be displayed.....	431
10.2.117 C0279 Optional encoder unknown.....	432
10.2.118 C0280 Maximum travel range cannot be displayed internally.....	433
10.2.119 C0281 Commutation via encoder-2 impossible.....	433
10.2.120 C0282 Sensorless posit. of synchr. motors, invalid ctrl parameters.....	434
10.2.121 C0283 Error during initialization of motor control (->S-0-0423).....	434
10.2.122 C0284 Invalid motor data in encoder memory (->S-0-0423).....	435
10.2.123 C0285 Type of construction of motor P-0-4014 incorrect.....	436
10.2.124 C0286 Several motor encoders connected.....	437
10.2.125 C0287 Error during initialization of motor data (->S-0-0423).....	437
10.2.126 C0288 Rotary scaling not allowed.....	439
10.2.127 C0289 Error at init. of synchr. motor with reluctance torque.....	439
10.2.128 C0290 Error when reading encoder data => measuring encoder.....	440
10.2.129 C0291 Incorr. parameterization of measuring enc. (hardware).....	441
10.2.130 C0292 Measuring encoder unknown.....	442
10.2.131 C0293 Modulo value for measuring encoder cannot be displayed.....	442
10.2.132 C0294 Incorrect measuring encoder configuration.....	443
10.2.133 C0298 Impossible to exit parameterization level.....	443
10.2.134 C0299 Configuration changed. Restart.....	444
10.2.135 C0301 Measuring system unavailable.....	444
10.2.136 C0302 Absolute evaluation of measuring system impossible.....	445
10.2.137 C0303 Absolute encoder offset cannot be saved.....	445
10.2.138 C0401 Switching not allowed.....	446
10.2.139 C0403 Switching to CCD phase 2 impossible.....	446
10.2.140 C0501 Error clearing only in parameter mode.....	447
10.2.141 C0601 Homing only possible with drive enable.....	447
10.2.142 C0602 Distance home switch - reference mark erroneous.....	448
10.2.143 C0603 Homing impossible with optional encoder.....	448
10.2.144 C0604 Homing impossible with absolute encoder.....	449
10.2.145 C0606 Reference mark not detected.....	449
10.2.146 C0607 Reference cam input not assigned.....	450
10.2.147 C0608 Pos. stop a. HW lim. switch not allowed f. modulo axes.....	450
10.2.148 C0609 Different travel directions parameterized.....	450
10.2.149 C0610 Absolute encoder offset could not be saved.....	451
10.2.150 C0702 Default parameters not available.....	451
10.2.151 C0703 Default parameters invalid.....	452
10.2.152 C0704 Parameters not copyable.....	452
10.2.153 C0706 Error when reading the controller parameters.....	453
10.2.154 C0722 Parameter default value incorrect (-> S-0-0423).....	453
10.2.155 C0723 Safety command for load defaults procedure incorrect.....	454
10.2.156 C0724 Timeout of safety command for load defaults procedure.....	454
10.2.157 C0751 Parameter default value incorrect (-> S-0-0423).....	455
10.2.158 C0752 Locked with password.....	456
10.2.159 C0799 An invalid index was set.....	456

Table of Contents

	Page
10.2.160 C0851 Parameter default value incorrect (-> S-0-0021).....	457
10.2.161 C0852 Locked with password.....	457
10.2.162 C0902 Spindle positioning requires drive enable.....	457
10.2.163 C0903 Error during initialization.....	458
10.2.164 C0906 Error during search for zero pulse.....	458
10.2.165 C1204 Error in offset calculation.....	459
10.2.166 C1208 No adjustment with asynchronous motor.....	459
10.2.167 C1209 Proceed to phase 4.....	459
10.2.168 C1211 Commutation offset could not be determined.....	460
10.2.169 C1212 Motion range exceeded during commutation.....	460
10.2.170 C1214 Command only possible with linear synchronous motor.....	461
10.2.171 C1215 Command only possible in 'bb'.....	461
10.2.172 C1216 Commutation determination not selected.....	462
10.2.173 C1217 Setting only possible in 'Ab'.....	462
10.2.174 C1218 Automatic commutation: Current too low.....	462
10.2.175 C1219 Automatic commutation: Overcurrent.....	463
10.2.176 C1220 Automatic commutation: Timeout.....	464
10.2.177 C1221 Automatic commutation: Iteration without result.....	464
10.2.178 C1222 Error when writing offset parameters.....	465
10.2.179 C1223 Command execution impossible.....	465
10.2.180 C1301 Class 1 diagnostics error at command start.....	466
10.2.181 C1402 Faulty reference mark signal.....	466
10.2.182 C1701 Measuring wheel mode not possible.....	466
10.2.183 C1801 Start requires drive enable.....	467
10.2.184 C1802 Motor feedback data not valid.....	467
10.2.185 C1803 Inertia detection failed.....	468
10.2.186 C1804 Automatic controller setting failed.....	469
10.2.187 C1805 Travel range invalid.....	469
10.2.188 C1806 Travel range exceeded.....	470
10.2.189 C1807 Determining travel range only via travel distance.....	471
10.2.190 C1808 Drive not homed.....	471
10.2.191 C2001 Command not enabled.....	471
10.2.192 C2101 Holding system check only possible with drive enable.....	472
10.2.193 C2103 Holding brake: Torque too low.....	472
10.2.194 C2104 Command execution impossible.....	473
10.2.195 C2105 Load of holding system greater than test torque.....	473
10.2.196 C2106 Test torque of holding system not reached.....	474
10.2.197 C2107 Redundant holding brake: Torque too low.....	477
10.2.198 C2108 Error when releasing the holding system.....	477
10.2.199 C2109 SBS: Test torque invalid.....	478
10.2.200 C2202 Error when writing data to non-volatile memory.....	479
10.2.201 C2301 Error when reading non-volatile memory.....	479
10.2.202 C2302 Error when converting parameters.....	479
10.2.203 C2402 Error when saving parameters.....	480
10.2.204 C2502 Error when accessing the MMC.....	480
10.2.205 C2504 Error when writing data to internal memory.....	481

Table of Contents

	Page
10.2.206 C2602 Error when accessing the MMC.....	482
10.2.207 C2604 Error when reading the internal memory.....	483
10.2.208 C2801 Analog input not configured.....	483
10.2.209 C2802 Oscillations of input signal outside tolerance range.....	484
10.2.210 C2803 Measured values at zero point and max. value identical.....	484
10.2.211 C2804 Automatic adjustment failed.....	485
10.2.212 C2903 Error when accessing the MMC.....	485
10.2.213 C2904 Error when accessing the flash.....	486
10.2.214 C2905 Programmed firmware defective.....	486
10.2.215 C3001 Synchronization and storage failed.....	487
10.2.216 C3101 Act. modulo value cycle greater than max. travel range.....	488
10.2.217 C3102 Drive is still in drive enable.....	488
10.2.218 C3201 Incorrect input for current.....	488
10.2.219 C3202 Incorrect input for voltage.....	489
10.2.220 C3203 Incorrect input for frequency.....	489
10.2.221 C3204 Incorrect input for speed.....	489
10.2.222 C3205 Incorrect input for power factor.....	490
10.2.223 C3206 Incorrect input for power.....	490
10.2.224 C3207 Type plate list incomplete.....	491
10.2.225 C3208 Error when writing parameters (->S-0-0423).....	491
10.2.226 C3209 Command execution impossible.....	491
10.2.227 C3501 Acquisition velocity not allowed.....	492
10.2.228 C3502 Motor encoder not available.....	492
10.2.229 C3503 Optional encoder not available.....	493
10.2.230 C3504 Measuring encoder not available.....	493
10.2.231 C3505 No encoder selected.....	494
10.2.232 C3506 Correction value table cannot be stored.....	494
10.2.233 C3601 Motor not or not correctly connected.....	495
10.2.234 C3602 Determined values invalid.....	495
10.2.235 C3603 Device current limit too low.....	496
10.2.236 C3604 Error when writing parameters (->S-0-0423).....	496
10.2.237 C3605 Motor turning.....	497
10.2.238 C3606 Type of construction of motor not allowed.....	497
10.2.239 C3607 Motor revolution/motion impeded.....	498
10.2.240 C3608 Incorrect motor phases or rotational direction of encoder.....	498
10.2.241 C3609 Incorrect number of pole pairs or number of encoder lines.....	499
10.2.242 C3610 No encoder: Validation check impossible.....	499
10.2.243 C3611 Test velocity not reached.....	500
10.2.244 C3701 Error when manually unlocking the safety door.....	500
10.2.245 C3901 Resurfacing of holding brake only possible with drive enable.....	501
10.2.246 C3902 Error during resurfacing of holding brake.....	501
10.2.247 C3903 Command execution impossible.....	502
10.2.248 C4001 Error during safe homing procedure.....	502
10.2.249 C4002 Incorrect distance of dedicated point channel 1-2.....	503
10.2.250 C4101 Switching only possible without AF.....	504
10.2.251 C4102 Switching only possible in parameter mode.....	504

Table of Contents

	Page
10.2.252 C4103 Preselect parameter set forbidden value.....	505
10.2.253 C4104 Error during parameter set switching (->S-0-0423).....	505
10.2.254 C4201 Oscillation requires drive enable.....	505
10.2.255 C4202 Oscillation command speed cannot be reached.....	506
10.2.256 C4302 Distance home switch - reference mark erroneous.....	506
10.2.257 C4304 Homing impossible with absolute encoder.....	507
10.2.258 C4306 Reference mark not detected.....	507
10.2.259 C4307 Reference cam input not assigned.....	508
10.2.260 C4308 Pos. stop a. HW lim. switch not allowed f. modulo axes.....	508
10.2.261 C4601 Error when writing parameters (->S-0-0423).....	508
10.2.262 C4701 Drive active, activation of easy startup impossible.....	509
10.2.263 C4801 Cogging torque compensation: Measuring vel. too high.....	509
10.2.264 C4802 Cogging torque compensation: Measuring vel. too low.....	510
10.2.265 C4803 Cogging torque compensation: Inadmissible acceleration.....	510
10.2.266 C4804 Cogging torque comp.: Err. when storing corr. val table.....	511
10.2.267 C4805 Cogging torque comp.: Motor measuring system not homed.....	511
10.2.268 C4901 PLC command error no. 1.....	512
10.2.269 C4902 PLC command error no. 2.....	512
10.2.270 C4903 PLC command error no. 3.....	512
10.2.271 C4904 PLC command error no. 4.....	513
10.2.272 C4910 PLC command timeout.....	513
10.2.273 C5301 SERCOS III: Delay measurement failed.....	514
10.2.274 C5401 PLC program not ready for retain data backup.....	514
10.2.275 C5402 Error when writing data to the MMC.....	515
10.2.276 C5501 PLC program not ready for loading retain data.....	515
10.2.277 C5502 MMC not available or not OK.....	516
10.2.278 C5503 PLC retain data do not match PLC program.....	516
10.2.279 C5504 Unknown format in PLC retain file.....	517
10.2.280 C5505 Invalid PLC retain data.....	517
10.2.281 C5601 Command requires drive enable.....	518
10.2.282 C5602 Axis blocked.....	518
10.2.283 C5603 Timeout: Axis in motion.....	518
10.2.284 C5801 Command Apply redundant holding brake not possible.....	519
10.2.285 C5901 Comm. Resurfacing of red. holding brake only possible AF.....	519
10.2.286 C5902 Error when resurfacing redundant holding brake.....	520
10.2.287 C5903 Command execution impossible.....	520
10.2.288 C6001 Measuring system unavailable.....	521
10.2.289 C6002 Absolute evaluation of measuring system impossible.....	521
10.2.290 C6003 Absolute encoder offset cannot be saved.....	522
10.2.291 C6004 Command cannot be executed under drive enable.....	522
10.2.292 C6101 Incorrect IP settings.....	522
10.2.293 C6201 Command execution impossible.....	523
10.2.294 C6401 reboot command impossible.....	524
10.2.295 C6501 Error when writing backup data (backup memory).....	524
10.2.296 C6502 Error when reading backup data (device).....	525
10.2.297 C6503 Error when checking backup data (comparison).....	526

Table of Contents

	Page
10.2.298 C6601 Error when reading backup data (backup memory).....	526
10.2.299 C6602 Error when writing backup data (device).....	527
10.2.300 C6603 Error when writing comparative data (backup memory).....	528
10.2.301 C6604 Error when reading comparative data (device).....	529
10.2.302 C6605 Warning, restoration incomplete (device).....	529
10.2.303 C7001 CCD: Impossible to adjust slave addresses.....	530
10.2.304 C7101 CCD: Impossible to close ring.....	531
10.2.305 C7201 CCD: Impossible to apply I/O configuration.....	531
10.2.306 C7401 CCD: Impossible to switch to phase 2.....	532
10.2.307 C7501 CCD: Impossible to switch to phase 4.....	532
10.2.308 C7601 Memory access impossible.....	533
10.2.309 C7602 Slave access impossible.....	533
11 Extended Diagnosis (P-0-3219).....	535
11.1 Displays C0254 to C0265.....	535
11.2 Displays C0723 to C2109.....	537
11.3 Displays C4001, C4002 and C6201.....	538
11.4 Displays Exxx, E3107 and E3115.....	539
11.5 Displays F3112 to F3135.....	539
11.6 Display F3140.....	544
11.7 Displays F3141 and F3142.....	547
11.8 Displays F3144 to F3152.....	548
11.9 Displays F7010 to F7022.....	551
11.10 Displays F7030 to F7031.....	552
11.11 Displays F7040 to F7043.....	553
11.12 Displays F7050 to F7051.....	554
11.13 Displays F8027 to F8135.....	556
11.14 Display F8201.....	557
12 Extended Diagnosis (P-0-3219) as of MPx07.....	559
12.1 Displays C0254 to C0265.....	559
12.2 Displays C0723 to C2109.....	561
12.3 Displays C4001, C4002 and C6201.....	563
12.4 Displays Exxx, E3107 and E3115.....	563
12.5 Displays F3112 to F3135.....	564
12.6 Display F3140.....	570
12.7 Displays F3141 and F3142.....	573
12.8 Displays F3144 to F3152.....	574
12.9 Displays F7010 to F7022.....	576
12.10 Displays F7030 to F7031.....	577
12.11 Displays F7040 to F7043.....	579
12.12 Displays F7050 to F7051.....	581
12.13 Displays F8030 to F8135.....	583
12.14 Display F8201.....	584

Table of Contents

	Page
13 Rexroth IndraDrive Mi Diagnostic Display.....	585
13.1 KSM Distributed Servo Drive / KMS Distributed Drive Controller.....	585
13.1.1 LED H14.....	585
13.1.2 Diagnostic Display as of MPB-07V12 / MPx-08VRS.....	585
13.1.3 Diagnostic Display up to MPB-07V10.....	586
13.2 Electronic Control System KCU.....	587
14 Handling, Diagnostic and Service Functions.....	589
14.1 Firmware Replacement.....	589
14.2 Firmware Download.....	589
14.3 Messages During Firmware Download.....	589
14.4 FL: DL	589
14.5 FL:ERASE	590
14.6 FL: PROG	590
14.7 FL: CKS	590
14.8 FL:E ADR	590
14.9 FL:E SEC	590
14.10 FL:E FW	590
14.11 FL:E LD	591
14.12 FL:E SEQ	591
14.13 FL:F9002	591
14.14 FL:F2100	591
14.15 FL:F CKS	591
14.16 FL:F ACC	592
14.17 FL:F2101	592
14.18 FL:F8122	592
14.19 FL:F8129	592
14.20 FL:F8130	592
14.21 FL:F8120	593
15 Notes for Machine Operators.....	595
15.1 General Information.....	595
15.2 Diagnosing Malfunction and Removing Errors.....	595
15.3 Contacting the Service Department	596
16 Notes for Installation Programmers.....	597
16.1 How to Handle Command Errors.....	597
16.2 How to Handle Errors.....	599
16.3 How to Handle Warnings.....	601
17 Service and Support.....	603
Index.....	605

1 Introduction

1.1 About This Documentation

Editions of This Documentation

Edition	Release date	Notes
DOK-INDRV*-GEN-**VRS**-WA01-EN-P	2004-03-17	First edition
DOK-INDRV*-GEN-**VRS**-WA02-EN-P	2004-11-26	Also valid for MPx03 firmware
DOK-INDRV*-GEN-**VRS**-WA03-EN-P	2005-12-23	Also valid for MPx04 firmware
DOK-INDRV*-GEN-**VRS**-WA04-EN-P	2007-10-05	Also valid for MPx05 firmware
DOK-INDRV*-GEN-**VRS**-WA05-EN-P	2009-05-07	Also valid for MPx06 firmware
DOK-INDRV*-GEN-**VRS**-WA06-EN-P	2009-09-11	Also valid for MPx07 firmware
DOK-INDRV*-GEN-**VRS**-WA07-EN-P	2011-01-14	Also valid for MPx08 firmware
DOK-INDRV*-GEN-**VRS**-WA08-EN-P	2012-01-10	"Rexroth IndraDrive Mi Diagnostic Display" included Corrections and improvements

Fig. 1-1: Record of Revisions

Means of Representation in This Documentation

To make the reading of this documentation easier for you, the table below contains the means of representation and notations of recurring terms.

What?	How?	For example...
Important facts which are to be highlighted in the body text	Boldface	With the safety function "Safe parking axis", the following monitoring functions are deactivated : ...
Parameter names, diagnostic message names, function designations	Quotation marks	The missing speed information can be replaced via the control bit "defined safety with parked axis" in "P-0-3210, Safety technology configuration".

Fig. 1-2: Conventions of Notation

Notes and tips are highlighted. A symbol tells you whether a note or a tip is used in the text:



This box contains important information which you should take into consideration.



This symbol highlights useful tips and tricks.

The reader's attention is drawn to hazards in accordance with ANSI Z535.6-2011 (see "Explanation of Signal Words and the Safety Alert Symbol").

Your Feedback

Your experience is important for our improvement processes of products and documentations.

If you discover mistakes in this documentation or suggest changes, you can send your feedback to the following e-mail address:

Dokusupport@boschrexroth.de

We need the following information to handle your feedback:

Introduction

- The number indicated under "Internal File Reference".
- The page number.

1.2 Reference Documentations

1.2.1 Drive Systems, System Components

Title Rexroth IndraDrive ...	Kind of documentation	Document typecode ¹⁾ DOK-INDRV*-...	Part number R911...
Drive Systems With HMV01/02 HMS01/02, HMD01, HCS02/03	Project Planning Manual	SYSTEM****-PRxx-EN-P	309636
Mi Drive Systems	Project Planning Manual	KCU+KSM****-PRxx-EN-P	320924
Supply Units, Power Sections HMV, HMS, HMD, HCS02, HCS03	Project Planning Manual	HMV-S-D+HCS-PRxx-EN-P	318790
Drive Controllers Control Sections CSB01, CSH01, CDB01	Project Planning Manual	CSH*****-PRxx-EN-P	295012
Additional Components and Accesso- ries	Project Planning Manual	ADDCOMP****-PRxx-EN-P	306140
C Drive Controllers HCS02.1, HCS03.1	Operating Instructions	FU*****-IBxx-EN-P	314905

- 1) In the document typecodes, "xx" is a wild card for the current edition of the documentation (example: PR01 is the first edition of a Project Planning Manual)

Fig.1-3: Documentations – Overview

Title	Kind of documentation	Document typecode ¹⁾	Part number R911...
Automation Terminals Of The Rexroth Inline Product Range	Application Manual	DOK-CONTRL-ILSYSINS***- AWxx-EN-P	317021

- 1) In the document typecodes, "xx" is a wild card for the current edition of the documentation (example: AW01 is the first edition of an Application Manual)

Fig.1-4: Documentations – Overview

1.2.2 Motors

Title Rexroth IndraDyn ...	Kind of documentation	Document typecode ¹⁾ DOK-MOTOR*-...	Part number R911...
A Asynchronous Motors MAD / MAF	Project Planning Manual	MAD/MAF****-PRxx-EN-P	295781
H Synchronous Kit Spindle Motors	Project Planning Manual	MBS-H*****-PRxx-EN-P	297895
L Synchronous Linear Motors	Project Planning Manual	MLF*****-PRxx-EN-P	293635

Title Rexroth IndraDyn ...	Kind of documentation	Document typecode ¹⁾ DOK-MOTOR*-...	Part number R911...
S MSK Synchronous Motors	Project Planning Manual	MSK*****-PRxx-EN-P	296289
T Synchronous Torque Motors	Project Planning Manual	MBT*****-PRxx-EN-P	298798

1) In the document typecodes, "xx" is a wild card for the current edition of the documentation (example: PR01 is the first edition of a Project Planning Manual)

Fig. 1-5: Documentations – Overview

1.2.3 Cables

Title Rexroth Connection Cables IndraDrive and IndraDyn	Kind of documentation	Document typecode ¹⁾ DOK-...	Part number R911...
	Selection Data	CONNEX-CABLE*INDRV-CAxx-EN-P	322949

1) In the document typecodes, "xx" is a wild card for the current edition of the documentation (example: CA02 is the second edition of the documentation "Selection Data")

Fig. 1-6: Documentations – Overview

1.2.4 Firmware

Title Rexroth IndraDrive ...	Kind of documentation	Document typecode ¹⁾ DOK-INDRV*-...	Part number R911...
Firmware for Drive Controllers MPH-08, MPB-08, MPD-08, MPC-08	Functional Description	MP*-08VRS**-APxx-EN-P	332643
Firmware for Drive Controllers MPH-07, MPB-07, MPD-07, MPC-07	Functional Description	MP*-07VRS**-FKxx-EN-P	328670
Firmware for Drive Controllers MPH-06, MPB-06, MPD-06, MPC-06	Functional Description	MP*-06VRS**-FKxx-EN-P	326766
Firmware for Drive Controllers MPH-05, MPB-05, MPD-05	Functional Description	MP*-05VRS**-FKxx-EN-P	320182
Firmware for Drive Controllers MPH-04, MPB-04, MPD-04	Functional Description	MP*-04VRS**-FKxx-EN-P	315485
Firmware for Drive Controllers MPH-03, MPB-03, MPD-03	Functional Description	MP*-03VRS**-FKxx-EN-P	308329
Firmware for Drive Controllers MPH-02, MPB-02, MPD-02	Functional Description	MP*-02VRS**-FKxx-EN-P	299223
Drive Controllers MPx-02 to MPx-08	Parameter Description	GEN-**VRS**-PAxx-EN-P	297317
MPx-02 to MPx-08 and HMV	Troubleshooting Guide	GEN-**VRS**-WAxx-EN-P	297319
Integrated Safety Technology	Functional and Application Description	SI*-**VRS**-FKxx-EN-P	297838

Introduction

Title	Kind of documentation	Document typecode ¹⁾	Part number
Rexroth IndraDrive ...		DOK-INDRV*-...	R911...
Integrated Safety Technology According to IEC61508	Functional Description	SI2-**VRS**-FKxx-EN-P	327664
Rexroth IndraMotion MLD	Application Manual	MLD-**VRS**-AWxx-EN-P	306084
Rexroth IndraMotion MLD Library	Library Description	MLD-SYSLIB*-FKxx-EN-P	309224

1) In the document typecodes, "xx" is a wild card for the current edition of the documentation (example: FK02 is the second edition of a Functional Description)

Fig. 1-7: Documentations – Overview

Title	Kind of documentation	Document typecode ¹⁾	Part number
Productivity Agent Extended Diagnostic Functions With Rexroth IndraDrive	Application Manual	DOK-INDRV*-MLD-PAGENT*- AWxx-EN-P	323947

1) In the document typecodes, "xx" is a wild card for the current edition of the documentation (example: AW01 is the first edition of an Application Manual)

Fig. 1-8: Documentations – Overview

2 Important Directions for Use

2.1 Appropriate Use

2.1.1 Introduction

Rexroth products represent state-of-the-art developments and manufacturing. They are tested prior to delivery to ensure operating safety and reliability.

⚠ WARNING

Personal injury and property damage caused by incorrect use of the products!

The products have been designed for use in the industrial environment and may only be used in the appropriate way. If they are not used in the appropriate way, situations resulting in property damage and personal injury can occur.



Rexroth as manufacturer is not liable for any damages resulting from inappropriate use. In such cases, the guarantee and the right to payment of damages resulting from inappropriate use are forfeited. The user alone carries all responsibility of the risks.

Before using Rexroth products, make sure that all the pre-requisites for an appropriate use of the products are satisfied:

- Personnel that in any way, shape or form uses our products must first read and understand the relevant safety instructions and be familiar with appropriate use.
- If the products take the form of hardware, then they must remain in their original state, in other words, no structural changes are permitted. It is not permitted to decompile software products or alter source codes.
- Do not mount damaged or faulty products or use them in operation.
- Make sure that the products have been installed in the manner described in the relevant documentation.

2.1.2 Areas of Use and Application

Drive controllers made by Rexroth are designed to control electrical motors and monitor their operation.

Control and monitoring of the Drive controllers may require additional sensors and actors.



The drive controllers may only be used with the accessories and parts specified in this documentation. If a component has not been specifically named, then it may neither be mounted nor connected. The same applies to cables and lines.

Operation is only permitted in the specified configurations and combinations of components using the software and firmware as specified in the relevant Functional Descriptions.

Drive controllers have to be programmed before commissioning, making it possible for the motor to execute the specific functions of an application.

Drive controllers of the Rexroth IndraDrive line have been developed for use in single- and multi-axis drive and control tasks.

Important Directions for Use

To ensure application-specific use of Drive controllers, device types of different drive power and different interfaces are available.

Typical applications include, for example:

- Handling and mounting systems,
- Packaging and food machines,
- Printing and paper processing machines and
- Machine tools.

Drive controllers may only be operated under the assembly and installation conditions described in this documentation, in the specified position of normal use and under the ambient conditions as described (temperature, degree of protection, humidity, EMC, etc.).

2.2 Inappropriate Use

Using the Drive controllers outside of the operating conditions described in this documentation and outside of the indicated technical data and specifications is defined as "inappropriate use".

Drive controllers must not be used, if ...

- they are subject to operating conditions that do not meet the specified ambient conditions. This includes, for example, operation under water, under extreme temperature fluctuations or extremely high maximum temperatures.
- Furthermore, Drive controllers must not be used in applications which have not been expressly authorized by Rexroth. Please carefully follow the specifications outlined in the general Safety Instructions!



Components of the drive system Rexroth IndraDrive are **products of category C3** (with restricted distribution) according to IEC 61800-3. These components are not provided for use in a public low-voltage mains supplying residential areas. If these components are used in such a mains, high-frequency interference is to be expected. This can require additional measures of radio interference suppression.

3 Safety Instructions for Electric Drives and Controls

3.1 Definitions of Terms

Application Documentation	Application documentation comprises the entire documentation used to inform the user of the product about the use and safety-relevant features for configuring, integrating, installing, mounting, commissioning, operating, maintaining, repairing and decommissioning the product. The following terms are also used for this kind of documentation: User Guide, Operation Manual, Commissioning Manual, Instruction Manual, Project Planning Manual, Application Manual, etc.
Component	A component is a combination of elements with a specified function, which are part of a piece of equipment, device or system. Components of the electric drive and control system are, for example, supply units, drive controllers, mains choke, mains filter, motors, cables, etc.
Control System	A control system comprises several interconnected control components placed on the market as a single functional unit.
Device	A device is a finished product with a defined function, intended for users and placed on the market as an individual piece of merchandise.
Electrical Equipment	Electrical equipment encompasses all devices used to generate, convert, transmit, distribute or apply electrical energy, such as electric motors, transformers, switching devices, cables, lines, power-consuming devices, circuit board assemblies, plug-in units, control cabinets, etc.
Electric Drive System	An electric drive system comprises all components from mains supply to motor shaft; this includes, for example, electric motor(s), motor encoder(s), supply units and drive controllers, as well as auxiliary and additional components, such as mains filter, mains choke and the corresponding lines and cables.
Installation	An installation consists of several devices or systems interconnected for a defined purpose and on a defined site which, however, are not intended to be placed on the market as a single functional unit.
Machine	A machine is the entirety of interconnected parts or units at least one of which is movable. Thus, a machine consists of the appropriate machine drive elements, as well as control and power circuits, which have been assembled for a specific application. A machine is, for example, intended for processing, treatment, movement or packaging of a material. The term "machine" also covers a combination of machines which are arranged and controlled in such a way that they function as a unified whole.
Manufacturer	The manufacturer is an individual or legal entity bearing responsibility for the design and manufacture of a product which is placed on the market in the individual's or legal entity's name. The manufacturer can use finished products, finished parts or finished elements, or contract out work to subcontractors. However, the manufacturer must always have overall control and possess the required authority to take responsibility for the product.
Product	Examples of a product: Device, component, part, system, software, firmware, among other things.
Project Planning Manual	A project planning manual is part of the application documentation used to support the sizing and planning of systems, machines or installations.
Qualified Persons	In terms of this application documentation, qualified persons are those persons who are familiar with the installation, mounting, commissioning and operation of the components of the electric drive and control system, as well as with the hazards this implies, and who possess the qualifications their work

Safety Instructions for Electric Drives and Controls

requires. To comply with these qualifications, it is necessary, among other things,

- 1) to be trained, instructed or authorized to switch electric circuits and devices safely on and off, to ground them and to mark them
- 2) to be trained or instructed to maintain and use adequate safety equipment
- 3) to attend a course of instruction in first aid

User A user is a person installing, commissioning or using a product which has been placed on the market.

3.2 General Information

3.2.1 Using the Safety Instructions and Passing Them on to Others

Do not attempt to install and operate the components of the electric drive and control system without first reading all documentation provided with the product. Read and understand these safety instructions and all user documentation prior to working with these components. If you do not have the user documentation for the components, contact your responsible Rexroth sales partner. Ask for these documents to be sent immediately to the person or persons responsible for the safe operation of the components.

If the component is resold, rented and/or passed on to others in any other form, these safety instructions must be delivered with the component in the official language of the user's country.

Improper use of these components, failure to follow the safety instructions in this document or tampering with the product, including disabling of safety devices, could result in property damage, injury, electric shock or even death.

3.2.2 Requirements for Safe Use

Read the following instructions before initial commissioning of the components of the electric drive and control system in order to eliminate the risk of injury and/or property damage. You must follow these safety instructions.

- Rexroth is not liable for damages resulting from failure to observe the safety instructions.
- Read the operating, maintenance and safety instructions in your language before commissioning. If you find that you cannot completely understand the application documentation in the available language, please ask your supplier to clarify.
- Proper and correct transport, storage, mounting and installation, as well as care in operation and maintenance, are prerequisites for optimal and safe operation of the component.
- Only qualified persons may work with components of the electric drive and control system or within its proximity.
- Only use accessories and spare parts approved by Rexroth.
- Follow the safety regulations and requirements of the country in which the components of the electric drive and control system are operated.
- Only use the components of the electric drive and control system in the manner that is defined as appropriate. See chapter "Appropriate Use".
- The ambient and operating conditions given in the available application documentation must be observed.
- Applications for functional safety are only allowed if clearly and explicitly specified in the application documentation "Integrated Safety Technolo-

Safety Instructions for Electric Drives and Controls

gy". If this is not the case, they are excluded. Functional safety is a safety concept in which measures of risk reduction for personal safety depend on electrical, electronic or programmable control systems.

- The information given in the application documentation with regard to the use of the delivered components contains only examples of applications and suggestions.

The machine and installation manufacturers must

- make sure that the delivered components are suited for their individual application and check the information given in this application documentation with regard to the use of the components,
- make sure that their individual application complies with the applicable safety regulations and standards and carry out the required measures, modifications and complements.
- Commissioning of the delivered components is only allowed once it is sure that the machine or installation in which the components are installed complies with the national regulations, safety specifications and standards of the application.
- Operation is only allowed if the national EMC regulations for the application are met.
- The instructions for installation in accordance with EMC requirements can be found in the section on EMC in the respective application documentation.

The machine or installation manufacturer is responsible for compliance with the limit values as prescribed in the national regulations.

- The technical data, connection and installation conditions of the components are specified in the respective application documentations and must be followed at all times.

National regulations which the user must take into account

- European countries: In accordance with European EN standards
- United States of America (USA):
 - National Electrical Code (NEC)
 - National Electrical Manufacturers Association (NEMA), as well as local engineering regulations
 - Regulations of the National Fire Protection Association (NFPA)
- Canada: Canadian Standards Association (CSA)
- Other countries:
 - International Organization for Standardization (ISO)
 - International Electrotechnical Commission (IEC)

3.2.3 Hazards by Improper Use

- High electrical voltage and high working current! Danger to life or serious injury by electric shock!
- High electrical voltage by incorrect connection! Danger to life or injury by electric shock!
- Dangerous movements! Danger to life, serious injury or property damage by unintended motor movements!
- Health hazard for persons with heart pacemakers, metal implants and hearing aids in proximity to electric drive systems!

Safety Instructions for Electric Drives and Controls

- Risk of burns by hot housing surfaces!
- Risk of injury by improper handling! Injury by crushing, shearing, cutting, hitting!
- Risk of injury by improper handling of batteries!
- Risk of injury by improper handling of pressurized lines!

3.3 Instructions with Regard to Specific Dangers

3.3.1 Protection Against Contact With Electrical Parts and Housings



This section concerns components of the electric drive and control system with voltages of **more than 50 volts**.

Contact with parts conducting voltages above 50 volts can cause personal danger and electric shock. When operating components of the electric drive and control system, it is unavoidable that some parts of these components conduct dangerous voltage.

High electrical voltage! Danger to life, risk of injury by electric shock or serious injury!

- Only qualified persons are allowed to operate, maintain and/or repair the components of the electric drive and control system.
- Follow the general installation and safety regulations when working on power installations.
- Before switching on, the equipment grounding conductor must have been permanently connected to all electric components in accordance with the connection diagram.
- Even for brief measurements or tests, operation is only allowed if the equipment grounding conductor has been permanently connected to the points of the components provided for this purpose.
- Before accessing electrical parts with voltage potentials higher than 50 V, you must disconnect electric components from the mains or from the power supply unit. Secure the electric component from reconnection.
- With electric components, observe the following aspects:
Always wait **30 minutes** after switching off power to allow live capacitors to discharge before accessing an electric component. Measure the electrical voltage of live parts before beginning to work to make sure that the equipment is safe to touch.
- Install the covers and guards provided for this purpose before switching on.
- Never touch electrical connection points of the components while power is turned on.
- Do not remove or plug in connectors when the component has been powered.
- Under specific conditions, electric drive systems can be operated at mains protected by residual-current-operated circuit-breakers sensitive to universal current (RCDs/RCMs).
- Secure built-in devices from penetrating foreign objects and water, as well as from direct contact, by providing an external housing, for example a control cabinet.

High housing voltage and high leakage current! Danger to life, risk of injury by electric shock!

- Before switching on and before commissioning, ground or connect the components of the electric drive and control system to the equipment grounding conductor at the grounding points.

Safety Instructions for Electric Drives and Controls

- Connect the equipment grounding conductor of the components of the electric drive and control system permanently to the main power supply at all times. The leakage current is greater than 3.5 mA.
- Establish an equipment grounding connection with a minimum cross section according to the table below. With an outer conductor cross section smaller than 10 mm² (8 AWG), the alternative connection of two equipment grounding conductors is allowed, each having the same cross section as the outer conductors.

Cross section outer conductor	Minimum cross section equipment grounding conductor Leakage current ≥ 3.5 mA	
	1 equipment grounding conductor	2 equipment grounding conductors
1,5 mm ² (AWG 16)	10 mm ² (AWG 8)	2 × 1,5 mm ² (AWG 16)
2,5 mm ² (AWG 14)		2 × 2,5 mm ² (AWG 14)
4 mm ² (AWG 12)		2 × 4 mm ² (AWG 12)
6 mm ² (AWG 10)		2 × 6 mm ² (AWG 10)
10 mm ² (AWG 8)		-
16 mm ² (AWG 6)	16 mm ² (AWG 6)	-
25 mm ² (AWG 4)		-
35 mm ² (AWG 2)		-
50 mm ² (AWG 1/0)	25 mm ² (AWG 4)	-
70 mm ² (AWG 2/0)	35 mm ² (AWG 2)	-
...

Fig.3-1: Minimum Cross Section of the Equipment Grounding Connection

3.3.2 Protective Extra-Low Voltage as Protection Against Electric Shock

Protective extra-low voltage is used to allow connecting devices with basic insulation to extra-low voltage circuits.

On components of an electric drive and control system provided by Rexroth, all connections and terminals with voltages between 5 and 50 volts are PELV ("Protective Extra-Low Voltage") systems. It is allowed to connect devices equipped with basic insulation (such as programming devices, PCs, notebooks, display units) to these connections.

Danger to life, risk of injury by electric shock! High electrical voltage by incorrect connection!

If extra-low voltage circuits of devices containing voltages and circuits of more than 50 volts (e.g., the mains connection) are connected to Rexroth products, the connected extra-low voltage circuits must comply with the requirements for PELV ("Protective Extra-Low Voltage").

3.3.3 Protection Against Dangerous Movements

Dangerous movements can be caused by faulty control of connected motors. Some common examples are:

- Improper or wrong wiring or cable connection
- Operator errors
- Wrong input of parameters before commissioning
- Malfunction of sensors and encoders
- Defective components
- Software or firmware errors

These errors can occur immediately after equipment is switched on or even after an unspecified time of trouble-free operation.

The monitoring functions in the components of the electric drive and control system will normally be sufficient to avoid malfunction in the connected drives. Regarding personal safety, especially the danger of injury and/or property damage, this alone cannot be relied upon to ensure complete safety. Until the integrated monitoring functions become effective, it must be assumed in any case that faulty drive movements will occur. The extent of faulty drive movements depends upon the type of control and the state of operation.

Dangerous movements! Danger to life, risk of injury, serious injury or property damage!

A **risk assessment** must be prepared for the installation or machine, with its specific conditions, in which the components of the electric drive and control system are installed.

As a result of the risk assessment, the user must provide for monitoring functions and higher-level measures on the installation side for personal safety. The safety regulations applicable to the installation or machine must be taken into consideration. Unintended machine movements or other malfunctions are possible if safety devices are disabled, bypassed or not activated.

To avoid accidents, injury and/or property damage:

- Keep free and clear of the machine's range of motion and moving machine parts. Prevent personnel from accidentally entering the machine's range of motion by using, for example:
 - Safety fences
 - Safety guards
 - Protective coverings
 - Light barriers
- Make sure the safety fences and protective coverings are strong enough to resist maximum possible kinetic energy.
- Mount emergency stopping switches in the immediate reach of the operator. Before commissioning, verify that the emergency stopping equipment works. Do not operate the machine if the emergency stopping switch is not working.
- Prevent unintended start-up. Isolate the drive power connection by means of OFF switches/OFF buttons or use a safe starting lockout.
- Make sure that the drives are brought to safe standstill before accessing or entering the danger zone.

Safety Instructions for Electric Drives and Controls

- Additionally secure vertical axes against falling or dropping after switching off the motor power by, for example,
 - mechanically securing the vertical axes,
 - adding an external braking/arrester/clamping mechanism or
 - ensuring sufficient counterbalancing of the vertical axes.
- The standard equipment **motor holding brake** or an external holding brake controlled by the drive controller is **not sufficient to guarantee personal safety!**
- Disconnect electrical power to the components of the electric drive and control system using the master switch and secure them from reconnection ("lock out") for:
 - Maintenance and repair work
 - Cleaning of equipment
 - Long periods of discontinued equipment use
- Prevent the operation of high-frequency, remote control and radio equipment near components of the electric drive and control system and their supply leads. If the use of these devices cannot be avoided, check the machine or installation, at initial commissioning of the electric drive and control system, for possible malfunctions when operating such high-frequency, remote control and radio equipment in its possible positions of normal use. It might possibly be necessary to perform a special electromagnetic compatibility (EMC) test.

3.3.4 Protection Against Magnetic and Electromagnetic Fields During Operation and Mounting

Magnetic and electromagnetic fields generated by current-carrying conductors or permanent magnets of electric motors represent a serious danger to persons with heart pacemakers, metal implants and hearing aids.

Health hazard for persons with heart pacemakers, metal implants and hearing aids in proximity to electric components!

- Persons with heart pacemakers and metal implants are not allowed to enter the following areas:
 - Areas in which components of the electric drive and control systems are mounted, commissioned and operated.
 - Areas in which parts of motors with permanent magnets are stored, repaired or mounted.
- If it is necessary for somebody with a heart pacemaker to enter such an area, a doctor must be consulted prior to doing so. The noise immunity of implanted heart pacemakers differs so greatly that no general rules can be given.
- Those with metal implants or metal pieces, as well as with hearing aids, must consult a doctor before they enter the areas described above.

3.3.5 Protection Against Contact With Hot Parts

Hot surfaces of components of the electric drive and control system. Risk of burns!

Safety Instructions for Electric Drives and Controls

- Do not touch hot surfaces of, for example, braking resistors, heat sinks, supply units and drive controllers, motors, windings and laminated cores!
- According to the operating conditions, temperatures of the surfaces can be **higher than 60 °C** (140 °F) during or after operation.
- Before touching motors after having switched them off, let them cool down for a sufficient period of time. Cooling down can require **up to 140 minutes!** The time required for cooling down is approximately five times the thermal time constant specified in the technical data.
- After switching chokes, supply units and drive controllers off, wait **15 minutes** to allow them to cool down before touching them.
- Wear safety gloves or do not work at hot surfaces.
- For certain applications, and in accordance with the respective safety regulations, the manufacturer of the machine or installation must take measures to avoid injuries caused by burns in the final application. These measures can be, for example: Warnings at the machine or installation, guards (shieldings or barriers) or safety instructions in the application documentation.

3.3.6 Protection During Handling and Mounting

Risk of injury by improper handling! Injury by crushing, shearing, cutting, hitting!

- Observe the relevant statutory regulations of accident prevention.
- Use suitable equipment for mounting and transport.
- Avoid jamming and crushing by appropriate measures.
- Always use suitable tools. Use special tools if specified.
- Use lifting equipment and tools in the correct manner.
- Use suitable protective equipment (hard hat, safety goggles, safety shoes, safety gloves, for example).
- Do not stand under hanging loads.
- Immediately clean up any spilled liquids from the floor due to the risk of falling!

3.3.7 Battery Safety

Batteries consist of active chemicals in a solid housing. Therefore, improper handling can cause injury or property damage.

Risk of injury by improper handling!

- Do not attempt to reactivate low batteries by heating or other methods (risk of explosion and cauterization).
- Do not attempt to recharge the batteries as this may cause leakage or explosion.
- Do not throw batteries into open flames.
- Do not dismantle batteries.
- When replacing the battery/batteries, do not damage the electrical parts installed in the devices.
- Only use the battery types specified for the product.

Safety Instructions for Electric Drives and Controls



Environmental protection and disposal! The batteries contained in the product are considered dangerous goods during land, air, and sea transport (risk of explosion) in the sense of the legal regulations. Dispose of used batteries separately from other waste. Observe the national regulations of your country.

3.3.8 Protection Against Pressurized Systems

According to the information given in the Project Planning Manuals, motors and components cooled with liquids and compressed air can be partially supplied with externally fed, pressurized media, such as compressed air, hydraulics oil, cooling liquids and cooling lubricants. Improper handling of the connected supply systems, supply lines or connections can cause injuries or property damage.

Risk of injury by improper handling of pressurized lines!

- Do not attempt to disconnect, open or cut pressurized lines (risk of explosion).
- Observe the respective manufacturer's operating instructions.
- Before dismounting lines, relieve pressure and empty medium.
- Use suitable protective equipment (safety goggles, safety shoes, safety gloves, for example).
- Immediately clean up any spilled liquids from the floor due to the risk of falling!



Environmental protection and disposal! The agents (e.g., fluids) used to operate the product might not be environmentally friendly. Dispose of agents harmful to the environment separately from other waste. Observe the national regulations of your country.

3.4 Explanation of Signal Words and the Safety Alert Symbol

The Safety Instructions in the available application documentation contain specific signal words (DANGER, WARNING, CAUTION or NOTICE) and, where required, a safety alert symbol (in accordance with ANSI Z535.6-2011).

The signal word is meant to draw the reader's attention to the safety instruction and identifies the hazard severity.

The safety alert symbol (a triangle with an exclamation point), which precedes the signal words DANGER, WARNING and CAUTION, is used to alert the reader to personal injury hazards.

 **DANGER**

In case of non-compliance with this safety instruction, death or serious injury will occur.

Safety Instructions for Electric Drives and Controls

⚠ WARNING

In case of non-compliance with this safety instruction, death or serious injury could occur.

⚠ CAUTION

In case of non-compliance with this safety instruction, minor or moderate injury could occur.

NOTICE

In case of non-compliance with this safety instruction, property damage could occur.

4 Basics on Device Diagnosis

4.1 Diagnostic System

4.1.1 Coded Diagnostic Messages of the Drive

Brief Description

The drive provides a diagnostic system including different options that are basically divided into two groups:

- Recognizing and displaying the current drive status by means of drive-internal, priority-dependent generation of diagnostic messages
- Collective messages for various status messages

Additionally, there are parameters for all important operating data the values of which can be transmitted both via master communication (e.g., SERCOS) and a parameterization interface (RS-232/485 in the ASCII protocol or SIS protocol; see "Serial Communication").

Pertinent Parameters

- S-0-0030, Manufacturer version
- S-0-0095, Diagnostic message
- S-0-0140, Controller type
- S-0-0142, Application type
- S-0-0375, Diagnostic numbers list
- S-0-0390, Diagnostic message number
- P-0-0007, Display text of diagnostic message
- P-0-0009, Error number
- P-0-0478, Logbook event
- P-0-0479, Logbook time stamp
- P-0-3219, Extended safety technology diagnosis



For integrated safety technology, an extended diagnosis option is provided in the form of a safety technology error code. When certain safety technology errors occur, this error code can be read from parameter "P-0-3219, Extended safety technology diagnosis" which allows quick error diagnosis.

Drive-Internal Generation of Diagnostic Messages

Operating states, activities and reactions of the drive controller are detected by drive-internal generation of diagnostic messages and appear in coded form on the display of the control panel. In addition, these diagnostic messages can be transferred to a master (control) and displayed and evaluated in service and commissioning software (e.g., "IndraWorks Ds/D/MLD").

We distinguish the following categories of diagnostic messages (kinds of diagnostic messages):

- Errors
- Warnings
- Commands/command errors
- Status displays/operating states

Generally, the current diagnostic message with the highest priority is displayed or stored at the following locations in the drive:

Basics on Device Diagnosis

- **Display of the control panel and parameter "P-0-0007, Display text of diagnostic message"**
→ The diagnostic message number or, if applicable, text appears on the 8-digit display of the standard control panel. The current display is stored in parameter P-0-0007.
- **Parameter "S-0-0095, Diagnostic message"**
→ This parameter, in the form of plain text, contains the operating status of the drive at present relevant. Preceding the text is the respective content of parameter S-0-0390.
- **Parameter "S-0-0390, Diagnostic message number"**
→ The diagnostic message number shown on the display is stored in this parameter.

When a diagnostic message of the "error" category occurs, the corresponding diagnostic message number is stored in parameter "P-0-0009, Error number". When there isn't any error present, the value of parameter P-0-0009 equals zero.

In parameter "S-0-0375, Diagnostic numbers list", the last 50 diagnostic message numbers of parameter S-0-0390 are recorded in chronological order. When reading this list, the number of the diagnostic message that last occurred is displayed as parameter element 1.

Priorities of Display

The following priorities apply for displaying the current diagnostic message:

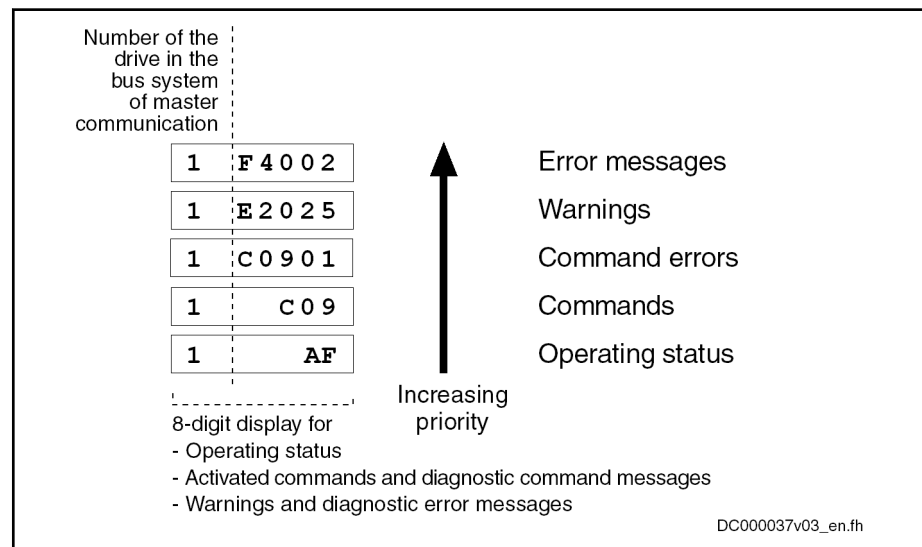

Fig.4-1: Priorities of Displays (with Example Displays)

The documentation "Troubleshooting Guide (description of diagnostic messages)" contains an overview of all diagnostic messages and their meanings.

Structure of a Diagnostic Message**General Information**

Every diagnostic message consists of

- Diagnostic message number
- and -
- diagnostic text.

The diagnostic message for the non-fatal error "F2028, Excessive deviation", for example, has the following structure:

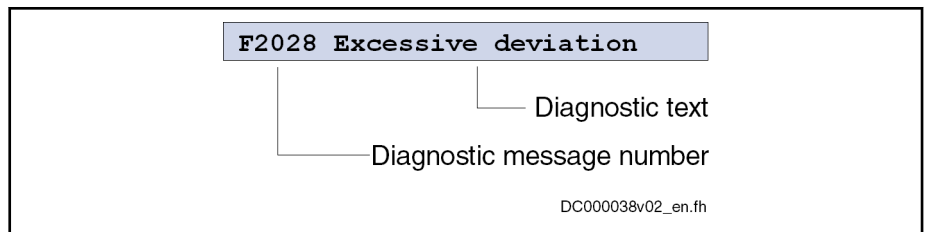

Fig.4-2: Structure of a Diagnostic Message

"F2028" flashes on the display of the control panel. The display "F2028" is also output via parameter "P-0-0007, Display text of diagnostic message", too. The diagnostic message number is contained in parameter "S-0-0390Diagnostic message number" in hexadecimal form (for this example: 0x00F2028). Parameter "S-0-0095, Diagnostic message" contains the diagnostic message number and the diagnostic text as string "F2028 Excessive deviation". "2028" (dec) is written to parameter "P-0-0009, Error number", because it is an error diagnosis.

Diagnostic message on the control panel display

The diagnostic message number appears on the 8-digit display of the standard control panel. This allows recognizing the current operating status of the drive quickly and without using a communication interface.

As a matter of principle, the following applies:

- Status displays (P0, Ab, AF ...) are displayed in right-aligned form
- Warnings, command errors and other error messages are flashing

Kind of diagnostic message	Diagnostic message number	Display
Error	F2xxx	F2xxx
Command	C0200	C02
Command error	C02xx	C02xx
Warning	E2xxx	E2xxx
communication phase e.g. communication phase 1	A0001	P1
Drive ready for operation	A0012	Ab
Operation mode e.g. velocity control	A0101	AF

Fig.4-3: Overview of Diagnostic Messages Displayed

The current operation mode is not shown on the display. When the drive follows the preset operating mode and no command was activated, the display reads "AF".

Diagnostic message in plain text

The diagnostic message in plain text contains the diagnostic message number followed by the diagnostic message text. It can be read via parameter "S-0-0095, Diagnostic message" and directly displayed on an operator interface as a language-dependent description of the drive status.

The diagnostic message in plain text is switched to the selected language via parameter "S-0-0265, Language selection".

Basics on Device Diagnosis

Diagnostic message number

The diagnostic message number contains only the diagnostic number without the diagnostic text. It can be read via parameter "S-0-0390, Diagnostic message number" and is a language-independent possibility of determining and displaying the drive status on an operator interface.

Display text of diagnostic message

The display text of a diagnostic message is the text appearing on the display of the control panel. It can be read via parameter "P-0-0007, Display text of diagnostic message" which allows an operator interface to determine the drive status and display it in a language-independent way.

Error number

The error number contains only the error number without the display text of the diagnostic message. It can be read via parameter "P-0-0009, Error number" and is a language-independent possibility of determining and displaying an error condition on an operator interface. This parameter only contains a value unequal to zero when an error is present in the drive.

The error number is generated from the lowest 4 digits of the diagnostic message number. For example, error "F2028 Excessive deviation" with diagnostic message number "(0x)F2028" results in error number "2028".

List of diagnostic numbers

The last 50 diagnostic message numbers displayed are stored in chronological order in parameter "S-0-0375, Diagnostic numbers list". Every change in the content of "S-0-0390, Diagnostic message number" means that the old content is applied to S-0-0375. When reading parameter S-0-0375, the last transferred diagnostic message number appears in the first element of the parameter, the diagnostic message number transferred before from S-0-0390 in the second element, etc.

Language Selection

Via parameter "S-0-0265Language selection", it is possible to define or change the language of diagnostic message texts.

 See also Parameter Description "S-0-0265, Language selection"

4.2 Status Classes, Status Displays, Control Parameters

4.2.1 General Information

In the drive there are many parameters with important status information (bit lists). Some of the bits contained in these lists can be used for configuring real-time status bits and additionally can be assigned to digital outputs or to the configurable signal status word.

See "Digital Inputs/Outputs"

See "Configurable Signal Status Word"

4.2.2 Status Classes

Brief Description

The drive differentiates between 3 states (error, warning and message) for which there is status information. To make the status information available, there are so-called class diagnostics parameters (S-0-0011, S-0-0012, S-0-0013) which contain the respective status bits.

In addition to these class diagnostics parameters, there are change bits contained in the status word of the field bus (e.g. S-0-0135 in the case of SERCOS) which display changes in one of the above-mentioned class diagnostics parameters (collective information).

- | | |
|-----------------------------|--|
| Features | <ul style="list-style-type: none">• Class diagnostics parameter for errors (cf. S-0-0011)• Class diagnostics parameter for warnings (cf. S-0-0012)• Class diagnostics parameter for messages (cf. S-0-0013)• Change bits in status word of master communication (e.g. S-0-0135 in case of SERCOS)• Change bits of class 2 and 3 diagnostics (S-0-0097 and S-0-0098) can be masked in the status word of master communication (e.g. S-0-0135 in case of SERCOS) to suppress individual bits or status messages |
| Pertinent Parameters | <ul style="list-style-type: none">• S-0-0011, Class 1 diagnostics• S-0-0012, Class 2 diagnostics• S-0-0013, Class 3 diagnostics• S-0-0097, Mask class 2 diagnostics• S-0-0098, Mask class 3 diagnostics• S-0-0135, Drive status word |

Functional Description

- | | |
|--------------------------------|---|
| Status Class Parameters | <ul style="list-style-type: none">• S-0-0011, Class 1 diagnostics (status parameter for drive errors)<ul style="list-style-type: none">– In case a drive error occurs, the bit assigned to the error is set in parameter S-0-0011. A separate bit is assigned in S-0-0011 to errors defined according to SERCOS.

Manufacturer-specific errors cause bit 15 to be set in parameter S-0-0011 (see also Parameter Description "S-0-0011, Class 1 diagnostics").– In case a drive error occurs, bit 13 (drive interlock; error in class 1 diagnostics) is simultaneously set in the status word of the field bus (S-0-0135 in case of SERCOS). |
|--------------------------------|---|



All bits in class 1 diagnostics are cleared by executing the command C0500 (reset class 1 diagnostics).

See also Parameter Description "S-0-0099, C0500 Reset class 1 diagnostics"

- **S-0-0012, Class 2 diagnostics** (status parameter for drive warnings)
 - In case a drive warning occurs, the bit assigned to the warning is set in parameter S-0-0012. A separate bit is assigned in S-0-0012 to warnings defined according to SERCOS.

Manufacturer-specific warnings cause bit 15 to be set in parameter S-0-0012 (see also Parameter Description "S-0-0012, Class 2 diagnostics").
 - In case a drive warning occurs, bit 12 (change bit class 2 diagnostics) is simultaneously set in the status word of the field bus (S-0-0135 in case of SERCOS), when the content of S-0-0012 changes (i.e. at least one bit toggles).
 - The bits in parameter S-0-0012 are automatically cleared when the warning disappears. The change bit in the status word of the master communication (S-0-0135 in case of SERCOS) remains set, however, until parameter S-0-0012 has been read once.

Basics on Device Diagnosis

 Via parameter "S-0-0097, Mask class 2 diagnostics", warnings can be masked in terms of their effect on the change bit.

- **S-0-0013, Class 3 diagnostics** (status parameter for drive messages)
 - Messages of the drive are listed in parameter S-0-0013. A separate bit is assigned in S-0-0013 to messages defined according to SERCOS (see also Parameter Description "S-0-0013, Class 3 diagnostics").
 - If a drive message occurs, bit 11 (change bit class 3 diagnostics) is simultaneously set in the status word of the field bus (S-0-0135 in case of SERCOS).
 - The bits in parameter S-0-0013 are automatically cleared when the message disappears. The change bit in the status word of the master communication (S-0-0135 in case of SERCOS) remains set, however, until parameter S-0-0013 has at least been read once.

 Each of these messages is stored in a separate parameter (S-0-0330 to S-0-0342).

Change Bits in Drive Status Word

If the status of a bit in "S-0-0012, Class 2 diagnostics" or "S-0-0013, Class 3 diagnostics" changes, the change bit for class 2 or 3 diagnostics is set in the field bus status word (e.g., S-0-0135 in case of SERCOS). A change bit in the status word (bit 11 or 12) is always set due to a change of the parameter content of S-0-0012 or S-0-0013. This enables the master to recognize very quickly whether a change occurred in S-0-0012 or S-0-0013.

A read access to one of the two parameters clears the respective change bit again.

Masking the Change Bits

By means of the parameters "S-0-0097, Mask class 2 diagnostics" and "S-0-0098, Mask class 3 diagnostics", it is possible to mask certain bits in terms of their effect on the change bit of the status word (bit 12 or bit 11).

The figure below illustrates the principle of masking by means of an example:

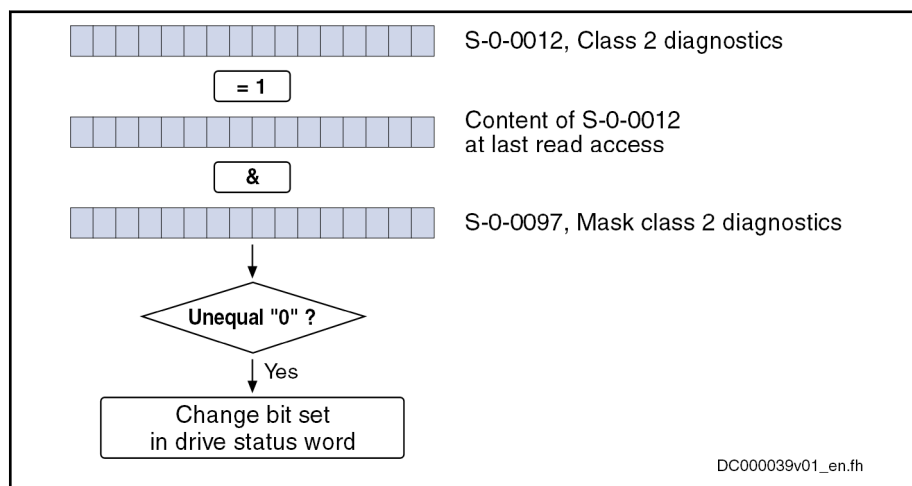

Fig.4-4: Generating the Change Bit of Class 2 Diagnostics

Notes on Commissioning

The figure below illustrates the handling of the change bits in the status word and of the status class parameters:

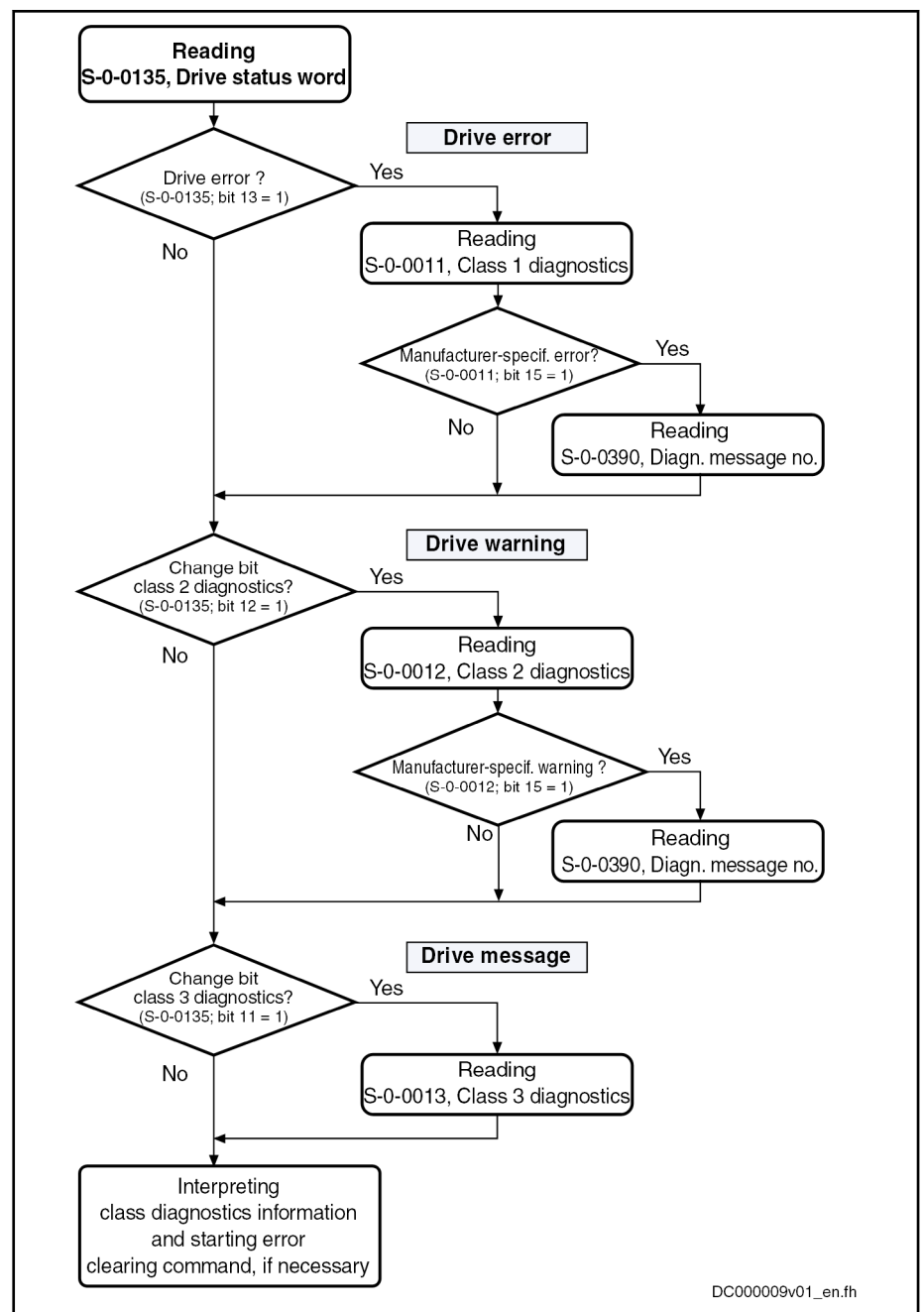

Fig.4-5: Handling the Change Bits and Status Class Parameters

4.2.3 Fixed Status Displays

Function-Related Status Parameters

In the drive there are parameters the content of which has a direct relation to the status of the sequence of different drive functions. These parameters are used to display the current status information of the assigned function.

The following parameters are available for function-related status display:

- **S-0-0014, Interface status**
 This parameter displays the status of the communication phase transition and the cyclic communication.
- **S-0-0135, Drive status word**

Basics on Device Diagnosis

This is the status word of the master communication (SERCOS) and contains all essential status information for the master.

- **S-0-0403, Position feedback value status**
This parameter contains status bits for the position data reference of the individual measuring systems.
- **S-0-0419, Positioning command acknowledge**
This status information is used for acknowledgment in "drive-controlled positioning" mode.
- **P-0-0046, Status word of current controller**
This parameter contains status bits of the internal motor control (e.g. overvoltage in DC bus).
- **P-0-0115, Device control: status word**
This parameter contains status bits of device control (see also "Device Control and State Machines").
- **P-0-0222, Travel range limit switch inputs**
This parameter displays the status of the travel range limit switch inputs (see also "Limitations: Travel Range Limit Switches").
- **P-0-0223, E-Stop input**
This parameter displays the status of the E-Stop input (see also "E-Stop Function").
- **P-0-0455, Acceleration feedforward actual value**
This parameter contains status bits to display the activation of torque/current limitation (see also "Limitations: Current and Torque/Force Limitation").
- **P-0-0539, Holding brake status word**
This parameter contains status bits for the status of the motor holding brake (see also "Motor Holding Brake").
- **P-0-0555, axis controller messages**
This parameter displays messages with regard to velocity and limits that have been reached.
- **P-0-4029, Diagnostic report SCSB module**
Parameter for reading master communication settings and states (with SERCOS interface).
- **P-0-4086, Master communication status**
This parameter displays control information of the master communication for handling phase switch, drive enable etc., defined during initialization.

Status Parameters for Real-Time Status Bits

The following list contains status parameters that only contain one bit and can therefore be used for configuring real-time status bits (see "SERCOS interface"):

- S-0-0330, Status "n_feedback = n_command"
- S-0-0331, Status "n_feedback = 0"
- S-0-0332, Status "n_feedback < nx"
- S-0-0333, Status "T >= Tx"
- S-0-0334, Status "T >= Tlimit"

- S-0-0335, Status "n_command > n_limit"
- S-0-0336, Status "In position"
- S-0-0337, Status "P >= Px"
- S-0-0341, Status "In coarse position"
- S-0-0342, Status "Target position attained"
- S-0-0343, Status "Interpolator halted"
- S-0-0409, Probe 1 positive latched
- S-0-0410, Probe 1 negative latched
- S-0-0411, Probe 2 positive latched
- S-0-0412, Probe 2 negative latched

4.2.4 Control Parameters

Apart from the parameters for status display, there are parameters available in the drive that are used to control the drive functions (see also description of corresponding parameter):

- P-0-0045, Control word of current controller
- P-0-0427, Control parameter of analog output
- P-0-0522, Control word for commutation setting
- P-0-0556, Config word of axis controller
- P-0-0612, Set absolute position control
- P-0-4028, Device control word

4.3 Control Panels of the IndraDrive Controllers

4.3.1 General Information on the Operation Options

Control Panel Variants

IndraDrive controllers are equipped with a "control panel"; its front consists of a display with keys located underneath it. The display shows operating states, command and error diagnostics, as well as any pending warnings. The keys are used to enter settings, call information and trigger some commands.



Fig. 4-6: Standard control panel

Via the serial interface of the controller, it is additionally possible to connect an independent **VCP operator terminal** that can, for example, be integrated in the front of the control cabinet.

VCP operator terminals are separate components (terminals) that can be used in addition to the standard or comfort control panel. They are connected to the serial interface of the controller via a separate line. This allows integrating a VCP operator terminal in the front of the control cabinet, for example.

Basics on Device Diagnosis

By means of a configuration tool it is additionally possible to configure other application-dependent settings, displays and command functions.

4.4 Control Panel

4.4.1 Brief Description

IndraDrive controllers are equipped with a control panel, the front of which, the so-called "control panel", consists of a display and 4 keys located underneath it. The four keys can be used to display extended diagnostic messages and trigger simple commands (in addition to master communication, IndraWorks or NC control).

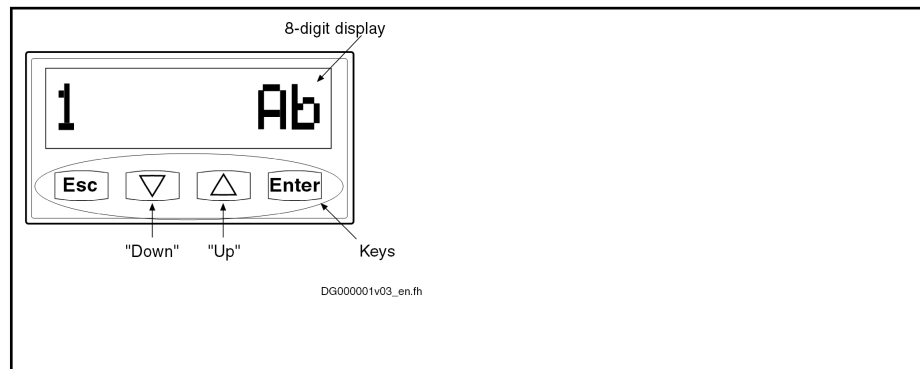

Fig.4-7: Schematic diagram of the control panel (sample display)

Control panel display options

The display of the IndraDrive controller automatically shows:

- Status of the master communication
- Operating status
- Commands and diagnostic command messages
- Warnings and diagnostic error messages
- Extended displays such as contents of error memories, diagnostic message memory, operating hours counter of control section, operating hours counter of power section, type designation of firmware active in the device, safety technology code (if safety technology option available)

Setting options using the control panel

The following settings can be performed using the control panel:

- Setting the drive address (drive number in the bus system of the master communication)
- Setting the length of the fiber optic cable
- Activating "Easy startup" mode for initial commissioning
- Setting the master communication protocol
- Setting IP addresses for Engineering

Activating commands via the control panel

The following commands can be activated using the control panel:

- Activating "S-0-0262, C07_x Load defaults procedure command" (loading controller parameters or basic parameters)
- Activating other commands, such as:
 - C0200 Exit parameterization level procedure command
 - C0300 Set absolute position procedure command
 - C0400 Activate parameterization level 1 procedure command
 - C2000 Command Release motor holding brake

- C2200 Backup working memory procedure command
- C2300 Load working memory procedure command
- C2800 Analog input adjustment command
- C2900 Command Firmware update from MMC

VCP control terminal It is also possible to connect a stand-alone **VCP control terminal** that can, for example, be integrated into the front of the control cabinet, to the controller via an Engineering interface.

VCP control terminals are separate components (terminals) that can be used in addition to the control panel. They are connected to the controller serially or by Ethernet.

VCPs are programmable by the user and it is possible to access all the drive's parameters and the MLD's variables.

4.4.2 Functional Description

Standard displays

The displays have priorities, because it is impossible to display several messages simultaneously.

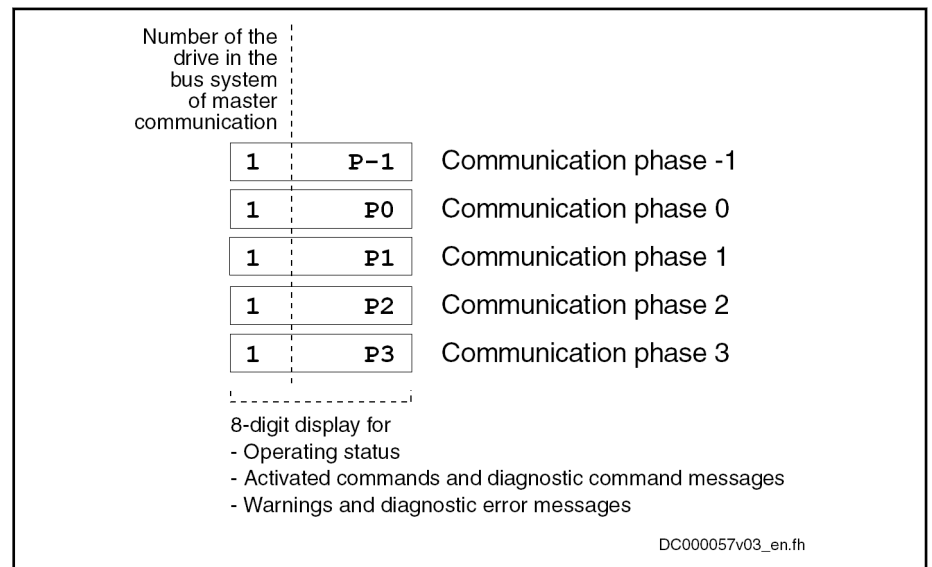

Fig.4-8: Displays during phase progression of the master communication

Basics on Device Diagnosis

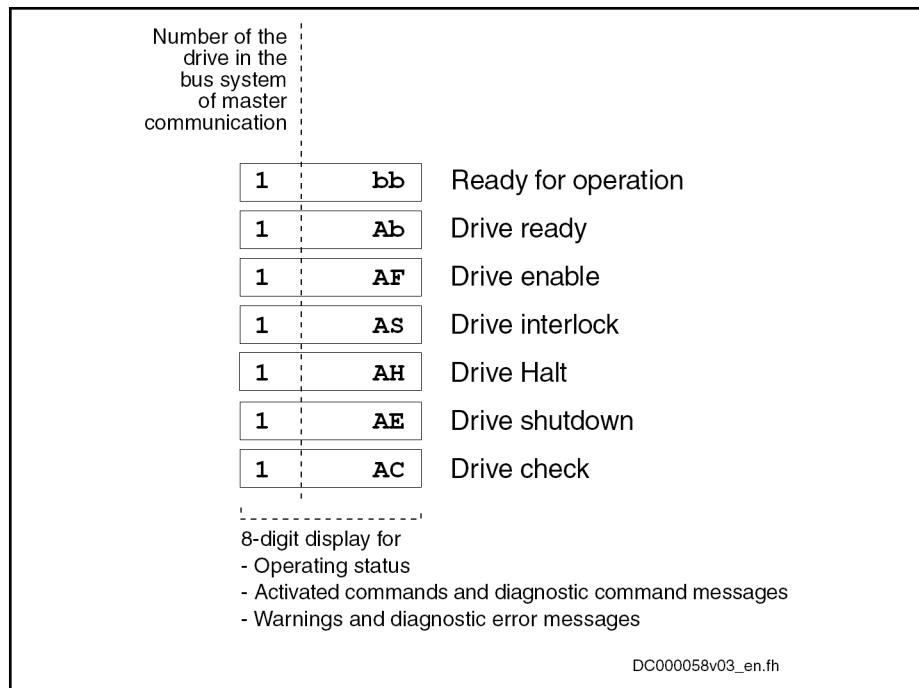

Fig.4-9: Displays during phase progression of the master communication

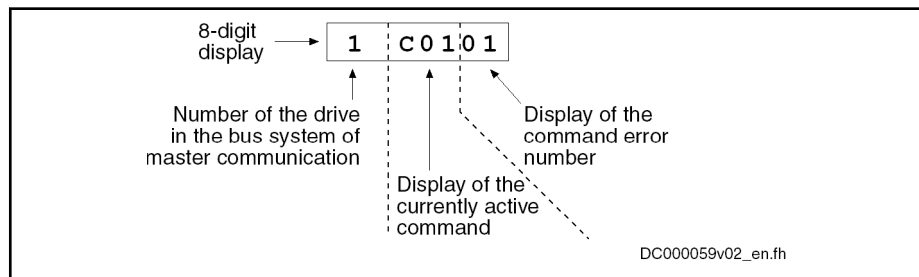

Fig.4-10: Explanation of command error displays

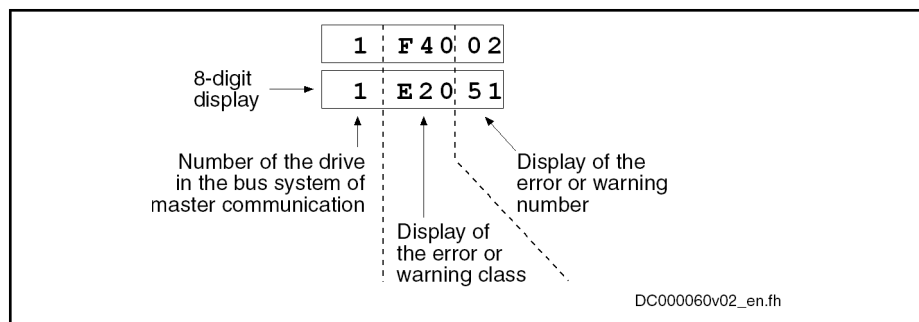

Fig.4-11: Explanation of error and warning displays

Priorities of display

The current drive status is displayed with highest priority.

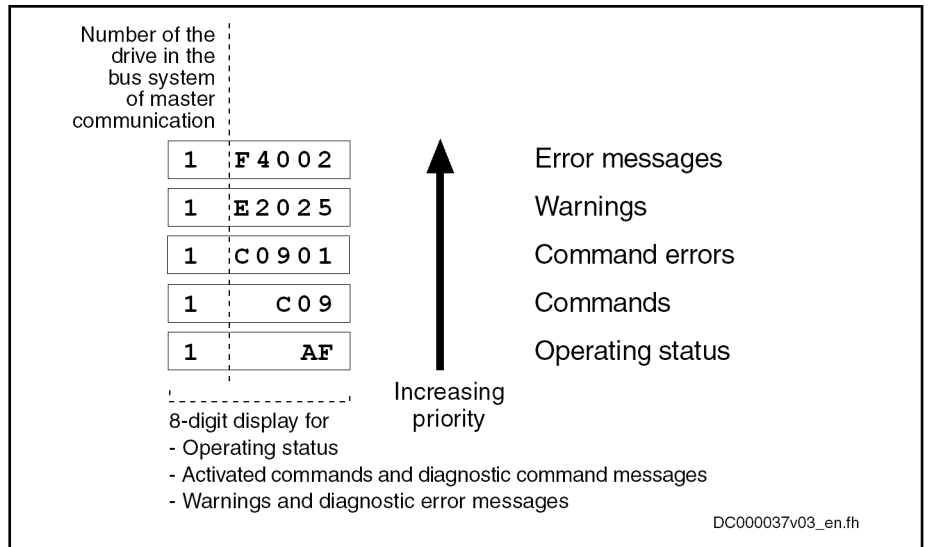

Fig.4-12: Priorities of displays (with sample displays)

With error messages, warnings and command errors, the diagnostic message text is displayed on the standard display in the form of a marquee text in the standard operating panel, in addition to the flashing diagnostic message number (see also Parameter Description "S-0-0095, Diagnostic message").

Activating extended display, Command menu, Service menu and Easy menu

The easy menu can always (without unlocking) be accessed by pressing the "Enter" key.

Simultaneously pressing the "Esc" and the "Enter" keys in the standard display (for 8 s when activated for the first time) accesses the extended menu.

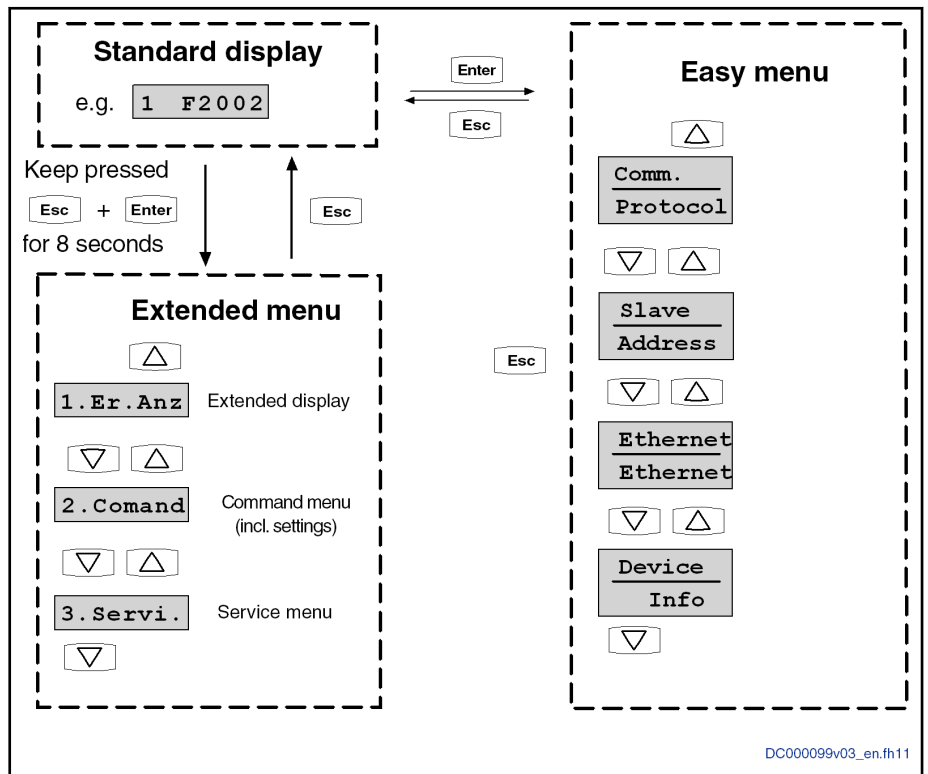

Fig.4-13: Activating the extended display, the command menu and the easy menu

Easy menu

Basics on Device Diagnosis

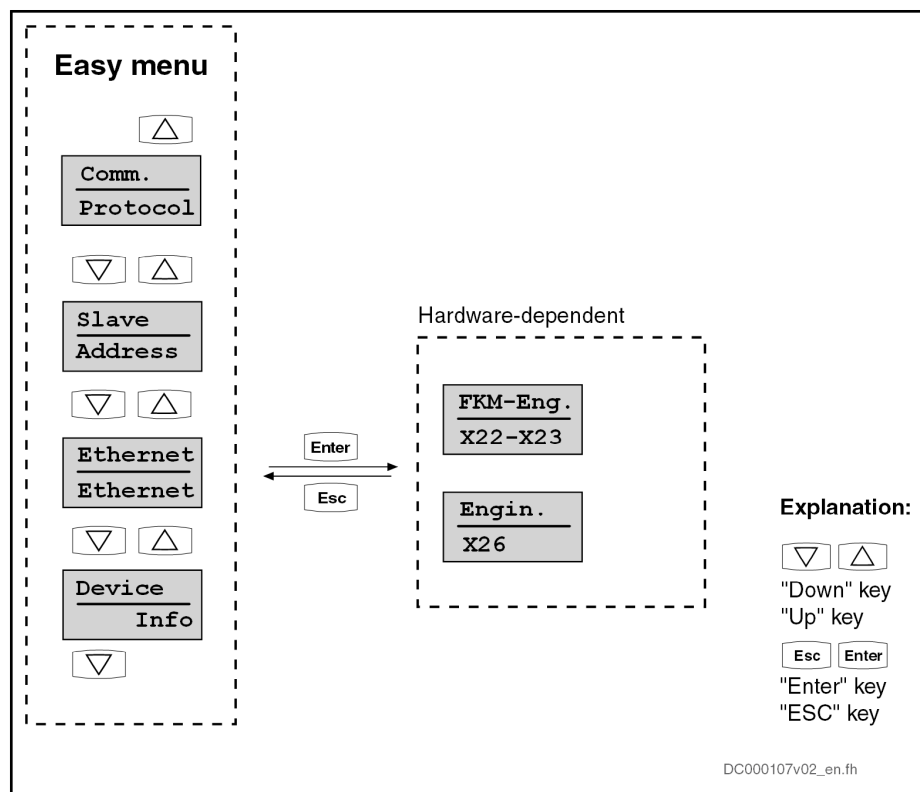

Fig.4-14: Easy menu

Control panel text:	Comment / note:
"Comm.____" "Protocol"	This submenu shows the current field bus protocol and can be changed, if required.
"Slave____" " _Address"	This submenu shows the current drive address. It can be changed, if required.
"Ethernet" "Ethernet"	In this menu the Ethernet connection can be viewed or set. The menu structure below "Ethernet" may vary, depending on the hardware (see "Easy menu" on page 53).
"Device____" " ____Info"	This submenu shows the information on the hardware to be used, e.g. firmware string (S-0-0030). No settings can be made in this submenu.

Basics on Device Diagnosis

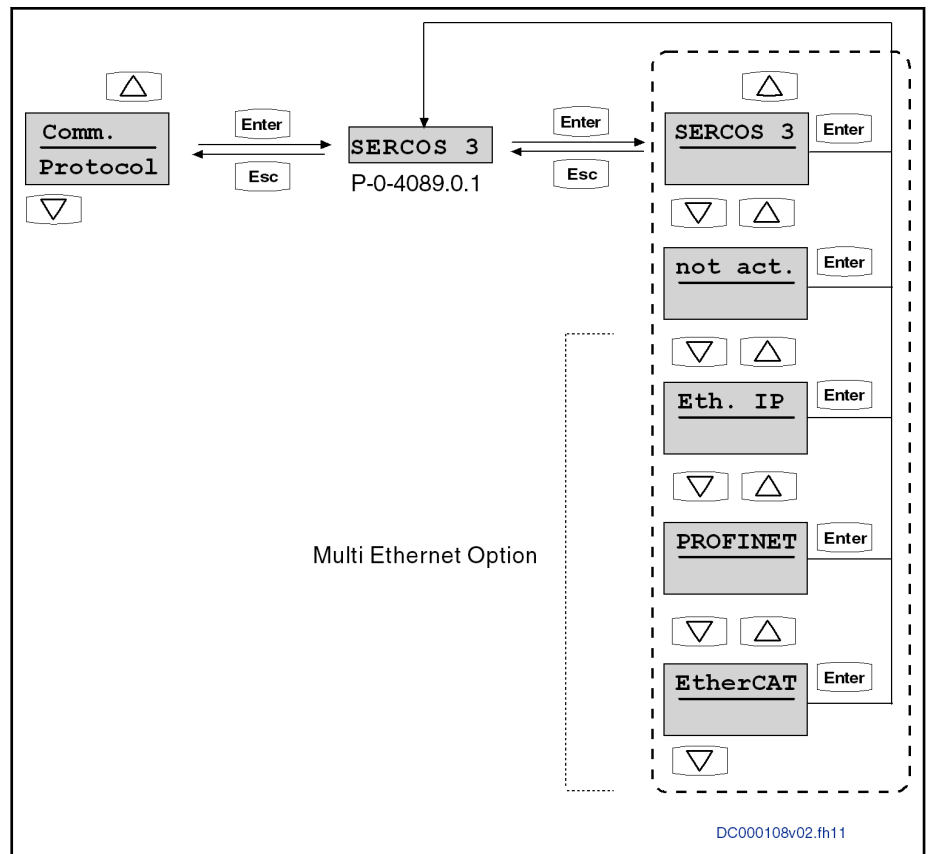

Fig.4-15: Submenu of "Comm.____" "Protocol"

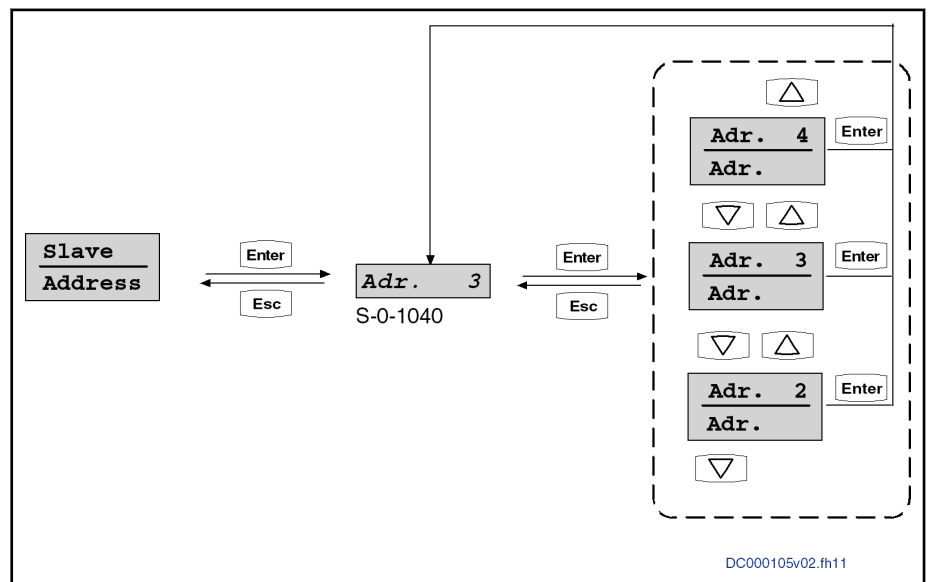

Fig.4-16: Submenu of "Slave____" "_Address"

Basics on Device Diagnosis

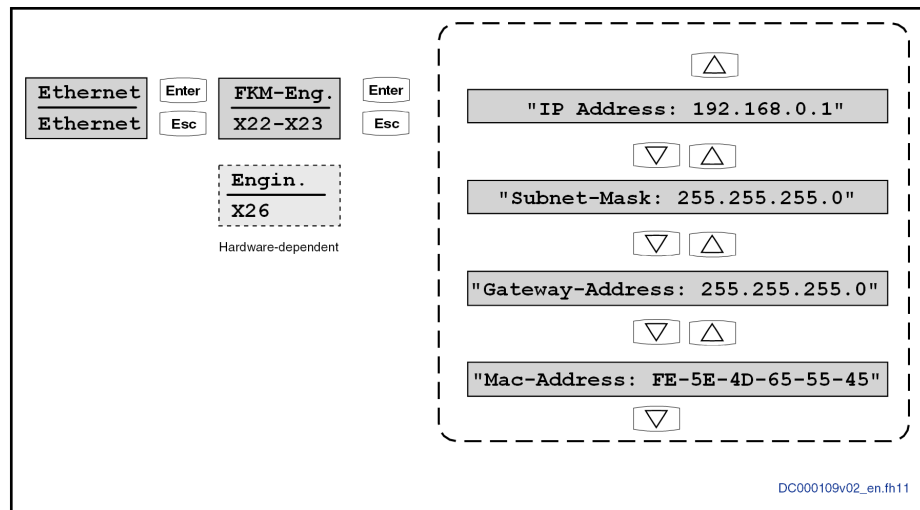

Fig.4-17: Submenu of "Ethernet" "Ethernet"

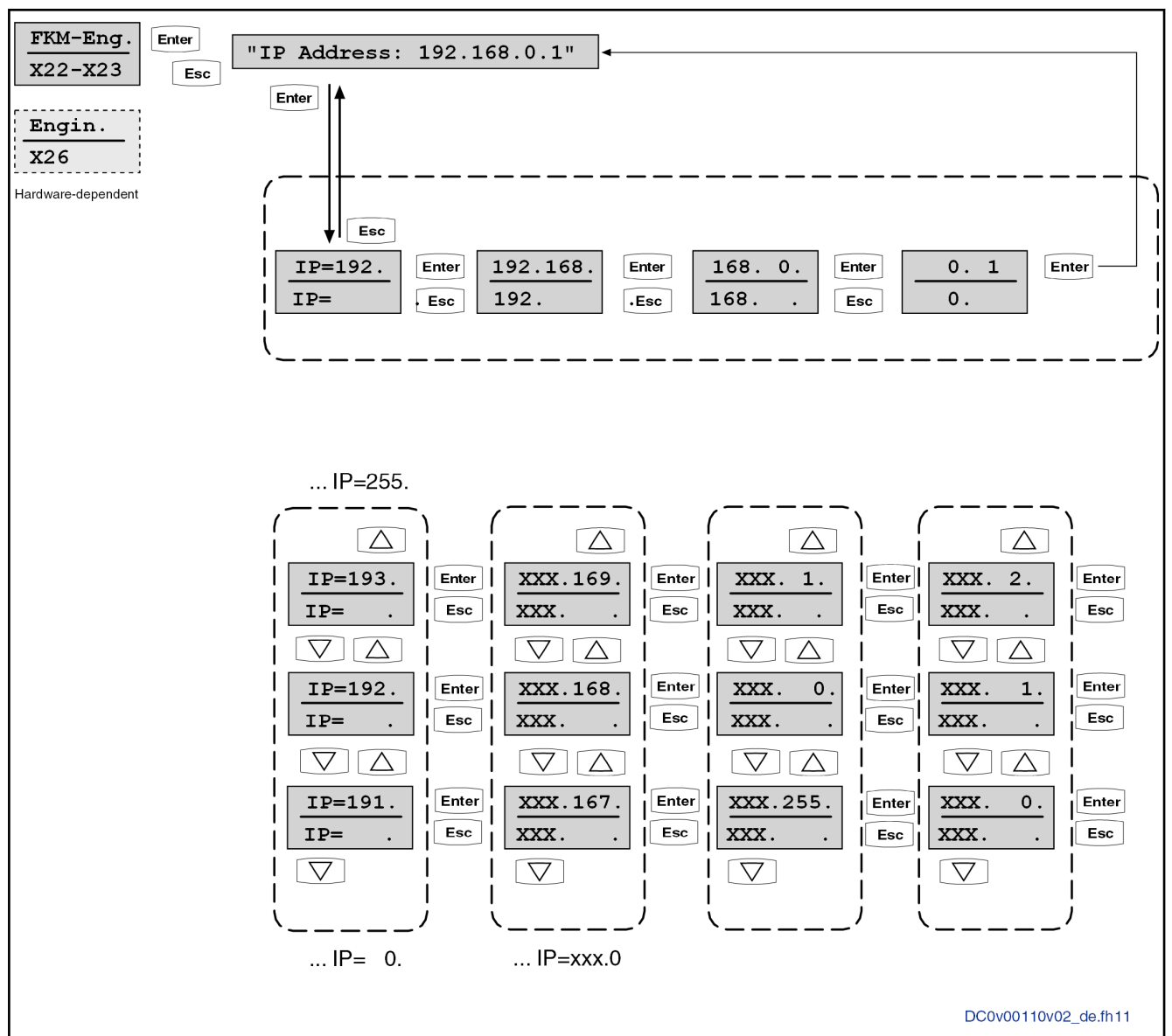
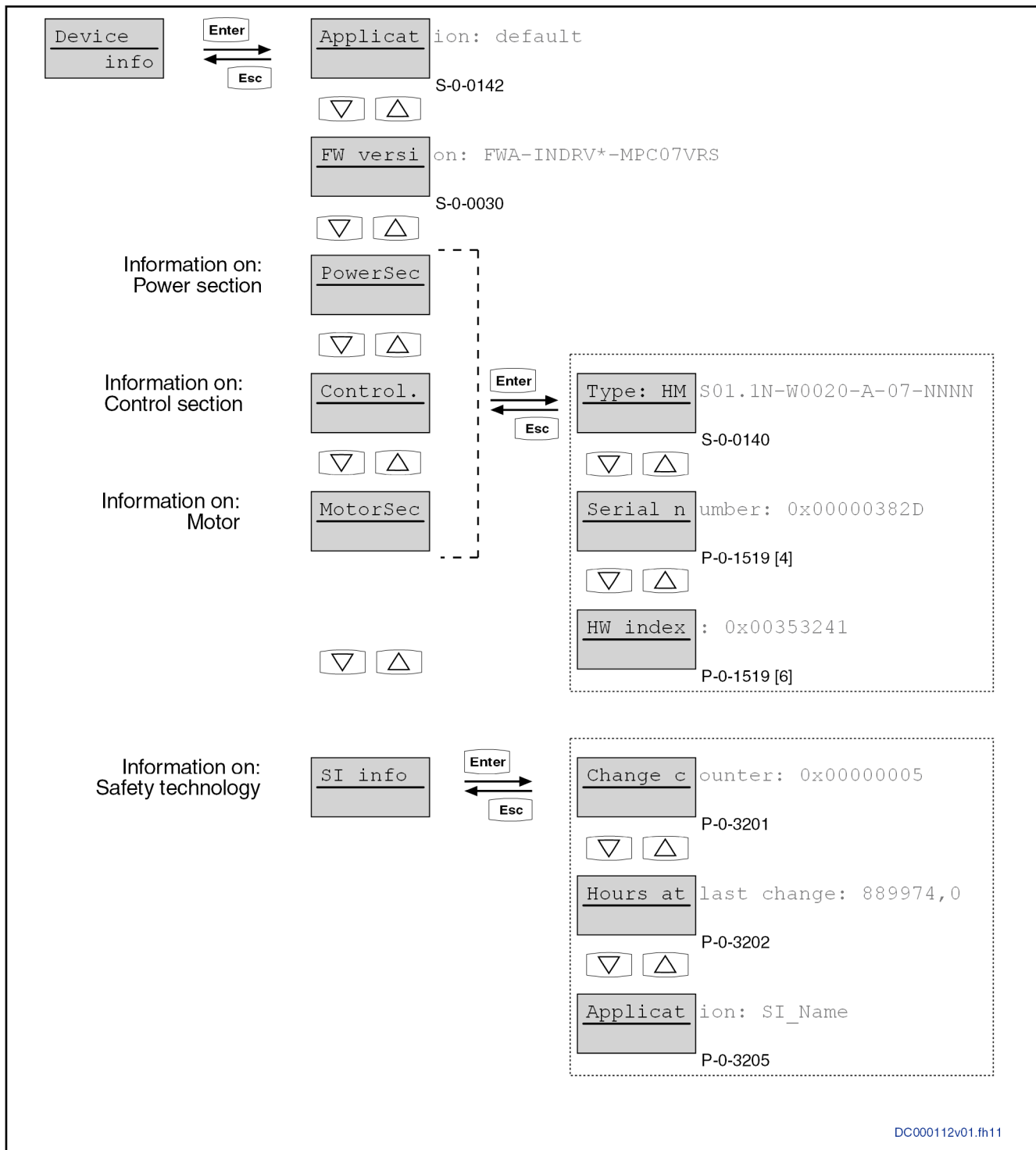

Fig. 4-18: Example for setting the IP address for "Master Communication Eng." "X22-X23"

Basics on Device Diagnosis



DC000112v01.fh11

Fig.4-19: Easy Menu, Structure Under "Device__" "___Info"

Assignment of the Entries in the "Device__" "___Info" Menu to the Parameters Used

Menu	Entry	Parameters used
-	Application	Text in "S-0-0142, Application type"
-	FW version	Text in "S-0-0030, Manufacturer version"

Basics on Device Diagnosis

Menu	Entry	Parameters used
PowerSec	Type	Text in "S-0-0140, Controller type"
	Serial number	"P-0-1519, Module code of power section", 5th element
	HW index	"P-0-1519, Module code of power section", 7th element
Control.	Type	Text in "P-0-1520, Control section type"
	Serial number	"P-0-1518, Module code of control section", 5th element
	HW index	"P-0-1518, Module code of control section", 7th element
MotorSec	Type	Text in "S-0-0141, Motor type"
	Serial number	"P-0-3000, Module code of motor, encoder memory", 5th element
	HW index	"P-0-3000, Module code of motor, encoder memory", 7th element
SI info	Change counter	"P-0-3201, Change counter of safety technology memory"
	Hours at last change	"P-0-3202, Operating hours at last change of memory"
	Application	"P-0-3205, Safety technology device identifier"

Extended display

By means of the extended displays, it is possible to additionally call up the contents of certain parameters:

- Error memory
- Diagnostic message memory
- Operating hours counter control section
- Operating hours counter power section
- Type designation of the firmware active in the device
- Safety technology code, change counter of safety technology and operating hours counter since last change (if safety technology option available)
- Diagnostic field bus message (P-0-4073)

Basics on Device Diagnosis

For more details on diagnostic messages, error messages and operating hours counters, see the respective sections of this document.

Command menu Starting from the extended display, the command menu is activated by pressing the "Up" key. This menu is used to enter different settings:

- Setting the drive address (drive number in the bus system of the master communication)
- Additional communication settings (IP address, gateway addresses and subnet mask)
- Activating the easy master communication mode "easy startup"
- Activating "S-0-0262, C07_x Load defaults procedure command" (load controller parameters or basic parameters)
- Switching the communication phases between operation mode (OM) and parameter mode (PM)

Basics on Device Diagnosis

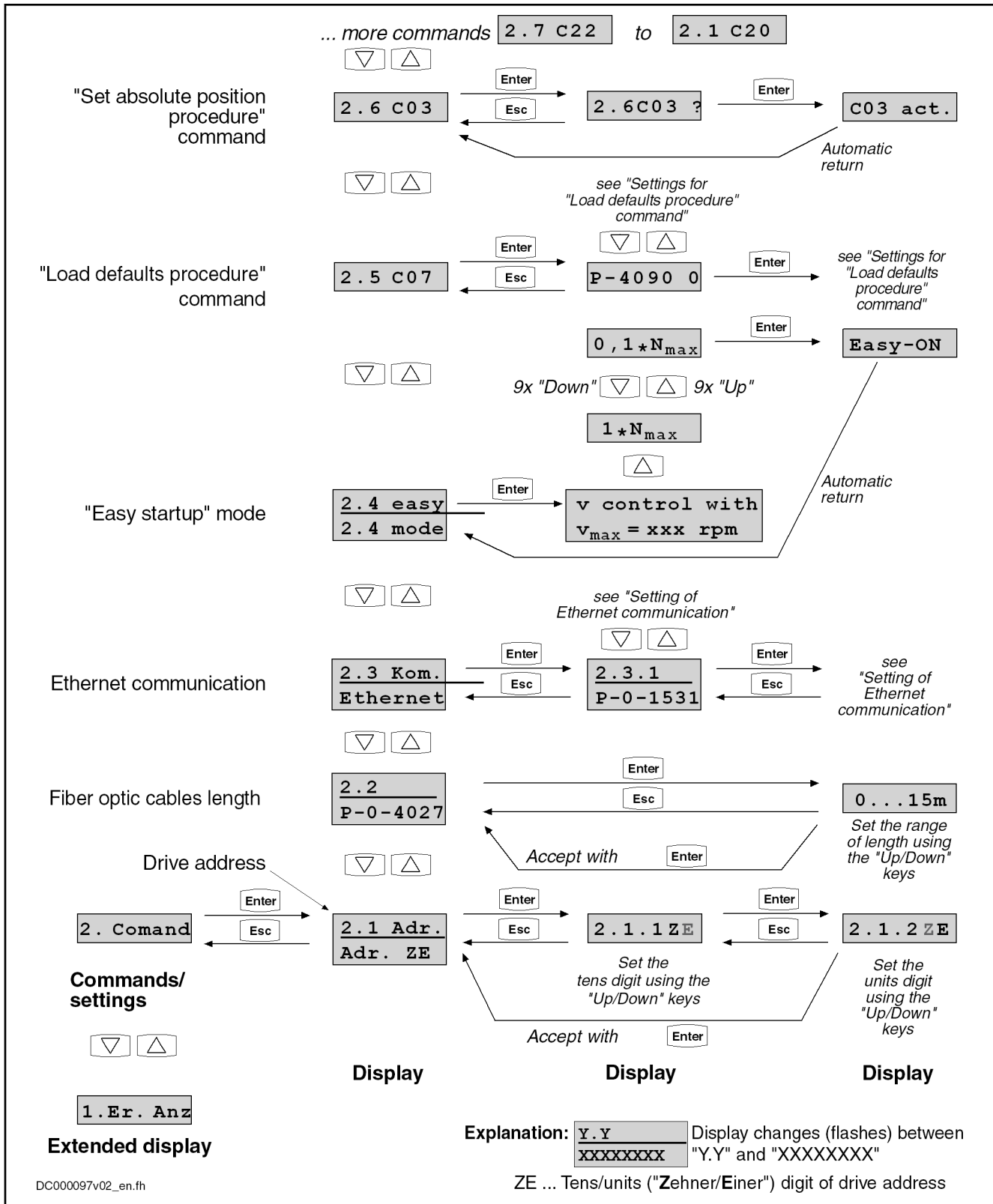

Fig.4-21: Activating commands/settings that can be accessed via the control panel (commands 2.1 to 2.6)

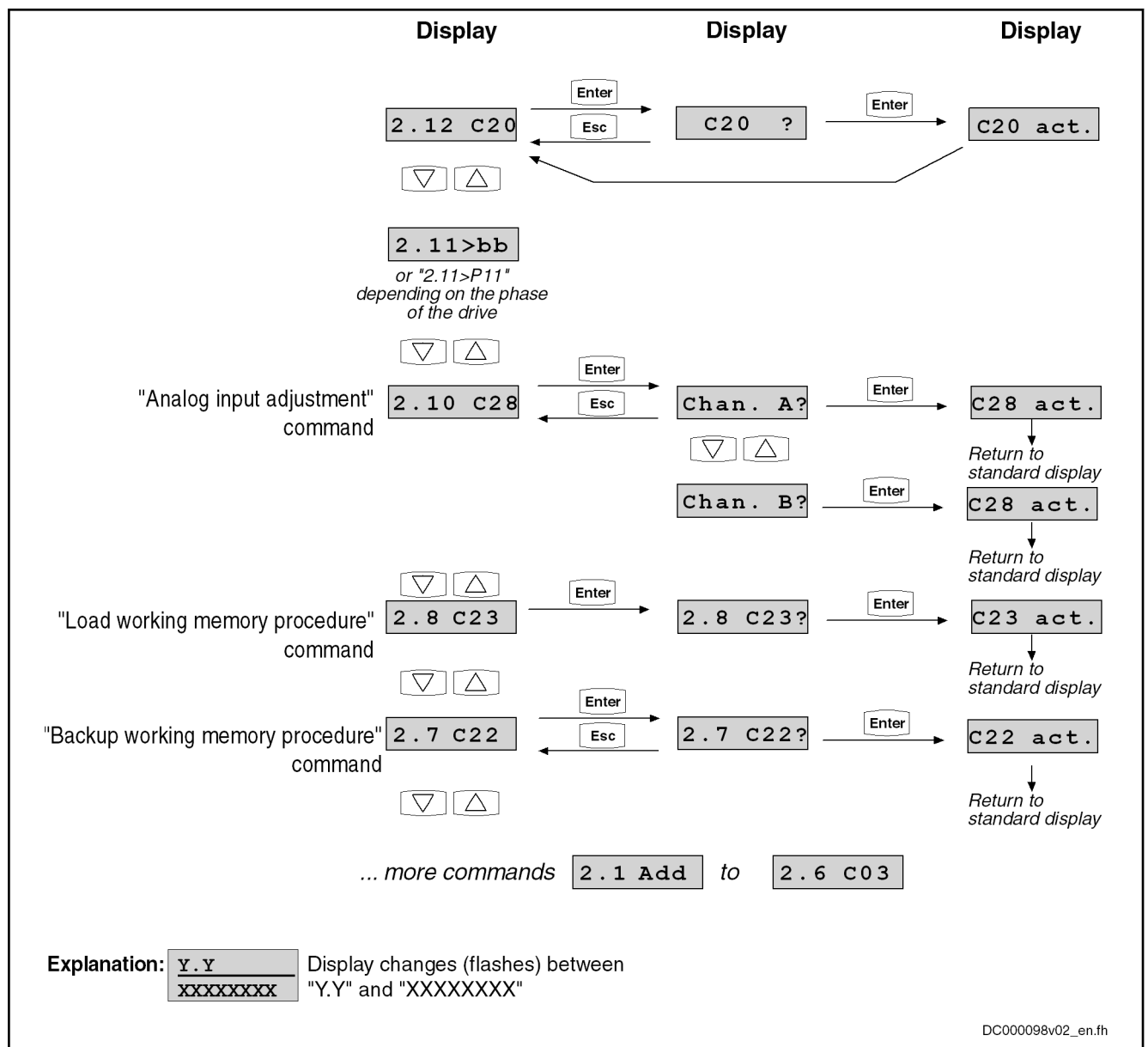

Fig. 4-22: Activating commands/settings that can be accessed via the control panel (commands 2.7 to 2.12)

Settings for the "Load Defaults Procedure" Command

The parameter "S-0-0262, C07_x Load defaults procedure command" can be activated via the standard control panel, too. Depending on the configuration in parameter "P-0-4090, Configuration for loading default values", different basic parameter sets are loaded internally. The following configurations in parameter P-0-4090 are possible via the standard control panel, the last two digits of the hexadecimal parameter value being displayed on the standard display:

- Loading motor-specific control loop parameter values → 0x0000
- Loading basic parameter values, without exception → 0x0001
- Loading basic parameter values, except for master communication parameters → 0x0011

Basics on Device Diagnosis



After the command C07_x has been executed, the parameter P-0-4090 is automatically reset to its default value (0x0000)!

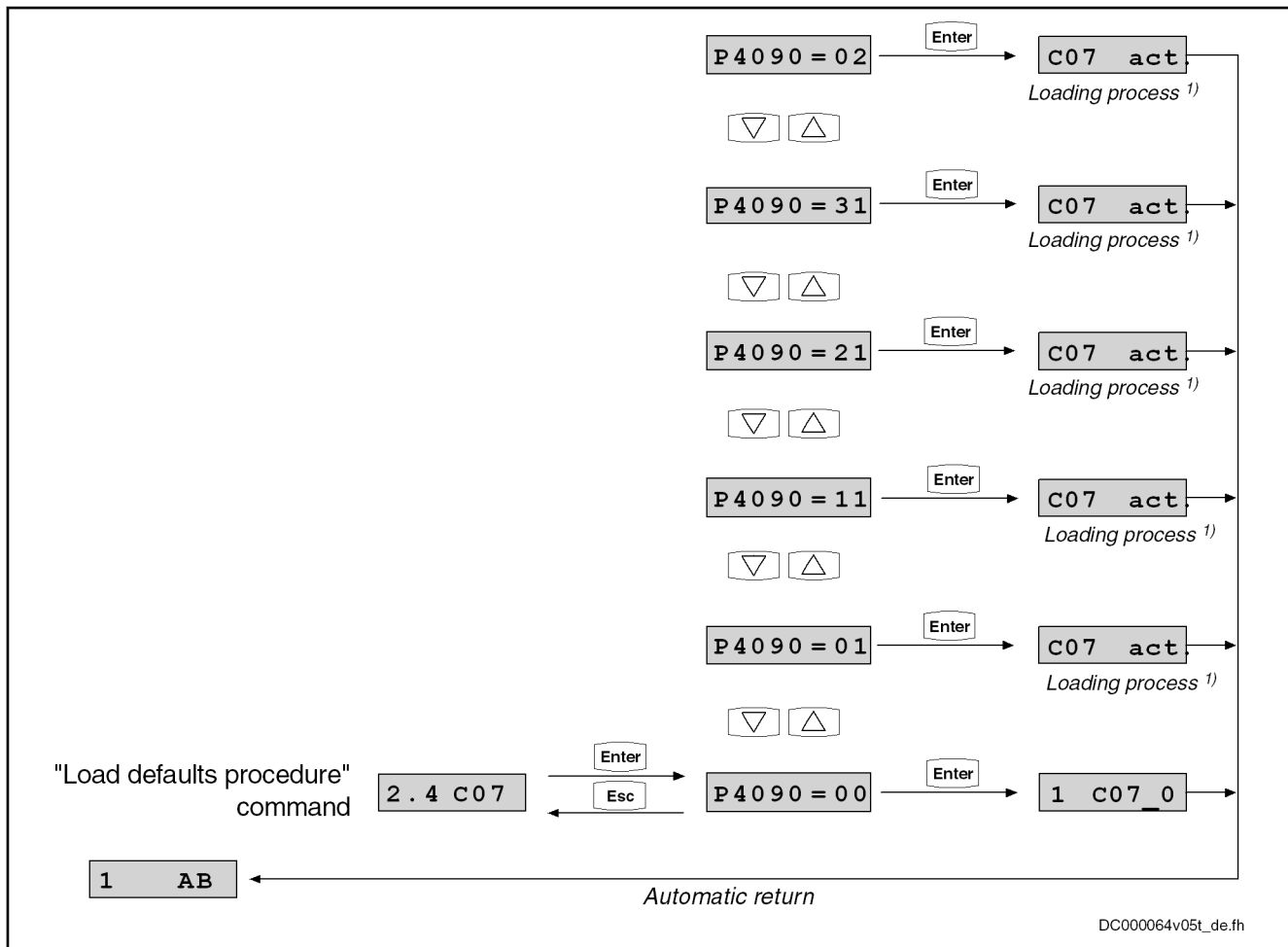

Fig.4-23: Setting parameter P-0-4090 for "load defaults procedure" via the standard control panel

Switching the communication phases

Switching the communication phases between operating mode (OM) and parameter mode (PM) via the control panel is possible with all master communications, except for sercos interface. With sercos interface, phase switch controlled via the control panel can only be carried out with "Easy startup" mode active!



In order to execute "C07_1 Load defaults procedure com. (load basic parameters)", the parameter mode (PM) has to be activated.

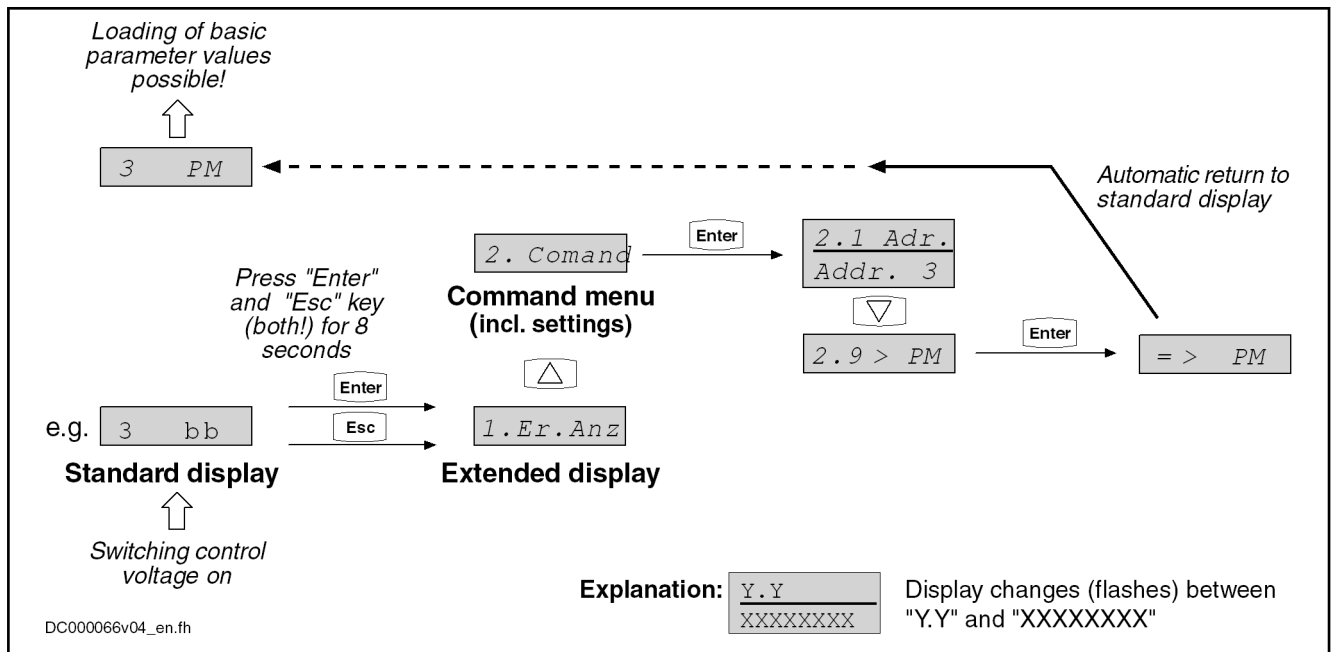

Fig.4-24: Activating parameter mode via the control panel

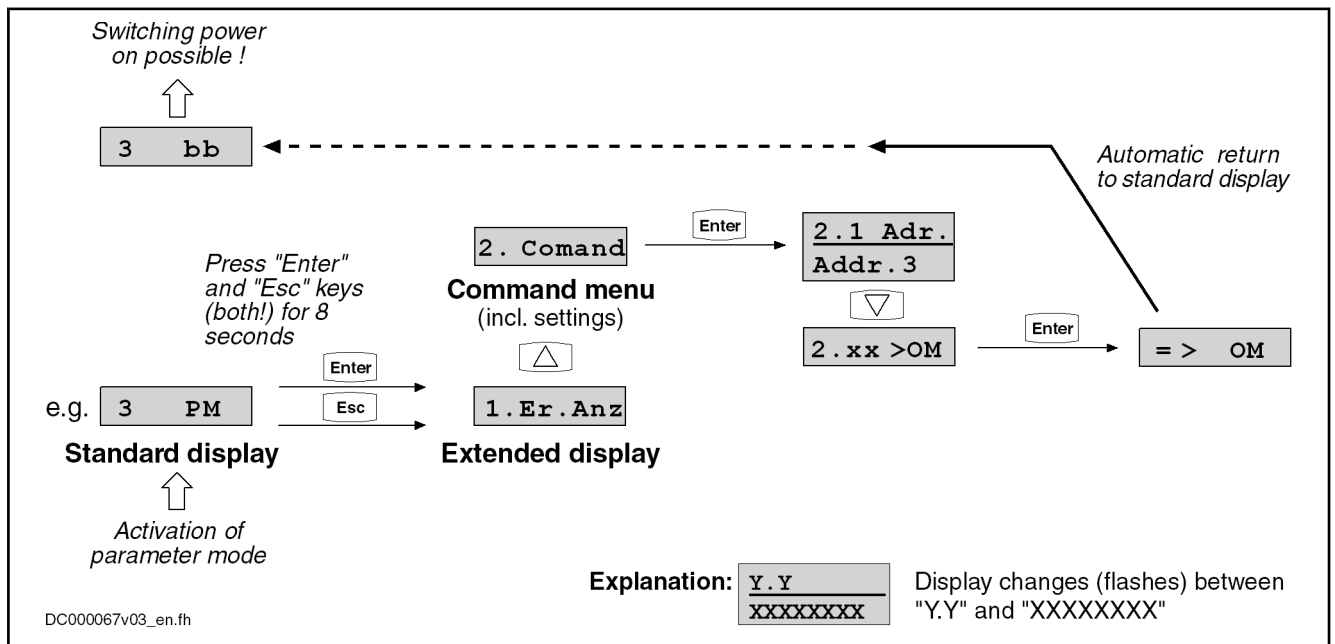

Fig.4-25: Switching back from parameter mode to operation mode via the control panel

Defining MMC storage mode

Parameter "P-0-4070, Parameter storage configuration" defines how the controller handles the (optional) MMC memory card. This setting can be defined directly via the command menu of the control panel (2.10). The following storage modes are possible for operating the MMC:

- MMC as programming module
- MMC as update medium
- MMC as backup medium

MMC as programming module

If the MMC has been defined as "programming module", all parameters are stored on the MMC. With an active controller, the MMC must be permanently plugged into the control section. If the controller is switched on without MMC

Basics on Device Diagnosis

MMC as update medium

or the MMC is removed from the active controller, the controller signals an error.

When the MMC has been defined as "update medium", the control section checks during the booting process whether an MMC was plugged in or not. The display asks whether the parameters are to be loaded from the MMC. If there is a newer firmware on the MMC, a request is issued as to whether this firmware is to be loaded. The parameters are not stored on the MMC, but in the onboard flash memory.

MMC as backup medium

When the MMC has been defined as "backup medium", it is used as a demand-dependent storage location for parameter settings. The parameter values are stored via a command, via the FTP server or file services (MLD).

When the MMC operation has been defined as "update medium" or as "back-up medium", it is **not** necessary to have the MMC permanently plugged into the control section. The MMC can be plugged in or removed with the drive active. Loading and storing parameter sets, however, is only possible with the MMC plugged in!



The options for using the MMC in the IndraDrive controller are described in detail in the section "MultiMediaCard (MMC)".

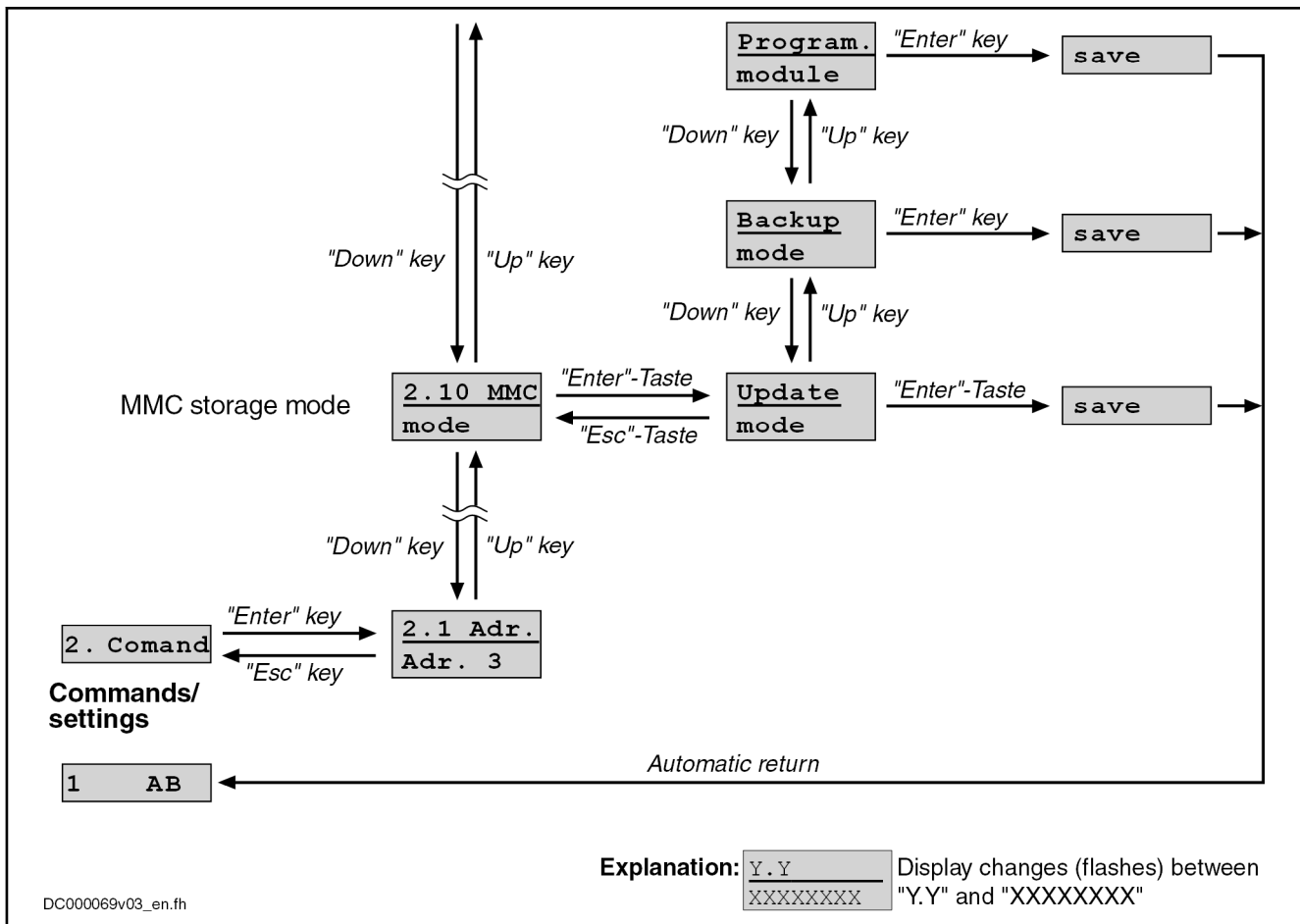

Fig.4-26: Setting the MMC Storage Mode With the Control Panel

Service menu

Starting from the command menu, activate the service menu by pressing the "Up" key. It supports the following actions:

Basics on Device Diagnosis

- Firmware update with previous saving of the parameter values on the internal memory (flash), if the optional memory (MMC) is the active memory (MMC as "programming module"). After the update, the parameter values can be loaded to the MMC again from the internal memory (flash).

Note: If the internal memory (flash) is the active storage medium ("hot plug" of the MMC), the parameter values are already available in the device and do not need to be saved before the MMC-based firmware update. In this case, pressing the "Enter" key with the display "Save data" has no effect!

- Replacement of device with saving of parameter values on MMC, if the internal memory (flash) is the active memory. After the device has been replaced, firmware and values of the drive parameters, as well as PLC retain data, can be loaded from this MMC to the replacement controller.

Note: If the control section has been equipped with the optional module "MDx", the retain data of the PLC is saved on the MMC in addition to the values of the drive parameters, when "Save data" is executed! When the MMC is the active memory, the drive parameters are not saved, because they have already been stored on the MMC, but the PLC data is stored on the MMC.

- Copying parameters:
 - Storing the parameter values and, if necessary, the PLC retain data from the device-internal, non-volatile memories (onboard flash and, if available, memory of optional module "MDx") on the MMC
 - Loading the parameter values stored on the MMC to the non-volatile memories of the controller

Basics on Device Diagnosis

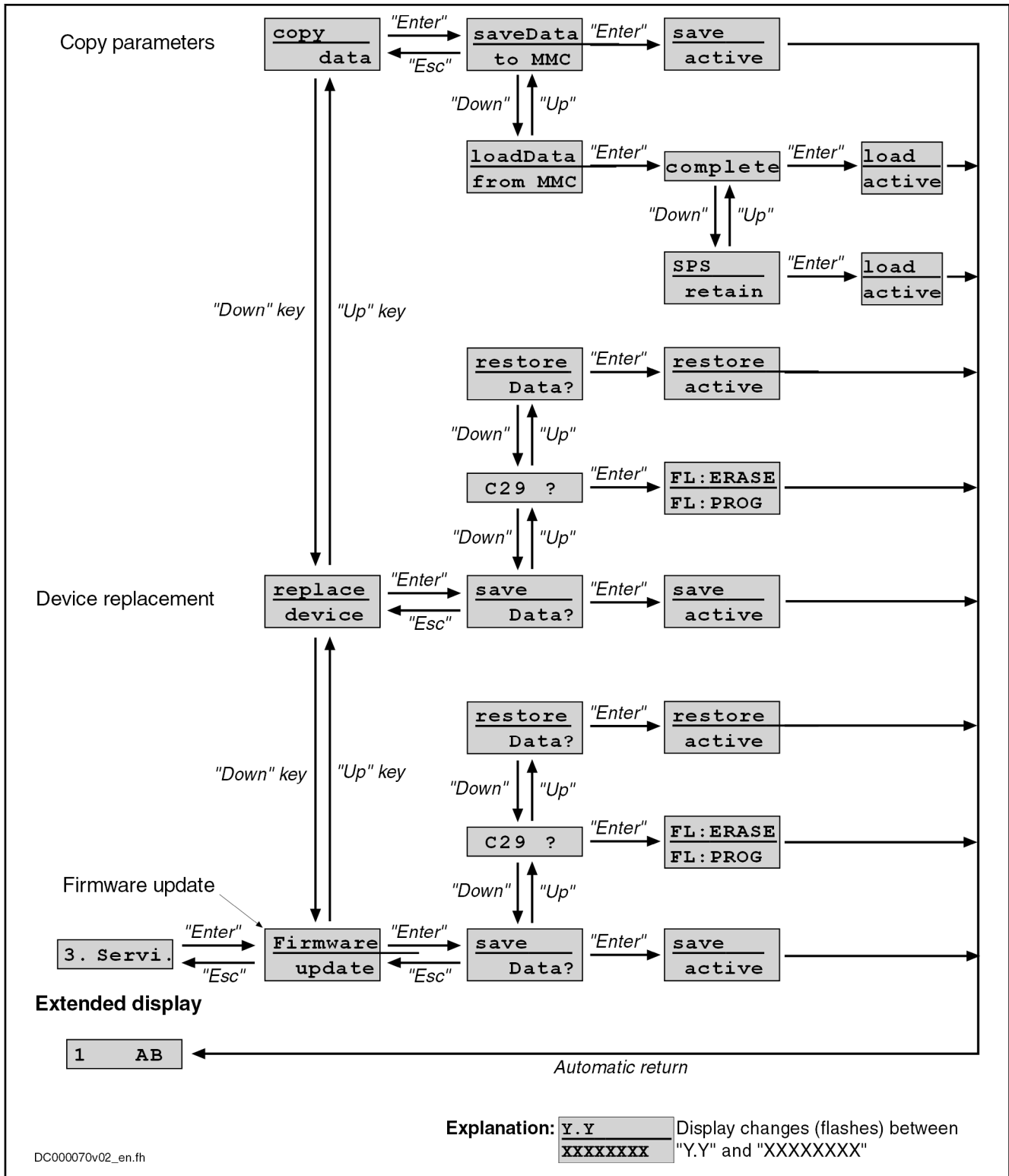

Fig.4-27: Activating the functions of the service menu

4.5 Terms, Basic Principles

4.5.1 Parameters

Communication between master and drive takes place, with a few exceptions, by means of parameters.

Parameters are used for:

- Determining the configuration
- Parameterizing the control loop
- Triggering and controlling drive functions and commands
- Transmitting command values and actual values (according to requirements, cyclically or acyclically)

All operating data are mapped to parameters!

The operating data stored in parameters can be identified by means of the IDN. They can be read and transferred, if required. The user write access to parameters depends on the properties of the respective parameter and the current communication phase. Specific parameter values (operating data) are checked for validity by the drive firmware.

4.5.2 Data Storage and Parameter Handling

Data Memory Several non-volatile data memories are available in an IndraDrive device:

- In the controller
- In the motor encoder (depending on motor type)
- As a MultiMediaCard (MMC), optional

In addition, a volatile data memory (working memory) is available in the controller.

Condition as Supplied Condition as supplied of the Rexroth drive components:

- The controller memory contains the drive firmware and the controller-specific parameter values.
- The motor encoder memory contains the encoder-specific and, depending on the motor type, the motor-specific parameter values.
- The MMC contains the drive firmware and the basic parameter sets.

Storing the Application-Specific Parameter Values The application-specific parameter values are stored in the controller. Due to the limited number of writing cycles of non-volatile storage media, application-specific parameter values can be stored in the working memory (volatile memory), too.

Saving Parameter Values Saving application-specific parameter values is required in the following cases:

- After initial commissioning of the machine axis or the motor
- Before replacing the controller for servicing (if possible)

Application-specific parameter values can be saved via:

- MMC → Copying the parameter values by command
- "IndraWorks Ds/D/MLD" commissioning tool → Saving the parameter values on external data carrier
- Control master → Saving the parameter values on master-side data carrier

Parameter IDN Lists The drive supports master-side saving of parameter values by listing parameter identification numbers (IDNs). Using these lists guarantees complete stor-

Basics on Device Diagnosis

age of the application-specific parameter values. It is also possible to determine IDN lists defined by the customer.

Loading Parameter Values

Loading parameter values is required in the following cases:

- Initial commissioning of the motor (loading basic parameter values and motor-specific parameter values)
- Serial commissioning of machine axes at series machines (loading the values saved after initial commissioning)
- Reestablishing a defined initial status (repeated loading of the values saved after initial commissioning)
- Replacing the controller for servicing (loading the current parameter values saved before servicing)

Options for loading parameter values to the controller:

- Motor encoder data memory → Loading the parameter values by command or via the control panel during initial motor commissioning
- MMC → Loading the parameter values by command
- "IndraWorks Ds/D/MLD" commissioning tool → Loading the parameter values from external data carrier
- Control master → Loading the parameter values from master-side data carrier

Checksum of Parameter Values

By means of checksum comparison, the control master can determine whether the values of the application-specific parameter values currently active in the drive correspond to the values saved on the master side.

4.5.3 Password

IndraDrive controllers provide the possibility to protect parameter values against accidental or unauthorized change by means of a password. With regard to write protection, there are 3 groups of parameters that can be written:

- Parameters that are write-protected as a standard, such as motor parameters, hardware code parameters, encoder parameters, error memory, etc. ("administration parameters"). The values of these parameters guarantee the correct function and performance of the drive.
- Parameters the customer can combine in groups and protect them with a so-called customer password. This allows protecting parameter values that are used for adjusting the drive to the axis, after having determined them.
- All other parameters that can be written and are not contained in the above-mentioned groups. They are not write-protected.

Types of Passwords

The drive firmware allows activating and deactivating the write protection for parameter values by means of three hierarchically different passwords:

- **Customer Password**
The parameter values of a parameter group combined by the customer can be protected.
- **Control Password**
Parameters protected by a customer password can be written; "administration parameters" remain write-protected.
- **Master Password**
All parameters that can be written, including "administration parameters" and parameters protected by a customer password, can be changed.

4.5.4 Commands

Commands are used to activate and control complex functions or monitoring features in the drive. The higher-level master can start, interrupt or clear commands.

Each command is assigned to a parameter by means of which the execution of the command can be controlled. During the execution of the command the display of the control panel reads "Cx", "C" representing the diagnostic command message and "x" representing the number of the command.



Each command that was started must be actively cleared again.

All commands available in the drive are stored in the parameter "S-0-0025, IDN-list of all procedure commands".

Types of Commands

We distinguish 3 different types of commands:

- **Drive control commands**
 - Can cause automatic drive motion
 - Can only be started when drive enable has been set
 - Deactivate the active operation mode during its execution
- **Monitor commands**
 - Activate or deactivate monitorings or functions in the drive
- **Administration commands**
 - Carry out administration tasks
 - Cannot be interrupted

See also section "Command Processing"

4.5.5 Operation Modes

The selection of operation modes defines which command values will be processed in which way, in order to lead to the desired drive motion. The operation mode does not determine how these command values are transmitted from the master to the slave.

One of the eight (for SERCOS) operation modes that are defined in parameters is always active if the following conditions have been fulfilled:

- Control section and power section are ready for operation
- Drive enable signal sees a positive edge
- Drive follows command value input
- "Drive Halt" function has not been activated
- No drive control command is active
- No error reaction is carried out

The display of the control panel reads "AF" when an operation mode was activated.



All implemented operation modes are stored in the parameter "S-0-0292, List of supported operation modes".

See also chapter "Operation Modes"

4.5.6 Warnings

Depending on the active operation mode and the parameter settings, many monitoring functions are carried out. If a state is detected that still allows correct operation but in case this state persists will cause an error to occur and therefore cause the drive to be automatically switched off, the drive firmware generates a warning message.



Warnings do not cause automatic shutdown (exception: fatal warnings).

Warning Classes

Warnings are classified in different warning classes which determine whether the drive, when the warning is generated, carries out an automatic reaction or not.



The warning class can be recognized by the diagnostic message.

We distinguish the following warning classes:

- **Without** drive reaction → Diagnostic message number **E2xxx**, **E3xxx**, **E4xxx**
- **With** drive reaction → Diagnostic message number **E8xxx**



Warnings cannot be cleared. They persist until the condition that activated the warning is no longer fulfilled.

4.5.7 Errors

Depending on the active operation mode and the parameter settings, many monitoring functions are carried out. If a state is detected that affects or prevents correct operation, the drive firmware generates an error message.

Error Classes

Errors are assigned to different error classes which are distinguished by different error reactions of the drive.



The error class can be recognized by the diagnostic message number.

Diagnostic message number	Error class
F2xxx	Non-fatal error
F3xxx	Non-fatal safety technology error
F4xxx	Interface error
F6xxx	Travel range error
F7xxx	Safety technology error
F8xxx	Fatal error
F9xxx	Fatal system error
E-xxxx	Fatal system error "Processor exception"

Fig. 4-28: Overview of Error Classes



Apart from the mentioned error classes that can occur during operation, errors can occur when the devices are booted and during firmware download. These errors are not displayed at the control panel with a diagnostic message number of the "Fxxx" pattern, but with a short text. Booting and firmware download errors are described in the separate documentation "Troubleshooting Guide" (description of diagnostic messages).

Error Reactions of the Drive

If the drive controller is in control and an error status is detected, the execution of a drive error reaction is automatically started. The diagnostic message number "Fxxx" flashes on the display of the control panel.

The drive reaction in the case of interface errors and non-fatal errors is determined in parameter "P-0-0119, Best possible deceleration". At the end of each error reaction, the drive goes torque-free.

See also "Error Reactions"

Clearing an Error Message

Error messages are not cleared automatically, but by means of a procedure depending on the severity of the error, see separate documentation "Troubleshooting Guide" (description of diagnostic messages).

If the error status persists, the error message is immediately generated again.

Clearing Error Messages when Drive Enable was set

If a drive error occurs while operating with drive enable having been set, the drive carries out an error reaction. The drive automatically deactivates itself at the end of each error reaction; in other words, the output stage is switched off and the drive switches from an energized to a de-energized state.

To reactivate the drive:

- Clear the error message and
- Input a positive edge for drive enable again

Error Memory

The diagnostic message numbers of occurring errors are written to an error memory. This memory contains the diagnostic message numbers of the last 50 errors that occurred and the time when they occurred. Errors caused by a shutdown of the control voltage (e.g. "F8070 +24Volt DC error") are not stored in the error memory.

The diagnostic message numbers in the error memory are mapped to the parameter "P-0-0192, Error memory of diagnostic numbers" and can be displayed by means of the control panel. By means of the "IndraWorks Ds/D/MLD" commissioning tool, it is possible to display the diagnostic message numbers and the respective times at which the errors occurred.

5 Operating States

5.1 General Information

The possible operating states are listed below in alphabetical order. The operating states are displayed on the control panel of the device.

5.2 Ab / VM Bb

"Drive ready"

See also: **A0012 Control and power sections ready for operation**

5.3 AC

See also: **A4000 Automatic drive check and adjustment**

5.4 AE

See also: **A4001 Drive deceleration to standstill**

5.5 AF

"Drive enable"

Depending on the operation mode used, you can find a detailed description of the "AF" display under the respective diagnostic status message.

5.6 AH

"Drive Halt"

See also: **A0010 Drive HALT**

5.7 AR

"Automatic drive reaction"

The drive can carry out an automatic drive reaction depending on the drive function used.

As of firmware MPx05, the function "quick stop via probe input" (A0403 Quick stop with probe detection is active) activates the operating status "AR" (see also Functional Description of firmware "Quick Stop via Probe Input").

5.8 AS

See also: **A0011 Starting lockout active**

5.9 ASP

See also: **A0014 Drive interlock active**

5.10 AU

See also: **A4002 Drive in automatic mode**

5.11 bb / VM bb

"Ready for operation"

Operating States

See also: **A0013 Ready for power on**

5.12 charg / VM charg

See also: **A0503 DC bus charging active**

5.13 CM

See also: **A4003 Setting-up mode is active**

5.14 OM

See also: **A0051 Operating mode**

5.15 P0 / VM P0

"Phase 0" (only with SERCOS master communication)

See also: **A0000 Communication phase 0**

5.16 P-1

"Phase -1"

See also: **A0009 Automatic baud rate detection for SERCOS interface**

5.17 P1 / VM P1

"Phase 1"

See also: **A0001 Communication phase 1**

5.18 P2 / VM P2

"Phase 2"

See also: **A0002 Communication phase 2**

5.19 P3 / VM P3

"Phase 3"

See also: **A0003 Communication phase 3**

5.20 PM

See also: **A0050 Parameterization level 1 active**

5.21 PL

"Parameter load with basic values"

See also: **F2009 PL Load parameter default values**

5.22 RL

See also: **F2008 RL The motor type has changed.**

5.23 SBB

See also: **A0017 Special mode motion active**

5.24 SBB1

See also: **A0018**

5.25 SBB2

See also: **A0019**

5.26 SBB3

See also: **A0020**

5.27 SBB4

See also: **A0021**

5.28 SBH

See also: **A0016**

5.29 SH

See also: **A0015**

5.30 SMM1

See also: **A0018 Special mode safe motion 1 active**

5.31 SMM2

See also: **A0019 Special mode safe motion 2 active**

5.32 SMM3

See also: **A0020 Special mode safe motion 3 active**

5.33 SMM4

See also: **A0021 Special mode safe motion 4 active**

5.34 SS1

See also: **A0015 Safe stop 1 active**

5.35 SS1 ES

See also: **A0014 Safe stop 1 (Emergency stop) active**

5.36 SS2

See also: **A0016 Safe stop 2 active**

5.37 STO

See also: **A0011 Safe torque off active**

Operating States

5.38 VM Lb

See also: **A0500 Supply module in voltage control**

5.39 VM LB

See also: **A0502 Supply module in operation**

5.40 VM ZKS

See also: **A0520 DC bus quick discharge active**

6 Diagnostic Messages when Booting the Devices

6.1 Devices With Valid Firmware

When a valid firmware is available in the control section, the texts

BOOT 1.1

BOOT 1.2

BOOT 1.3

are displayed on the control section display of the devices after the control voltage is switched on ("booting"). The controller first goes through the booting phases in which the basic initialization of the processor takes place.

In the following booting phases, the basic initialization of the hardware configuration, the peripherals, the parameters, the master communication, etc. takes place:

BOOT 2.1

BOOT 2.2

...

BOOT 2.9

In the final booting phases, the initialization results are checked.

BOOT 3.0

BOOT 3.1

If errors have occurred during initialization, they are output via the display. If not, the device can be operated.

6.2 Devices Without Valid Firmware

In case the device does not detect any valid firmware, neither in the non-volatile memory (flash) nor on the MultiMediaCard (MMC), the so-called "loader" is started. The "loader" is an auxiliary program used to load firmware to the flash memory. When the "loader" is activated, the controller goes through several initialization phases:

LOAD 1

LOAD 2

LOAD 3

LOAD 4

The `LOADER` display signals indicating that the auxiliary program for loading ("download") firmware is ready for operation.

In this status, the controller is not ready for normal operation; it is first necessary to load valid firmware.



Firmware replacement is possible in this state with IndraWorks (menu item **Tools** ▶ **Drive** ▶ **Firmware Management**) via the serial interface or the MMC.

6.3 Error Messages When Booting the Devices

6.3.1 PLC ?

Brief Description: PLC start dialog

Diagnostic Messages when Booting the Devices

Before "Boot 2.9" was displayed on the control panel the buttons "ESC" and "ENTER" had been simultaneously pressed and kept pressed on the control panel.

As the functional package "Motion Logic" (drive PLC and technology functions) has been enabled, the display reads "PLC ?". The automatic start of a PLC boot project was prevented.

By pressing the arrow buttons (arrow down or arrow up) the display changes between "Run PLC" and "Stop PLC".

6.3.2 Stop PLC

Brief Description: Do not start PLC after booting

Pressing the "ENTER" button on the control panel prevents the start of a PLC boot project.

6.3.3 Run PLC

Brief Description: Start PLC after booting

When the "ENTER" button is pressed on the control panel, the drive PLC and a possibly available boot project are started after the booting process.

6.3.4 Load New Safety ?

Brief Description: Query: Load safety technology parameters from MMC?



MMC plugged or changed indicates that the control section was replaced. In this case it is possible to activate safety technology with the parameter file backed up during safety technology commissioning, but without repeated safety technology commissioning (see "Replacing the Control Section").

Cause	Remedy
<p>Drive controller is equipped with optional safety technology module and active, non-volatile memory ("P-0-4065, Non-volatile memory active") has changed while controller was switched off, because</p> <ul style="list-style-type: none"> • MMC was plugged (before switching off, device-internal memory was active) or • MultiMediaCard (MMC) was replaced (different MMC was active) or • MMC was removed (before switching off, MMC was active) 	<p>Confirm diagnostic message with "ENTER" in order to initiate loading of safety technology parameters from parameter file of MMC.</p> <p>ATTENTION! Safety technology parameters already existing on control section will get lost.</p> <p>In parameter mode, parameters are first accepted in safety technology channel 1. They are only accepted by channel 2 when switching to operating mode, without restart in the meantime. If "P-0-3206, Safety technology password" in loaded parameter file is unequal default value "INDRASAVE", safety technology has been activated. For further steps see "Replacing the Control Section"</p> <p>– or –</p> <p>Confirm diagnostic message with "ESC" and safety technology parameters won't be accepted</p>

6.3.5 No IDN on MMC !

Brief Description: MMC was not formatted correctly

Diagnostic Messages when Booting the Devices

Cause	Remedy
Content of MMC is incorrect. Parameter (*.pbf) or retain file (*.rbf) is missing	Switch drive off and plug in MMC with correct content
MMC was not formatted correctly	Switch drive off and plug in appropriate MMC – or – Switch drive off and format MMC again on PC and plug it in again

6.3.6 Load Par from MMC

Brief Description: MMC plugged, changed or removed => different parameter file

Cause	Remedy
Active, non-volatile memory ("P-0-4065, Non-volatile memory active") has changed while drive was switched off, because <ul style="list-style-type: none"> an MMC was plugged (before switching drive off, device-internal memory had been active) or MultiMediaCard (MMC) was replaced (other MMC was active) or MMC was removed (before switching drive off, MMC was active) 	Confirm diagnostic message with "ENTER" and start loading of new parameters – or – Switch drive off and insert active, non-volatile memory again that was used before drive was switched off, by either plugging in MMC / old MMC or removing MMC again (device-internal memory was active). Then switch drive on again

6.3.7 End C29

Brief Description: Command C29 successfully completed

The command "C2900 Command Firmware update from MMC" was successfully completed. The firmware was copied from the MultiMediaCard (MMC) to the drive-internal memory.

6.3.8 new MMC activate

Brief Description: MMC is active memory

"Programming module mode" was set in "P-0-4070, Parameter storage configuration". The MMC check during the booting process showed that this MMC had not been operated at the last switch-off [the CID (card IDN) of the MMC has changed].

Cause	Remedy
MMC was replaced with device switched off	To activate plugged MMC as programming module, press <Enter> on control panel - or - To ignore plugged MMC and load parameters from on-board memory, press <ESC> on control panel. As "programming module mode" was set in "P-0-4070, Parameter storage configuration", error message "F2120 MMC: defective or missing, replace" is displayed after booting process.

6.3.9 MMC not correct!

Brief Description: MMC incorrectly formatted

Diagnostic Messages when Booting the Devices

Cause	Remedy
MMC was not formatted correctly	Switch drive off and plug in appropriate MMC – or – Switch drive off and format MMC again on PC and plug it in again
No IBF file or several IBF files on MMC	Switch drive off and plug in appropriate MMC
No appropriate parameter file and retain data file on MMC	Switch drive off and plug in appropriate MMC

6.3.10 IBF not correct!

Brief Description: Content of IBF file not correct

Cause	Remedy
IBF file on MMC is not okay	Switch drive off and install MMC with appropriate IBF file in drive – or – On PC copy appropriate IBF file to MMC

6.3.11 Firmware update ?

Brief Description: Different firmware in device and on MMC

During the booting process with the MMC plugged in, a check is run by means of the release version to find out whether the firmware (FW) on the flash is identical to the one on the MMC.

Cause	Remedy
Check showed that firmware on flash and on MMC are not identical	Switch drive off and install MMC in drive with the same release version as on flash – or – Confirm diagnostic message with "ENTER" and start firmware update

6.3.12 Update Error !

Brief Description: Firmware update error during booting process

Cause	Remedy
Firmware not updated properly	Reboot device and start firmware update - or - Switch off drive, remove MMC and update firmware using "IndraWorks" on the PC

6.3.13 XXX Upd

Brief Description: Copy firmware or logicware XXX from MMC to ET

During the `xxx Upd` diagnostic messages, ("XXX" is a placeholder for the Logicware or the firmware), the Logicware or the firmware of the MMC is copied to the SPI-Flash of the optional module "ET" (multi-Ethernet).

During the copying processes that can take up to 90 seconds, the following diagnostic messages are displayed:

Diagnostic Messages when Booting the Devices

- EPL Upd: Ethernet/IP-Logicware is copied
- EPF Upd: Ethernet/IP firmware is copied
- ECL Upd: EtherCat-Logicware is copied
- S3L Upd: sercos Logicware is copied



Please wait until the copy processes are completed. If the drive is switched off during copying, the copy processes are restarted the next time the drive is booted.

6.3.14 ActLW Up

Brief Description: Copies active logicware within ET to address 0

The selected master communication protocol (P-0-4089.0.1) was changed after the last restart of the drive. The logicware required for the master communication protocol is copied within the optional module "ET" (Multi-Ethernet).

This diagnostic message is displayed for the duration of the copy process (approx. 10 seconds).

6.3.15 E FIP nf

Brief Description: ET error: Flash Info Page not found

At the first access to the SPI flash of the optional module "ET" (Multi-Ethernet), there is an attempt to read the "Flash Info Page" (FIP). An error occurred during this access.

Cause	Remedy
SPI flash of optional module "ET" is empty, was incorrectly written or, if drive worked correctly before, was overwritten - or - Optional module "ET" is defective	Switch drive controller off and then on again. If error occurs again, please contact our service department

6.3.16 E FIP CS

Brief Description: ET error: Flash Info Page checksum incorrect

The "Flash Info Page" (FIP) was found; this means that the optional module "ET" (Multi-Ethernet) is alright as far as the hardware is concerned, and the module has full contact to the drive controller.

However, a check showed that the checksum of the "FIP" is incorrect.

Cause	Remedy
Checksum calculated by means of "Flash Info Page" (FIP) does not correspond to command checksum stored in "FIP". If optional module "ET" (Multi-Ethernet) previously worked correctly, parts of "FIP" were most likely overwritten in an impermissible way. If optional module "ET" previously did not work either, a problem occurred when "FIP" had been programmed.	Switch drive controller off and then on again. If error occurs again, please contact our service department

6.3.17 E Pge Sz

Brief Description: ET error: Flash geometry outside of defined size

Access to optional module "ET" (Multi-Ethernet) works correctly, but an error in size of "SPI Flash Page" was detected.

Diagnostic Messages when Booting the Devices

Cause	Remedy
Page size of SPI flash on optional module "ET" (Multi-Ethernet) read from "Flash Info Page" (FIP) is not supported by drive firmware. (Error message is displayed to avoid system crash.)	Update of drive firmware is required. Please contact our service department.

6.3.18 E MMC op

Brief Description: ET error: MMC could not be opened for reading
Content of MMC which has been plugged cannot be read.

Cause	Remedy
Name and/or path of firmware file (IBF file) are wrong - or - An error occurred when IBF file had been copied	Replace faulty MMC by MMC with correct content - or - Copy IBF file to MMC again on PC Afterwards, restart drive
MMC is defective	Replace MMC

6.3.19 E MMC cl

Brief Description: ET error: MMC could not be closed after reading
After the read access to the MMC, the MMC could not be closed.

Cause	Remedy
Directory structure of MMC is not correct	Check directory structure of MMC and correct it, if necessary
MMC is defective	Replace defective MMC by MMC which works

6.3.20 E Adress

Brief Description: ET error: Trying to read invalid address



This error can only occur when the MMC has been plugged and the MMC is basically alright.

There was an attempt to read ET software [software for the optional module "ET" (Multi Ethernet)] from the MMC address "0"; at this address, there cannot be any ET software.

Cause	Remedy
IBF firmware file does not contain ET software which is the case when file is smaller than 9MBytes - or - An error occurred when IBF file had been copied	Copy correct IBF file and restart drive

6.3.21 E Length

Brief Description: ET error: Reading number greater than maximum file size



This error can only occur with the MMC plugged in.

Diagnostic Messages when Booting the Devices

There was an attempt to read a number of bytes from the MMC and to write them to the SPI flash of the optional module "ET" (Multi-Ethernet); this number exceeds the maximum number of bytes of an ET logicware or firmware. [In the ET file (ET logicware or firmware), the actual length has been stored as an additional information.]

Cause	Remedy
Probably, a problem occurred when file had been transmitted	Copy IBF file to MMC again - or - Use MMC which works and restart drive

6.3.22 E ET SW

Brief Description: ET error: Error when copying from MMC to ET flash



This error can only occur with the MMC plugged in.

At least one of the ET softwares to be found, according to "Flash Info Page", on the SPI flash of the optional module "ET" (Multi-Ethernet) does not begin with "FWC_MEP"; this means that it is not a valid ET software.

Cause	Remedy
If no other error had been displayed before this error occurred, SPI flash on optional module "ET" (Multi-Ethernet) had only been written with "Flash Info Page".	Plug MMC with correct IBF file in drive and restart drive. Drive then copies all ET software modules, which were detected to be wrong or missing, from MMC to SPI flash of optional module "ET".
If another error had been displayed before this error occurred, IBF file is faulty	Plug MMC with correct IBF file in drive and restart drive

6.3.23 E MMC cp

Brief Description: ET error: Error when copying from MMC

This error can only occur with the MMC plugged in, and only if the MMC contains a different ET software than the one contained in the SPI flash of the optional module "ET" (Multi-Ethernet). (This means only when an update is to be made.) In this case, another error always occurs before; this error is displayed and specifies the problem in greater detail.

This error means that the transmission from the MMC to the SPI flash of the optional module "ET" could not be carried out successfully.

Cause	Remedy
Software structure on MMC is not alright	Check and correct MMC or use different MMC which works and restart drive

6.3.24 E HW nok

Brief Description: ET error: ET hardware signals not ready

The drive queries the FPGA on the optional module "ET" (Multi-Ethernet) for readiness for operation; readiness for operation was not signaled.

Diagnostic Messages when Booting the Devices

Cause	Remedy
Logicware file is defective	Restart drive with MMC plugged; drive gets logicware from MMC
A programming error is present	Please contact our service department to get new drive firmware / logicware and transmit it via MMC to drive / optional module "ET"
Optional module "ET" is defective	Please contact our service department

6.3.25 E SW-VER

Brief Description: ET error: Active LW or FW not supported version

When the drive had been booted, an error was detected with regard to the versions of the drive firmware and the software (logicware and firmware) on the optional module "ET" (Multi-Ethernet).

Cause	Remedy
Exactly one version of ET software (logicware and firmware) has been stored in each drive firmware. When drive had been booted, it was detected that version of drive firmware and one or several versions of software (logicware and firmware) on optional module "ET" (Multi-Ethernet) did not match.	By means of an MMC, ET software supported by drive firmware must be copied to optional module "ET". - or - Drive firmware update must be carried out so that drive firmware and ET software match again.

7 Diagnostic Status Messages

7.1 A0000 Communication phase 0

Allocation	Contained in 02VRS:	«MPB»	«MPH»	«MPD»	
	Contained in 03VRS:	«MPB»	«MPH»	«MPD»	
	Contained in 04VRS:	«MPB»	«MPH»	«MPD»	
	Contained in 05VRS:	«MPB»	«MPH»	«MPD»	
	Contained in 06VRS:	«MPB»	«MPH»	«MPD»	«MPC»
	Contained in 07VRS:	«MPB»	«MPH»	«MPD»	«MPC»
	Contained in 08VRS:	«MPB»	«MPH»	«MPD»	«MPC»
	Supported by supply unit:	«HMV»			

The communication between master and slaves via SERCOS interface is established in four communication phases:

The communication phases 0 and 1 are used to recognize the bus nodes. In the communication phase 2 the time and data build-up of the protocols are prepared for the communication phases 3 and 4.

The phase progression takes place in ascending order. The communication phase is set by the master. Switching to communication phase 4 completes the initialization and allows power input.

If the phase progression is interrupted, the status display remains in the communication phase that has been reached.

When the "A0000 Communication phase 0" diagnostic message is active the drive is in phase 0 and waits for the master's phase switch from communication phase 0 to 1.



On the display of Rexroth IndraDrive supply units, the text "VM" ("Versorgungs-Modul" = supply module) precedes the diagnostic message.

A0000 - Attributes	Display:	P0
	Ident N°:	A0000

7.2 A0001 Communication phase 1

Allocation	Contained in 02VRS:	«MPB»	«MPH»	«MPD»	
	Contained in 03VRS:	«MPB»	«MPH»	«MPD»	
	Contained in 04VRS:	«MPB»	«MPH»	«MPD»	
	Contained in 05VRS:	«MPB»	«MPH»	«MPD»	
	Contained in 06VRS:	«MPB»	«MPH»	«MPD»	«MPC»
	Contained in 07VRS:	«MPB»	«MPH»	«MPD»	«MPC»
	Contained in 08VRS:	«MPB»	«MPH»	«MPD»	«MPC»
	Supported by supply unit:	«HMV»			

The communication between master and slaves via SERCOS interface is established in four communication phases:

The communication phases 0 and 1 are used to recognize the bus nodes. In the communication phase 2 the time and data build-up of the protocols are prepared for the communication phases 3 and 4.

The phase progression takes place in ascending order. The communication phase is set by the master. Switching to communication phase 4 completes the initialization and allows power input.

If the phase progression is interrupted, the status display remains in the communication phase that has been reached.

Diagnostic Status Messages

When the "A0001 Communication phase 1" diagnostic message is active the drive is in phase 1, the master has not yet activated the phase switch from phase 1 to 2.



On the display of Rexroth IndraDrive supply units, the text "VM" ("Versorgungs-Modul" = supply module) precedes the diagnostic message.

A0001 - Attributes
 Display: P1
 Ident N°: A0001

7.3 A0002 Communication phase 2

Allocation	Contained in 02VRS:	«MPB»	«MPH»	«MPD»	
	Contained in 03VRS:	«MPB»	«MPH»	«MPD»	
	Contained in 04VRS:	«MPB»	«MPH»	«MPD»	
	Contained in 05VRS:	«MPB»	«MPH»	«MPD»	
	Contained in 06VRS:	«MPB»	«MPH»	«MPD»	«MPC»
	Contained in 07VRS:	«MPB»	«MPH»	«MPD»	«MPC»
	Contained in 08VRS:	«MPB»	«MPH»	«MPD»	«MPC»
	Supported by supply unit:	«H MV»			

Communication phase 2 means that the drive is in the parameterization mode. In this mode many parameters can be written that cannot be written any more in communication phase 4 (operating mode).

In communication phase 2

- the communication parameters are usually transmitted from the master to the drive (in the case of field bus and SERCOS devices) and
- the "Load drive parameters" and "Save drive parameters" ("file service") functions are carried out, if required.

In order to get to communication phase 2 the master, in the case of drives with field bus and SERCOS interfaces, sets "communication phase 2" via the master communication interface. Another possibility to switch to communication phase 2 is to execute the "P-0-4023, C0400 Communication phase 2 transition" command.

Communication Phase 3

Before it is possible to switch to communication phase 3 it is necessary to execute the "S-0-0127, C0100 Communication phase 3 transition check" command. Among other things the drive, during the transition check, checks the parameters required for communication phase 3 for validity.

After successful execution of the transition check command the master switches the drive to communication phase 3 (in the case of field bus and SERCOS devices) or the drive automatically switches to phase 3 at the end of the transition check command.



On the display of Rexroth IndraDrive supply units, the text "VM" ("Versorgungs-Modul" = supply module) precedes the diagnostic message.

A0002 - Attributes
 Display: P2
 Ident N°: A0002

7.4 A0003 Communication phase 3

Allocation	Contained in 02VRS:	«MPB»	«MPH»	«MPD»	
	Contained in 03VRS:	«MPB»	«MPH»	«MPD»	
	Contained in 04VRS:	«MPB»	«MPH»	«MPD»	
	Contained in 05VRS:	«MPB»	«MPH»	«MPD»	
	Contained in 06VRS:	«MPB»	«MPH»	«MPD»	«MPC»
	Contained in 07VRS:	«MPB»	«MPH»	«MPD»	«MPC»
	Contained in 08VRS:	«MPB»	«MPH»	«MPD»	«MPC»
	Supported by supply unit:	«HMV»			

Communication phase 3 means that the drive is in the **restricted** parameterization mode. In this mode, as in the parameterization mode (phase 2), many parameters can still be written that cannot be written any more in communication phase 4 (operating mode). Communication parameters cannot be written in phase 3.

In order to get to communication phase 3 the master, in the case of drives with field bus and SERCOS interfaces, sets "communication phase 3" via the master communication interface. Another possibility to switch to communication phase 3 is to execute the "S-0-0127, C0100 Communication phase 3 transition check" command.

Communication Phase 4

Before it is possible to switch to communication phase 4 it is necessary to execute the "S-0-0128, C0200 Communication phase 4 transition check" command. Among other things the drive, during the transition check, checks the parameters required for communication phase 4 for validity.

After successful execution of the transition check command the master switches the drive to communication phase 4 (in the case of field bus and SERCOS devices) or the drive automatically switches to phase 4 at the end of the transition check command.



On the display of Rexroth IndraDrive supply units, the text "VM" ("Versorgungs-Modul" = supply module) precedes the diagnostic message.

A0003 - Attributes	Display:	P3
	Ident N°:	A0003

7.5 A0009 Automatic baud rate detection for SERCOS interface

Allocation	Contained in 02VRS:	«MPB»	«MPH»	«MPD»	
	Contained in 03VRS:	«MPB»	«MPH»	«MPD»	
	Contained in 04VRS:	«MPB»	«MPH»	«MPD»	
	Contained in 05VRS:	«MPB»	«MPH»	«MPD»	
	Contained in 06VRS:	«MPB»	«MPH»	«MPD»	«MPC»
	Contained in 07VRS:	«MPB»	«MPH»	«MPD»	«MPC»
	Contained in 08VRS:	«MPB»	«MPH»	«MPD»	«MPC»
	Supported by supply unit:	«-»			

The communication between master and slaves via SERCOS interface is established in four communication phases:

The communication phases 0 and 1 are used to recognize the bus nodes. In the communication phase 2 the time and data build-up of the protocols are prepared for the communication phases 3 and 4.

The phase progression takes place in ascending order. The communication phase is set by the master. Switching to communication phase 4 completes the initialization and allows power input.

If the phase progression is interrupted, the status display remains in the communication phase that has been reached.

Diagnostic Status Messages

If the "A0009 Automatic baud rate detection for SERCOS interface" diagnostic message is active, the drive is in phase 0 - 1, the progression to phase 0 is carried out at the moment when the correct baud rate is detected.

A0009 - Attributes **Display:** P -1
 Ident N°: A0009

7.6 A0010 Drive HALT

Allocation	Contained in 02VRS:	«MPB»	«MPH»	«MPD»	
	Contained in 03VRS:	«MPB»	«MPH»	«MPD»	
	Contained in 04VRS:	«MPB»	«MPH»	«MPD»	
	Contained in 05VRS:	«MPB»	«MPH»	«MPD»	
	Contained in 06VRS:	«MPB»	«MPH»	«MPD»	«MPC»
	Contained in 07VRS:	«MPB»	«MPH»	«MPD»	«MPC»
	Contained in 08VRS:	«MPB»	«MPH»	«MPD»	«MPC»
	Supported by supply unit:	«-»			

Function "Drive Halt" is indirectly activated by the master via the master communication interface by deleting the Drive Halt bit in parameter "S-0-0134, Master control word" or by interrupting a drive control command (e.g., drive-controlled homing procedure).

The "Drive Halt" function is used to shut down an axis with defined acceleration and defined jerk.

Function "Drive Halt" can be executed as **quick stop** in **position control** or **velocity control** mode or as **operational stop** in the active operation mode with velocity command value reset [see configuration "Drive Halt" (P-0-0558)].

See also Functional Description of firmware "Drive Halt"

A0010 - Attributes **Display:** AH
 Ident N°: A0010

7.7 A0011 Safe torque off active

Allocation	Contained in 02VRS:	«MPB»	«MPH»	«MPD»	
	Contained in 03VRS:	«MPB»	«MPH»	«MPD»	
	Contained in 04VRS:	«MPB»	«MPH»	«MPD»	
	Contained in 05VRS:	«MPB»	«MPH»	«MPD»	
	Contained in 06VRS:	«MPB»	«MPH»	«MPD»	«MPC»
	Contained in 07VRS:	«MPB»	«MPH»	«MPD»	«MPC»
	Contained in 08VRS:	«MPB»	«MPH»	«MPD»	«MPC»
	Supported by supply unit:	«-»			



Up to MPx06, the name of this diagnostic message was "A0011 Starting lockout active".

Up to MPx06 As an option, certain digital drive controllers can be equipped with a starting lockout. The starting lockout prevents the unintended start of a servo axis. This is realized by separating the electronic control system of the power output stage from the power output stage by means of a relay contact.

See also Project Planning Manual for Control Section, index entry "Starting lockout L1"

As of MPx07 As an option, certain digital drive controllers can be equipped with the optional safety technology module "Safe Torque Off". The optional safety technology module prevents the unintended start of a servo axis. This is realized by separating the electronic control system of the power output stage from the power output stage by means of a relay contact.

Diagnostic Status Messages

See also Project Planning Manual for Control Section, index entry "Safe Torque Off, L2"



Up to MPx06, the display showed "AS".

A0011 - Attributes Display: STO
 Ident N°: A0011

7.8 A0012 Control and power sections ready for operation

Allocation	Contained in 02VRS:	«MPB»	«MPH»	«MPD»	
	Contained in 03VRS:	«MPB»	«MPH»	«MPD»	
	Contained in 04VRS:	«MPB»	«MPH»	«MPD»	
	Contained in 05VRS:	«MPB»	«MPH»	«MPD»	
	Contained in 06VRS:	«MPB»	«MPH»	«MPD»	«MPC»
	Contained in 07VRS:	«MPB»	«MPH»	«MPD»	«MPC»
	Contained in 08VRS:	«MPB»	«MPH»	«MPD»	«MPC»
	Supported by supply unit:	«HMV»			

For HMS, HMD, HCS The diagnostic message "A0012 Control and power sections ready for operation" signals that the drive has been supplied with control voltage and power has been switched on. The drive is ready for power output.

For HMV The diagnostic message "A0012 Control and power sections ready for operation" signals that the supply unit is ready to switch on the mains contactor.



Mains contactor cannot be switched on in spite of "VM bb" !

In spite of the display "VM Bb" or "VM bb", it can sometimes be impossible to switch the mains contactor on.

Possible cause:

This can be caused by a defective external mains contactor with, for example, contacts stuck together. The error message "F2837 Contactor monitoring error" cannot be diagnosed in such cases.

With contacts of the main circuit stuck together, the N/C contact (X40.1/2) remains open in the position of rest and the switch-on circuit is thereby interrupted.

Remedy:

Check and, if necessary, replace the external mains contactor.

A0012 - Attributes Display: Ab
 Ident N°: A0012

7.9 A0013 Ready for power on

Allocation	Contained in 02VRS:	«MPB»	«MPH»	«MPD»	
	Contained in 03VRS:	«MPB»	«MPH»	«MPD»	
	Contained in 04VRS:	«MPB»	«MPH»	«MPD»	
	Contained in 05VRS:	«MPB»	«MPH»	«MPD»	
	Contained in 06VRS:	«MPB»	«MPH»	«MPD»	«MPC»
	Contained in 07VRS:	«MPB»	«MPH»	«MPD»	«MPC»
	Contained in 08VRS:	«MPB»	«MPH»	«MPD»	«MPC»
	Supported by supply unit:	«HMV»			

The diagnostic message "A0013 Ready for power on" signals that the drive or supply unit has been provided with control voltage and that there isn't any error present in the drive/supply unit.

The drive or the supply unit is ready for power on.

Diagnostic Status Messages

**Mains contactor cannot be switched on in spite of "VM bb" !**

In spite of the display "VM Bb" or "VM bb", it can sometimes be impossible to switch the mains contactor on.

Possible cause:

This can be caused by a defective external mains contactor with, for example, contacts stuck together. The error message "F2837 Contactor monitoring error" cannot be diagnosed in such cases.

With contacts of the main circuit stuck together, the N/C contact (X40.1/2) remains open in the position of rest and the switch-on circuit is thereby interrupted.

Remedy:

Check and, if necessary, replace the external mains contactor.

A0013 - Attributes

Display: bb
Ident N°: A0013

7.10 A0014 Safe stop 1 (Emergency stop) active

Allocation	Contained in 02VRS:	«MPB»	«MPH»	«MPD»	
	Contained in 03VRS:	«MPB»	«MPH»	«MPD»	
	Contained in 04VRS:	«MPB»	«MPH»	«MPD»	
	Contained in 05VRS:	«MPB»	«MPH»	«MPD»	
	Contained in 06VRS:	«MPB»	«MPH»	«MPD»	«MPC»
	Contained in 07VRS:	«MPB»	«MPH»	«MPD»	«MPC»
	Contained in 08VRS:	«MPB»	«MPH»	«MPD»	«MPC»
	Supported by supply unit:	«-»			



Up to MPx06, the name of this diagnostic message was "A0014 Drive interlock active".

The drive is in the special mode "safe standstill". The active safety function is "safety related drive interlock" (up to MPx06) or "Safe stop 1 (Emergency stop)" (as of MPx07).



When the safety function "safety related drive interlock"/"Safe stop 1 (Emergency stop)" is active, bit 1 is set in "P-0-3213, Safety technology operating status".

The drive has come to standstill, the power supply has been interrupted via two channels (output stage locked).

⚠ DANGER

Dangerous movements! Danger to life, risk of injury, serious injury or property damage!

After the output stage has been locked, standstill monitoring is not active. If external force influences are to be expected, e.g. in the case of a vertical axis, this motion has to be safely prevented by additional measures, e.g. a mechanical brake or weight compensation.

The safety function "safety related drive interlock"/"Safe stop 1 (Emergency stop)" cannot be deselected by the enabling control, but only by resetting the selection.



Up to MPx06, the display showed "ASP".

A0014 - Attributes Display: SS1ES
 Ident N°: A0014

7.11 A0015 Safe stop 1 active

Allocation	Contained in 02VRS:	«MPB»	«MPH»	«MPD»	
	Contained in 03VRS:	«MPB»	«MPH»	«MPD»	
	Contained in 04VRS:	«MPB»	«MPH»	«MPD»	
	Contained in 05VRS:	«MPB»	«MPH»	«MPD»	
	Contained in 06VRS:	«MPB»	«MPH»	«MPD»	«MPC»
	Contained in 07VRS:	«MPB»	«MPH»	«MPD»	«MPC»
	Contained in 08VRS:	«MPB»	«MPH»	«MPD»	«MPC»
	Supported by supply unit:	«-»			

 Up to MPx06, the name of this diagnostic message was "A0015 Safety related standstill active".

The drive is in the special mode "safe standstill". The active safety function is "safety related standstill" (up to MPx06) or "Safe stop 1" (as of MPx07).

 When the safety function "safety related standstill"/"Safe stop 1" is active, bit 2 is set in "P-0-3213, Safety technology operating status".

The drive has come to standstill, the power supply has been interrupted via two channels (output stage locked).

If the drive is still in motion when "safety related standstill"/"Safe stop 1" is selected, there first is a stopping process, then the power supply is interrupted via two channels (output stage locked).

 DANGER Dangerous movements! Danger to life, risk of injury, serious injury or property damage!

After the output stage has been locked, standstill monitoring is not active. If external force influences are to be expected, e.g. in the case of a vertical axis, this motion has to be safely prevented by additional measures, e.g. a mechanical brake or weight compensation.

 Up to MPx06, the display showed "SH".

A0015 - Attributes Display: SS1
 Ident N°: A0015

7.12 A0016 Safe stop 2 active

Allocation	Contained in 02VRS:	«MPB»	«MPH»	«MPD»	
	Contained in 03VRS:	«MPB»	«MPH»	«MPD»	
	Contained in 04VRS:	«MPB»	«MPH»	«MPD»	
	Contained in 05VRS:	«MPB»	«MPH»	«MPD»	
	Contained in 06VRS:	«MPB»	«MPH»	«MPD»	«MPC»
	Contained in 07VRS:	«MPB»	«MPH»	«MPD»	«MPC»
	Contained in 08VRS:	«MPB»	«MPH»	«MPD»	«MPC»
	Supported by supply unit:	«-»			

 Up to MPx06, the name of this diagnostic message was "A0016 Safety related operational stop active".

Diagnostic Status Messages

The drive is in the special mode "safe standstill". The active safety function is "safety related operational stop" (up to MPx06) or "Safe stop 2" (as of MPx07).



When the safety function "safety related operational stop"/"Safe stop 2" is active, bit 2 is set in "P-0-3213, Safety technology operating status".

The drive has come to standstill, the power supply has not been interrupted, all control loops are active, the standstill monitors are active.

If the drive is still in motion when "safety related operational stop"/"Safe stop 2" is selected, there first is a stopping process, then the standstill monitors become active (axis/spindle cannot be moved). When the drive leaves the standstill position, the output stage is locked via two channels.

DANGER

Dangerous movements! Danger to life, risk of injury, serious injury or property damage!

After the output stage has been locked, standstill monitoring is not active. If external force influences are to be expected, e.g. in the case of a vertical axis, this motion has to be safely prevented by additional measures, e.g. a mechanical brake or weight compensation.



Up to MPx06, the display showed "SBH".

A0016 - Attributes

Display: SS2
Ident N°: A0016

7.13 A0017 Special mode motion active

Allocation	Contained in 02VRS:	«MPB»	«MPH»	«MPD»	
	Contained in 03VRS:	«MPB»	«MPH»	«MPD»	
	Contained in 04VRS:	«-»	«-»	«-»	
	Contained in 05VRS:	«-»	«-»	«-»	
	Contained in 06VRS:	«-»	«-»	«-»	«-»
	Contained in 07VRS:	«-»	«-»	«-»	«-»
	Contained in 08VRS:	«-»	«-»	«-»	«-»
	Supported by supply unit:	«-»			

The drive is in one of up to four special "safe motion" operating states that can be differently configured and selected.

By means of parameters

- "P-0-3240, Configuration of safe motion 1",
- "P-0-3250, Configuration of safe motion 2",
- "P-0-3260, Configuration of safe motion 3", and
- "P-0-3270, Configuration of safe motion 4"

it is possible to configure different characteristics of the special mode "safe motion".

When a limit value of the configured and selected safety functions has been exceeded, the drive system is brought to standstill in a safe way, then the power supply is interrupted via two channels (output stage locked).

Diagnostic Status Messages

⚠ DANGER Dangerous movements! Danger to life, risk of injury, serious injury or property damage!

After the output stage has been locked, standstill monitoring is not active. If external force influences are to be expected, e.g. in the case of a vertical axis, this motion has to be safely prevented by additional measures, e.g. a mechanical brake or weight compensation.

 According to selection, bit 3, 4, 5 or 6 is set in parameter "P-0-3213, Safety technology status" (or "P03213, Safety technology operating status").

Safety related reduced speed	With the safety function "safety related reduced speed", the drive can only be moved with reduced speed. The speed monitors are active.
Safe direction	With the safety function "safe direction", the drive can only move in a determined direction with reduced speed. The speed monitors are active.
Safely-limited increment	With the safety function "safely-limited increment", the drive may only travel a maximum of one fixed increment after the special mode was selected. The drive moves at reduced speed. The speed and position monitors are active.
Safety related limited absolute position	With the safety function "safety related limited absolute position", absolute position monitors are active. The drive may only move within the range limits. NOTE: Before the safety function "safety related limited absolute position" is selected, the "safety related homing procedure" has to be carried out.

A0017 - Attributes Display: SBB
 Ident N°: A0017

7.14 A0018 Special mode safe motion 1 active

Allocation	Contained in 02VRS:	«-»	«-»	«-»	
	Contained in 03VRS:	«-»	«-»	«-»	
	Contained in 04VRS:	«MPB»	«MPH»	«MPD»	
	Contained in 05VRS:	«MPB»	«MPH»	«MPD»	
	Contained in 06VRS:	«MPB»	«MPH»	«MPD»	«MPC»
	Contained in 07VRS:	«MPB»	«MPH»	«MPD»	«MPC»
	Contained in 08VRS:	«MPB»	«MPH»	«MPD»	«MPC»
	Supported by supply unit:	«-»			

 Up to MPx06, the name of this diagnostic message was "A0018 Special mode motion 1 active".

The drive is in the special mode "safe motion 1" that can be configured and selected.

By means of parameter "P-0-3240, Configuration of safe motion 1", it is possible to configure different characteristics of the special mode "safe motion 1".

When a limit value of the configured and selected safety functions has been exceeded, the drive system is brought to standstill in a safe way, then the power supply is interrupted via two channels (output stage locked).

Diagnostic Status Messages

⚠ DANGER**Dangerous movements! Danger to life, risk of injury, serious injury or property damage!**

After the output stage has been locked, standstill monitoring is not active. If external force influences are to be expected, e.g., in the case of a vertical axis, this motion has to be safely prevented by additional measures, e.g., a mechanical brake or weight compensation.



Bit 3 is set in "P-0-3213, Safety technology operating status".

Name of the safety function up to MPx06	Name of the safety function as of MPx07	Limit value monitoring
Safety related reduced speed	Safely-limited speed	With the safety function "safety related reduced speed"/"safely-limited speed", the drive can only be moved with reduced/limited speed. The speed monitors are active.
Safe direction	Safe direction	With the safety function "safety related direction of motion", the drive can only move in a determined direction with reduced/limited speed. The speed monitors are active.
Safely-limited increment	Safely-limited increment	With the safety function "safety-limited increment", the drive may only travel a maximum of one fixed increment after the special mode was selected. The drive moves at reduced/limited speed. The speed and position monitors are active.
Safety-limited absolute position	Safely-monitored position	With the safety function "safety-limited absolute position"/"Safely-monitored position", position monitors are active. The drive may only move within the range limits. NOTE: Before the safety function "safety related limited absolute position"/"Safely-monitored position" is selected, the safe homing procedure has to be carried out.



Up to MPx06, the display showed "SBB1".

A0018 - Attributes

Display: SMM1
Ident N°: A0018

7.15 A0019 Special mode safe motion 2 active

Allocation	Contained in 02VRS:	«-»	«-»	«-»	
	Contained in 03VRS:	«-»	«-»	«-»	
	Contained in 04VRS:	«MPB»	«MPH»	«MPD»	
	Contained in 05VRS:	«MPB»	«MPH»	«MPD»	
	Contained in 06VRS:	«MPB»	«MPH»	«MPD»	«MPC»
	Contained in 07VRS:	«MPB»	«MPH»	«MPD»	«MPC»
	Contained in 08VRS:	«MPB»	«MPH»	«MPD»	«MPC»
	Supported by supply unit:	«-»			



Up to MPx06, the name of this diagnostic message was "A0019 Special mode motion 2 active".

The drive is in the special mode "safe motion 2" that can be configured and selected.

Diagnostic Status Messages

By means of parameter "P-0-3250, Configuration of safe motion 2", it is possible to configure different characteristics of the special mode "safe motion 2".

When a limit value of the configured and selected safety functions has been exceeded, the drive system is brought to standstill in a safe way, then the power supply is interrupted via two channels (output stage locked).

⚠ DANGER Dangerous movements! Danger to life, risk of injury, serious injury or property damage!

After the output stage has been locked, standstill monitoring is not active. If external force influences are to be expected, e.g., in the case of a vertical axis, this motion has to be safely prevented by additional measures, e.g., a mechanical brake or weight compensation.

 Bit 4 is set in parameter "P-0-3213, Safety technology operating status".

Name of the safety function up to MPx06	Name of the safety function as of MPx07	Limit value monitoring
Safety related reduced speed	Safely-limited speed	With the safety function "safety related reduced speed"/"safely-limited speed", the drive can only be moved with reduced/limited speed. The speed monitors are active.
Safe direction	Safe direction	With the safety function "safety related direction of motion", the drive can only move in a determined direction with reduced/limited speed. The speed monitors are active.
Safely-limited increment	Safely-limited increment	With the safety function "safety-limited increment", the drive may only travel a maximum of one fixed increment after the special mode was selected. The drive moves at reduced/limited speed. The speed and position monitors are active.
Safely-limited absolute position	Safely-monitored position	With the safety function "safety-limited absolute position"/"Safely-monitored position", position monitors are active. The drive may only move within the range limits. NOTE: Before the safety function "safety related limited absolute position"/"Safely-monitored position" is selected, the safe homing procedure has to be carried out.

 Up to MPx06, the display showed "SBB2".

A0019 - Attributes Display: SMM2
 Ident N°: A0019

7.16 A0020 Special mode safe motion 3 active

Allocation	Contained in 02VRS:	«-»	«-»	«-»	
	Contained in 03VRS:	«-»	«-»	«-»	
	Contained in 04VRS:	«MPB»	«MPH»	«MPD»	
	Contained in 05VRS:	«MPB»	«MPH»	«MPD»	
	Contained in 06VRS:	«MPB»	«MPH»	«MPD»	«MPC»
	Contained in 07VRS:	«MPB»	«MPH»	«MPD»	«MPC»
	Contained in 08VRS:	«MPB»	«MPH»	«MPD»	«MPC»
	Supported by supply unit:	«-»			

Diagnostic Status Messages



Up to MPx06, the name of this diagnostic message was "A0020 Special mode motion 3 active".

The drive is in the special mode "safe motion 3" that can be configured and selected.

By means of parameter "P-0-3260, Configuration of safe motion 3", it is possible to configure different characteristics of the special mode "safe motion 3".

When a limit value of the configured and selected safety functions has been exceeded, the drive system is brought to standstill in a safe way, then the power supply is interrupted via two channels (output stage locked).

⚠ DANGER

Dangerous movements! Danger to life, risk of injury, serious injury or property damage!

After the output stage has been locked, standstill monitoring is not active. If external force influences are to be expected, e.g., in the case of a vertical axis, this motion has to be safely prevented by additional measures, e.g., a mechanical brake or weight compensation.



Bit 5 is set in parameter "P-0-3213, Safety technology operating status".

Name of the safety function up to MPx06	Name of the safety function as of MPx07	Limit value monitoring
Safety related reduced speed	Safely-limited speed	With the safety function "safety related reduced speed"/"safely-limited speed", the drive can only be moved with reduced/limited speed. The speed monitors are active.
Safe direction	Safe direction	With the safety function "safety related direction of motion", the drive can only move in a determined direction with reduced/limited speed. The speed monitors are active.
Safely-limited increment	Safely-limited increment	With the safety function "safety-limited increment", the drive may only travel a maximum of one fixed increment after the special mode was selected. The drive moves at reduced/limited speed. The speed and position monitors are active.
Safety-limited absolute position	Safely-monitored position	With the safety function "safety-limited absolute position"/"Safely-monitored position", position monitors are active. The drive may only move within the range limits. NOTE: Before the safety function "safety related limited absolute position"/"Safely-monitored position" is selected, the safe homing procedure has to be carried out.



Up to MPx06, the display showed "SBB3".

A0020 - Attributes

Display: SMM3
Ident N°: A0020

7.17 A0021 Special mode safe motion 4 active

Allocation	Contained in 02VRS:	«-»	«-»	«-»	
	Contained in 03VRS:	«-»	«-»	«-»	
	Contained in 04VRS:	«MPB»	«MPH»	«MPD»	
	Contained in 05VRS:	«MPB»	«MPH»	«MPD»	
	Contained in 06VRS:	«MPB»	«MPH»	«MPD»	«MPC»
	Contained in 07VRS:	«MPB»	«MPH»	«MPD»	«MPC»
	Contained in 08VRS:	«MPB»	«MPH»	«MPD»	«MPC»
	Supported by supply unit:	«-»			



Up to MPx06, the name of this diagnostic message was "A0021 Special mode motion 4 active".

The drive is in the special mode "safe motion 4" that can be configured and selected.

By means of parameter "P-0-3270, Configuration of safe motion 4", it is possible to configure different characteristics of the special mode "safe motion 4".

When a limit value of the configured and selected safety function has been exceeded, the drive system is brought to standstill in a safe way, then the power supply is interrupted via two channels (output stage locked).

DANGER

Dangerous movements! Danger to life, risk of injury, serious injury or property damage!

After the output stage has been locked, standstill monitoring is not active. If external force influences are to be expected, e.g., in the case of a vertical axis, this motion has to be safely prevented by additional measures, e.g., a mechanical brake or weight compensation.



Bit 6 is set in parameter "P-0-3213, Safety technology operating status".

Name of the safety function up to MPx06	Name of the safety function as of MPx07	Limit value monitoring
Safety related reduced speed	Safely-limited speed	With the safety function "safety related reduced speed"/"safely-limited speed", the drive can only be moved with reduced/limited speed. The speed monitors are active.
Safe direction	Safe direction	With the safety function "safety related direction of motion", the drive can only move in a determined direction with reduced/limited speed. The speed monitors are active.
Safely-limited increment	Safely-limited increment	With the safety function "safety-limited increment", the drive may only travel a maximum of one fixed increment after the special mode was selected. The drive moves at reduced/limited speed. The speed and position monitors are active.
Safely-limited absolute position	Safely-monitored position	With the safety function "safety-limited absolute position"/"Safely-monitored position", position monitors are active. The drive may only move within the range limits. NOTE: Before the safety function "safety related limited absolute position"/"Safely-monitored position" is selected, the safe homing procedure has to be carried out.

Diagnostic Status Messages



Up to MPx06, the display showed "SBB4".

A0021 - Attributes Display: SMM4
 Ident N°: A0021

7.18 A0050 Parameterization level 1 active

Allocation	Contained in 02VRS:	«-»	«-»	«-»	
	Contained in 03VRS:	«-»	«-»	«-»	
	Contained in 04VRS:	«MPB»	«MPH»	«MPD»	
	Contained in 05VRS:	«MPB»	«MPH»	«MPD»	
	Contained in 06VRS:	«MPB»	«MPH»	«MPD»	«MPC»
	Contained in 07VRS:	«MPB»	«MPH»	«MPD»	«MPC»
	Contained in 08VRS:	«MPB»	«MPH»	«MPD»	«MPC»
	Supported by supply unit:	«-»			

The drive is in the "Parameterization level 1" mode. In this status, the monitoring functions of the position encoders and the motor temperature sensor are deactivated. Although the master communication is in communication phase 4, the drive can be parameterized as in communication phase 3.



This status is displayed on the control panel of the drive with "PM".

See also Functional Description of firmware "Parking Axis"

See also Parameter Description "S-0-0420, C0400 Activate parameterization level 1 procedure command"

A0050 - Attributes Display: PM
 Ident N°: A0050

7.19 A0051 Operating mode

Allocation	Contained in 02VRS:	«-»	«-»	«-»	
	Contained in 03VRS:	«-»	«-»	«-»	
	Contained in 04VRS:	«MPB»	«MPH»	«MPD»	
	Contained in 05VRS:	«MPB»	«MPH»	«MPD»	
	Contained in 06VRS:	«MPB»	«MPH»	«MPD»	«MPC»
	Contained in 07VRS:	«MPB»	«MPH»	«MPD»	«MPC»
	Contained in 08VRS:	«MPB»	«MPH»	«MPD»	«MPC»
	Supported by supply unit:	«-»			

The axis was switched to operating mode, but the master communication is not yet in cyclic data exchange. Axis control is not yet possible in this status.

A0051 - Attributes Display: OM
 Ident N°: A0051

7.20 A0100 Torque control

Allocation	Contained in 02VRS:	«MPB»	«MPH»	«MPD»	
	Contained in 03VRS:	«MPB»	«MPH»	«MPD»	
	Contained in 04VRS:	«MPB»	«MPH»	«MPD»	
	Contained in 05VRS:	«MPB»	«MPH»	«MPD»	
	Contained in 06VRS:	«MPB»	«MPH»	«MPD»	«MPC»
	Contained in 07VRS:	«MPB»	«MPH»	«MPD»	«MPC»
	Contained in 08VRS:	«MPB»	«MPH»	«MPD»	«MPC»
	Supported by supply unit:	«-»			

The drive is in the "Torque control" mode. It follows the torque command value characteristic set by the master.

See also Functional Description of firmware "Torque/Force Control"

A0100 - Attributes Display: AF
 Ident N°: A0100

7.21 A0101 Velocity control

Allocation	Contained in 02VRS:	«MPB»	«MPH»	«MPD»	
	Contained in 03VRS:	«MPB»	«MPH»	«MPD»	
	Contained in 04VRS:	«MPB»	«MPH»	«MPD»	
	Contained in 05VRS:	«MPB»	«MPH»	«MPD»	
	Contained in 06VRS:	«MPB»	«MPH»	«MPD»	«MPC»
	Contained in 07VRS:	«MPB»	«MPH»	«MPD»	«MPC»
	Contained in 08VRS:	«MPB»	«MPH»	«MPD»	«MPC»
	Supported by supply unit:	«-»			

The drive is in the "Velocity control" mode. It follows the speed command value characteristic set by the master. The speed control loop is closed in the drive.

See also Functional Description of firmware "Velocity Control"

A0101 - Attributes Display: AF
 Ident N°: A0101

7.22 A0102 Position mode, encoder 1

Allocation	Contained in 02VRS:	«MPB»	«MPH»	«MPD»	
	Contained in 03VRS:	«MPB»	«MPH»	«MPD»	
	Contained in 04VRS:	«MPB»	«MPH»	«MPD»	
	Contained in 05VRS:	«MPB»	«MPH»	«MPD»	
	Contained in 06VRS:	«MPB»	«MPH»	«MPD»	«MPC»
	Contained in 07VRS:	«MPB»	«MPH»	«MPD»	«MPC»
	Contained in 08VRS:	«MPB»	«MPH»	«MPD»	«MPC»
	Supported by supply unit:	«-»			

The drive is in position control. The position control loop is closed by means of a position encoder in the drive. The master only specifies the position command value characteristic, the drive follows the command value with a lag error.

"Encoder 1" means that the encoder assigned by means of "P-0-0077, Assignment motor encoder->optional slot" is used as a control encoder.

See also Functional Description of firmware "Position Control with Cyclic Command Value Input"

A0102 - Attributes Display: AF
 Ident N°: A0102

7.23 A0103 Position mode, encoder 2

Allocation	Contained in 02VRS:	«MPB»	«MPH»	«MPD»	
	Contained in 03VRS:	«MPB»	«MPH»	«MPD»	
	Contained in 04VRS:	«MPB»	«MPH»	«MPD»	
	Contained in 05VRS:	«MPB»	«MPH»	«MPD»	
	Contained in 06VRS:	«MPB»	«MPH»	«MPD»	«MPC»
	Contained in 07VRS:	«MPB»	«MPH»	«MPD»	«MPC»
	Contained in 08VRS:	«MPB»	«MPH»	«MPD»	«MPC»
	Supported by supply unit:	«-»			

The drive is in position control. The position control loop is closed by means of a position encoder in the drive. The master only specifies the position command value characteristic, the drive follows the command value with a lag error.

Diagnostic Status Messages

"Encoder 2" means that the encoder assigned by means of "P-0-0078, Assignment optional encoder->optional slot" is used as a control encoder.

See also Functional Description of firmware "Position Control with Cyclic Command Value Input"

A0103 - Attributes **Display:** AF
 Ident N°: A0103

7.24 A0104 Position mode lagless, encoder 1

Allocation	Contained in 02VRS:	«MPB»	«MPH»	«MPD»	
	Contained in 03VRS:	«MPB»	«MPH»	«MPD»	
	Contained in 04VRS:	«MPB»	«MPH»	«MPD»	
	Contained in 05VRS:	«MPB»	«MPH»	«MPD»	
	Contained in 06VRS:	«MPB»	«MPH»	«MPD»	«MPC»
	Contained in 07VRS:	«MPB»	«MPH»	«MPD»	«MPC»
	Contained in 08VRS:	«MPB»	«MPH»	«MPD»	«MPC»
	Supported by supply unit:	«-»			

The drive is in position control. The position control loop is closed by means of a position encoder in the drive. The master only specifies the position command value characteristic, the drive follows the command value laglessly (prerequisite: "P-0-0040, Velocity feedforward evaluation"=100%).

"Encoder 1" means that the encoder assigned by means of "P-0-0077, Assignment motor encoder->optional slot" is used as a control encoder.

See also Functional Description of firmware "Position Control with Cyclic Command Value Input"

A0104 - Attributes **Display:** AF
 Ident N°: A0104

7.25 A0105 Position mode lagless, encoder 2

Allocation	Contained in 02VRS:	«MPB»	«MPH»	«MPD»	
	Contained in 03VRS:	«MPB»	«MPH»	«MPD»	
	Contained in 04VRS:	«MPB»	«MPH»	«MPD»	
	Contained in 05VRS:	«MPB»	«MPH»	«MPD»	
	Contained in 06VRS:	«MPB»	«MPH»	«MPD»	«MPC»
	Contained in 07VRS:	«MPB»	«MPH»	«MPD»	«MPC»
	Contained in 08VRS:	«MPB»	«MPH»	«MPD»	«MPC»
	Supported by supply unit:	«-»			

The drive is in position control. The position control loop is closed by means of a position encoder in the drive. The master only specifies the position command value characteristic, the drive follows the command value laglessly (prerequisite: "P-0-0040, Velocity feedforward evaluation"=100%).

"Encoder 2" means that the encoder assigned by means of "P-0-0078, Assignment optional encoder->optional slot" is used as a control encoder.

See also Functional Description of firmware "Position Control with Cyclic Command Value Input"

A0105 - Attributes **Display:** AF
 Ident N°: A0105

7.26 A0106 Drive-internal interpolation, encoder 1

Allocation	Contained in 02VRS:	«MPB»	«MPH»	«MPD»	
	Contained in 03VRS:	«MPB»	«MPH»	«MPD»	
	Contained in 04VRS:	«MPB»	«MPH»	«MPD»	
	Contained in 05VRS:	«MPB»	«MPH»	«MPD»	
	Contained in 06VRS:	«MPB»	«MPH»	«MPD»	«MPC»
	Contained in 07VRS:	«MPB»	«MPH»	«MPD»	«MPC»
	Contained in 08VRS:	«MPB»	«MPH»	«MPD»	«MPC»
	Supported by supply unit:	«-»			

From the control unit the drive receives a position command value identical to the target position of the distance to be traveled. The drive then generates (interpolates) an internal position command value characteristic that complies with the maximum values for the jerk, acceleration and velocity characteristic determined by the master.

With a lag error the drive moves to the target position.

"Encoder 1" means that the encoder assigned by means of "P-0-0077, Assignment motor encoder->optional slot" is used as a control encoder.

See also Functional Description of firmware "Drive Internal Interpolation"

A0106 - Attributes	Display:	AF
	Ident N°:	A0106

7.27 A0107 Drive-internal interpolation, encoder 2

Allocation	Contained in 02VRS:	«MPB»	«MPH»	«MPD»	
	Contained in 03VRS:	«MPB»	«MPH»	«MPD»	
	Contained in 04VRS:	«MPB»	«MPH»	«MPD»	
	Contained in 05VRS:	«MPB»	«MPH»	«MPD»	
	Contained in 06VRS:	«MPB»	«MPH»	«MPD»	«MPC»
	Contained in 07VRS:	«MPB»	«MPH»	«MPD»	«MPC»
	Contained in 08VRS:	«MPB»	«MPH»	«MPD»	«MPC»
	Supported by supply unit:	«-»			

From the master the drive receives a position command value identical to the target position of the distance to be traveled. The drive then generates (interpolates) an internal position command value characteristic that complies with the maximum values for the jerk, acceleration and velocity characteristic determined by the master.

With a lag error the drive moves to the target position.

"Encoder 2" means that the encoder assigned by means of "P-0-0078, Assignment optional encoder->optional slot" is used as a control encoder.

See also Functional Description of firmware "Drive Internal Interpolation"

A0107 - Attributes	Display:	AF
	Ident N°:	A0107

7.28 A0108 Drive controlled interpolation, lagless, encoder 1

Allocation	Contained in 02VRS:	«MPB»	«MPH»	«MPD»	
	Contained in 03VRS:	«MPB»	«MPH»	«MPD»	
	Contained in 04VRS:	«MPB»	«MPH»	«MPD»	
	Contained in 05VRS:	«MPB»	«MPH»	«MPD»	
	Contained in 06VRS:	«MPB»	«MPH»	«MPD»	«MPC»
	Contained in 07VRS:	«MPB»	«MPH»	«MPD»	«MPC»
	Contained in 08VRS:	«MPB»	«MPH»	«MPD»	«MPC»
	Supported by supply unit:	«-»			

From the master the drive receives a position command value identical to the target position of the distance to be traveled. The drive then generates (inter-

Diagnostic Status Messages

polates) an internal position command value characteristic that complies with the maximum values for the jerk, acceleration and velocity characteristic determined by the master.

The drive laglessly moves to the target position (prerequisite: "P-0-0040, Velocity feedforward evaluation"=100%).

"Encoder 1" means that the encoder assigned by means of "P-0-0077, Assignment motor encoder->optional slot" is used as a control encoder.

See also Functional Description of firmware "Drive Internal Interpolation"

A0108 - Attributes Display: AF
 Ident N°: A0108

7.29 A0109 Drive controlled interpolation, lagless, encoder 2

Allocation	Contained in 02VRS:	«MPB»	«MPH»	«MPD»	
	Contained in 03VRS:	«MPB»	«MPH»	«MPD»	
	Contained in 04VRS:	«MPB»	«MPH»	«MPD»	
	Contained in 05VRS:	«MPB»	«MPH»	«MPD»	
	Contained in 06VRS:	«MPB»	«MPH»	«MPD»	«MPC»
	Contained in 07VRS:	«MPB»	«MPH»	«MPD»	«MPC»
	Contained in 08VRS:	«MPB»	«MPH»	«MPD»	«MPC»
	Supported by supply unit:	«-»			

From the master the drive receives a position command value identical to the target position of the distance to be traveled. The drive then generates (interpolates) an internal position command value characteristic that complies with the maximum values for the jerk, acceleration and velocity characteristic determined by the master.

The drive laglessly moves to the target position (prerequisite: "P-0-0040, Velocity feedforward evaluation"=100%).

"Encoder 2" means that the encoder assigned by means of "P-0-0078, Assignment optional encoder->optional slot" is used as a control encoder.

See also Functional Description of firmware "Drive Internal Interpolation"

A0109 - Attributes Display: AF
 Ident N°: A0109

7.30 A0110 Velocity synchronization, virtual master axis

Allocation	Contained in 02VRS:	«MPB»	«MPH»	«MPD»	
	Contained in 03VRS:	«MPB»	«MPH»	«MPD»	
	Contained in 04VRS:	«MPB»	«MPH»	«MPD»	
	Contained in 05VRS:	«MPB»	«MPH»	«MPD»	
	Contained in 06VRS:	«MPB»	«MPH»	«MPD»	«MPC»
	Contained in 07VRS:	«MPB»	«MPH»	«MPD»	«MPC»
	Contained in 08VRS:	«MPB»	«MPH»	«MPD»	«MPC»
	Supported by supply unit:	«-»			

The drive is in velocity control. Taking the gear ratio and the master axis position into account, the command velocity is determined in the drive.

"Virtual master axis" means that the master axis position is calculated by the control unit.

See also Functional Description of firmware "Velocity Synchronization with Real/Virtual Master Axis"

A0110 - Attributes Display: AF
 Ident N°: A0110

7.31 A0111 Velocity synchronization, real master axis

Allocation	Contained in 02VRS:	«MPB»	«MPH»	«MPD»	
	Contained in 03VRS:	«MPB»	«MPH»	«MPD»	
	Contained in 04VRS:	«MPB»	«MPH»	«MPD»	
	Contained in 05VRS:	«MPB»	«MPH»	«MPD»	
	Contained in 06VRS:	«MPB»	«MPH»	«MPD»	«MPC»
	Contained in 07VRS:	«MPB»	«MPH»	«MPD»	«MPC»
	Contained in 08VRS:	«MPB»	«MPH»	«MPD»	«MPC»
	Supported by supply unit:	«-»			

The drive is in velocity control. The velocity command value is derived from the master axis position. The master axis position is generated by the measuring encoder.

See also Functional Description of firmware "Velocity Synchronization with Real/Virtual Master Axis"

A0111 - Attributes	Display:	AF
	Ident N°:	A0111

7.32 A0112 Phase synchronization, encoder 1, virtual master axis

Allocation	Contained in 02VRS:	«MPB»	«MPH»	«MPD»	
	Contained in 03VRS:	«MPB»	«MPH»	«MPD»	
	Contained in 04VRS:	«MPB»	«MPH»	«MPD»	
	Contained in 05VRS:	«MPB»	«MPH»	«MPD»	
	Contained in 06VRS:	«MPB»	«MPH»	«MPD»	«MPC»
	Contained in 07VRS:	«MPB»	«MPH»	«MPD»	«MPC»
	Contained in 08VRS:	«MPB»	«MPH»	«MPD»	«MPC»
	Supported by supply unit:	«-»			

The drive is in position control. The position control loop is closed by means of a position encoder in the drive. Taking the gear ratio and the master axis position into account, the position command value is determined in the drive.

The drive follows the command value with a lag distance.

"Encoder 1" means that the position encoder is mounted to the motor shaft (indirect measuring of the axis position). "Virtual master axis" means that the master axis position is calculated by the control unit.

See also Functional Description of firmware "Phase Synchronization with Real/Virtual Master Axis"

A0112 - Attributes	Display:	AF
	Ident N°:	A0112

7.33 A0113 Phase synchronization, encoder 2, virtual master axis

Allocation	Contained in 02VRS:	«MPB»	«MPH»	«MPD»	
	Contained in 03VRS:	«MPB»	«MPH»	«MPD»	
	Contained in 04VRS:	«MPB»	«MPH»	«MPD»	
	Contained in 05VRS:	«MPB»	«MPH»	«MPD»	
	Contained in 06VRS:	«MPB»	«MPH»	«MPD»	«MPC»
	Contained in 07VRS:	«MPB»	«MPH»	«MPD»	«MPC»
	Contained in 08VRS:	«MPB»	«MPH»	«MPD»	«MPC»
	Supported by supply unit:	«-»			

The drive is in position control. The position control loop is closed by means of a position encoder in the drive. Taking the gear ratio and the master axis position into account, the position command value is determined in the drive.

The drive follows the command value with a lag distance.

7.36 A0116 Phase synchr. lagless, encoder 1, virtual master axis

Allocation	Contained in 02VRS:	«MPB»	«MPH»	«MPD»	
	Contained in 03VRS:	«MPB»	«MPH»	«MPD»	
	Contained in 04VRS:	«MPB»	«MPH»	«MPD»	
	Contained in 05VRS:	«MPB»	«MPH»	«MPD»	
	Contained in 06VRS:	«MPB»	«MPH»	«MPD»	«MPC»
	Contained in 07VRS:	«MPB»	«MPH»	«MPD»	«MPC»
	Contained in 08VRS:	«MPB»	«MPH»	«MPD»	«MPC»
	Supported by supply unit:	«-»			

The drive is in position control. The position control loop is closed by means of a position encoder in the drive. Taking the gear ratio and the master axis position into account, the position command value is determined in the drive.

The drive follows the command value without any lag error.

"Encoder 1" means that the position encoder is mounted to the motor shaft (indirect measuring of the axis position). "Virtual master axis" means that the master axis position is calculated by the control unit.

See also Functional Description of firmware "Phase Synchronization with Real/Virtual Master Axis"

A0116 - Attributes	Display:	AF
	Ident N°:	A0116

7.37 A0117 Phase synchr. lagless, encoder 2, virtual master axis

Allocation	Contained in 02VRS:	«MPB»	«MPH»	«MPD»	
	Contained in 03VRS:	«MPB»	«MPH»	«MPD»	
	Contained in 04VRS:	«MPB»	«MPH»	«MPD»	
	Contained in 05VRS:	«MPB»	«MPH»	«MPD»	
	Contained in 06VRS:	«MPB»	«MPH»	«MPD»	«MPC»
	Contained in 07VRS:	«MPB»	«MPH»	«MPD»	«MPC»
	Contained in 08VRS:	«MPB»	«MPH»	«MPD»	«MPC»
	Supported by supply unit:	«-»			

The drive is in position control. The position control loop is closed by means of a position encoder in the drive. Taking the gear ratio and the master axis position into account, the position command value is determined in the drive.

The drive follows the command value without any lag error.

"Encoder 2" means that the position encoder is mounted to the machine axis (direct measuring of the axis position). "Virtual master axis" means that the master axis position is calculated by the control unit.

See also Functional Description of firmware "Phase Synchronization with Real/Virtual Master Axis"

A0117 - Attributes	Display:	AF
	Ident N°:	A0117

7.38 A0118 Phase synchr. lagless, encoder 1, real master axis

Allocation	Contained in 02VRS:	«MPB»	«MPH»	«MPD»	
	Contained in 03VRS:	«MPB»	«MPH»	«MPD»	
	Contained in 04VRS:	«MPB»	«MPH»	«MPD»	
	Contained in 05VRS:	«MPB»	«MPH»	«MPD»	
	Contained in 06VRS:	«MPB»	«MPH»	«MPD»	«MPC»
	Contained in 07VRS:	«MPB»	«MPH»	«MPD»	«MPC»
	Contained in 08VRS:	«MPB»	«MPH»	«MPD»	«MPC»
	Supported by supply unit:	«-»			

7.41 A0129 Cam, encoder 2, virtual master axis

Allocation	Contained in 02VRS:	«MPB»	«MPH»	«MPD»	
	Contained in 03VRS:	«MPB»	«MPH»	«MPD»	
	Contained in 04VRS:	«MPB»	«MPH»	«MPD»	
	Contained in 05VRS:	«MPB»	«MPH»	«MPD»	
	Contained in 06VRS:	«MPB»	«MPH»	«MPD»	«MPC»
	Contained in 07VRS:	«MPB»	«MPH»	«MPD»	«MPC»
	Contained in 08VRS:	«MPB»	«MPH»	«MPD»	«MPC»
	Supported by supply unit:	«-»			

The drive is in the "cam" mode. The function has been derived from the principle of the mechanical cam. There is a fixed position relation between master axis and slave axis. The position command values are taken from a table that is accessed by means of the master axis position.

The drive follows the command value with a lag distance.

"Encoder 2" means that the position encoder is mounted to the machine axis (direct measurement of axis position). "Virtual master axis" means that the master axis position is calculated by the control unit.

See also Functional Description of firmware "Electronic Cam With Real/Virtual Master Axis"

A0129 - Attributes	Display:	AF
	Ident N°:	A0129

7.42 A0130 Cam, encoder 1, real master axis

Allocation	Contained in 02VRS:	«MPB»	«MPH»	«MPD»	
	Contained in 03VRS:	«MPB»	«MPH»	«MPD»	
	Contained in 04VRS:	«MPB»	«MPH»	«MPD»	
	Contained in 05VRS:	«MPB»	«MPH»	«MPD»	
	Contained in 06VRS:	«MPB»	«MPH»	«MPD»	«MPC»
	Contained in 07VRS:	«MPB»	«MPH»	«MPD»	«MPC»
	Contained in 08VRS:	«MPB»	«MPH»	«MPD»	«MPC»
	Supported by supply unit:	«-»			

The drive is in the "cam" mode. The function has been derived from the principle of the mechanical cam. There is a fixed position relation between master axis and slave axis. The position command values are taken from a table that is accessed by means of the master axis position.

The drive follows the command value with a lag distance.

"Encoder 1" means that the position encoder is mounted to the motor shaft (indirect measurement of axis position). "Real master axis" means that the master axis position is derived from the measuring encoder.

See also Functional Description of firmware "Electronic Cam With Real/Virtual Master Axis"

A0130 - Attributes	Display:	AF
	Ident N°:	A0130

7.43 A0131 Cam, encoder 2, real master axis

Allocation	Contained in 02VRS:	«MPB»	«MPH»	«MPD»	
	Contained in 03VRS:	«MPB»	«MPH»	«MPD»	
	Contained in 04VRS:	«MPB»	«MPH»	«MPD»	
	Contained in 05VRS:	«MPB»	«MPH»	«MPD»	
	Contained in 06VRS:	«MPB»	«MPH»	«MPD»	«MPC»
	Contained in 07VRS:	«MPB»	«MPH»	«MPD»	«MPC»
	Contained in 08VRS:	«MPB»	«MPH»	«MPD»	«MPC»
	Supported by supply unit:	«-»			

Diagnostic Status Messages

The drive is in the "cam" mode. The function has been derived from the principle of the mechanical cam. There is a fixed position relation between master axis and slave axis. The position command values are taken from a table that is accessed by means of the master axis position.

The drive follows the command value with a lag distance.

"Encoder 2" means that the position encoder is mounted to the machine axis (direct measurement of axis position). "Real master axis" means that the master axis position is derived from the measuring encoder.

See also Functional Description of firmware "Electronic Cam With Real/Virtual Master Axis"

A0131 - Attributes Display: AF
 Ident N°: A0131

7.44 A0132 Cam, lagless, encoder 1, virt. master axis

Allocation	Contained in 02VRS:	«MPB»	«MPH»	«MPD»	
	Contained in 03VRS:	«MPB»	«MPH»	«MPD»	
	Contained in 04VRS:	«MPB»	«MPH»	«MPD»	
	Contained in 05VRS:	«MPB»	«MPH»	«MPD»	
	Contained in 06VRS:	«MPB»	«MPH»	«MPD»	«MPC»
	Contained in 07VRS:	«MPB»	«MPH»	«MPD»	«MPC»
	Contained in 08VRS:	«MPB»	«MPH»	«MPD»	«MPC»
	Supported by supply unit:	«-»			

The drive is in the "cam" mode. The function has been derived from the principle of the mechanical cam. There is a fixed position relation between master axis and slave axis. The position command values are taken from a table that is accessed by means of the master axis position.

The drive follows the command value without any lag error.

"Encoder 1" means that the position encoder is mounted to the motor shaft (indirect measurement of axis position). "Virtual master axis" means that the master axis position is calculated by the control unit.

See also Functional Description of firmware "Electronic Cam With Real/Virtual Master Axis"

A0132 - Attributes Display: AF
 Ident N°: A0132

7.45 A0133 Cam, lagless, encoder 2, virt. master axis

Allocation	Contained in 02VRS:	«MPB»	«MPH»	«MPD»	
	Contained in 03VRS:	«MPB»	«MPH»	«MPD»	
	Contained in 04VRS:	«MPB»	«MPH»	«MPD»	
	Contained in 05VRS:	«MPB»	«MPH»	«MPD»	
	Contained in 06VRS:	«MPB»	«MPH»	«MPD»	«MPC»
	Contained in 07VRS:	«MPB»	«MPH»	«MPD»	«MPC»
	Contained in 08VRS:	«MPB»	«MPH»	«MPD»	«MPC»
	Supported by supply unit:	«-»			

The drive is in the "cam" mode. The function has been derived from the principle of the mechanical cam. There is a fixed position relation between master axis and slave axis. The position command values are taken from a table that is accessed by means of the master axis position.

The drive follows the command value without any lag error.

"Encoder 2" means that the position encoder is mounted to the machine axis (direct measurement of axis position). "Virtual master axis" means that the master axis position is calculated by the control unit.

Diagnostic Status Messages

7.48 A0136 MotionProfile, encoder 1, virtual master axis

Allocation	Contained in 02VRS:	«-»	«-»	«-»	
	Contained in 03VRS:	«-»	«MPH»	«-»	
	Contained in 04VRS:	«MPB»	«MPH»	«MPD»	
	Contained in 05VRS:	«MPB»	«MPH»	«MPD»	
	Contained in 06VRS:	«MPB»	«MPH»	«MPD»	«MPC»
	Contained in 07VRS:	«MPB»	«MPH»	«MPD»	«MPC»
	Contained in 08VRS:	«MPB»	«MPH»	«MPD»	«MPC»
	Supported by supply unit:	«-»			



Up to firmware version MPx05, the name of this diagnostic status message was "A0136 Motion profile, encoder 1, virtual master axis".

The drive is in the "MotionProfile" mode. The function has been derived from the principle of the mechanical cam. There is a fixed position relation between master axis and slave axis. Depending on the master axis position, the position command values are generated from a given motion profile.

The drive follows the command value with a lag distance.

"Encoder 1" means that the position encoder is mounted to the motor shaft (indirect measurement of axis position). "Virtual master axis" means that the master axis position is calculated by the control unit.

See also Functional Description of firmware "MotionProfile With Real/Virtual Master Axis"

A0136 - Attributes	Display:	AF
	Ident N°:	A0136

7.49 A0137 MotionProfile, encoder 2, virtual master axis

Allocation	Contained in 02VRS:	«-»	«-»	«-»	
	Contained in 03VRS:	«-»	«MPH»	«-»	
	Contained in 04VRS:	«MPB»	«MPH»	«MPD»	
	Contained in 05VRS:	«MPB»	«MPH»	«MPD»	
	Contained in 06VRS:	«MPB»	«MPH»	«MPD»	«MPC»
	Contained in 07VRS:	«MPB»	«MPH»	«MPD»	«MPC»
	Contained in 08VRS:	«MPB»	«MPH»	«MPD»	«MPC»
	Supported by supply unit:	«-»			



Up to firmware version MPx05, the name of this diagnostic status message was "A0137 Motion profile, encoder 2, virtual master axis".

The drive is in the "MotionProfile" mode. The function has been derived from the principle of the mechanical cam. There is a fixed position relation between master axis and slave axis. Depending on the master axis position, the position command values are generated from a given motion profile.

The drive follows the command value with a lag distance.

"Encoder 2" means that the position encoder is mounted to the machine axis (direct measurement of axis position). "Virtual master axis" means that the master axis position is calculated by the control unit.

See also Functional Description of firmware "MotionProfile With Real/Virtual Master Axis"

A0137 - Attributes	Display:	AF
	Ident N°:	A0137

7.50 A0138 MotionProfile, encoder 2, real master axis

Allocation	Contained in 02VRS:	«-»	«-»	«-»	
	Contained in 03VRS:	«-»	«MPH»	«-»	
	Contained in 04VRS:	«MPB»	«MPH»	«MPD»	
	Contained in 05VRS:	«MPB»	«MPH»	«MPD»	
	Contained in 06VRS:	«MPB»	«MPH»	«MPD»	«MPC»
	Contained in 07VRS:	«MPB»	«MPH»	«MPD»	«MPC»
	Contained in 08VRS:	«MPB»	«MPH»	«MPD»	«MPC»
	Supported by supply unit:	«-»			



Up to firmware version MPx05, the name of this diagnostic status message was "A0138 Motion profile, encoder 2, real master axis".

The drive is in the "MotionProfile" mode. The function has been derived from the principle of the mechanical cam. There is a fixed position relation between master axis and slave axis. Depending on the master axis position, the position command values are generated from a given motion profile.

The drive follows the command value with a lag distance.

"Encoder 2" means that the position encoder is mounted to the machine axis (direct measurement of axis position). "Real master axis" means that the master axis position is derived from the measuring encoder.

See also Functional Description of firmware "MotionProfile With Real/Virtual Master Axis"

A0138 - Attributes	Display:	AF
	Ident N°:	A0138

7.51 A0139 MotionProfile, encoder 1, real master axis

Allocation	Contained in 02VRS:	«-»	«-»	«-»	
	Contained in 03VRS:	«-»	«MPH»	«-»	
	Contained in 04VRS:	«MPB»	«MPH»	«MPD»	
	Contained in 05VRS:	«MPB»	«MPH»	«MPD»	
	Contained in 06VRS:	«MPB»	«MPH»	«MPD»	«MPC»
	Contained in 07VRS:	«MPB»	«MPH»	«MPD»	«MPC»
	Contained in 08VRS:	«MPB»	«MPH»	«MPD»	«MPC»
	Supported by supply unit:	«-»			



Up to firmware version MPx05, the name of this diagnostic status message was "A0139 Motion profile, encoder 1, real master axis".

The drive is in the "MotionProfile" mode. The function has been derived from the principle of the mechanical cam. There is a fixed position relation between master axis and slave axis. Depending on the master axis position, the position command values are generated from a given motion profile.

The drive follows the command value with a lag distance.

"Encoder 1" means that the position encoder is mounted to the motor shaft (indirect measurement of axis position). "Real master axis" means that the master axis position is derived from the measuring encoder.

See also Functional Description of firmware "MotionProfile With Real/Virtual Master Axis"

A0139 - Attributes	Display:	AF
	Ident N°:	A0139

Diagnostic Status Messages

7.52 A0140 MotionProfile lagless, encoder 1, virtual master axis

Allocation	Contained in 02VRS:	«-»	«-»	«-»	
	Contained in 03VRS:	«-»	«MPH»	«-»	
	Contained in 04VRS:	«MPB»	«MPH»	«MPD»	
	Contained in 05VRS:	«MPB»	«MPH»	«MPD»	
	Contained in 06VRS:	«MPB»	«MPH»	«MPD»	«MPC»
	Contained in 07VRS:	«MPB»	«MPH»	«MPD»	«MPC»
	Contained in 08VRS:	«MPB»	«MPH»	«MPD»	«MPC»
	Supported by supply unit:	«-»			



Up to firmware version MPx05, the name of this diagnostic status message was "A0140 Motion profile lagless, encoder 1, virtual master axis".

The drive is in the "MotionProfile" mode. The function has been derived from the principle of the mechanical cam. There is a fixed position relation between master axis and slave axis. Depending on the master axis position, the position command values are generated from a given motion profile.

The drive follows the command value without any lag error.

"Encoder 1" means that the position encoder is mounted to the motor shaft (indirect measurement of axis position). "Virtual master axis" means that the master axis position is calculated by the control unit.

See also Functional Description of firmware "MotionProfile With Real/Virtual Master Axis"

A0140 - Attributes	Display:	AF
	Ident N°:	A0140

7.53 A0141 MotionProfile lagless, encoder 2, virtual master axis

Allocation	Contained in 02VRS:	«-»	«-»	«-»	
	Contained in 03VRS:	«-»	«MPH»	«-»	
	Contained in 04VRS:	«MPB»	«MPH»	«MPD»	
	Contained in 05VRS:	«MPB»	«MPH»	«MPD»	
	Contained in 06VRS:	«MPB»	«MPH»	«MPD»	«MPC»
	Contained in 07VRS:	«MPB»	«MPH»	«MPD»	«MPC»
	Contained in 08VRS:	«MPB»	«MPH»	«MPD»	«MPC»
	Supported by supply unit:	«-»			



Up to firmware version MPx05, the name of this diagnostic status message was "A0141 Motion profile lagless, encoder 2, virtual master axis".

The drive is in the "MotionProfile" mode. The function has been derived from the principle of the mechanical cam. There is a fixed position relation between master axis and slave axis. Depending on the master axis position, the position command values are generated from a given motion profile.

The drive follows the command value without any lag error.

"Encoder 2" means that the position encoder is mounted to the machine axis (direct measurement of axis position). "Virtual master axis" means that the master axis position is calculated by the control unit.

See also Functional Description of firmware "MotionProfile With Real/Virtual Master Axis"

A0141 - Attributes	Display:	AF
	Ident N°:	A0141

7.54 A0142 MotionProfile lagless, encoder 1, real master axis

Allocation	Contained in 02VRS:	«-»	«-»	«-»	
	Contained in 03VRS:	«-»	«MPH»	«-»	
	Contained in 04VRS:	«MPB»	«MPH»	«MPD»	
	Contained in 05VRS:	«MPB»	«MPH»	«MPD»	
	Contained in 06VRS:	«MPB»	«MPH»	«MPD»	«MPC»
	Contained in 07VRS:	«MPB»	«MPH»	«MPD»	«MPC»
	Contained in 08VRS:	«MPB»	«MPH»	«MPD»	«MPC»
	Supported by supply unit:	«-»			



Up to firmware version MPx05, the name of this diagnostic status message was "A0142 Motion profile lagless, encoder 1, real master axis".

The drive is in the "MotionProfile" mode. The function has been derived from the principle of the mechanical cam. There is a fixed position relation between master axis and slave axis. Depending on the master axis position, the position command values are generated from a given motion profile.

The drive follows the command value without any lag error.

"Encoder 1" means that the position encoder is mounted to the motor shaft (indirect measurement of axis position). "Real master axis" means that the master axis position is derived from the incremental encoder signals.

See also Functional Description of firmware "MotionProfile With Real/Virtual Master Axis"

A0142 - Attributes	Display:	AF
	Ident N°:	A0142

7.55 A0143 MotionProfile lagless, encoder 2, real master axis

Allocation	Contained in 02VRS:	«-»	«-»	«-»	
	Contained in 03VRS:	«-»	«MPH»	«-»	
	Contained in 04VRS:	«MPB»	«MPH»	«MPD»	
	Contained in 05VRS:	«MPB»	«MPH»	«MPD»	
	Contained in 06VRS:	«MPB»	«MPH»	«MPD»	«MPC»
	Contained in 07VRS:	«MPB»	«MPH»	«MPD»	«MPC»
	Contained in 08VRS:	«MPB»	«MPH»	«MPD»	«MPC»
	Supported by supply unit:	«-»			



Up to firmware version MPx05, the name of this diagnostic status message was "Motion profile lagless, encoder 2, real master axis".

The drive is in the "MotionProfile" mode. The function has been derived from the principle of the mechanical cam. There is a fixed position relation between master axis and slave axis. Depending on the master axis position, the position command values are generated from a given motion profile.

The drive follows the command value without any lag error.

"Encoder 2" means that the position encoder is mounted to the machine axis (direct measurement of axis position). "Real master axis" means that the master axis position is derived from the measuring encoder.

See also Functional Description of firmware "MotionProfile With Real/Virtual Master Axis"

A0143 - Attributes	Display:	AF
	Ident N°:	A0143

Diagnostic Status Messages

7.56 A0150 Drive-controlled positioning, encoder 1

Allocation	Contained in 02VRS:	«MPB»	«MPH»	«MPD»	
	Contained in 03VRS:	«MPB»	«MPH»	«MPD»	
	Contained in 04VRS:	«MPB»	«MPH»	«MPD»	
	Contained in 05VRS:	«MPB»	«MPH»	«MPD»	
	Contained in 06VRS:	«MPB»	«MPH»	«MPD»	«MPC»
	Contained in 07VRS:	«MPB»	«MPH»	«MPD»	«MPC»
	Contained in 08VRS:	«MPB»	«MPH»	«MPD»	«MPC»
	Supported by supply unit:	«-»			

From the master the drive receives a position command value in the "S-0-0282, Positioning command value" parameter. This position/distance, when the status of bit 0 of parameter "S-0-0346, Positioning command strobe" changes, is copied to "S-0-0258, Target position" or, in the case of a relative input, added to the value in "S-0-0430, Effective target position". The drive then generates (interpolates) an internal position command value characteristic in order to get from the current position to this target position. This is done considering the limit values for velocity, acceleration and jerk in the following parameters:

- "S-0-0193, Positioning Jerk",
- "S-0-0259, Positioning Velocity",
- "S-0-0260, Positioning Acceleration" and
- "S-0-0359, Positioning Deceleration".

With a lag error proportional to the velocity the drive moves to the target position.

"Encoder 1" means that the encoder assigned by means of "P-0-0077, Assignment motor encoder->optional slot" is used as a control encoder.

See also Functional Description of firmware "Drive Controlled Positioning"

A0150 - Attributes	Display:	AF
	Ident N°:	A0150

7.57 A0151 Drive-controlled positioning, encoder 1, lagless

Allocation	Contained in 02VRS:	«MPB»	«MPH»	«MPD»	
	Contained in 03VRS:	«MPB»	«MPH»	«MPD»	
	Contained in 04VRS:	«MPB»	«MPH»	«MPD»	
	Contained in 05VRS:	«MPB»	«MPH»	«MPD»	
	Contained in 06VRS:	«MPB»	«MPH»	«MPD»	«MPC»
	Contained in 07VRS:	«MPB»	«MPH»	«MPD»	«MPC»
	Contained in 08VRS:	«MPB»	«MPH»	«MPD»	«MPC»
	Supported by supply unit:	«-»			

From the master the drive receives a position command value in the "S-0-0282, Positioning command value" parameter. This distance, when the status of bit 0 of parameter "S-0-0346, Positioning command strobe" changes, is copied to "S-0-0430, Effective target position" or, in the case of a relative input, added to the value in S-0-0430, Effective target position". The drive then generates (interpolates) an internal position command value characteristic in order to get from the current position to this target position. This is done considering the limit values for velocity, acceleration and jerk in the following parameters:

- "S-0-0259, Positioning Velocity",
- "S-0-0260, Positioning Acceleration",
- "S-0-0359, Positioning Deceleration" and
- "S-0-0193, Positioning Jerk".

Diagnostic Status Messages

The drive laglessly moves to the target position (prerequisite: "P-0-0040, Velocity feedforward evaluation"=100%).

"Encoder 1" means that the encoder assigned by means of "P-0-0077, Assignment motor encoder->optional slot" is used as a control encoder.

See also Functional Description of firmware "Drive Controlled Positioning"

A0151 - Attributes Display: AF
 Ident N°: A0151

7.58 A0152 Drive-controlled positioning, encoder 2

Allocation	Contained in 02VRS:	«MPB»	«MPH»	«MPD»	
	Contained in 03VRS:	«MPB»	«MPH»	«MPD»	
	Contained in 04VRS:	«MPB»	«MPH»	«MPD»	
	Contained in 05VRS:	«MPB»	«MPH»	«MPD»	
	Contained in 06VRS:	«MPB»	«MPH»	«MPD»	«MPC»
	Contained in 07VRS:	«MPB»	«MPH»	«MPD»	«MPC»
	Contained in 08VRS:	«MPB»	«MPH»	«MPD»	«MPC»
	Supported by supply unit:	«-»			

From the master the drive receives a position command value in the "S-0-0282, Positioning command value" parameter. This distance, when the status of bit 0 of parameter "S-0-0346, Positioning command strobe" changes, is copied to "S-0-0430, Effective target position" or, in the case of a relative input, added to the value in "S-0-0430, Effective target position". The drive then generates (interpolates) an internal position command value characteristic in order to get from the current position to this target position. This is done considering the limit values for velocity, acceleration and jerk in the following parameters:

- "S-0-0259, Positioning Velocity",
- "S-0-0260, Positioning Acceleration",
- "S-0-0359, Positioning Deceleration" and
- "S-0-0193, Positioning Jerk".

With a lag error proportional to the velocity the drive moves to the target position.

"Encoder 2" means that the encoder assigned by means of "P-0-0078, Assignment optional encoder->optional slot" is used as a control encoder.

See also Functional Description of firmware "Drive Controlled Positioning"

A0152 - Attributes Display: AF
 Ident N°: A0152

7.59 A0153 Drive-controlled positioning, encoder 2, lagless

Allocation	Contained in 02VRS:	«MPB»	«MPH»	«MPD»	
	Contained in 03VRS:	«MPB»	«MPH»	«MPD»	
	Contained in 04VRS:	«MPB»	«MPH»	«MPD»	
	Contained in 05VRS:	«MPB»	«MPH»	«MPD»	
	Contained in 06VRS:	«MPB»	«MPH»	«MPD»	«MPC»
	Contained in 07VRS:	«MPB»	«MPH»	«MPD»	«MPC»
	Contained in 08VRS:	«MPB»	«MPH»	«MPD»	«MPC»
	Supported by supply unit:	«-»			

From the master the drive receives a position command value in the "S-0-0282, Positioning command value" parameter. This distance, when the status of bit 0 of parameter "S-0-0346, Positioning command strobe" changes, is copied to "S-0-0430, Effective target position" or, in the case of a relative input, added to the value in "S-0-0430, Effective target position". The

Diagnostic Status Messages

drive then generates (interpolates) an internal position command value characteristic in order to get from the current position to this target position. This is done considering the limit values for velocity, acceleration and jerk in the following parameters:

- "S-0-0259, Positioning Velocity",
- "S-0-0260, Positioning Acceleration",
- "S-0-0359, Positioning Deceleration" and
- "S-0-0193, Positioning Jerk".

The drive laglessly moves to the target position (prerequisite: "P-0-0040, Velocity feedforward evaluation"=100%).

"Encoder 2" means that the encoder assigned by means of "P-0-0078, Assignment optional encoder->optional slot" is used as a control encoder.

See also Functional Description of firmware "Drive Controlled Positioning"

A0153 - Attributes Display: AF
 Ident N°: A0153

7.60 A0154 Position mode drive controlled, encoder 1

Allocation	Contained in 02VRS:	«MPB»	«MPH»	«MPD»	
	Contained in 03VRS:	«MPB»	«MPH»	«MPD»	
	Contained in 04VRS:	«MPB»	«MPH»	«MPD»	
	Contained in 05VRS:	«MPB»	«MPH»	«MPD»	
	Contained in 06VRS:	«MPB»	«MPH»	«MPD»	«MPC»
	Contained in 07VRS:	«MPB»	«MPH»	«MPD»	«MPC»
	Contained in 08VRS:	«MPB»	«MPH»	«MPD»	«MPC»
	Supported by supply unit:	«-»			

The drive is in position control. The position control loop is closed in the drive by means of a position encoder. The master only presets the position command value characteristic.

When the operation mode is activated, any possible difference between current actual position value and transmitted position command value is traveled in drive-controlled form **with a lag error**.

"Encoder 1" means that the encoder assigned via "P-0-0077, Assignment motor encoder->optional slot" is used as control encoder.

See also Functional Description of firmware "Position Control With Cyclic Command Value Input"

A0154 - Attributes Display: AF
 Ident N°: A0154

7.61 A0155 Position mode drive controlled, encoder 2

Allocation	Contained in 02VRS:	«MPB»	«MPH»	«MPD»	
	Contained in 03VRS:	«MPB»	«MPH»	«MPD»	
	Contained in 04VRS:	«MPB»	«MPH»	«MPD»	
	Contained in 05VRS:	«MPB»	«MPH»	«MPD»	
	Contained in 06VRS:	«MPB»	«MPH»	«MPD»	«MPC»
	Contained in 07VRS:	«MPB»	«MPH»	«MPD»	«MPC»
	Contained in 08VRS:	«MPB»	«MPH»	«MPD»	«MPC»
	Supported by supply unit:	«-»			

The drive is in position control. The position control loop is closed in the drive by means of a position encoder. The master only presets the position command value characteristic.

Diagnostic Status Messages

When the operation mode is activated, any possible difference between current actual position value and transmitted position command value is traveled in drive-controlled form **with a lag error**.

"Encoder 2" means that the encoder assigned via "P-0-0078, Assignment optional encoder->optional slot" is used as control encoder.

See also Functional Description of firmware "Position Control With Cyclic Command Value Input"

A0155 - Attributes Display: AF
 Ident N°: A0155

7.62 A0156 Position mode lagless, encoder 1 drive controlled

Allocation	Contained in 02VRS:	«MPB»	«MPH»	«MPD»	
	Contained in 03VRS:	«MPB»	«MPH»	«MPD»	
	Contained in 04VRS:	«MPB»	«MPH»	«MPD»	
	Contained in 05VRS:	«MPB»	«MPH»	«MPD»	
	Contained in 06VRS:	«MPB»	«MPH»	«MPD»	«MPC»
	Contained in 07VRS:	«MPB»	«MPH»	«MPD»	«MPC»
	Contained in 08VRS:	«MPB»	«MPH»	«MPD»	«MPC»
	Supported by supply unit:	«-»			

The drive is in position control. The position control loop is closed in the drive by means of a position encoder. The master only presets the position command value characteristic.

When the operation mode is activated, any possible difference between current actual position value and transmitted position command value is traveled in drive-controlled form **without lag error**.

"Encoder 1" means that the encoder assigned via "P-0-0077, Assignment motor encoder->optional slot" is used as control encoder.

See also Functional Description of firmware "Position Control With Cyclic Command Value Input"

A0156 - Attributes Display: AF
 Ident N°: A0156

7.63 A0157 Position mode lagless, encoder 2 drive controlled

Allocation	Contained in 02VRS:	«MPB»	«MPH»	«MPD»	
	Contained in 03VRS:	«MPB»	«MPH»	«MPD»	
	Contained in 04VRS:	«MPB»	«MPH»	«MPD»	
	Contained in 05VRS:	«MPB»	«MPH»	«MPD»	
	Contained in 06VRS:	«MPB»	«MPH»	«MPD»	«MPC»
	Contained in 07VRS:	«MPB»	«MPH»	«MPD»	«MPC»
	Contained in 08VRS:	«MPB»	«MPH»	«MPD»	«MPC»
	Supported by supply unit:	«-»			

The drive is in position control. The position control loop is closed in the drive by means of a position encoder. The master only presets the position command value characteristic.

When the operation mode is activated, any possible difference between current actual position value and transmitted position command value is traveled in drive-controlled form **without lag error**.

"Encoder 2" means that the encoder assigned via "P-0-0078, Assignment optional encoder->optional slot" is used as control encoder.

See also Functional Description of firmware "Position Control With Cyclic Command Value Input"

Diagnostic Status Messages

A0157 - Attributes **Display:** AF
Ident N°: A0157

7.64 A0160 Position mode drive controlled

Allocation	Contained in 02VRS:	«-»	«-»	«-»	
	Contained in 03VRS:	«-»	«-»	«-»	
	Contained in 04VRS:	«MPB»	«MPH»	«MPD»	
	Contained in 05VRS:	«MPB»	«MPH»	«MPD»	
	Contained in 06VRS:	«MPB»	«MPH»	«MPD»	«MPC»
	Contained in 07VRS:	«MPB»	«MPH»	«MPD»	«MPC»
	Contained in 08VRS:	«MPB»	«MPH»	«MPD»	«MPC»
	Supported by supply unit:	«-»			

The drive is in position control. The position control loop is closed in the drive by means of a position encoder. The master only presets the position command value characteristic.

When the operation mode is activated, any possible difference between current actual position value and transmitted position command value is traveled in drive-controlled form.

According to the axis controller control word (S-0-0520), the drive controls with encoder 1 or encoder 2, laglessly or with lag error, with regard to the target position to be approached (prerequisite: "P-0-0040, Velocity feedforward evaluation"=100%).



Control with encoder 2 can only take place if encoder 2 is available.

See also Functional Description of firmware "Position Control With Cyclic Command Value Input"

A0160 - Attributes **Display:** AF
Ident N°: A0160

7.65 A0161 Drive-controlled positioning

Allocation	Contained in 02VRS:	«-»	«-»	«-»	
	Contained in 03VRS:	«-»	«-»	«-»	
	Contained in 04VRS:	«MPB»	«MPH»	«MPD»	
	Contained in 05VRS:	«MPB»	«MPH»	«MPD»	
	Contained in 06VRS:	«MPB»	«MPH»	«MPD»	«MPC»
	Contained in 07VRS:	«MPB»	«MPH»	«MPD»	«MPC»
	Contained in 08VRS:	«MPB»	«MPH»	«MPD»	«MPC»
	Supported by supply unit:	«-»			

From the master the drive receives a position command value in parameter "S-0-0282, Positioning command value". This distance, when the status of bit 0 of parameter "S-0-0346, Positioning command strobe" changes, is copied to the value in "S-0-0430, Effective target position" or, in the case of relative input, added to this value. The drive then generates (interpolates) an internal position command value characteristic in order to get from the current position to this target position. This is done considering the parameterized values for velocity, acceleration and jerk in the parameters

- "S-0-0259, Positioning Velocity",
- "S-0-0260, Positioning Acceleration",
- "S-0-0359, Positioning Deceleration" and
- "S-0-0193, Positioning Jerk".

Diagnostic Status Messages

According to the axis controller control word, the drive controls with encoder 1 or encoder 2, laglessly or with lag error, with regard to the target position to be approached (prerequisite: "P-0-0040, Velocity feedforward evaluation"=100%).



Control with encoder 2 can only take place if encoder 2 is available.

See also Functional Description of firmware "Drive-Controlled Positioning"

A0161 - Attributes Display: AF
 Ident N°: A0161

7.66 A0162 Positioning block mode

Allocation	Contained in 02VRS:	«-»	«-»	«-»	
	Contained in 03VRS:	«-»	«-»	«-»	
	Contained in 04VRS:	«MPB»	«MPH»	«MPD»	
	Contained in 05VRS:	«MPB»	«MPH»	«MPD»	
	Contained in 06VRS:	«MPB»	«MPH»	«MPD»	«MPC»
	Contained in 07VRS:	«MPB»	«MPH»	«MPD»	«MPC»
	Contained in 08VRS:	«MPB»	«MPH»	«MPD»	«MPC»
	Supported by supply unit:	«-»			

The command value profile is generated in the drive. Target position, velocity, acceleration and jerk are determined by a programmed positioning block. According to the parameterization of "P-0-4019, Positioning block mode", the target position is understood as an absolute or relative distance.

According to the axis controller control word, the drive controls with encoder 1 or encoder 2, laglessly or with lag error, with regard to the target position to be approached (prerequisite: "P-0-0040, Velocity feedforward evaluation"=100%).



Control with encoder 2 can only take place if encoder 2 is available.

See also Functional Description of firmware "Positioning Block Mode"

A0162 - Attributes Display: AF
 Ident N°: A0162

7.67 A0163 Position synchronization

Allocation	Contained in 02VRS:	«-»	«-»	«-»	
	Contained in 03VRS:	«-»	«-»	«-»	
	Contained in 04VRS:	«MPB»	«MPH»	«MPD»	
	Contained in 05VRS:	«MPB»	«MPH»	«MPD»	
	Contained in 06VRS:	«MPB»	«MPH»	«MPD»	«MPC»
	Contained in 07VRS:	«MPB»	«MPH»	«MPD»	«MPC»
	Contained in 08VRS:	«MPB»	«MPH»	«MPD»	«MPC»
	Supported by supply unit:	«-»			

The drive is in the "Position synchronization" mode. This means that the drive is in position control and the position command values are derived from master axis positions.

See also Functional Description of firmware "Synchronization Modes"

A0163 - Attributes Display: AF
 Ident N°: A0163

Diagnostic Status Messages

7.68 A0164 Velocity synchronization

Allocation	Contained in 02VRS:	«-»	«-»	«-»	
	Contained in 03VRS:	«-»	«-»	«-»	
	Contained in 04VRS:	«MPB»	«MPH»	«MPD»	
	Contained in 05VRS:	«MPB»	«MPH»	«MPD»	
	Contained in 06VRS:	«MPB»	«MPH»	«MPD»	«MPC»
	Contained in 07VRS:	«MPB»	«MPH»	«MPD»	«MPC»
	Contained in 08VRS:	«MPB»	«MPH»	«MPD»	«MPC»
	Supported by supply unit:	«-»			

The drive is in the "Velocity synchronization" mode. This means that the drive is in velocity control and the velocity command values are derived from master axis positions.

See also Functional Description of firmware "Synchronization Modes"

A0164 - Attributes	Display:	AF
	Ident N°:	A0164

7.69 A0206 Positioning block mode, encoder 1

Allocation	Contained in 02VRS:	«MPB»	«MPH»	«MPD»	
	Contained in 03VRS:	«MPB»	«MPH»	«MPD»	
	Contained in 04VRS:	«MPB»	«MPH»	«MPD»	
	Contained in 05VRS:	«MPB»	«MPH»	«MPD»	
	Contained in 06VRS:	«MPB»	«MPH»	«MPD»	«MPC»
	Contained in 07VRS:	«MPB»	«MPH»	«MPD»	«MPC»
	Contained in 08VRS:	«MPB»	«MPH»	«MPD»	«MPC»
	Supported by supply unit:	«-»			

The drive is in position control with systematic lag distance. Encoder 1 (motor encoder) provides the actual value. The command value profile is generated in the drive. Target position, velocity, acceleration and jerk are determined by a previously programmed positioning block. According to the parameterization of "P-0-4019, Positioning block mode", the target position shall be understood as being absolute or as relative distance.

See also Functional Description of firmware "Positioning Block Mode"

A0206 - Attributes	Display:	AF
	Ident N°:	A0206

7.70 A0207 Positioning block mode lagless, encoder 1

Allocation	Contained in 02VRS:	«MPB»	«MPH»	«MPD»	
	Contained in 03VRS:	«MPB»	«MPH»	«MPD»	
	Contained in 04VRS:	«MPB»	«MPH»	«MPD»	
	Contained in 05VRS:	«MPB»	«MPH»	«MPD»	
	Contained in 06VRS:	«MPB»	«MPH»	«MPD»	«MPC»
	Contained in 07VRS:	«MPB»	«MPH»	«MPD»	«MPC»
	Contained in 08VRS:	«MPB»	«MPH»	«MPD»	«MPC»
	Supported by supply unit:	«-»			

The drive is in position control without lag distance. Encoder 1 (motor encoder) provides the actual value. The command value profile is generated in the drive. Target position, velocity, acceleration and jerk are determined by a previously programmed positioning block. According to the parameterization of "P-0-4019, Positioning block mode", the target position shall be understood as being absolute or as relative distance.

See also Functional Description of firmware "Positioning Block Mode"

A0207 - Attributes	Display:	AF
	Ident N°:	A0207

7.71 A0210 Positioning block mode, encoder 2

Allocation	Contained in 02VRS:	«MPB»	«MPH»	«MPD»	
	Contained in 03VRS:	«MPB»	«MPH»	«MPD»	
	Contained in 04VRS:	«MPB»	«MPH»	«MPD»	
	Contained in 05VRS:	«MPB»	«MPH»	«MPD»	
	Contained in 06VRS:	«MPB»	«MPH»	«MPD»	«MPC»
	Contained in 07VRS:	«MPB»	«MPH»	«MPD»	«MPC»
	Contained in 08VRS:	«MPB»	«MPH»	«MPD»	«MPC»
	Supported by supply unit:	«-»			

The drive is in position control with systematic lag distance. Encoder 2 provides the actual value. The command value profile is generated in the drive. Target position, velocity, acceleration and jerk are determined by a previously programmed positioning block. According to the parameterization of "P-0-4019, Positioning block mode", the target position shall be understood as being absolute or as relative distance.

See also Functional Description of firmware "Positioning Block Mode"

A0210 - Attributes	Display:	AF
	Ident N°:	A0210

7.72 A0211 Positioning block mode lagless, encoder 2

Allocation	Contained in 02VRS:	«MPB»	«MPH»	«MPD»	
	Contained in 03VRS:	«MPB»	«MPH»	«MPD»	
	Contained in 04VRS:	«MPB»	«MPH»	«MPD»	
	Contained in 05VRS:	«MPB»	«MPH»	«MPD»	
	Contained in 06VRS:	«MPB»	«MPH»	«MPD»	«MPC»
	Contained in 07VRS:	«MPB»	«MPH»	«MPD»	«MPC»
	Contained in 08VRS:	«MPB»	«MPH»	«MPD»	«MPC»
	Supported by supply unit:	«-»			

The drive is in position control without lag distance. Encoder 2 provides the actual value. The command value profile is generated in the drive. Target position, velocity, acceleration and jerk are determined by a previously programmed positioning block. According to the parameterization of "P-0-4019, Positioning block mode", the target position shall be understood as being absolute or as relative distance.

See also Functional Description of firmware "Positioning Block Mode"

A0211 - Attributes	Display:	AF
	Ident N°:	A0211

7.73 A0403 Quick stop with probe detection is active

Allocation	Contained in 02VRS:	«-»	«-»	«-»	
	Contained in 03VRS:	«-»	«-»	«-»	
	Contained in 04VRS:	«-»	«-»	«-»	
	Contained in 05VRS:	«MPB»	«MPH»	«MPD»	
	Contained in 06VRS:	«MPB»	«MPH»	«MPD»	«MPC»
	Contained in 07VRS:	«MPB»	«MPH»	«MPD»	«MPC»
	Contained in 08VRS:	«MPB»	«MPH»	«MPD»	«MPC»
	Supported by supply unit:	«-»			

The readiness for quick stop and the detection of the quick stop signal internally trigger the speed command value reset which causes the axis to be shut down. This happens taking the following values into account:

- the current torque/force limit value for drives in closed-loop operation
- the maximum stator frequency change (P-0-0569) for drives in open-loop operation

Diagnostic Status Messages

In the case of quick stop, the drive ignores the setting of command values by the control master, decelerates in a drive-controlled way and remains in a drive-internal operating mode until the readiness for quick stop is reset.

See also Functional Description of firmware "Quick Stop via Probe Input"

A0403 - Attributes Display: AR
 Ident N°: A0403

7.74 A0500 Supply module in voltage control

Allocation	Contained in 02VRS:	«-»	«-»	«-»	
	Contained in 03VRS:	«-»	«-»	«-»	
	Contained in 04VRS:	«-»	«-»	«-»	
	Contained in 05VRS:	«-»	«-»	«-»	
	Contained in 06VRS:	«-»	«-»	«-»	«-»
	Contained in 07VRS:	«-»	«-»	«-»	«-»
	Contained in 08VRS:	«-»	«-»	«-»	«-»
	Supported by supply unit:	«H MV»			

The mains contactor has been switched in, the DC bus has been charged, the DC bus voltage is regulated to 750 V direct voltage.



On the display of Rexroth IndraDrive supply units, the text "VM" ("Versorgungs-Modul" = supply module) precedes the diagnostic message.

A0500 - Attributes Display: A0500
 Ident N°: A0500

7.75 A0502 Supply module in operation

Allocation	Contained in 02VRS:	«-»	«-»	«-»	
	Contained in 03VRS:	«-»	«-»	«-»	
	Contained in 04VRS:	«-»	«-»	«-»	
	Contained in 05VRS:	«-»	«-»	«-»	
	Contained in 06VRS:	«-»	«-»	«-»	«-»
	Contained in 07VRS:	«-»	«-»	«-»	«-»
	Contained in 08VRS:	«-»	«-»	«-»	«-»
	Supported by supply unit:	«H MV»			

The mains contactor has been switched in, the DC bus has been charged and is ready for power output.



On the display of Rexroth IndraDrive supply units, the text "VM" ("Versorgungs-Modul" = supply module) precedes the diagnostic message.

A0502 - Attributes Display: A0502
 Ident N°: A0502

7.76 A0503 DC bus charging active

Allocation	Contained in 02VRS:	«-»	«-»	«-»	
	Contained in 03VRS:	«-»	«-»	«-»	
	Contained in 04VRS:	«-»	«-»	«-»	
	Contained in 05VRS:	«-»	«-»	«-»	
	Contained in 06VRS:	«-»	«-»	«-»	«-»
	Contained in 07VRS:	«-»	«-»	«-»	«-»
	Contained in 08VRS:	«-»	«-»	«-»	«-»
	Supported by supply unit:	«H MV»			

Diagnostic Status Messages

The DC bus is presently charged to the crest value of the mains voltage ("soft start"). When the voltage in the DC bus has reached the crest value of the mains voltage, the mains contactor is switched in.



On the display of Rexroth IndraDrive supply units, the text "VM" ("Versorgungs-Modul" = supply module) precedes the diagnostic message.

A0503 - Attributes Display:
 Ident N°: A0503

7.77 A0520 DC bus quick discharge active

Allocation	Contained in 02VRS:	«-»	«-»	«-»	
	Contained in 03VRS:	«-»	«-»	«-»	
	Contained in 04VRS:	«-»	«-»	«-»	
	Contained in 05VRS:	«-»	«-»	«-»	
	Contained in 06VRS:	«-»	«-»	«-»	«-»
	Contained in 07VRS:	«-»	«-»	«-»	«-»
	Contained in 08VRS:	«-»	«-»	«-»	«-»
	Supported by supply unit:	«H MV»			

The braking resistor is presently short-circuiting the DC bus in order to reduce the DC bus voltage as quickly as possible.



The "DC bus short circuit" function (ZKS) was activated via the terminal strip X32 at the HMV.



On the display of Rexroth IndraDrive supply units, the text "VM" ("Versorgungs-Modul" = supply module) precedes the diagnostic message.

A0520 - Attributes Display:
 Ident N°: A0520

7.78 A0800 Unknown operating mode

Allocation	Contained in 02VRS:	«-»	«-»	«-»	
	Contained in 03VRS:	«-»	«-»	«-»	
	Contained in 04VRS:	«-»	«-»	«-»	
	Contained in 05VRS:	«-»	«-»	«-»	
	Contained in 06VRS:	«-»	«-»	«-»	«-»
	Contained in 07VRS:	«-»	«-»	«-»	«-»
	Contained in 08VRS:	«-»	«-»	«-»	«-»
	Supported by supply unit:	«H MV»			

There isn't any diagnostic message existing for the activated operating mode.



On the display of Rexroth IndraDrive supply units, the text "VM" ("Versorgungs-Modul" = supply module) precedes the diagnostic message.

A0800 - Attributes Display:
 Ident N°: A0800

Diagnostic Status Messages

7.79 A4000 Automatic drive check and adjustment

Allocation	Contained in 02VRS:	«MPB»	«MPH»	«MPD»	
	Contained in 03VRS:	«MPB»	«MPH»	«MPD»	
	Contained in 04VRS:	«MPB»	«MPH»	«MPD»	
	Contained in 05VRS:	«MPB»	«MPH»	«MPD»	
	Contained in 06VRS:	«MPB»	«MPH»	«MPD»	«MPC»
	Contained in 07VRS:	«MPB»	«MPH»	«MPD»	«MPC»
	Contained in 08VRS:	«MPB»	«MPH»	«MPD»	«MPC»
	Supported by supply unit:	«-»			

The A4000 diagnostic message is a collective diagnostic message for different system states. It is used for drive check and adjustment. When enabling and disabling the drive enable this diagnosis is automatically activated. The following system states that are processed independent of the parameterization are counted among the drive checks and adjustments:

- the holding brake delay times ("S-0-0206, Drive on delay time", "S-0-0207, Drive off delay time")
- build-up of the air-gap field (in the case of asynchronous motors)
- automatic determination of the commutation offset (in the case of synchronous motors with incremental measuring system)

Depending on the parameterization the automatic brake check is displayed with the A4000 diagnostic message, too (see "P-0-0525, Holding brake control word").

A4000 - Attributes	Display:	AC
	Ident N°:	A4000

7.80 A4001 Drive deceleration to standstill

Allocation	Contained in 02VRS:	«MPB»	«MPH»	«MPD»	
	Contained in 03VRS:	«MPB»	«MPH»	«MPD»	
	Contained in 04VRS:	«MPB»	«MPH»	«MPD»	
	Contained in 05VRS:	«MPB»	«MPH»	«MPD»	
	Contained in 06VRS:	«MPB»	«MPH»	«MPD»	«MPC»
	Contained in 07VRS:	«MPB»	«MPH»	«MPD»	«MPC»
	Contained in 08VRS:	«MPB»	«MPH»	«MPD»	«MPC»
	Supported by supply unit:	«-»			

The drive

- is decelerated to standstill as set in the "P-0-0119, Best possible deceleration" parameter
- or -
- conducts a speed command value reset.



This status is displayed on the control panel of the drive with "AE".

See also Functional Description of firmware "Error"

A4001 - Attributes	Display:	AE
	Ident N°:	A4001

7.81 A4002 Drive in automatic mode

Allocation	Contained in 02VRS:	«-»	«MPH»	«-»	
	Contained in 03VRS:	«MPB»	«MPH»	«-»	
	Contained in 04VRS:	«MPB»	«MPH»	«-»	
	Contained in 05VRS:	«MPB»	«MPH»	«-»	
	Contained in 06VRS:	«MPB»	«MPH»	«-»	«MPC»
	Contained in 07VRS:	«MPB»	«MPH»	«-»	«MPC»
	Contained in 08VRS:	«MPB»	«MPH»	«-»	«MPC»
Supported by supply unit:	«-»				

The drive-integrated PLC (MLD) has permanent (or temporary) control over the drive; this means that the drive is controlled by the drive-integrated PLC.

See also Application Manual "Rexroth IndraMotion MLD"

A4002 - Attributes
 Display: AU
 Ident N°: A4002

7.82 A4003 Setting-up mode is active

Allocation	Contained in 02VRS:	«-»	«-»	«-»	
	Contained in 03VRS:	«-»	«-»	«-»	
	Contained in 04VRS:	«-»	«-»	«-»	
	Contained in 05VRS:	«MPB»	«MPH»	«MPD»	
	Contained in 06VRS:	«MPB»	«MPH»	«MPD»	«MPC»
	Contained in 07VRS:	«MPB»	«MPH»	«MPD»	«MPC»
	Contained in 08VRS:	«MPB»	«MPH»	«MPD»	«MPC»
Supported by supply unit:	«-»				

The "easy startup" mode is provided for controlling the drive manually.



When the "easy startup" mode has been activated, the display switches between the drive address and the message "CM" (Commissioning Mode).

In the "easy startup" mode, all motion commands of the PLC that is integrated in the drive (IndraMotion MLD) or the master communication are ignored.

The drive is in velocity control mode; command values are specified via "P-0-1460, PLC/setting-up mode, velocity command value".

A4003 - Attributes
 Display: AF
 Ident N°: A4003

8 Error Messages

8.1 Fatal System Errors (F9xxx and E-0000)

8.1.1 Behavior in the Case of Fatal System Errors

In the case of fatal system errors, there is a grave problem in the drive system (e.g. watchdog error, processor crash, ...) which does no longer allow regular operation of the drive. Due to a hardware or firmware error, the drive firmware is no longer operable; clearing an error is no longer possible.

In this case the drive reacts automatically as follows:

- Drive Behavior**
- All digital outputs are set to "0".
Safety technology: Safe feedback is deactivated!
 - The "ready for operation" relay opens, this also switches power off in case the wiring is correct.
 - The output stage is locked, this disables the drive torque.
 - The brake output is deactivated; if a self-holding brake is used, it is applied!
 - One of the following diagnostic messages is output at the display:
 - F9xxx (fatal system errors)
 - E8xxx (exceptions)
 - or E-xxxx (processor error), e.g. E-0800 (detailed information in the English language is output via the serial interface)

Putting the Drive Into Operation After a fatal system error has occurred, the drive can only be put into operation again when:

1. The 24V supply is completely switched off and on so that a restart of the drive is carried out (incl. booting process and initialization).
2. The drive is run up to the operating mode again.
3. Power is switched on again.



In case fatal system errors are occurring repeatedly, contact our service department as operating the drive then is no longer possible.

8.1.2 E0000 E-0000 Processor exception error

Allocation	Contained in 02VRS:	«MPB»	«MPH»	«MPD»	
	Contained in 03VRS:	«MPB»	«MPH»	«MPD»	
	Contained in 04VRS:	«MPB»	«MPH»	«MPD»	
	Contained in 05VRS:	«MPB»	«MPH»	«MPD»	
	Contained in 06VRS:	«MPB»	«MPH»	«MPD»	«MPC»
	Contained in 07VRS:	«MPB»	«MPH»	«MPD»	«MPC»
	Contained in 08VRS:	«MPB»	«MPH»	«MPD»	«MPC»
	Supported by supply unit:	«-»			

Cause:

A fatal processor error (processor exception) occurred. The drive was switched off by the firmware (torque-free).

"0000" is a wild card for hexadecimal error codes by means of which the Rexroth service department can recognize the exact cause of the occurrence of the error.

Example "E-0220" means that an unauthorized (incorrect) interrupt call occurred.

Error Messages

E-0000	E-0220	E-0460	E-06C0
E-0020	E-0240	E-0480	E-0700
E-0040	E-0260	E-04A0	E-0720
E-0060	E-0280	E-04C0	E-0740
E-0080	E-02A0	E-04E0	E-0760
E-00A0	E-02C0	E-0500	E-0800
E-00C0	E-02E0	E-0520	E-0820
E-00E0	E-0300	E-0540	E-0A00
E-0100	E-0320	E-0560	E-0A20
E-0120	E-0340	E-0580	E-0A40
E-0140	E-0360	E-05A0	E-0A60
E-0160	E-0380	E-0600	E-0A80
E-0180	E-03A0	E-0620	E-0AA0
E-01A0	E-03C0	E-0640	E-0AC0
E-01C0	E-0400	E-0660	E-0AE0
E-01E0	E-0420	E-0680	E-0B00
E-0200	E-0440	E-06A0	E-0B80

Fig. 8-1: Hexadecimal Error Codes of a Processor Error

Remedy:

Switch drive off and then on again. If the processor error is still displayed, please contact our service department.

E0000 - Attributes	Display:	E-XXXX
	Ident N°:	E0000

8.1.3 F9001 Error internal function call

Allocation	Contained in 02VRS:	«MPB»	«MPH»	«MPD»	
	Contained in 03VRS:	«MPB»	«MPH»	«MPD»	
	Contained in 04VRS:	«MPB»	«MPH»	«MPD»	
	Contained in 05VRS:	«MPB»	«MPH»	«MPD»	
	Contained in 06VRS:	«MPB»	«MPH»	«MPD»	«MPC»
	Contained in 07VRS:	«MPB»	«MPH»	«MPD»	«MPC»
	Contained in 08VRS:	«MPB»	«MPH»	«MPD»	«MPC»
	Supported by supply unit:	«HMV»			

The device was switched off by the firmware.

Cause	Remedy
Undefined cause	Switch device off/on. If error persists, replace device
An error occurred in firmware (general software error)	Please contact our service department

F9001 - Attributes	Display:	F9001
	Ident N°:	F9001

8.1.4 F9002 Error internal RTOS function call

Allocation	Contained in 02VRS:	«MPB»	«MPH»	«MPD»	
	Contained in 03VRS:	«MPB»	«MPH»	«MPD»	
	Contained in 04VRS:	«MPB»	«MPH»	«MPD»	
	Contained in 05VRS:	«MPB»	«MPH»	«MPD»	
	Contained in 06VRS:	«MPB»	«MPH»	«MPD»	«MPC»
	Contained in 07VRS:	«MPB»	«MPH»	«MPD»	«MPC»
	Contained in 08VRS:	«MPB»	«MPH»	«MPD»	«MPC»
	Supported by supply unit:	«-»			

Cause	Remedy
An error occurred in the firmware (general software error). The drive was switched off by the firmware.	Please contact our service department.

F9002 - Attributes **Display:** F9002
 Ident N°: F9002

8.1.5 F9003 Watchdog

Allocation	Contained in 02VRS:	«MPB»	«MPH»	«MPD»	
	Contained in 03VRS:	«MPB»	«MPH»	«MPD»	
	Contained in 04VRS:	«MPB»	«MPH»	«MPD»	
	Contained in 05VRS:	«MPB»	«MPH»	«MPD»	
	Contained in 06VRS:	«MPB»	«MPH»	«MPD»	«MPC»
	Contained in 07VRS:	«MPB»	«MPH»	«MPD»	«MPC»
	Contained in 08VRS:	«MPB»	«MPH»	«MPD»	«MPC»
	Supported by supply unit:	«HMV»			

Cause	Remedy
Firmware-side watchdog timer was triggered (general firmware error). Drive was switched off by firmware.	Replace device, contact our service department

F9003 - Attributes **Display:** F9003
 Ident N°: F9003

8.1.6 F9004 Hardware trap

Allocation	Contained in 02VRS:	«-»	«-»	«-»	
	Contained in 03VRS:	«-»	«-»	«-»	
	Contained in 04VRS:	«-»	«-»	«-»	
	Contained in 05VRS:	«-»	«-»	«-»	
	Contained in 06VRS:	«-»	«-»	«-»	«-»
	Contained in 07VRS:	«-»	«-»	«-»	«-»
	Contained in 08VRS:	«-»	«-»	«-»	«-»
	Supported by supply unit:	«HMV»			

An internal firmware error has occurred. The device was switched off by the firmware.

Cause	Remedy
An error occurred in firmware	Please contact our service department





F9004 - Attributes **Display:** F9004
 Ident N°: F9004

8.2 Fatal Errors (F8xxx)

8.2.1 Behavior in Case of Fatal Errors (F8xxx)

Generally, there are 2 types of fatal errors (F8 errors):

Error Messages

Fatal Errors During Initialization (Initialization Errors)	<ul style="list-style-type: none"> • Fatal errors during initialization (e.g. F8118, F8120,...) • Fatal errors during operation (e.g. F8060, F8022,...) <p>Fatal initialization errors cannot be cleared, they require that the drive be restarted.</p> <hr/> <p> Fatal errors in conjunction with safety technology do not only require that the drive be restarted, but additionally require that the safety technology be completely recommissioned.</p> <hr/> <p> The drive can be restarted by removing the 24 V supply or (as of MPx08) by starting the "Reboot command" (C6400).</p> <hr/>
Fatal Errors During Operation	<p>When a fatal error occurs during operation, control (or U/f control) of the drive is no longer ensured; therefore, drive enable is immediately removed in case of these errors and the holding brake - if available - is switched on. Depending on the setting in "P-0-0119, Best possible deceleration", bit 8, D.C. braking can be additionally activated.</p> <hr/> <p> With the corresponding setting in "P-0-0118, Power supply, configuration", the power supply is disconnected in case of fatal errors.</p> <hr/> <p>See also Application Manual "Error Reactions"</p>
Commissioning Steps	<p>After a fatal error has occurred, the drive can only be put into operation again after the following steps were carried out:</p> <ol style="list-style-type: none"> 1. The error message must be cleared by the error clearing command (cf. "S-0-0099, C0500 Reset class 1 diagnostics") (for this purpose, it might possibly be necessary to switch to parameter mode or to switch the drive off completely). 2. The cause of the error must be recognized and removed; this possibly means that an entire component (e.g. motor or drive controller) must be replaced. 3. The drive must be in operating mode again and power must be switched on again ("Ab"). 4. Drive enable must be switched on again (0-1 edge). <hr/> <p> In case fatal errors are occurring repeatedly, contact our service department as operating the drive then is no longer possible.</p> <hr/>

8.2.2 F8000 Fatal hardware error

Allocation	<table border="0"> <tr> <td>Contained in 02VRS:</td> <td>«-»</td> <td>«-»</td> <td>«-»</td> </tr> <tr> <td>Contained in 03VRS:</td> <td>«MPB»</td> <td>«MPH»</td> <td>«MPD»</td> </tr> <tr> <td>Contained in 04VRS:</td> <td>«MPB»</td> <td>«MPH»</td> <td>«MPD»</td> </tr> <tr> <td>Contained in 05VRS:</td> <td>«MPB»</td> <td>«MPH»</td> <td>«MPD»</td> </tr> <tr> <td>Contained in 06VRS:</td> <td>«MPB»</td> <td>«MPH»</td> <td>«MPD»</td> <td>«MPC»</td> </tr> <tr> <td>Contained in 07VRS:</td> <td>«MPB»</td> <td>«MPH»</td> <td>«MPD»</td> <td>«MPC»</td> </tr> <tr> <td>Contained in 08VRS:</td> <td>«MPB»</td> <td>«MPH»</td> <td>«MPD»</td> <td>«MPC»</td> </tr> <tr> <td>Supported by supply unit:</td> <td>«-»</td> <td></td> <td></td> <td></td> </tr> </table>	Contained in 02VRS:	«-»	«-»	«-»	Contained in 03VRS:	«MPB»	«MPH»	«MPD»	Contained in 04VRS:	«MPB»	«MPH»	«MPD»	Contained in 05VRS:	«MPB»	«MPH»	«MPD»	Contained in 06VRS:	«MPB»	«MPH»	«MPD»	«MPC»	Contained in 07VRS:	«MPB»	«MPH»	«MPD»	«MPC»	Contained in 08VRS:	«MPB»	«MPH»	«MPD»	«MPC»	Supported by supply unit:	«-»			
Contained in 02VRS:	«-»	«-»	«-»																																		
Contained in 03VRS:	«MPB»	«MPH»	«MPD»																																		
Contained in 04VRS:	«MPB»	«MPH»	«MPD»																																		
Contained in 05VRS:	«MPB»	«MPH»	«MPD»																																		
Contained in 06VRS:	«MPB»	«MPH»	«MPD»	«MPC»																																	
Contained in 07VRS:	«MPB»	«MPH»	«MPD»	«MPC»																																	
Contained in 08VRS:	«MPB»	«MPH»	«MPD»	«MPC»																																	
Supported by supply unit:	«-»																																				

Cause "F8000" is a collective diagnostic message for the following fatal hardware errors:

- "F8060 Overcurrent in power section" and
- "F8069 +/-15-volt DC error"

Error Messages

Normally, "F8000" is not visible on the display of the drive controller because "F8060 Overcurrent in power section" or "F8069 +/-15-volt DC error" will be displayed shortly afterwards.

Reading the Exact Cause of an Error at an External Control Unit An external control unit cannot recognize the exact cause of the error; the exact cause of the error, however, can be detected via the service channel by re-reading "S-0-0390, Diagnostic message number" and "S-0-0095, Diagnostic message".

Remedy The particular cause of the error can be found in the diagnostic message which follows error F8000 ("F8060 Overcurrent in power section" or "F8069 +/-15-volt error").

Error Reaction The error reaction defined for fatal errors (F8xxx) is executed on the spot.

F8000 - Attributes **Display:** F8000
Ident N°: F8000

8.2.3 F8010 Autom. commutation: Max. motion range when moving back

Allocation	Contained in 02VRS:	«MPB»	«MPH»	«MPD»	
	Contained in 03VRS:	«MPB»	«MPH»	«MPD»	
	Contained in 04VRS:	«MPB»	«MPH»	«MPD»	
	Contained in 05VRS:	«MPB»	«MPH»	«MPD»	
	Contained in 06VRS:	«MPB»	«MPH»	«MPD»	«MPC»
	Contained in 07VRS:	«MPB»	«MPH»	«MPD»	«MPC»
	Contained in 08VRS:	«MPB»	«MPH»	«MPD»	«MPC»
	Supported by supply unit:	«-»			

The axis moved away from its initial position during the commutation setting process.

With the **saturation method**, this error is generated when the maximum motion range was exceeded and "moving back to start position" had been set.

With the **sine-wave method**, this error is generated independent of the setting "moving back to start position".

Cause	Remedy
Positive feedback of motor; commutation offset determination generated incorrect value for "P-0-0521, Effective commutation offset".	Check motor encoder signals. To do this, move motor knowing manufacturer-side setting for sense of rotation or velocity polarity and check actual position values with regard to polarity and validation. If necessary, invert polarity of motor encoder or invert two motor phases. Carry out commutation setting again.
Positive feedback of motor after motor replacement (servicing) due to connection error.	Check whether direction of motion (sense of rotation) of motor complies with that of motor encoder. If not, invert direction of motion of motor (invert phases) or of motor encoder.

Error Messages

Cause	Remedy
During commutation setting process, axis got into resonance.	Set "search direction for sine-wave method" to "increase of amplitude with priority" in "P-0-0522, Control word for commutation setting" - or - Reduce value in "P-0-0507, Test frequency for angle acquisition" in order modify excitation frequency for sine-wave method compared to resonance frequency of axis.
Due to low friction of mechanical system, axis moved away from its initial position at start of commutation offset setting.	With saturation method, switch off "moving back to start position", if possible on axis-side! With sine-wave method, determine new start values for P-0-0506 and P-0-0507! To do this, set P-0-0506 to "0" and start command C1200!

F8010 - Attributes Display: F8010
 Ident N°: F8010

8.2.4 F8011 Commutation offset could not be determined

Allocation	Contained in 02VRS:	«MPB»	«MPH»	«MPD»	
	Contained in 03VRS:	«MPB»	«MPH»	«MPD»	
	Contained in 04VRS:	«MPB»	«MPH»	«MPD»	
	Contained in 05VRS:	«MPB»	«MPH»	«MPD»	
	Contained in 06VRS:	«MPB»	«MPH»	«MPD»	«MPC»
	Contained in 07VRS:	«MPB»	«MPH»	«MPD»	«MPC»
	Contained in 08VRS:	«MPB»	«MPH»	«MPD»	«MPC»
	Supported by supply unit:	«-»			

The sine-wave method for commutation setting could not determine any value for the commutation offset.

Cause	Remedy
Axis could not carry out required motion	Check axis for stiffness or blocking; if necessary, reduce friction (lubrication, guiding device of trailing cable installation) or remove blocking - or - Set "search direction for sine-wave method" to "increase of amplitude with priority" in "P-0-0522, Control word for commutation setting" - or - Increase value in "P-0-0506, Amplitude for angle acquisition" in order to increase excitation amplitude for sine-wave method compared to frictional force of axis.
During commutation setting process, axis got into resonance	Set "search direction for sine-wave method" to "increase of frequency with priority" in "P-0-0522, Control word for commutation setting" - or - Reduce value in "P-0-0507, Test frequency for angle acquisition" in order modify excitation frequency for sine-wave method compared to resonance frequency of axis
Motor has not been supplied with current	Check motor connection

Cause	Remedy
Sine-wave method without success, although axis has required freedom of motion and doesn't show any resonance phenomena	Try with manually input values if automatic search for motor-specific values for "P-0-0506, Amplitude for angle acquisition" and "P-0-0507, Test frequency for angle acquisition" doesn't provide any result in spite of several repetitions.
Signals of motor encoder do not reflect motion process of axis; encoder cables of 2 drives possibly mixed up - or - Incorrect polarity of encoder signals	Check motor encoder signals. To do this move motor knowing manufacturer-side setting for sense of rotation or velocity polarity and check actual position values with regard to polarity and validation.

F8011 - Attributes **Display:** F8011
 Ident N°: F8011

8.2.5 F8012 Autom. commutation: Max. motion range

Allocation	Contained in 02VRS:	«MPB»	«MPH»	«MPD»	
	Contained in 03VRS:	«MPB»	«MPH»	«MPD»	
	Contained in 04VRS:	«MPB»	«MPH»	«MPD»	
	Contained in 05VRS:	«MPB»	«MPH»	«MPD»	
	Contained in 06VRS:	«MPB»	«MPH»	«MPD»	«MPC»
	Contained in 07VRS:	«MPB»	«MPH»	«MPD»	«MPC»
	Contained in 08VRS:	«MPB»	«MPH»	«MPD»	«MPC»
	Supported by supply unit:	«-»			

During commutation setting (sine-wave method) the axis left the allowed actual position value range.

Cause	Remedy
Heavy axis motion due to too high drive torque or force generation during commutation setting	Reduce value contained in "P-0-0506, Amplitude for angle acquisition" - and / or - Increase value contained in "P-0-0507, Test frequency for angle acquisition"
External forces or torques cause axis to move out of allowed actual position value range	Check mechanical axis system for occurrence of external forces, e.g. due to trailing cable installation, vertical load etc.
Cogging force or torque causes axis to move out of allowed actual position value range	Make sure that, during commutation setting by means of sine-wave method, cogging forces of motor do not cause position limits to be exceeded near limits of actual position value range

F8012 - Attributes **Display:** F8012
 Ident N°: F8012

8.2.6 F8013 Automatic commutation: Current too low

Allocation	Contained in 02VRS:	«MPB»	«MPH»	«MPD»	
	Contained in 03VRS:	«MPB»	«MPH»	«MPD»	
	Contained in 04VRS:	«MPB»	«MPH»	«MPD»	
	Contained in 05VRS:	«MPB»	«MPH»	«MPD»	
	Contained in 06VRS:	«MPB»	«MPH»	«MPD»	«MPC»
	Contained in 07VRS:	«MPB»	«MPH»	«MPD»	«MPC»
	Contained in 08VRS:	«MPB»	«MPH»	«MPD»	«MPC»
	Supported by supply unit:	«-»			

The actual current value amplitude resulting from commutation setting with the saturation method is monitored. When it does not exceed a minimum threshold, the error F8013 is generated.

Error Messages

Cause	Remedy
Actual current value amplitude is not sufficient for exact determination of commutation offset	<p>Increase signal voltage ("P-0-0506, Amplitude for angle acquisition" or reduce signal frequency ("P-0-0507, Test frequency for angle acquisition" and restart commutation setting process.</p> <p>- or -</p> <p>Enter value "0" in "P-0-0506, Amplitude for angle acquisition" Appropriate value for P-0-0506 is thereby automatically determined during commutation setting process.</p> <p>- or -</p> <p>Reduce value of "P-0-0517, Commutation: required harmonics component", if approx. 30 similar values are determined for "P-0-0521, Effective commutation offset" with repeated commutation setting for different motor positions (drive remains in "Ab"). Reduce "P-0-0517, Commutation: required harmonics component" until command error F8013 no longer occurs; finally check function several times!</p>



If error occurs repeatedly, please contact our service department.

F8013 - Attributes

Display: F8013
Ident N°: F8013

8.2.7 F8014 Automatic commutation: Overcurrent

Allocation	Contained in 02VRS:	«MPB»	«MPH»	«MPD»	
	Contained in 03VRS:	«MPB»	«MPH»	«MPD»	
	Contained in 04VRS:	«MPB»	«MPH»	«MPD»	
	Contained in 05VRS:	«MPB»	«MPH»	«MPD»	
	Contained in 06VRS:	«MPB»	«MPH»	«MPD»	«MPC»
	Contained in 07VRS:	«MPB»	«MPH»	«MPD»	«MPC»
	Contained in 08VRS:	«MPB»	«MPH»	«MPD»	«MPC»
	Supported by supply unit:	«-»			

The actual current value amplitude resulting from automatic commutation offset determination is monitored. When a maximum value is exceeded, the error F8014 is generated.

Cause	Remedy
Amplitude of actual current value is higher than allowed maximum current	<p>Reduce signal voltage ("P-0-0506, Voltage amplitude for angle acquisition") or increase signal frequency ("P-0-0507, Test frequency for angle acquisition").</p> <p>- or -</p> <p>With "P-0-0506, Voltage amplitude for angle acquisition"=0 start automatic determination of appropriate values.</p>



If error occurs repeatedly, please contact our service department.

F8014 - Attributes

Display: F8014
Ident N°: F8014

8.2.8 F8015 Automatic commutation: Timeout

Allocation	Contained in 02VRS:	«MPB»	«MPH»	«MPD»	
	Contained in 03VRS:	«MPB»	«MPH»	«MPD»	
	Contained in 04VRS:	«MPB»	«MPH»	«MPD»	
	Contained in 05VRS:	«MPB»	«MPH»	«MPD»	
	Contained in 06VRS:	«MPB»	«MPH»	«MPD»	«MPC»
	Contained in 07VRS:	«MPB»	«MPH»	«MPD»	«MPC»
	Contained in 08VRS:	«MPB»	«MPH»	«MPD»	«MPC»
	Supported by supply unit:	«-»			

Saturation Method During the execution of the automatic commutation offset determination (after drive enable) an error was detected.

Cause	Remedy
An error occurred in internal signal generator used for determining commutation offset.	Switch drive off and on again. If error continues to be signaled, contact our service department.

Sine-Wave Method The commutation setting with motion by means of the sine-wave method is completed when the axis, after commutation offset determination, has been moved back to the initial position at which it was before the start. If this is impossible, the error F8015 is generated.

Cause	Remedy
Axis cannot be moved back to position at which it was at beginning of commutation determination.	Check mechanical axis system, remove blocking or stiffness.

F8015 - Attributes **Display:** F8015
 Ident N°: F8015

8.2.9 F8016 Automatic commutation: Iteration without result

Allocation	Contained in 02VRS:	«MPB»	«MPH»	«MPD»	
	Contained in 03VRS:	«MPB»	«MPH»	«MPD»	
	Contained in 04VRS:	«MPB»	«MPH»	«MPD»	
	Contained in 05VRS:	«MPB»	«MPH»	«MPD»	
	Contained in 06VRS:	«MPB»	«MPH»	«MPD»	«MPC»
	Contained in 07VRS:	«MPB»	«MPH»	«MPD»	«MPC»
	Contained in 08VRS:	«MPB»	«MPH»	«MPD»	«MPC»
	Supported by supply unit:	«-»			

During the automatic commutation offset determination (after drive enable) it has been impossible to find appropriate values for "P-0-0506, Voltage amplitude for angle acquisition" and "P-0-0507, Test frequency for angle acquisition" with which it would be possible to determine a useful commutation offset of the connected motor.

Error Messages

Cause	Remedy
Current generated during automatic commutation offset determination could not produce any saturation effect in motor. Required maximum current is approx. 1.5-fold continuous current at standstill ("S-0-0111, Motor current at standstill").	Check whether controller can supply motor with sufficiently high current (cf. "S-0-0111, Motor current at standstill" and "S-0-0110, Amplifier peak current"). If maximum controller current is too low, drive controller has to be replaced by a bigger one. - or - Change position of movable part of motor with regard to its rigid part restart command "P-0-0524, C1200 Commutation offset setting command". - or - Contact our service department and, if necessary, use an absolute measuring system, because motor characteristics do not allow automatic commutation.

See also Functional Description of firmware "Commutation Setting"

F8016 - Attributes Display: F8016
 Ident N°: F8016

8.2.10 F8017 Automatic commutation: Incorrect commutation adjustment

Allocation	Contained in 02VRS:	«-»	«-»	«-»	
	Contained in 03VRS:	«-»	«-»	«-»	
	Contained in 04VRS:	«-»	«-»	«-»	
	Contained in 05VRS:	«MPB»	«MPH»	«MPD»	
	Contained in 06VRS:	«MPB»	«MPH»	«MPD»	«MPC»
	Contained in 07VRS:	«MPB»	«MPH»	«MPD»	«MPC»
	Contained in 08VRS:	«MPB»	«MPH»	«MPD»	«MPC»
	Supported by supply unit:	«-»			



This error only occurs during sensorless positioning of synchronous motors.

An error occurred during commutation adjust of the carrier-signal-based rotor position detection. It was impossible to determine the alignment of the rotor.

Cause	Remedy
It was impossible to determine initial position of rotor.	Check whether parameter values of sensorless positioning of synchronous motors correspond to specification.
Rotor was moving during transient oscillation of rotor position estimation.	Make sure that rotor does not turn during commutation process.

Error Messages

Cause	Remedy
An error occurred when rotor angles determined before and after commutation adjust were compared.	Make sure that rotor does not turn during commutation process. - and/or - Adjust parameter values of "P-0-0506, Amplitude for angle acquisition", "P-0-0507, Test frequency for angle acquisition" and "P-0-0517, Commutation: required harmonics component" or start search mode. - and/or - Check whether parameter values of sensorless positioning of synchronous motors correspond to specification.
Determined commutation offset is wrong. - and/or - Rotor was moving during saturation method.	Adjust parameter values of "P-0-0506, Amplitude for angle acquisition", "P-0-0507, Test frequency for angle acquisition" and "P-0-0517, Commutation: required harmonics component" or start search mode.



If error occurs repeatedly, please contact our service department.

F8017 - Attributes Display: F8017
 Ident N°: F8017

8.2.11 F8018 Device overtemperature shutdown

Allocation	Contained in 02VRS:	«-»	«-»	«-»	
	Contained in 03VRS:	«-»	«-»	«-»	
	Contained in 04VRS:	«-»	«-»	«-»	
	Contained in 05VRS:	«MPB»	«MPH»	«MPD»	
	Contained in 06VRS:	«MPB»	«MPH»	«MPD»	«MPC»
	Contained in 07VRS:	«MPB»	«MPH»	«MPD»	«MPC»
	Contained in 08VRS:	«MPB»	«MPH»	«MPD»	«MPC»
	Supported by supply unit:	«-»			

The heat sink temperature of the device is monitored by a temperature sensor and a temperature model. When the heat sink temperature exceeds the maximum value set for the device and when the load determined by the temperature model has reached the absolute limit value set for the device, the device goes torque-free in order to protect it against destruction.



The error can only be cleared when the device has cooled down.

Cause	Remedy
Overtemperature (heat sink) due to overload of device	Switch drive off and let it cool down. Check mechanical system and drive sizing (on average, working power may not exceed continuous power of drive) For liquid-cooled devices: Check dimensioning of cooling system (see documentation with part number R911309636)
Ambient temperature too high. Specified performance data is valid up to an ambient temperature of 40 °C	Reduce ambient temperature, e.g. by cooling the control cabinet
Heat sink of device is dirty	Clean heat sink
Convection is prevented by other components or mounting position in control cabinet	Mount device vertically and provide sufficient space for ventilating heat sink

Error Messages

Cause	Remedy
Device-internal blower failed	If blower fails, replace device or power section
Failure of air conditioning for control cabinet	Check air conditioning of control cabinet
Incorrect dimensioning of control cabinet with regard to heat dissipation	Check dimensioning of control cabinet
For liquid-cooled devices: No cooling system connected	Connect cooling system
For liquid-cooled devices: Error in cooling system, e.g. coolant pump defective or filter clogged; thereby flow rate too small / inlet temperature of coolant too high	Check cooling system and remove error

See also Functional Description of firmware "Current Limitation Loop".

F8018 - Attributes Display: F8018
 Ident N°: F8018

8.2.12 F8022 Enc. 1: Enc. signals incorr. (can be cleared in ph. 2)

Allocation	Contained in 02VRS:	«MPB»	«MPH»	«MPD»	
	Contained in 03VRS:	«MPB»	«MPH»	«MPD»	
	Contained in 04VRS:	«MPB»	«MPH»	«MPD»	
	Contained in 05VRS:	«MPB»	«MPH»	«MPD»	
	Contained in 06VRS:	«MPB»	«MPH»	«MPD»	«MPC»
	Contained in 07VRS:	«MPB»	«MPH»	«MPD»	«MPC»
	Contained in 08VRS:	«MPB»	«MPH»	«MPD»	«MPC»
	Supported by supply unit:	«-»			

The signals of the measuring system (encoder 1) are monitored with regard to their amplitudes and signal shape. If a signal (e.g. sin or cos) leaves the thresholds monitored by the hardware or if the signals are disturbed in such a way that a position error occurs, the error F8022 is generated.



As the position of the measuring system is no longer generated correctly when the error F8022 is detected, it is necessary to initialize the encoder again.

The error can only be cleared in communication phase 2 (parameter mode).

Cause	Remedy
Defective encoder cable or cable shielding.	Check cable to measuring system and replace it, if necessary.
Measuring system defective.	Check measuring system and replace it, if necessary
Faulty mounting of measuring head in the case of linear measuring systems.	Check mounting of measuring head and correct it, if necessary.
Measuring system dirty	Clean or replace measuring system
Hardware defect on control section of drive.	Replace control section or entire drive controller.



Only Rexroth service engineers or especially trained users are allowed to replace the control section. The replacement of the entire drive controller is described in the Project Planning Manual for the power section.

See also "E2074 Encoder 1: encoder signals disturbed".

F8022 - Attributes **Display:** F8022
 Ident N°: F8022

8.2.13 F8023 Error mechanical link of encoder or motor connection

Allocation	Contained in 02VRS:	«MPB»	«MPH»	«MPD»	
	Contained in 03VRS:	«MPB»	«MPH»	«MPD»	
	Contained in 04VRS:	«MPB»	«MPH»	«MPD»	
	Contained in 05VRS:	«MPB»	«MPH»	«MPD»	
	Contained in 06VRS:	«MPB»	«MPH»	«MPD»	«MPC»
	Contained in 07VRS:	«MPB»	«MPH»	«MPD»	«MPC»
	Contained in 08VRS:	«MPB»	«MPH»	«MPD»	«MPC»
	Supported by supply unit:	«-»			

The controller monitors the motor using model calculation and other means. The input variables required for model calculation are checked for validity. Unless the check is passed, this error message is generated.

Cause	Remedy
Mechanical connection between motor rotor and motor encoder loose or broken	Check and restore or repair connection
Phase failure in motor supply line	<ul style="list-style-type: none"> • Check motor supply line for continuity. Take potential "loose contacts" into account. • Check connection of motor supply line to controller. • Check connection of motor supply line to motor. • Line break in motor. Replace motor. • Line break in controller. Replace controller.
Monitoring signal for encoder validity (P-0-0620) not within limits of P-0-0621 and P-0-0622 (upper and lower monitoring thresholds of encoder validity monitoring) because of incorrectly set commutation offset	Re-determine commutation offset (see Functional Description of firmware "Commutation Setting")
Monitoring signal for encoder validity (P-0-0620) not within limits of P-0-0621 and P-0-0622 (upper and lower monitoring thresholds of encoder validity monitoring) despite correctly set commutation offset	Using P-0-0520, parameterize encoder validity monitoring limits such that monitoring range in working point of motor is not left (initiate oscilloscope measurement if necessary)
Synchronous motor: Commutation offset is inaccurate	Re-determine commutation offset or start fine adjustment
Motor parameters are inaccurate	Check motor parameters; increase "P-0-0520, Encoder validation error threshold factor" if necessary

F8023 - Attributes **Display:** F8023
 Ident N°: F8023

8.2.14 F8025 Overvoltage in power section

Allocation	Contained in 02VRS:	«-»	«-»	«-»	
	Contained in 03VRS:	«-»	«-»	«-»	
	Contained in 04VRS:	«-»	«-»	«-»	
	Contained in 05VRS:	«MPB»	«MPH»	«MPD»	
	Contained in 06VRS:	«MPB»	«MPH»	«MPD»	«MPC»
	Contained in 07VRS:	«MPB»	«MPH»	«MPD»	«MPC»
	Contained in 08VRS:	«MPB»	«MPH»	«MPD»	«MPC»
	Supported by supply unit:	«-»			

The DC bus voltage is monitored. When the allowed maximum value is exceeded, the error F8025 is triggered in the case of carrier-signal-based determination of the rotor position.

Error Messages

Cause	Remedy
Energy regenerated to DC bus by mechanical machine system during braking process was so high that supply unit couldn't dissipate it during regeneration time. This caused DC bus voltage to rise to inadmissible value.	Reduce regenerative power by lower acceleration values. – or – Correct sizing of drive. – or – Sufficiently dimension supply unit as regards braking energy requirements; if necessary, use additional braking resistor if existing braking resistor has been under-dimensioned.
Mains supply voltage (alternating input voltage) too high.	Check mains supply voltage (alternating voltage/3-phase).
No braking resistor connected or connection or cable defective.	Connect braking resistor or check connection.
F8xxx error at high speed (field weakening range) of a synchronous motor.	Check whether braking resistance value in DC bus exceeds maximum value allowed for motor; if necessary, reduce braking resistance value to or below allowed value.
Incorrect parameterization of sensorless positioning of synchronous motors.	Check whether parameter values of sensorless positioning of synchronous motors correspond to specification.



If the error occurs repeatedly, please contact our service department.

F8025 - Attributes

Display: F8025
Ident N°: F8025

8.2.15 F8027 Safe torque off while drive enabled

Allocation	Contained in 02VRS:	«MPB»	«MPH»	«MPD»	
	Contained in 03VRS:	«MPB»	«MPH»	«MPD»	
	Contained in 04VRS:	«MPB»	«MPH»	«MPD»	
	Contained in 05VRS:	«MPB»	«MPH»	«MPD»	
	Contained in 06VRS:	«MPB»	«MPH»	«MPD»	«MPC»
	Contained in 07VRS:	«MPB»	«MPH»	«MPD»	«MPC»
	Contained in 08VRS:	«MPB»	«MPH»	«MPD»	«MPC»
	Supported by supply unit:	«-»			



Up to MPx06, the name of this diagnostic message was "F8027 Safety related standstill while drive enabled".



When the error occurs, the drive immediately goes torque-free!

Optional Module "Starting
Lockout" (up to MPx06) or "Safe
Torque Off" (as of MPx07)

Cause	Remedy
Up to MPx06: "Starting lockout" was set with active control or drive enable was set with active "starting lockout"	Check control and connection of inputs "AS A", "AS B" and "AS n"
As of MPx07: Safety function "Safe torque off" was set with active control or drive enable was set with active safety function "Safe torque off"	Check control and connection of inputs "STO A", "STO B" and "STO n"

Optional Module "Safety
Technology I/O" (up to MPx06) or
"Safe Motion" (as of MPx07)

Cause	Remedy
<p>Up to MPx06: Drive enable was set while "drive interlock" or "safety related standstill" had been active</p> <p>- or -</p> <p>Drive enable was set while drive was in error status "safety related standstill error" due to internal safety technology error</p>	<p>Do not set drive enable while drive is in one of the described states</p>

F8027 - Attributes Display: F8027
 Ident N°: F8027

8.2.16 F8028 Overcurrent in power section

Allocation	Contained in 02VRS:	«-»	«-»	«-»	
	Contained in 03VRS:	«-»	«-»	«-»	
	Contained in 04VRS:	«-»	«-»	«-»	
	Contained in 05VRS:	«MPB»	«MPH»	«MPD»	
	Contained in 06VRS:	«MPB»	«MPH»	«MPD»	«MPC»
	Contained in 07VRS:	«MPB»	«MPH»	«MPD»	«MPC»
	Contained in 08VRS:	«MPB»	«MPH»	«MPD»	«MPC»
	Supported by supply unit:	«-»			

The controller monitors the motor current (= controller output current) supplied by the power section. When the controller output current is greater than the 1.2-fold value of "S-0-0110, Amplifier peak current", the output stage of the power section is locked.

Cause	Remedy
<p>Incorrect parameterization of sensorless positioning of synchronous motors.</p>	<p>Check whether parameter values of sensorless positioning of synchronous motors correspond to specification.</p>
<p>Rotor position incorrectly determined.</p> <p>Possible causes:</p> <ul style="list-style-type: none"> • Acceleration outside of specification • Maximum speed exceeded • Error in control loop 	<p>Check whether preset limit values are complied with.</p>



If the error occurs repeatedly, please contact our service department.

F8028 - Attributes Display: 8028
 Ident N°: F8028

8.2.17 F8030 Safe stop 1 while drive enabled

Allocation	Contained in 02VRS:	«-»	«-»	«-»	
	Contained in 03VRS:	«-»	«-»	«-»	
	Contained in 04VRS:	«-»	«-»	«-»	
	Contained in 05VRS:	«-»	«-»	«-»	
	Contained in 06VRS:	«-»	«-»	«-»	«-»
	Contained in 07VRS:	«MPB»	«MPH»	«MPD»	«MPC»
	Contained in 08VRS:	«MPB»	«MPH»	«MPD»	«MPC»
	Supported by supply unit:	«-»			



When the error occurs, the drive immediately goes torque-free!

Error Messages

Cause	Remedy
In one of the following safety technology operating states or in internal error status, drive enable was set with safe torque off: <ul style="list-style-type: none"> "Safe stop 1" or "Safe stop 1 (Emergency stop)" or "Safe parking axis" 	Before drive enable, make sure by means of P-0-3213 that drive no longer is in one of the mentioned safety technology operating states or in internal error status

F8030 - Attributes Display: F8030
Ident N°: F8030

8.2.18 F8042 Encoder 2 error: Signal amplitude incorrect

Allocation	Contained in 02VRS:	«-»	«-»	«-»	
	Contained in 03VRS:	«MPB»	«MPH»	«MPD»	
	Contained in 04VRS:	«MPB»	«MPH»	«MPD»	
	Contained in 05VRS:	«MPB»	«MPH»	«MPD»	
	Contained in 06VRS:	«MPB»	«MPH»	«MPD»	«MPC»
	Contained in 07VRS:	«MPB»	«MPH»	«MPD»	«MPC»
	Contained in 08VRS:	«MPB»	«MPH»	«MPD»	«MPC»
	Supported by supply unit:	«-»			

The signals of the measuring system (encoder 2) are monitored on hardware and software level with regard to their amplitudes and signal shape. If a signal (sin or cos) leaves the allowed range or if the signals are disturbed in such a way that a position error occurs, this error is generated. The error only occurs in conjunction with the function "redundant motor encoder"!



As the position is no longer generated correctly when this error is detected, it is necessary to initialize the encoder again.



When using an incremental encoder with square-wave signals, monitoring is carried out with regard to an inadmissible edge.

On the software level, the signals of a resolver are monitored for their levels.

Cause	Remedy
Defective encoder cable or cable shielding	Check cable to measuring system and replace it, if necessary.
Encoder defective	Check measuring system and replace it, if necessary.
Faulty mounting of measuring head in the case of linear measuring systems	Check mounting of measuring head and correct it, if necessary.
Measuring system dirty	Replace measuring system
Hardware defect on control section of drive	Replace control section or entire drive controller.



Only Rexroth service engineers or especially trained users are allowed to replace the control section. The replacement of the entire drive controller is described in the Project Planning Manual for the power section.

F8042 - Attributes Display: F8042
Ident N°: F8042

8.2.19 F8057 Device overload shutdown

Allocation	Contained in 02VRS:	«-»	«-»	«-»
	Contained in 03VRS:	«-»	«-»	«-»
	Contained in 04VRS:	«-»	«-»	«-»
	Contained in 05VRS:	«-»	«-»	«-»
	Contained in 06VRS:	«-»	«-»	«-»
	Contained in 07VRS:	«-»	«-»	«-»
	Contained in 08VRS:	«-»	«-»	«-»
	Supported by supply unit:	«HMV»		

The device was switched off due to overload.

Cause	Remedy
Power demanded by drives is too high	Use drives with lower peak current
Power demanded by drives is too high	Reduce allowed acceleration of axis or reduce final velocity to which acceleration takes place

F8057 - Attributes Display: F8057
 Ident N°:

8.2.20 F8060 Overcurrent in power section

Allocation	Contained in 02VRS:	«MPB»	«MPH»	«MPD»	
	Contained in 03VRS:	«MPB»	«MPH»	«MPD»	
	Contained in 04VRS:	«MPB»	«MPH»	«MPD»	
	Contained in 05VRS:	«MPB»	«MPH»	«MPD»	
	Contained in 06VRS:	«MPB»	«MPH»	«MPD»	«MPC»
	Contained in 07VRS:	«MPB»	«MPH»	«MPD»	«MPC»
	Contained in 08VRS:	«MPB»	«MPH»	«MPD»	«MPC»
	Supported by supply unit:	«-»			

The current in the power transistors has exceeded the maximum allowed device peak current (cf. "S-0-0110, Amplifier peak current").



In the case of an internal signal voltage error (15 V) in the power section, this error message is generated, even without power, directly when the device is switched on, before power is demanded from the power section.

Cause	Remedy
External 24 V supply is not sufficiently overload-proof	Check overload withstand capability of external 24 V power supply unit and replace it, if necessary
Short circuit in motor or motor cable	Check motor cable and motor for short circuit
Power section of drive controller is defective	Replace drive controller
Current loop parameterized differently	Check current loop parameterization (cf. motor data sheet) and correct it if necessary after having contacted our service department
Voltage fluctuations in DC bus too high because system impedance too high	Reduce system impedance, e.g. increase feed wire cross sections

F8060 - Attributes Display: F8060
 Ident N°: F8060

Error Messages

8.2.21 F8064 Interruption of motor phase

Allocation	Contained in 02VRS:	«-»	«-»	«-»	
	Contained in 03VRS:	«-»	«-»	«-»	
	Contained in 04VRS:	«MPB»	«MPH»	«MPD»	
	Contained in 05VRS:	«MPB»	«MPH»	«MPD»	
	Contained in 06VRS:	«MPB»	«MPH»	«MPD»	«MPC»
	Contained in 07VRS:	«MPB»	«MPH»	«MPD»	«MPC»
	Contained in 08VRS:	«MPB»	«MPH»	«MPD»	«MPC»
	Supported by supply unit:	«-»			

During voltage-controlled U/f operation for asynchronous motors, the drive monitors the motor current in the individual line phases.

The drive has detected that the current is "0" in at least one phase.

⚠ DANGER

Lethal injury caused by coasting axis (torque disable)!

⇒ Additional measures might be necessary to stop the axis.

Restrictions of Correct Monitoring Function

- Safe monitoring of individual phases is only possible with a speed command value of >10 U/min.
- The monitoring function also triggers if the motor has been incorrectly parameterized (e.g. the value parameterized for "P-0-4004, Magnetizing current" is much higher than the actually available magnetizing current).

⚠ DANGER

Lethal electric shock by live parts with more than 50 V!

⇒ Observe the safety regulations when working / conducting checks at the drive controller / motor.

Cause	Remedy
At least one line phase of motor has not been connected to drive controller or line break has occurred	Check motor cable connection (check assignment motor connection↔axis). Check individual motor phases from connection at drive controller for line break and high ohmic resistance
For a double-axis device, the two motor power connections were interchanged or generally incorrect axis assignment was made between motor and controller	Check whether assignment of motor connections is correct for the axes
Motor winding (U, V, W) has burned out	Check motor winding by means of ohmmeter and replace motor, if necessary
Voltage boost too low in U/f operation	Adjust P-0-0568 until magnetizing current flows at standstill (P-0-0440 corresponds to P-0-4004)
Motor incorrectly parameterized	Compare motor data in drive to actual motor data (see also Functional Description of firmware "Rexroth Motors" and "Determining the Parameter Values of Third-Party Motors")
Power section defective	Replace drive controller



The sequence of the replacement of drive controllers is described in the documentation "Project Planning Manual for Power Section".

F8064 - Attributes Display: F8064
 Ident N°: F8064

8.2.22 F8067 Synchronization PWM-Timer wrong

Allocation	Contained in 02VRS:	«MPB»	«-»	«-»	
	Contained in 03VRS:	«MPB»	«-»	«-»	
	Contained in 04VRS:	«MPB»	«-»	«-»	
	Contained in 05VRS:	«MPB»	«-»	«-»	
	Contained in 06VRS:	«MPB»	«-»	«-»	«-»
	Contained in 07VRS:	«MPB»	«-»	«-»	«-»
	Contained in 08VRS:	«MPB»	«-»	«-»	«-»
	Supported by supply unit:	«-»			

Digital drive control requires absolutely synchronous data processing (e.g. sampling of actual current values); if this is not guaranteed, controlled operation is impossible and the error F8067 is generated.

Cause	Remedy
Synchronization clock of bus master oscillates very much due to software or hardware error [e.g. jitter of MST with SERCOS (F2067 and F8067)].	Check external bus master and make sure synchronization clock is error-free and constant.
Control section defective	Replace control section or entire drive controller.
Internal timing problem in drive firmware	Contact our service department for firmware update.



Only Rexroth service engineers or especially trained users are allowed to replace the control section. The replacement of the entire drive controller is described in the Project Planning Manual for the power section.

See also Functional Description of firmware " Master Communication".

F8067 - Attributes Display: F8067
 Ident N°: F8067

8.2.23 F8069 +/-15Volt DC error

Allocation	Contained in 02VRS:	«MPB»	«MPH»	«MPD»	
	Contained in 03VRS:	«MPB»	«MPH»	«MPD»	
	Contained in 04VRS:	«MPB»	«MPH»	«MPD»	
	Contained in 05VRS:	«MPB»	«MPH»	«MPD»	
	Contained in 06VRS:	«MPB»	«MPH»	«MPD»	«MPC»
	Contained in 07VRS:	«MPB»	«MPH»	«MPD»	«MPC»
	Contained in 08VRS:	«MPB»	«MPH»	«MPD»	«MPC»
	Supported by supply unit:	«HMV»			

An error has occurred in the internal +/-15 V supply of the device.



The error cannot be cleared via the command "S-0-0099, C0500 Reset class 1 diagnostics".

Cause	Remedy
Error in external DC24 V power supply	Check external power supply
Power section defective	Replace device

F8069 - Attributes Display: F8069
 Ident N°: F8069

Error Messages

8.2.24 F8070 +24Volt DC error

Allocation	Contained in 02VRS:	«MPB»	«MPH»	«MPD»	
	Contained in 03VRS:	«MPB»	«MPH»	«MPD»	
	Contained in 04VRS:	«MPB»	«MPH»	«MPD»	
	Contained in 05VRS:	«MPB»	«MPH»	«MPD»	
	Contained in 06VRS:	«MPB»	«MPH»	«MPD»	«MPC»
	Contained in 07VRS:	«MPB»	«MPH»	«MPD»	«MPC»
	Contained in 08VRS:	«MPB»	«MPH»	«MPD»	«MPC»
	Supported by supply unit:	«HMV»			

Rexroth IndraDrive devices need an external 24 V control voltage supply for operation. This voltage is monitored with regard to the allowed tolerance.



When the error F8070 occurs, the motors within the drive system immediately go torque-free. Apply possibly existing self-holding motor holding brakes.



The error F8070 cannot be cleared by the error clearing command (cf. "S-0-0099, C0500 Reset class 1 diagnostics"). To clear the error, the drive must be switched off completely!

Cause	Remedy
Supply cable for control voltages defective	Check and, if necessary, replace supply cable for control voltages and connector
Overload of 24 V power supply unit	Check 24 V supply voltage at power supply unit
Power supply unit defective	Check and, if necessary, replace power supply unit
Short circuit in 24 V supply wiring	Check 24 V supply wiring for short circuit

F8070 - Attributes Display: F8070
 Ident N°: F8070

8.2.25 F8076 Error in error angle loop

Allocation	Contained in 02VRS:	«-»	«-»	«-»	
	Contained in 03VRS:	«-»	«-»	«-»	
	Contained in 04VRS:	«-»	«-»	«-»	
	Contained in 05VRS:	«MPB»	«MPH»	«MPD»	
	Contained in 06VRS:	«MPB»	«MPH»	«MPD»	«MPC»
	Contained in 07VRS:	«MPB»	«MPH»	«MPD»	«MPC»
	Contained in 08VRS:	«MPB»	«MPH»	«MPD»	«MPC»
	Supported by supply unit:	«-»			



This error only occurs with sensorless positioning of synchronous motors.

An error in the position detection has occurred with sensorless positioning of synchronous motors. For reasons of safety, the output stage is locked.

⚠ DANGER

Lethal injury caused by coasting axis (torque disable)!

⇒ Additional measures might be necessary to stop the axis.

Error Messages

Cause	Remedy
Incorrect parameterization of sensorless positioning of synchronous motors.	Check whether parameter values of sensorless positioning of synchronous motors correspond to specification.
Rotor position incorrectly determined. Possible causes: <ul style="list-style-type: none"> • Acceleration too high • Speed too high • Instability in speed control loop • Power line defective 	Check whether preset limit values are complied with.



If the error occurs repeatedly, please contact our service department.

F8076 - Attributes

Display: F8076
 Ident N°: F8076

8.2.26 F8078 Speed loop error

Allocation	Contained in 02VRS:	«MPB»	«MPH»	«MPD»	
	Contained in 03VRS:	«MPB»	«MPH»	«MPD»	
	Contained in 04VRS:	«MPB»	«MPH»	«MPD»	
	Contained in 05VRS:	«MPB»	«MPH»	«MPD»	
	Contained in 06VRS:	«MPB»	«MPH»	«MPD»	«MPC»
	Contained in 07VRS:	«MPB»	«MPH»	«MPD»	«MPC»
	Contained in 08VRS:	«MPB»	«MPH»	«MPD»	«MPC»
	Supported by supply unit:	«-»			

The velocity loop monitor is activated if the following conditions occur simultaneously:

- "P-0-0049, Effective torque/force command value" is at the torque/force limit.
- "P-0-0049, Effective torque/force command value" and actual velocity have different signs.
- The actual velocity at the **motor shaft** is greater than 20 rpm (or 20 mm/min for linear motors).
- Actual acceleration and control deviation have different signs.

Cause	Remedy
Motor phases (U, V, W) interchanged so that commutation of motor is incorrect	Check motor cable connection and correct phase assignment, if necessary
Incorrect encoder arrangement	Correct encoder arrangement (inverting rotational direction of encoder can possibly resolve problem)
Velocity loop setting incorrect	Check velocity loop setting according to Functional Description/Application Manual
Commutation offset incorrect	Replace motor (in the case of MHD, MKD, MKE motors); in the case of kit motors, make commutation settings
Drive is operated in voltage-controlled form (without encoder; U/f control); with this drive function, velocity loop monitoring does not make sense	Deactivate velocity loop monitoring in P-0-0556
Motor encoder defective	Replace motor encoder (or motor)

Error Messages

F8078 - Attributes Display: F8078
 Ident N°: F8078

8.2.27 F8079 Velocity limit value exceeded

Allocation	Contained in 02VRS:	«MPB»	«MPH»	«MPD»	
	Contained in 03VRS:	«MPB»	«MPH»	«MPD»	
	Contained in 04VRS:	«MPB»	«MPH»	«MPD»	
	Contained in 05VRS:	«MPB»	«MPH»	«MPD»	
	Contained in 06VRS:	«MPB»	«MPH»	«MPD»	«MPC»
	Contained in 07VRS:	«MPB»	«MPH»	«MPD»	«MPC»
	Contained in 08VRS:	«MPB»	«MPH»	«MPD»	«MPC»
	Supported by supply unit:	«-»			

Cause	Remedy
"S-0-0040, Velocity feedback value" has exceeded the 1.125- fold value of one of parameterized velocity limit values	Check and, if necessary, correct parameterization of "S-0-0091, Bipolar velocity limit value", "S-0-0038, Positive velocity limit value" and "S-0-0039, Negative velocity limit value". As of MPx06: Within parameterized standstill window (S-0-0124), actual velocity is not monitored for resulting limits from S-0-0091, S-0-0038 and S-0-0039.
Velocity control loop unstable or too heavily oscillating due to incorrect parameterization	Check and, if necessary, correct parameterization of velocity loop
Preset velocity command value too high (cf. P-0-0048 = "S-0-0036, Velocity command value" + "S-0-0037, Additive velocity command value")	Reduce "P-0-0048, Effective velocity command value" by adjusting "S-0-0036, Velocity command value" or "S-0-0037, Additive velocity command value"

See also Functional Description of firmware "Control Loop Structure"

F8079 - Attributes Display: F8079
 Ident N°: F8079

8.2.28 F8091 Power section defective

Allocation	Contained in 02VRS:	«MPB»	«MPH»	«MPD»	
	Contained in 03VRS:	«MPB»	«MPH»	«MPD»	
	Contained in 04VRS:	«MPB»	«MPH»	«MPD»	
	Contained in 05VRS:	«MPB»	«MPH»	«MPD»	
	Contained in 06VRS:	«MPB»	«MPH»	«MPD»	«MPC»
	Contained in 07VRS:	«MPB»	«MPH»	«MPD»	«MPC»
	Contained in 08VRS:	«MPB»	«MPH»	«MPD»	«MPC»
	Supported by supply unit:	«-»			

During the initialization of the power section, the drive tries to access the power section parameters.

These are the following parameters:

- S-0-0140, Controller type
- P-0-0809, Properties of charging circuit
- P-0-0859, Data of internal braking resistor
- P-0-1510, Circuit board code power section
- P-0-1519, Module code of power section
- P-0-3902, Command values for power section adjust
- P-0-3903, Adjust values of power section
- P-0-4058, Amplifier type data
- P-0-4059, Electric type data of power section

Error Messages

Cause	Remedy
One of power section parameters is invalid (e.g. checksum error) or contains inadmissible value.	Check content of list "S-0-0021, IDN list of invalid operating data for communication phase 2", write down IDNs it contains (IDNs/parameters) and then please contact Rexroth service department.
As of MPx04VRS: Incorrect parameter setting when using device "HAC01" (SERCOS analog converter).	Check/correct settings in "P-0-0860, Converter configuration" (bit 15); reboot device "HAC01" after having changed parameter setting.
Control section and/or power section defective.	Replace drive controller



The replacement of the entire drive controller is described in the Project Planning Manual for the power section.

F8091 - Attributes **Display:** F8091
Ident N°: F8091

8.2.29 F8100 Error when initializing the parameter handling

Allocation	Contained in 02VRS:	«MPB»	«MPH»	«MPD»	
	Contained in 03VRS:	«MPB»	«MPH»	«MPD»	
	Contained in 04VRS:	«MPB»	«MPH»	«MPD»	
	Contained in 05VRS:	«MPB»	«MPH»	«MPD»	
	Contained in 06VRS:	«MPB»	«MPH»	«MPD»	«MPC»
	Contained in 07VRS:	«MPB»	«MPH»	«MPD»	«MPC»
	Contained in 08VRS:	«MPB»	«MPH»	«MPD»	«MPC»
	Supported by supply unit:	«-»			

During the initialization of the drive the control section is checked for correct function. An error was detected during this check.

Cause	Remedy
Control section configuration not allowed because an optional module (e.g. optional module 1...4, master communication,...) is not supported by firmware.	Switch drive off and on again. If error occurs again, replace control section (e.g. CSH01.1 or CDB01.1) by different control section with appropriate configuration. If necessary, contact our service department.
Firmware used is not suitable (e.g. MPH02VRS for double-axis control section), i.e. hardware and software do not match.	Select suitable firmware by means of Functional Description or Version Notes/Release Notes (see "supported control section configurations").
Hardware defect on control section	Switch drive off and on again. If error still occurs, contact our service department and, if necessary, replace control section or entire drive controller.



Only Rexroth service engineers or especially trained users are allowed to replace the control section. The replacement of the entire drive controller is described in the Project Planning Manual for the power section.

See also Functional Description of firmware "System Overview".

See also Project Planning Manual for control section, keyword "Type Code".

F8100 - Attributes **Display:** F8100
Ident N°: F8100

Error Messages

8.2.30 F8102 Error when initializing power section

Allocation	Contained in 02VRS:	«MPB»	«MPH»	«MPD»	
	Contained in 03VRS:	«MPB»	«MPH»	«MPD»	
	Contained in 04VRS:	«MPB»	«MPH»	«MPD»	
	Contained in 05VRS:	«MPB»	«MPH»	«MPD»	
	Contained in 06VRS:	«MPB»	«MPH»	«MPD»	«MPC»
	Contained in 07VRS:	«MPB»	«MPH»	«MPD»	«MPC»
	Contained in 08VRS:	«MPB»	«MPH»	«MPD»	«MPC»
	Supported by supply unit:	«-»			

During the initialization of the drive the power section is checked for correct function. An error was detected during this check.

Cause	Remedy
Hardware and firmware do not match	Check Firmware Release Notes or Firmware Version Notes and, if necessary, use latest firmware release.
Parameter "P-0-1510, Circuit board code power section" stored on power section is invalid or was incorrectly written.	Switch drive off and on again. If error occurs again, check content of "P-0-1510, Circuit board code power section" and contact our service department! Maybe you have to replace power section or entire drive controller.
Hardware defect on power section	Replace power section or entire drive controller.



Only Rexroth service engineers or especially trained users are allowed to replace the control section. The replacement of the entire drive controller is described in the Project Planning Manual for the power section.

F8102 - Attributes	Display:	F8102
	Ident N°:	F8102

8.2.31 F8118 Invalid power section/firmware combination

Allocation	Contained in 02VRS:	«MPB»	«MPH»	«MPD»	
	Contained in 03VRS:	«MPB»	«MPH»	«MPD»	
	Contained in 04VRS:	«MPB»	«MPH»	«MPD»	
	Contained in 05VRS:	«MPB»	«MPH»	«MPD»	
	Contained in 06VRS:	«MPB»	«MPH»	«MPD»	«MPC»
	Contained in 07VRS:	«MPB»	«MPH»	«MPD»	«MPC»
	Contained in 08VRS:	«MPB»	«MPH»	«MPD»	«MPC»
	Supported by supply unit:	«-»			

The power section is incompatible with the firmware used.

Cause	Remedy
Inappropriate firmware	Use firmware that matches power section
Inappropriate power section	Use power section that matches firmware
Operation without power section has been set, but firmware recognizes a power section	Check bit 15 in P-0-0860

F8118 - Attributes	Display:	F8118
	Ident N°:	F8118

8.2.32 F8120 Invalid control section/firmware combination

Allocation	Contained in 02VRS:	«MPB»	«MPH»	«MPD»	
	Contained in 03VRS:	«MPB»	«MPH»	«MPD»	
	Contained in 04VRS:	«MPB»	«MPH»	«MPD»	
	Contained in 05VRS:	«MPB»	«MPH»	«MPD»	
	Contained in 06VRS:	«MPB»	«MPH»	«MPD»	«MPC»
	Contained in 07VRS:	«MPB»	«MPH»	«MPD»	«MPC»
	Contained in 08VRS:	«MPB»	«MPH»	«MPD»	«MPC»
	Supported by supply unit:	«-»			

The control section is incompatible with the firmware used.

Cause	Remedy
During firmware replacement, there is an attempt to copy firmware to controller which does not match	Use firmware that matches control section
Inappropriate control section	Use control section that matches firmware
Safety technology incorrectly configured for double-axis device	Check control section configuration

F8120 - Attributes Display: F8120
 Ident N°: F8120

8.2.33 F8122 Control section defective

Allocation	Contained in 02VRS:	«MPB»	«MPH»	«MPD»	
	Contained in 03VRS:	«MPB»	«MPH»	«MPD»	
	Contained in 04VRS:	«MPB»	«MPH»	«MPD»	
	Contained in 05VRS:	«MPB»	«MPH»	«MPD»	
	Contained in 06VRS:	«MPB»	«MPH»	«MPD»	«MPC»
	Contained in 07VRS:	«MPB»	«MPH»	«MPD»	«MPC»
	Contained in 08VRS:	«MPB»	«MPH»	«MPD»	«MPC»
	Supported by supply unit:	«-»			

During the initialization of the control section an error occurred.

Cause	Remedy
Hardware of control section is defective	Replace control section or entire drive controller; use hardware configuration of same type



Only Rexroth service engineers or especially trained users are allowed to replace the control section. The replacement of the entire drive controller is described in the Project Planning Manual for the power section.

F8122 - Attributes Display: F8122
 Ident N°: F8122

8.2.34 F8129 Incorrect optional module firmware

Allocation	Contained in 02VRS:	«MPB»	«MPH»	«MPD»	
	Contained in 03VRS:	«MPB»	«MPH»	«MPD»	
	Contained in 04VRS:	«MPB»	«MPH»	«MPD»	
	Contained in 05VRS:	«MPB»	«MPH»	«MPD»	
	Contained in 06VRS:	«MPB»	«MPH»	«MPD»	«MPC»
	Contained in 07VRS:	«MPB»	«MPH»	«MPD»	«MPC»
	Contained in 08VRS:	«MPB»	«MPH»	«MPD»	«MPC»
	Supported by supply unit:	«-»			

The firmware of an optional module is defective.

Error Messages

Cause	Remedy
Firmware of an optional module programmed in invalid form – or - An error occurred during firmware update	Carry out firmware update (again). If error occurs repeatedly, it is necessary to replace control section or drive controller



Only Rexroth service engineers or especially trained users are allowed to replace the control section. The replacement of the entire drive controller is described in the Project Planning Manual for the power section.

F8129 - Attributes Display: F8129
 Ident N°: F8129

8.2.35 F8130 Firmware of option 2 of safety technology defective

Allocation	Contained in 02VRS:	«MPB»	«MPH»	«MPD»	
	Contained in 03VRS:	«-»	«-»	«-»	
	Contained in 04VRS:	«-»	«-»	«-»	
	Contained in 05VRS:	«-»	«-»	«-»	
	Contained in 06VRS:	«-»	«-»	«-»	«-»
	Contained in 07VRS:	«-»	«-»	«-»	«-»
	Contained in 08VRS:	«-»	«-»	«-»	«-»
	Supported by supply unit:	«-»			

The firmware of the optional safety technology module is defective.

Cause	Remedy
Programming of firmware for optional safety technology module is invalid	Make firmware update
An error occurred during firmware update	Restart firmware update. If error message is displayed again, replace control section with control section of same type, if you are authorized to do this! Otherwise entire drive controller has to be replaced.



Only Rexroth service engineers or especially trained users are allowed to replace the control section. The replacement of the entire drive controller is described in the Project Planning Manual for the power section.

F8130 - Attributes Display: F8130
 Ident N°: F8130

8.2.36 F8133 Error when checking interrupting circuits

Allocation	Contained in 02VRS:	«MPB»	«MPH»	«MPD»	
	Contained in 03VRS:	«MPB»	«MPH»	«MPD»	
	Contained in 04VRS:	«MPB»	«MPH»	«MPD»	
	Contained in 05VRS:	«MPB»	«MPH»	«MPD»	
	Contained in 06VRS:	«MPB»	«MPH»	«MPD»	«MPC»
	Contained in 07VRS:	«MPB»	«MPH»	«MPD»	«MPC»
	Contained in 08VRS:	«MPB»	«MPH»	«MPD»	«MPC»
	Supported by supply unit:	«-»			

In order to lock the output stage in a safe way when the safety technology has detected an error, the correct functioning of the interrupting circuit is cyclically checked. This is done on the one hand during the actions "release output stage" and "lock output stage", on the other hand statically while the

Error Messages

output stage is being released or locked. The corresponding hardware realization ensures that this is possible without repercussion on the PWM control signals.

The drive immediately goes torque-free. Automatic switching to "safety related standstill" (up to MPx06) or "Safe stop 1" (as of MPx07) takes place and the output stage is switched off via one channel. All poles of the mains contactor are switched off.



Safety is not acknowledged; i.e., "safety technology status output controller" in "P-0-3214, Safety technology status word, channel 1" was cleared/reset or the diagnostic input/output EA10n (channel 2) was set depending on the parameterization in "P-0-3210, Safety technology configuration".

Cause	Remedy
An error was detected during check of interrupting circuit	Switch power supply off and on again. If error occurs repeatedly, replace control section or entire drive controller



Only Rexroth service engineers or especially trained users are allowed to replace the control section. The replacement of the entire drive controller is described in the Project Planning Manual for the power section.

F8133 - Attributes Display: F8133
 Ident N°: F8133

8.2.37 F8134 SBS: Fatal error

Allocation	Contained in 02VRS:	«-»	«-»	«-»	
	Contained in 03VRS:	«-»	«-»	«-»	
	Contained in 04VRS:	«-»	«-»	«-»	
	Contained in 05VRS:	«MPB»	«MPH»	«MPD»	
	Contained in 06VRS:	«MPB»	«MPH»	«MPD»	«MPC»
	Contained in 07VRS:	«MPB»	«MPH»	«MPD»	«MPC»
	Contained in 08VRS:	«MPB»	«MPH»	«MPD»	«MPC»
	Supported by supply unit:	«-»			



Up to MPx06, the name of this diagnostic message was "F8134 Safety related holding system: Fatal error".

A check detected that the motor holding brake or the redundant holding brake, with the drive torque-free, has not been controlled for the purpose of applying it or has not been applied.

Cause	Remedy
Error in wiring between control section, control module and redundant holding brake	Check wiring
Hardware error of control module or error in mechanical system of redundant holding brake	Replace hardware
Error in parameterization	Check parameterization

F8134 - Attributes Display: F8134
 Ident N°: F8134

Error Messages

8.2.38 F8135 SMD: Velocity exceeded

Allocation	Contained in 02VRS:	«-»	«-»	«-»	
	Contained in 03VRS:	«-»	«-»	«-»	
	Contained in 04VRS:	«MPB»	«MPH»	«MPD»	
	Contained in 05VRS:	«MPB»	«MPH»	«MPD»	
	Contained in 06VRS:	«MPB»	«MPH»	«MPD»	«MPC»
	Contained in 07VRS:	«MPB»	«MPH»	«MPD»	«MPC»
	Contained in 08VRS:	«MPB»	«MPH»	«MPD»	«MPC»
	Supported by supply unit:	«-»			



Up to MPx06, the name of this diagnostic message was "F8135 Velocity exceeded with trend monitoring".

During the stopping process, the drive is not able to come to standstill within the parameterized limits.

Ursache	Abhilfe
In the case of drive-controlled transition to standstill from normal operation, special mode motion or in the case of error, drive is not able to reach standstill with deceleration parameterized in "P-0-3282, Safely-monitored deceleration".	Select useful value for parameter "P-0-3282, Safely-monitored deceleration"

F8135 - Attributes Display: F8135
 Ident N°: F8135

8.2.39 F8140 Fatal CCD error

Allocation	Contained in 02VRS:	«-»	«-»	«-»	
	Contained in 03VRS:	«-»	«-»	«-»	
	Contained in 04VRS:	«-»	«MPH»	«-»	
	Contained in 05VRS:	«-»	«MPH»	«-»	
	Contained in 06VRS:	«-»	«-»	«-»	«MPC»
	Contained in 07VRS:	«-»	«-»	«-»	«MPC»
	Contained in 08VRS:	«-»	«-»	«-»	«MPC»
	Supported by supply unit:	«-»			

Cause	Remedy
"Error reaction active" has been set in "P-0-1600, CCD: configuration" and an F8 error occurred in a slave.	Localize faulty slave and remove cause of error for this slave.



The CCD master reacts with torque disable.

See also Functional Description of firmware "Cross Communication (CCD)".

F8140 - Attributes Display: F8140
 Ident N°: F8140

8.2.40 F8201 Safety technology basic initialization incorrect

Allocation	Contained in 02VRS:	«MPB»	«MPH»	«MPD»	
	Contained in 03VRS:	«MPB»	«MPH»	«MPD»	
	Contained in 04VRS:	«MPB»	«MPH»	«MPD»	
	Contained in 05VRS:	«MPB»	«MPH»	«MPD»	
	Contained in 06VRS:	«MPB»	«MPH»	«MPD»	«MPC»
	Contained in 07VRS:	«MPB»	«MPH»	«MPD»	«MPC»
	Contained in 08VRS:	«MPB»	«MPH»	«MPD»	«MPC»
	Supported by supply unit:	«-»			

In the booting phase of the drive, a basic initialization is carried out on both safety technology channels.

Cause	Remedy
Basic initialization on channel 2 is incorrect or internal command was aborted with timeout - or - Error in safety memory	Execute command "C0720 Load defaults procedure command (safety technology) " and reset optional safety technology module (switch control voltage off and then on again)
Up to MPx03: Error in parameterization, i.e. double assignment of inputs at channel 2 (e.g. mode selector parameterized twice)	Check assignment of inputs in "P-0-3211, Safety technology I/O control word, channel 2"
As of MPx07: Incompatible logicware versions were detected	Replace firmware
As of MPx07: Hardware version is insufficient	Integrated safety technology, based on the standard IEC61508, can only be operated with sufficient hardware version: In P-0-1520, "S2" must have been entered as safety option. Error was generated because hardware version is insufficient. ⇒ Replace hardware.
Hardware error	Replace hardware



When using the optional module "safety technology I/O" (S1) (up to MPx06) or "Safe Motion" (S2) (as of MPx07), you can, in addition to the error message, obtain detailed information with regard to the cause of the error or the error location. For this purpose, evaluate parameter "P-0-3219, Diagnostic safety technology message".

Up to MPx06: See "Extended Diagnosis (P-0-3219)".

As of MPx07: See "Extended Diagnosis (P-0-3219) as of MPx07".



Only Rexroth service engineers or especially trained users are allowed to replace the control section. The replacement of the entire drive controller is described in the Project Planning Manual for the power section.

Only Rexroth service engineers are allowed to replace options of the control section.

F8201 - Attributes **Display:** F8201
 Ident N°: F8201

8.2.41 F8203 Safety technology configuration parameter invalid

Allocation	Contained in 02VRS:	«MPB»	«MPH»	«MPD»	
	Contained in 03VRS:	«MPB»	«MPH»	«MPD»	
	Contained in 04VRS:	«MPB»	«MPH»	«MPD»	
	Contained in 05VRS:	«MPB»	«MPH»	«MPD»	
	Contained in 06VRS:	«MPB»	«MPH»	«MPD»	«MPC»
	Contained in 07VRS:	«MPB»	«MPH»	«MPD»	«MPC»
	Contained in 08VRS:	«MPB»	«MPH»	«MPD»	«MPC»
	Supported by supply unit:	«-»			

All safety technology parameters are protected against incorrect input - which is similar to the use of a password - because they have to be input twice.

Error Messages

The time and control word parameters required for initialization are read from their parameter memory after the drive has been switched on and the two double elements are compared.

- P-0-3210, Safety technology configuration
- P-0-3211, Safety technology I/O configuration list, channel 2
- P-0-3220, Tolerance time transition from normal operation
- P-0-3221, Max. tolerance time for different channel states
- P-0-3222, Max. activation time of enabling control
- P-0-3223, Time interval for dynamization of safety function selection
- P-0-3224, Duration of dynamization pulse of safety function selection
- P-0-3225, Tolerance time transition from safe operation
- P-0-3240, Configuration of safe motion 1
- P-0-3250, Configuration of safe motion 2
- P-0-3260, Configuration of safe motion 3
- P-0-3270, Configuration of safe motion 4
- "P-0-3290, PROFIsafe: F_Destination_Address" (not MPx02VRS!)
- "P-0-3291, PROFIsafe: F_Source_Address" (not MPx02VRS!)

The comparison showed that not all of the double elements are identical.



Switching to operating mode is impossible.

Cause	Remedy
A memory cell was overwritten by mistake	Reset command "C0720 Load defaults procedure command (safety technology) " and optional safety technology module (switch control voltage off and then on again) Note: Command "C0720 Load defaults procedure command (safety technology)" overwrites user-defined safety technology settings! Only use this command if you want to commission safety technology again
Firmware defect on optional safety technology module	If command error occurs repeatedly, safety technology firmware has to be replaced
Hardware defect on optional safety technology module	If command error occurs repeatedly, optional safety technology module has to be replaced

F8203 - Attributes

Display:
Ident N°:

F8203
F8203

8.2.42 F8813 Connection error mains choke

Allocation	Contained in 02VRS:	«-»	«-»	«-»	
	Contained in 03VRS:	«-»	«-»	«-»	
	Contained in 04VRS:	«-»	«-»	«-»	
	Contained in 05VRS:	«-»	«-»	«-»	
	Contained in 06VRS:	«-»	«-»	«-»	«-»
	Contained in 07VRS:	«-»	«-»	«-»	«-»
	Contained in 08VRS:	«-»	«-»	«-»	«-»
	Supported by supply unit:	«H MV»			

After the power supply had been switched on, a wiring error of the mains choke (e.g. incorrect phase sequence of the mains phases) was detected.

Error Messages

Cause	Remedy
Mains choke was incorrectly connected	Check and correct connection of mains choke; connections to mains choke must be as short as possible and twisted → See also documentation "Drive System, Project Planning Manual", chapter "Connection to Mains Choke and Mains Filter" (for an overview of reference documentations on the drive system and the system components, see: "Reference Documentations")

F8813 - Attributes Display: F8813
 Ident N°: F8813

8.2.43 F8830 Power section error

Allocation	Contained in 02VRS:	«-»	«-»	«-»	
	Contained in 03VRS:	«-»	«-»	«-»	
	Contained in 04VRS:	«-»	«-»	«-»	
	Contained in 05VRS:	«-»	«-»	«-»	
	Contained in 06VRS:	«MPB»	«MPH»	«MPD»	«MPC»
	Contained in 07VRS:	«MPB»	«MPH»	«MPD»	«MPC»
	Contained in 08VRS:	«MPB»	«MPH»	«MPD»	«MPC»
	Supported by supply unit:	«-»			

Cause	Remedy
Hardware error in power section	Switch device off and then on again. If error occurs repeatedly, replace device

F8830 - Attributes Display: F8830
 Ident N°: F8830

8.2.44 F8838 Overcurrent external braking resistor

Allocation	Contained in 02VRS:	«MPB»	«MPH»	«MPD»	
	Contained in 03VRS:	«MPB»	«MPH»	«MPD»	
	Contained in 04VRS:	«MPB»	«MPH»	«MPD»	
	Contained in 05VRS:	«MPB»	«MPH»	«MPD»	
	Contained in 06VRS:	«-»	«-»	«-»	«-»
	Contained in 07VRS:	«-»	«-»	«-»	«-»
	Contained in 08VRS:	«-»	«-»	«-»	«-»
	Supported by supply unit:	«-»			

The error F8838 is generated when the current in the braking resistor circuit is rising in an inadmissible way.

Cause	Remedy
Resistance value of connected braking resistor is too low.	Connect braking resistor unit with higher resistance value (take specification into account!).
Short circuit at braking resistor connection.	Remove short circuit

See also Functional Description of firmware " Power Supply".

F8838 - Attributes Display: F8838
 Ident N°: F8838

Error Messages

8.3 Safety Technology Errors (F7xxx)

8.3.1 Behavior in Case of Safety Technology Errors

NC-controlled stopping is not possible in case of safety technology errors (F7xxx) ("P-0-0117, Activation of control unit reaction on error" is ineffective).



The behavior of the drive (error reaction) in case of safety technology errors was extended and can be set as of firmware MPx03V20.

Up to MPx-03V18

Up to the firmware MPx-03V18, the drive is shut down as quickly as possible in case of safety technology errors (F7xxx), i.e., independently of the settings in "P-0-0119, Best possible deceleration"; the drive is brought to a standstill by a velocity command value reset (see also MPx02 and MPx03 Functional Descriptions, index entry "Error reaction").

As of Firmware MPx-03V20

As of firmware MPx-03V20, the error reaction in case of safety technology errors (F7xxx) can be parameterized via the configuration bit "reaction to F7 error" in "P-0-3210, Safety technology configuration"; the error reaction "velocity command value reset" is activated by default but can be deactivated so that the drive immediately goes torque-free when an F7 error occurs.



The F7 error reaction "torque disable" should only be used when forced deceleration by a velocity command value reset generally causes problems, e.g. in case of mechanically coupled axes.

The machine manufacturer is responsible for the F7 error reaction "torque disable" and his risk analysis has to show this responsibility.

As of Firmware MPx-05

As of firmware MPx-05, "P-0-3210, Safety technology configuration" and "P-0-0119, Best possible deceleration" can be used to configure the error reaction "Velocity command value reset while maintaining the emergency halt deceleration (S-0-0429)".

At the end of each F7 error reaction, the drive goes torque-free and the output stage is locked via two channels after the time entered in "P-0-3220, Tolerance time transition from normal operation" or "P-0-3225, Tolerance time transition from safe operation" is over.

Commissioning Steps

After a safety technology error (F7xxx) has occurred, the drive can only be put into operation again when:

1. The actual cause of the error was recognized and removed (e.g. incorrect parameterization of velocity thresholds or time windows).



When using the optional module "safety technology I/O" (S1) (up to MPx06) or "Safe Motion" (S2) (as of MPx07), you can, in addition to the error message, obtain detailed information with regard to the cause of the error or the error location. For this purpose, evaluate parameter "P-0-3219, Diagnostic safety technology message".

Up to MPx06: See "Extended Diagnosis (P-0-3219)".

As of MPx07: See "Extended Diagnosis (P-0-3219) as of MPx07".

2. The error message was cleared by the error clearing command (cf. "S-0-0099, C0500 Reset class 1 diagnostics").
3. The drive is in the operating mode again and power was switched on again ("Ab").

4. Drive enable was switched on again (0-1 edge).



In case safety technology errors are occurring repeatedly, contact our service department as operating the drive then is no longer allowed.

8.3.2 F7010 Safely-limited increment exceeded

Allocation	Contained in 02VRS:	«MPB»	«MPH»	«MPD»	
	Contained in 03VRS:	«MPB»	«MPH»	«MPD»	
	Contained in 04VRS:	«MPB»	«MPH»	«MPD»	
	Contained in 05VRS:	«MPB»	«MPH»	«MPD»	
	Contained in 06VRS:	«MPB»	«MPH»	«MPD»	«MPC»
	Contained in 07VRS:	«MPB»	«MPH»	«MPD»	«MPC»
	Contained in 08VRS:	«MPB»	«MPH»	«MPD»	«MPC»
	Supported by supply unit:	«-»			



Up to MPx06, the name of this diagnostic message was "F7010 Safety related limited increment exceeded".

In the special mode "safe motion" with configured safety function "Safely-limited increment", the monitoring function makes sure that the values do not leave the parameterized position window (increment).

The bipolar position window is activated with the start of the special mode. For the duration of the special mode, the drive can freely move within the limits of the position window.

Cause	Remedy
At least one of the position windows relevant for special mode "safe motion" has been incorrectly parameterized	Check parameterization of position windows and adjust it to desired travel targets. Position window: <ul style="list-style-type: none"> • "P-0-3243, Safely-limited increment 1" or • "P-0-3253, Safely-limited increment 2" or • "P-0-3263, Safely-limited increment 3" or • "P-0-3273, Safety related limited increment 4" After troubleshooting, start command "S-0-0099, C0500 Reset class 1 diagnostics" in order to clear error an then set drive enable again
Command value input is incorrect; i.e. drive moves to invalid target positions	Check command value input in control unit and adjust target positions according to travel range or required target positions. After troubleshooting, start command "S-0-0099, C0500 Reset class 1 diagnostics" in order to clear error an then set drive enable again

See also documentation

- **Up to MPx06:** "Integrated Safety Technology"
- **As of MPx07:** "Integrated Safety Technology According to IEC61508"

F7010 - Attributes
 Display: F7010
 Ident N°: F7010

Error Messages

8.3.3 F7011 Safely-monitored position, exceeded in pos. direction

Allocation	Contained in 02VRS:	«MPB»	«MPH»	«MPD»	
	Contained in 03VRS:	«MPB»	«MPH»	«MPD»	
	Contained in 04VRS:	«MPB»	«MPH»	«MPD»	
	Contained in 05VRS:	«MPB»	«MPH»	«MPD»	
	Contained in 06VRS:	«MPB»	«MPH»	«MPD»	«MPC»
	Contained in 07VRS:	«MPB»	«MPH»	«MPD»	«MPC»
	Contained in 08VRS:	«MPB»	«MPH»	«MPD»	«MPC»
	Supported by supply unit:	«-»			



Up to MPx06, the name of this diagnostic message was "F7011 Safety rel. position limit val., exc. in pos. dir.".

In special mode "safe motion" with configured safety function "safety related limited absolute position" (up to MPx06) or "Safely-monitored position" (as of MPx07), the parameterized position limit value was exceeded in positive direction.

Cause	Remedy
In safety function "special mode motion", value parameterized in parameter <ul style="list-style-type: none"> "P-0-3241, Safely-monitored position 1, positive" or "P-0-3251, Safely-monitored position 2, positive" was exceeded 	Check command value input and adjust it according to parameterized position limit values – or – Check parameter setting and change it, if necessary. Afterwards start command "S-0-0099, C0500 Reset class 1 diagnostics" in order to clear error and then set drive enable again.

F7011 - Attributes Display: F7011
 Ident N°: F7011

8.3.4 F7012 Safely-monitored position, exceeded in neg. direction

Allocation	Contained in 02VRS:	«MPB»	«MPH»	«MPD»	
	Contained in 03VRS:	«MPB»	«MPH»	«MPD»	
	Contained in 04VRS:	«MPB»	«MPH»	«MPD»	
	Contained in 05VRS:	«MPB»	«MPH»	«MPD»	
	Contained in 06VRS:	«MPB»	«MPH»	«MPD»	«MPC»
	Contained in 07VRS:	«MPB»	«MPH»	«MPD»	«MPC»
	Contained in 08VRS:	«MPB»	«MPH»	«MPD»	«MPC»
	Supported by supply unit:	«-»			



Up to MPx06, the name of this diagnostic message was "F7012 Safety rel. position limit val., exc. in neg. dir.".

In the special mode "safe motion" with configured safety function "safety related limited absolute position" (up to MPx06) or "Safely-monitored position" (as of MPx07), the parameterized position limit value was exceeded in negative direction.

Cause	Remedy
In special mode "safe motion", value parameterized in <ul style="list-style-type: none"> "P-0-3242, Safely-monitored position 1, negative" or "P-0-3252, Safely-monitored position 2, negative" was exceeded. 	Check command value input and adjust it according to parameterized position limit values – or – Check parameter setting and change it, if necessary. Then start command "S-0-0099, C0500 Reset class 1 diagnostics" in order to clear error and then set drive enable again.

F7012 - Attributes Display: F7012
 Ident N°: F7012

8.3.5 F7013 Safely-limited speed exceeded

Allocation	Contained in 02VRS:	«MPB»	«MPH»	«MPD»	
	Contained in 03VRS:	«MPB»	«MPH»	«MPD»	
	Contained in 04VRS:	«MPB»	«MPH»	«MPD»	
	Contained in 05VRS:	«MPB»	«MPH»	«MPD»	
	Contained in 06VRS:	«MPB»	«MPH»	«MPD»	«MPC»
	Contained in 07VRS:	«MPB»	«MPH»	«MPD»	«MPC»
	Contained in 08VRS:	«MPB»	«MPH»	«MPD»	«MPC»
	Supported by supply unit:	«-»			



Up to MPx06, the name of this diagnostic message was "F7013 Velocity threshold exceeded".

In the special mode "safe motion", a parameterized velocity threshold was exceeded.

Cause	Remedy
In special mode "safe motion", velocity threshold parameterized in <ul style="list-style-type: none"> "P-0-3244, Safely-limited speed 1" or "P-0-3254, Safely-limited speed 2" or "P-0-3264, Safely-limited speed 3" or "P-0-3274, Safely-limited speed 4" was exceeded 	Check command value input and adjust it according to parameter setting - or - Check parameter setting and change it, if necessary. Afterwards start command "S-0-0099, C0500 Reset class 1 diagnostics" in order to clear error and then set drive enable again

F7013 - Attributes Display: F7013
 Ident N°: F7013

8.3.6 F7014 Timeout safely-monitored transient oscillation

Allocation	Contained in 02VRS:	«MPB»	«MPH»	«MPD»	
	Contained in 03VRS:	«MPB»	«MPH»	«MPD»	
	Contained in 04VRS:	«MPB»	«MPH»	«MPD»	
	Contained in 05VRS:	«MPB»	«MPH»	«MPD»	
	Contained in 06VRS:	«MPB»	«MPH»	«MPD»	«MPC»
	Contained in 07VRS:	«MPB»	«MPH»	«MPD»	«MPC»
	Contained in 08VRS:	«MPB»	«MPH»	«MPD»	«MPC»
	Supported by supply unit:	«-»			

Error Messages

Cause	Remedy
In special mode "safe motion" (with activated safety function "Safely-monitored transient oscillation") the "Safely-limited speed" (P-0-3247, P-0-3257, P-0-3267 or P-0-3277) was exceeded longer than the tolerance time set (P-0-3248, P-0-3258, P-0-3268 or P-0-3278).	Check command value input and adjust it according to parameter setting - or - Check parameter setting and change it, if necessary. Afterwards start command "S-0-0099, C0500 Reset class 1 diagnostics" in order to clear error and then set drive enable again

F7014 - Attributes Display: F7014
 Ident N°: F7014

8.3.7 F7020 Safe maximum speed exceeded

Allocation	Contained in 02VRS:	«MPB»	«MPH»	«MPD»	
	Contained in 03VRS:	«MPB»	«MPH»	«MPD»	
	Contained in 04VRS:	«MPB»	«MPH»	«MPD»	
	Contained in 05VRS:	«MPB»	«MPH»	«MPD»	
	Contained in 06VRS:	«MPB»	«MPH»	«MPD»	«MPC»
	Contained in 07VRS:	«MPB»	«MPH»	«MPD»	«MPC»
	Contained in 08VRS:	«MPB»	«MPH»	«MPD»	«MPC»
	Supported by supply unit:	«-»			

When monitoring of the safe maximum speed has been configured (see "P-0-3239, Configuration of global safety technology functions"), the drive in normal operation and in special mode monitors the current actual velocity.

When the velocity threshold parameterized in "P-0-3234, Safe maximum speed" is exceeded, the error F7020 is generated.

Cause	Remedy
Velocity threshold was incorrectly parameterized	Check and, if necessary, increase parameter setting of "P-0-3234, Safe maximum speed"
Incorrect command value input; i.e. velocity command value too high	Check command value input in control unit or, for drive-internal interpolation, check parameterized positioning data (cf. "S-0-0259, Positioning velocity" or "P-0-4007, Positioning block velocity")
With active safety function "Safely-limited position", axis was moved without safe reference faster than 20 % of safe maximum speed	Home axis safely - or - Do not exceed allowed speed

Description of error reaction: "Behavior in the Case of Safety Technology Errors"

See also documentation

- **Up to MPx06:** "Integrated Safety Technology"
- **As of MPx07:** "Integrated Safety Technology According to IEC61508"

F7020 - Attributes Display: F7020
 Ident N°: F7020

Error Messages

8.3.10 F7031 Incorrect direction of motion

Allocation	Contained in 02VRS:	«MPB»	«MPH»	«MPD»	
	Contained in 03VRS:	«MPB»	«MPH»	«MPD»	
	Contained in 04VRS:	«MPB»	«MPH»	«MPD»	
	Contained in 05VRS:	«MPB»	«MPH»	«MPD»	
	Contained in 06VRS:	«MPB»	«MPH»	«MPD»	«MPC»
	Contained in 07VRS:	«MPB»	«MPH»	«MPD»	«MPC»
	Contained in 08VRS:	«MPB»	«MPH»	«MPD»	«MPC»
	Supported by supply unit:	«-»			

While safety function "Safe direction" is executed, the drive is monitored with regard to whether it inadmissibly moves against the parameterized direction of motion by more than the distance parameterized in "P-0-3232, Standstill window for safe direction". If yes, error F7031 is generated.

Cause	Remedy
Incorrect command value input	Adjust command value input according to parameterized direction of motion and monitoring window "P-0-3232, Standstill window for safe direction"
Incorrect parameterization of direction of motion	<p>Check parameter setting for direction of motion and change it, if necessary.</p> <ul style="list-style-type: none"> • "P-0-3239, Configuration of global safety technology functions" or • "P-0-3240, Configuration of safe motion 1" or • "P-0-3250, Configuration of safe motion 2" or • "P-0-3260, Configuration of safe motion 3" or • "P-0-3270, Configuration of safe motion 4"
Incorrect parameterization of "P-0-3232, Standstill window for safe direction"	Check parameterization of "P-0-3232, Standstill window for safe direction" and change it, if necessary

F7031 - Attributes Display: F7031
 Ident N°: F7031

8.3.11 F7040 Validation error parameterized - effective threshold

Allocation	Contained in 02VRS:	«MPB»	«MPH»	«MPD»	
	Contained in 03VRS:	«MPB»	«MPH»	«MPD»	
	Contained in 04VRS:	«MPB»	«MPH»	«MPD»	
	Contained in 05VRS:	«MPB»	«MPH»	«MPD»	
	Contained in 06VRS:	«MPB»	«MPH»	«MPD»	«MPC»
	Contained in 07VRS:	«MPB»	«MPH»	«MPD»	«MPC»
	Contained in 08VRS:	«MPB»	«MPH»	«MPD»	«MPC»
	Supported by supply unit:	«-»			

A cyclic check is run in order to find out whether the thresholds in the internal monitoring functions comply with the values parameterized in the safety memory. The check detects errors that can occur due to subsequent change of scaling or accidental overwriting. The values are required for all safety monitoring functions and are of fundamental importance for the functioning of safety technology.

Cause	Remedy
Safety parameters were changed without afterwards having been synchronized	Execute "P-0-3204, C3000 Synchronize and store safety technology IDN command" (channel 2 applies parameters of channel 1; internal values are recalculated and loaded). Note: Executing the command "C3000 Synchronize and store safety technology IDN" increases the change counter of the safety technology memory (P-0-3201). It is therefore necessary to carry out the acceptance test again. Start command "S-0-0099, C0500 Reset class 1 diagnostics" in order to clear error an then set drive enable again.
Hardware defect causes incorrect parameter contents	Replace control section or entire drive controller



Only Rexroth service engineers or especially trained users are allowed to replace the control section. The replacement of the entire drive controller is described in the Project Planning Manual for the power section.

F7040 - Attributes Display: F7040
 Ident N°: F7040

8.3.12 F7041 Actual position value validation error

Allocation	Contained in 02VRS:	«MPB»	«MPH»	«MPD»	
	Contained in 03VRS:	«MPB»	«MPH»	«MPD»	
	Contained in 04VRS:	«-»	«-»	«-»	
	Contained in 05VRS:	«-»	«-»	«-»	
	Contained in 06VRS:	«-»	«-»	«-»	«-»
	Contained in 07VRS:	«-»	«-»	«-»	«-»
	Contained in 08VRS:	«-»	«-»	«-»	«-»
	Supported by supply unit:	«-»			

Cause	Remedy
Actual position values determined on channel 1 and channel 2 are differing	Start command "S-0-0099, C0500 Reset class 1 diagnostics" in order to clear error and then set drive enable again. If error occurs repeatedly, replace control section or entire drive controller.



Only Rexroth service engineers or especially trained users are allowed to replace the control section. The replacement of the entire drive controller is described in the Project Planning Manual for the power section.

F7041 - Attributes Display: F7041
 Ident N°: F7041

Error Messages

8.3.13 F7042 Validation error of safe operation mode

Allocation	Contained in 02VRS:	«MPB»	«MPH»	«MPD»	
	Contained in 03VRS:	«MPB»	«MPH»	«MPD»	
	Contained in 04VRS:	«MPB»	«MPH»	«MPD»	
	Contained in 05VRS:	«MPB»	«MPH»	«MPD»	
	Contained in 06VRS:	«MPB»	«MPH»	«MPD»	«MPC»
	Contained in 07VRS:	«MPB»	«MPH»	«MPD»	«MPC»
	Contained in 08VRS:	«MPB»	«MPH»	«MPD»	«MPC»
	Supported by supply unit:	«-»			

The active safety technology operating states of channel 1 and channel 2 are cyclically and via two channels checked for validity.

If the two channels differ for more than 5 seconds, the error F7042 is generated.

Cause	Remedy
Criteria for transition to new safety technology operating status selected have not been fulfilled in one channel; this channel remains in old status - the other channel already went to new safety technology operating status.	Check time, velocity or position thresholds relevant for respective transition and adjust them, if necessary.
Control section is defective	Replace control section or entire drive controller.



Only Rexroth service engineers or especially trained users are allowed to replace the control section. The replacement of the entire drive controller is described in the Project Planning Manual for the power section.

F7042 - Attributes	Display:	F7042
	Ident N°:	F7042

8.3.14 F7043 Error of output stage interlock

Allocation	Contained in 02VRS:	«MPB»	«MPH»	«MPD»	
	Contained in 03VRS:	«MPB»	«MPH»	«MPD»	
	Contained in 04VRS:	«MPB»	«MPH»	«MPD»	
	Contained in 05VRS:	«MPB»	«MPH»	«MPD»	
	Contained in 06VRS:	«MPB»	«MPH»	«MPD»	«MPC»
	Contained in 07VRS:	«MPB»	«MPH»	«MPD»	«MPC»
	Contained in 08VRS:	«MPB»	«MPH»	«MPD»	«MPC»
	Supported by supply unit:	«-»			

When the output stage is activated, the correct functioning of the output stage incl. control is checked. If an error is detected during the function check, the error F7043 is generated.

Cause	Remedy
Faulty output stage	Replace control section or entire drive controller
Incorrect control of output stage or error in feedback	Replace power section or entire drive controller



Only Rexroth service engineers or especially trained users are allowed to replace the control section or the power section. The replacement of the entire drive controller is described in the Project Planning Manual for the power section.

F7043 - Attributes	Display:	F7043
	Ident N°:	F7043

8.3.15 F7050 Time for stopping process exceeded

Allocation	Contained in 02VRS:	«MPB»	«MPH»	«MPD»	
	Contained in 03VRS:	«MPB»	«MPH»	«MPD»	
	Contained in 04VRS:	«MPB»	«MPH»	«MPD»	
	Contained in 05VRS:	«MPB»	«MPH»	«MPD»	
	Contained in 06VRS:	«MPB»	«MPH»	«MPD»	«MPC»
	Contained in 07VRS:	«MPB»	«MPH»	«MPD»	«MPC»
	Contained in 08VRS:	«MPB»	«MPH»	«MPD»	«MPC»
	Supported by supply unit:	«-»			

During the transition of the drive from normal operation to a special mode "safe standstill" [or to "drive interlock" (up to MPx06)/to "Safe stop 1 (Emergency stop)" (as of MPx07)], the following check is run:

After the duration entered in

- "P-0-3220, Tolerance time transition from normal operation" or
- "P-0-3225, Tolerance time transition from safe operation"

is over, the actual velocity is checked with regard to the velocity threshold entered in "P-0-3233, Velocity threshold for safe standstill".



The drive can also be shut down in an NC-controlled way (cf. "P-0-3210, Safety technology configuration").

Cause	Remedy
Parameter setting in P-0-3220 or P-0-3225 for NC-controlled transition is incorrect	Check parameter setting of "P-0-3220, Tolerance time transition from normal operation" or "P-0-3225, Tolerance time transition from safe operation" and correct it accordingly
Drive enable is still set	Make sure that drive enable is removed
"NC-controlled stopping process" was activated by mistake	Check parameter setting of "P-0-3210, SI-Konfiguration" and correct it accordingly; i.e. activate "drive-controlled stopping process"
Parameterized deceleration is too low or not adjusted to parameterized tolerance time	For drive-controlled transition, stopping process takes place via "P-0-0119, Best possible deceleration" so that error reaction parameterized in drive has to be checked. For NC-controlled transition, check deceleration parameterized in control unit.

See also documentation

- **Up to MPx06:** "Integrated Safety Technology"
- **As of MPx07:** "Integrated Safety Technology According to IEC61508"

F7050 - Attributes	Display:	F7050
	Ident N°:	F7050

8.3.16 F7051 Safely-monitored deceleration exceeded

Allocation	Contained in 02VRS:	«-»	«-»	«-»	
	Contained in 03VRS:	«MPB»	«MPH»	«MPD»	
	Contained in 04VRS:	«MPB»	«MPH»	«MPD»	
	Contained in 05VRS:	«MPB»	«MPH»	«MPD»	
	Contained in 06VRS:	«MPB»	«MPH»	«MPD»	«MPC»
	Contained in 07VRS:	«MPB»	«MPH»	«MPD»	«MPC»
	Contained in 08VRS:	«MPB»	«MPH»	«MPD»	«MPC»
	Supported by supply unit:	«-»			

Error Messages



Up to MPx06, the name of this diagnostic message was "F7051 Safety related deceleration exceeded".

Safety function "Safely-monitored stopping process" is active (P-0-3210, bit 13="1"). The drive generated error F7051 because a new safety technology operating status was selected or an error of category F3xxx occurred and the drive is not able to reach the new target velocity/standstill within the monitoring time configured.

Cause	Remedy
If transitions between safety technology operating states are NC-controlled (P-0-3210, bit 4="0"), deceleration caused by NC is insufficient	Adjust command value input (deceleration caused by NC) to values parameterized in P-0-3220/P-0-3225 Adjust P-0-3226
If transitions between safety technology operating states are drive-controlled (P-0-3210, bit 4="1"), deceleration caused by drive is insufficient	Check parameterization of drive deceleration (P-0-0119) Check torque limitation
If "drive reaction to errors of category F3" is set, deceleration caused by drive is insufficient	Check parameterization of drive deceleration (P-0-0119) Check torque limitation
Actual velocity overshooting	<ul style="list-style-type: none"> Check controller setting and adjust if necessary As of MPx05: Check parameterization of P-0-3226 and P-0-3230
Selection of safety technology operating states during acceleration procedures	<ul style="list-style-type: none"> If possible avoid selecting safety technology operating states during acceleration procedures As of MPx07V10: Activate monitoring variant "Safely-monitored transient oscillation" (P-0-3210, bit 6="1").
Incorrect parameterization	Check parameter settings and change them, if necessary: <ul style="list-style-type: none"> P-0-3282, Safely-monitored deceleration "P-0-3220, Tolerance time transition from normal operation" or "P-0-3225, Tolerance time transition from safe operation" "P-0-3226, Delay Safely-monitored deceleration" (as of MPx05) "P-0-3210, Safety technology configuration", bit 6 (as of MPx07V10)

F7051 - Attributes

Display: F7051
Ident N°: F7051

8.4 Errors of Category F6xxx

8.4.1 Behavior in Case of Errors of Category F6xxx

Category F6xxx errors are as follows:

- Errors associated with an excess of a travel range that was defined beforehand via hardware or software switches (travel range errors).
- Fatal PLC errors
- CCD errors

Up to Firmware MPx04

Up to firmware MPx04, the drive is brought to a standstill as quickly as possible, independently of the settings in "P-0-0119, Best possible deceleration" and "P-0-0117, Activation of control unit reaction on error".

The deceleration type depends on the control type:

- **Closed loop:** Velocity command value reset
- **Open loop:** Subject to "P-0-0569, Maximum stator frequency slope")



The settings in "P-0-0118, Power supply, configuration" are still taken into account for travel range errors.

As of Firmware MPx05

As of firmware MPx05, the following error reactions may occur according to the settings in "P-0-0119, Best possible deceleration":

- Torque disable
- Velocity command value reset (emergency halt)
- Velocity command value reset while maintaining the emergency halt deceleration (S-0-0429)

At the end of the error reaction, the drive goes torque-free.

See also Functional Description of firmware "Error Reaction".

Commissioning Steps

The drive can only be put into operation again when:

1. The error reaction has been completed, i.e. the drive has stopped (v=0!).
2. The error message was cleared by the error clearing command (cf. "S-0-0099, C0500 Reset class 1 diagnostics").
3. The cause of the error was removed.
4. The drive is in operating mode again and power was switched on ("Ab").
5. Drive enable was switched on again (0-1 edge).

8.4.2 F6006 Incorrect initialization of effective master axis position

Allocation	Contained in 02VRS:	«-»	«-»	«-»	
	Contained in 03VRS:	«-»	«-»	«-»	
	Contained in 04VRS:	«-»	«-»	«-»	
	Contained in 05VRS:	«-»	«-»	«-»	
	Contained in 06VRS:	«-»	«-»	«-»	
	Contained in 07VRS:	«MPB»	«MPH»	«MPD»	«MPC»
	Contained in 08VRS:	«MPB»	«MPH»	«MPD»	«MPC»
	Supported by supply unit:	«-»			

Absolute initialization of the effective master axis position (P-0-0776) was not possible with activated operation mode "Position synchronization".

Cause	Remedy
When operation mode "Position synchronization" is activated, the resulting master axis position (P-0-0775) is multiplied by the electronic gear and the fine adjustments and is then limited to $2^{P-0-0084}$ increments (one revolution of the master axis). If the amount of the result that is not yet limited to $2^{P-0-0084}$ increments exceeds a value of $2^{31}-1$ increments, the effective master axis position (P-0-0776) is initialized incorrectly. In this case, the drive generates error F6006.	Adjust "P-0-0084, Number of bits per master axis revolution" - or - Select P-0-0775 with activated operation mode "Position synchronization" such that the requirement described under "Cause" is met (See also Functional Description "Master Axis Adjustment" / index entry "Gear function, electronic")

F6006 - Attributes **Display:** F6006
 Ident N°: F6006

Error Messages

8.4.3 F6010 PLC runtime error

Allocation	Contained in 02VRS:	«-»	«-»	«-»	
	Contained in 03VRS:	«MPB»	«MPH»	«-»	
	Contained in 04VRS:	«MPB»	«MPH»	«-»	
	Contained in 05VRS:	«MPB»	«MPH»	«-»	
	Contained in 06VRS:	«MPB»	«MPH»	«-»	«MPC»
	Contained in 07VRS:	«MPB»	«MPH»	«-»	«MPC»
	Contained in 08VRS:	«MPB»	«MPH»	«-»	«MPC»
	Supported by supply unit:	«-»			

The PLC integrated in the drive (Rexroth IndraMotion MLD) triggers the error F6010 in the case of runtime errors or task watchdog.

Error Reaction All tasks of the PLC are stopped. The drive is always shut down with velocity command value reset; i.e. the error reaction cannot be parameterized by the user.

Cause	Remedy (*1)
Runtime error in PLC program. Runtime monitor (watchdog) for a task has been activated. In this task, processing was not completed in the preset time.	Remove error by modifying program (correct a possibly existing infinite loop) The following actions according to application: <ul style="list-style-type: none"> • Increase task cycle time or • Increase watchdog time or reduce watchdog sensitivity (higher number) • Optimize program structure • Deactivate compilation option "Debugging" (increases processing velocity of PLC program)
Division by "0"	Modify PLC program: Remove division by "0"
Array limits exceeded	Modify PLC program: Check and correct array access
A subrange type has been exceeded	Modify PLC program: Eliminate incorrect assignment
Invalid access with a pointer in PLC program. As of MPx05, every access with pointer is monitored. Access outside of PLC data ranges cause this error	Modify PLC program: Eliminate incorrect assignment
Error in system event	Modify PLC program: Modify incorrect use or programming – on this topic, see notes in task configuration
PLC project too big for memory	Reduce project size or use control section with bigger code memory
Boot project could not be loaded, as it is incompatible with firmware	Recreate project with corresponding target
As of MPx05V08: Corrupt retain data were detected	Save P-0-1359 again and reload project. If error occurs repeatedly, replace control section or drive controller



Only Rexroth service engineers or especially trained users are allowed to replace the control section. The replacement of the entire drive controller is described in the Project Planning Manual for the power section.

(*1) Additional Notes on Troubleshooting

We distinguish the following cases of troubleshooting:

- For removing the error in a **freely programmed application**, it is necessary to modify the PLC program or the task configuration with the programming system IndraLogic.



When connecting the programming system IndraLogic to the drive-internal PLC or when starting the simulation (IndraLogic: "Online"- "Login"), the message window appears; it displays messages from the last compilation, check or comparison process.

- For a **technology function** made available by Bosch Rexroth, please see the corresponding documentation for instructions on troubleshooting.
- An extended diagnosis for determining the cause of the error is displayed in parameter "P-0-1365, PLC error message".

See also IndraLogic Online Help

See also documentation on error handling of IndraMotion MLD "Rexroth IndraMotion MLD"

F6010 - Attributes
 Display: F6010
 Ident N°: F6010

8.4.4 F6024 Maximum braking time exceeded

Allocation	Contained in 02VRS:	«MPB»	«MPH»	«MPD»	
	Contained in 03VRS:	«MPB»	«MPH»	«MPD»	
	Contained in 04VRS:	«MPB»	«MPH»	«MPD»	
	Contained in 05VRS:	«MPB»	«MPH»	«MPD»	
	Contained in 06VRS:	«MPB»	«MPH»	«MPD»	«MPC»
	Contained in 07VRS:	«MPB»	«MPH»	«MPD»	«MPC»
	Contained in 08VRS:	«MPB»	«MPH»	«MPD»	«MPC»
	Supported by supply unit:	«-»			

The drive checks automatically whether the motor, after drive enable has been switched off or when an error event occurs, was shut down within the delay time parameterized in "S-0-0273, Maximum drive off delay time".

If not, error F6024 is generated.

Closed-Loop "Shut down" means that the velocity of the motor is smaller than 10 rpm (rotary)/10 mm/min (linear) or the velocity of the motor is smaller than the standstill window (S-0-0124), when S-0-0124 is smaller than 10 rpm (rotary)/10 mm/min (linear).

- Open-Loop**
- **D.C. braking is deactivated: (P-0-0579 = "0"):**
 "Shut down" means that the calculated actual velocity of the motor is smaller than 10 rpm (rotary)/10 mm/min (linear).
 - **D.C. braking is activated: (P-0-0579 > "0"):**
 "Shut down" means that
 - the calculated actual velocity of the motor is smaller than 10 rpm (rotary)/10 mm/min (linear) **and**
 - the torque-producing current has fallen to 20% of its nominal value, **or**
 the D.C. braking time has elapsed (P-0-0579 = "0").

The error reaction of the drive depends on the brake type (see P-0-0525):

- **Servo brake**
 - The drive internally presets a velocity command value of "0" and the holding brake applies.
 - After the time preset in "S-0-0207, Drive off delay time" is over, the drive is torque- or force-free.
- **Main spindle brake**

Error Messages

- The drive goes torque- or force-free, the drive enable signal is switched off internally.
- The brake applies, when the velocity is smaller than 10 rpm (rotary)/10 mm/min (linear).

Cause	Remedy
Incorrect parameterization of "S-0-0273, Maximum drive off delay time" or "S-0-0372, Drive Halt acceleration bipolar"	Adjust delay time (S-0-0273) or acceleration (S-0-0372) to acceleration capacity of drive
Torque/force limitation incorrectly parameterized or current limitation active due to thermal overload	Check torque/force limitation and current limitation (see also Functional Description of firmware "Current and Torque/Force Limitation")
Incorrect motor connection	Check and, if necessary, correct motor connection
Hardware defect on power section	Replace control section or entire drive controller



Only Rexroth service engineers or especially trained users are allowed to replace the control section. The replacement of the entire drive controller is described in the Project Planning Manual for the power section.

See also Functional Description of firmware "Motor Holding Brake"

F6024 - Attributes

Display: F6024
Ident N°: F6024

8.4.5 F6028 Position limit value exceeded (overflow)

Allocation	Contained in 02VRS:	«-»	«-»	«-»	
	Contained in 03VRS:	«MPB»	«MPH»	«MPD»	
	Contained in 04VRS:	«MPB»	«MPH»	«MPD»	
	Contained in 05VRS:	«MPB»	«MPH»	«MPD»	
	Contained in 06VRS:	«MPB»	«MPH»	«MPD»	«MPC»
	Contained in 07VRS:	«MPB»	«MPH»	«MPD»	«MPC»
	Contained in 08VRS:	«MPB»	«MPH»	«MPD»	«MPC»
	Supported by supply unit:	«-»			

The drive provides a function for monitoring an allowed travel range by means of software limit switches that can be parameterized.



The travel range monitor has to be activated and parameterized via "S-0-0049, Positive position limit value", "S-0-0050, Negative position limit value" and "S-0-0055, Position polarities".

The drive reaction (fatal warning or error) in case the travel range is exceeded has to be parameterized in "P-0-0090, Travel range limit parameter".

Error Messages

Cause	Remedy
Command value set for drive causes axis position outside of positive travel range/position limit value ("S-0-0049, Positive position limit value" or "S-0-0050, Negative position limit value").	1. Clear error and switch power on. 2. Set drive enable and input a command value leading back to allowed travel range. Contact machine manufacturer in order to find out cause of incorrect command value.
"S-0-0049, Positive position limit value" or "S-0-0050, Negative position limit value" incorrectly parameterized	Check and, if necessary, correct parameter setting of "S-0-0049, Positive position limit value" or "S-0-0050, Negative position limit value".
When the position limit values are at the end of possible travel range (+/- "S-0-0278, Maximum travel range"), exceeding of travel range can no longer be unequivocally detected by means of actual position values. Therefore, overflow monitoring is carried out which generates error	Increase "S-0-0278, Maximum travel range" - or - Reduce position limit values so that defined deceleration is still possible within defined travel range.



The parameter "S-0-0057, Position window" is used to realize a hysteresis function for evaluating the position limit values.

See also Functional Description of firmware " Position Limitation/Travel Range Limit Switch".

F6028 - Attributes Display: F6028
 Ident N°: F6028

8.4.6 F6029 Positive position limit exceeded

Allocation	Contained in 02VRS:	«MPB»	«MPH»	«MPD»	
	Contained in 03VRS:	«MPB»	«MPH»	«MPD»	
	Contained in 04VRS:	«MPB»	«MPH»	«MPD»	
	Contained in 05VRS:	«MPB»	«MPH»	«MPD»	
	Contained in 06VRS:	«MPB»	«MPH»	«MPD»	«MPC»
	Contained in 07VRS:	«MPB»	«MPH»	«MPD»	«MPC»
	Contained in 08VRS:	«MPB»	«MPH»	«MPD»	«MPC»
	Supported by supply unit:	«-»			

The drive provides a function for monitoring an allowed travel range by means of software limit switches that can be parameterized.



The travel range monitor has to be activated and parameterized via "S-0-0049, Positive position limit value", "S-0-0050, Negative position limit value" and "S-0-0055, Position polarities".

The drive reaction (fatal warning or error) in case the travel range is exceeded has to be parameterized in "P-0-0090, Travel range limit parameter".

Cause	Remedy
Command value set for drive causes axis position outside of positive travel range/position limit value ("S-0-0049, Positive position limit value").	1. Clear error and switch power on. 2. Set drive enable and preset command value that leads back to the allowed travel range. Contact machine manufacturer in order to clarify cause of incorrect command value.
"S-0-0049, Positive position limit value" incorrectly parameterized.	Check and, if necessary, correct parameterization of "S-0-0049, Positive position limit value".

Error Messages



The "S-0-0057, Position window" parameter is used to realize a hysteresis function for evaluating the position limit values.

See also Functional Description of firmware " Position Limitation/Travel Range Limit Switch".

F6029 - Attributes

Display: F6029
Ident N°: F6029

8.4.7 F6030 Negative position limit exceeded

Allocation	Contained in 02VRS:	«MPB»	«MPH»	«MPD»	
	Contained in 03VRS:	«MPB»	«MPH»	«MPD»	
	Contained in 04VRS:	«MPB»	«MPH»	«MPD»	
	Contained in 05VRS:	«MPB»	«MPH»	«MPD»	
	Contained in 06VRS:	«MPB»	«MPH»	«MPD»	«MPC»
	Contained in 07VRS:	«MPB»	«MPH»	«MPD»	«MPC»
	Contained in 08VRS:	«MPB»	«MPH»	«MPD»	«MPC»
	Supported by supply unit:	«-»			

The drive provides a function for monitoring an allowed travel range by means of software limit switches that can be parameterized.



The travel range monitor has to be activated and parameterized via "S-0-0049, Positive position limit value", "S-0-0050, Negative position limit value" and "S-0-0055, Position polarities".

The drive reaction (fatal warning or error) in case the travel range is exceeded has to be parameterized in "P-0-0090, Travel range limit parameter".

Cause	Remedy
Command value set for drive causes axis position outside of negative travel range/position limit value ("S-0-0050, Negative position limit value").	<ol style="list-style-type: none"> 1. Clear error and switch power on 2. Set drive enable and preset command value that leads back to the allowed travel range. <p>Contact machine manufacturer in order to clarify cause of incorrect command value.</p>
"S-0-0050, Negative position limit value" incorrectly parameterized	Check and, if necessary, correct parameterization of "S-0-0050, Negative position limit value".



The "S-0-0057, Position window" parameter is used to realize a hysteresis function for evaluating the position limit values.

See also Functional Description of firmware " Position Limitation/Travel Range Limit Switch".

F6030 - Attributes

Display: F6030
Ident N°: F6030

8.4.8 F6034 Emergency-Stop activated

Allocation	Contained in 02VRS:	«MPB»	«MPH»	«MPD»	
	Contained in 03VRS:	«MPB»	«MPH»	«MPD»	
	Contained in 04VRS:	«MPB»	«MPH»	«MPD»	
	Contained in 05VRS:	«MPB»	«MPH»	«MPD»	
	Contained in 06VRS:	«MPB»	«MPH»	«MPD»	«MPC»
	Contained in 07VRS:	«MPB»	«MPH»	«MPD»	«MPC»
	Contained in 08VRS:	«MPB»	«MPH»	«MPD»	«MPC»
	Supported by supply unit:	«-»			

Error Messages

The drive provides a function for monitoring an E-Stop input (connection of an external hardware switch).

IndraDrive Mi: If "IndraDrive Mi" is used and the E-stop input is connected to the "KCU" electronic control system and parameter "P-0-0223, E-Stop input" is assigned to none of the digital inputs, the E-stop input of the "KCU" is monitored.



This monitor has to be activated and parameterized via "P-0-0008, Activation E-Stop function".

The error can only be cleared, when the selection of E-Stop is removed or the evaluation of E-Stop was switched off.

Cause	Remedy
E-Stop input was controlled (0 V at digital input)	Remove failure that caused E-Stop to be triggered and clarify cause of triggering
Incorrect parameterization of digital inputs and outputs on control section	Check configuration of digital inputs/outputs and correct it, if necessary
E-Stop switch or cable connection defective or incorrectly wired	Check function and wiring of E-Stop switch
Control section or digital inputs on control section defective	Replace control section or entire drive controller



Only Rexroth service engineers or especially trained users are allowed to replace the control section. The replacement of the entire drive controller is described in the Project Planning Manual for the power section.

See also Functional Description of firmware:

- "E-Stop Function"
- "Digital Inputs/Outputs"
- "Velocity Command Value Reset"

F6034 - Attributes Display: F6034
 Ident N°: F6034

8.4.9 F6042 Both travel range limit switches activated

Allocation	Contained in 02VRS:	«MPB»	«MPH»	«MPD»	
	Contained in 03VRS:	«MPB»	«MPH»	«MPD»	
	Contained in 04VRS:	«MPB»	«MPH»	«MPD»	
	Contained in 05VRS:	«MPB»	«MPH»	«MPD»	
	Contained in 06VRS:	«MPB»	«MPH»	«MPD»	«MPC»
	Contained in 07VRS:	«MPB»	«MPH»	«MPD»	«MPC»
	Contained in 08VRS:	«MPB»	«MPH»	«MPD»	«MPC»
	Supported by supply unit:	«-»			

The compliance with the allowed travel range is monitored on the hardware side via two travel range limit switches. When the travel range has been exceeded, one of the two limit switches is activated, if the limit switches were correctly mounted.

The error F6042 is generated, if

- the controller detects that both travel range limit switches have been simultaneously activated and
- exceeding the travel range is handled as an error (setting in "P-0-0090, Travel range limit parameter")

Error Messages

Cause	Remedy
Due to incorrect mounting, axis simultaneously activates both travel range limit switches	Mount travel range limit switches in such a way that they are activated shortly before axis end position is reached. Make sure the braking distance is sufficient.
Travel range limit switches were incorrectly connected	Connect travel range limit switches correctly; check compliance with switching logic set in "P-0-0090, Travel range limit parameter"
Switching logic of travel range limit switches does not correspond to realized wiring	Check switching logic with regard to realized wiring, adjust it in "P-0-0090, Travel range limit parameter" if necessary

F6042 - Attributes **Display:** F6042
Ident N°: F6042

8.4.10 F6043 Positive travel range limit switch activated

Allocation	Contained in 02VRS:	«MPB»	«MPH»	«MPD»	
	Contained in 03VRS:	«MPB»	«MPH»	«MPD»	
	Contained in 04VRS:	«MPB»	«MPH»	«MPD»	
	Contained in 05VRS:	«MPB»	«MPH»	«MPD»	
	Contained in 06VRS:	«MPB»	«MPH»	«MPD»	«MPC»
	Contained in 07VRS:	«MPB»	«MPH»	«MPD»	«MPC»
	Contained in 08VRS:	«MPB»	«MPH»	«MPD»	«MPC»
	Supported by supply unit:	«-»			

The drive provides a function for monitoring travel range limit switches (external hardware limit switches).



This monitor has to be activated and parameterized via "P-0-0090, Travel range limit parameter".

When the error F6043 occurs, the axis is shut down with velocity command value reset.

Cause	Remedy
Travel range limit switch situated in positive direction (see Project Planning Manual for motor) was activated because axis is outside of travel range that was defined by means of travel range limit switches.	<ol style="list-style-type: none"> 1. Clear error (reset button or error clearing command) and switch power on. 2. Set drive enable and preset command value that leads back to the allowed travel range.
Incorrect parameterization of digital inputs and outputs on control section	Correct configuration of digital inputs/outputs and correct it, if necessary.
Travel range limit switch or cable is defective or incorrectly wired	Check function and wiring of travel range limit switch.
Control section or digital inputs on control section defective	Replace control section or entire drive controller.



Only Rexroth service engineers or especially trained users are allowed to replace the control section. The replacement of the entire drive controller is described in the Project Planning Manual for the power section.

See also "E8043 Positive travel range limit switch activated".

See also Functional Description of firmware:

- " Position Limitation/Travel Range Limit Switch"
- " Digital Inputs/Outputs".

F6043 - Attributes Display: F6043
 Ident N°: F6043

8.4.11 F6044 Negative travel range limit switch activated

Allocation	Contained in 02VRS:	«MPB»	«MPH»	«MPD»	
	Contained in 03VRS:	«MPB»	«MPH»	«MPD»	
	Contained in 04VRS:	«MPB»	«MPH»	«MPD»	
	Contained in 05VRS:	«MPB»	«MPH»	«MPD»	
	Contained in 06VRS:	«MPB»	«MPH»	«MPD»	«MPC»
	Contained in 07VRS:	«MPB»	«MPH»	«MPD»	«MPC»
	Contained in 08VRS:	«MPB»	«MPH»	«MPD»	«MPC»
	Supported by supply unit:	«-»			

The drive provides a function for monitoring travel range limit switches (external hardware limit switches).



This monitor has to be activated and parameterized via "P-0-0090, Travel range limit parameter".

When the error F6044 occurs, the axis is shut down with velocity command value reset.

Cause	Remedy
Travel range limit switch situated in negative direction (see Project Planning Manual for motor) was activated because axis is outside of travel range that was defined by means of travel range limit switches.	<ol style="list-style-type: none"> 1. Clear error (reset button or error clearing command) and switch power on. 2. Set drive enable and preset command value that leads back to the allowed travel range.
Incorrect parameterization of digital inputs and outputs on control section.	Check configuration of digital inputs/outputs and correct it, if necessary.
Travel range limit switch or cable is defective or incorrectly wired.	Check function and wiring of travel range limit switch.
Control section or digital inputs on control section defective.	Replace control section or entire drive controller.



Only Rexroth service engineers or especially trained users are allowed to replace the control section. The replacement of the entire drive controller is described in the Project Planning Manual for the power section.

See also Functional Description of firmware:

- " Position Limitation/Travel Range Limit Switch"
- " Digital Inputs/Outputs".

F6044 - Attributes Display: F6044
 Ident N°: F6044

8.4.12 F6140 CCD slave error (emergency halt)

Allocation	Contained in 02VRS:	«-»	«-»	«-»	
	Contained in 03VRS:	«-»	«-»	«-»	
	Contained in 04VRS:	«-»	«MPH»	«-»	
	Contained in 05VRS:	«-»	«MPH»	«-»	
	Contained in 06VRS:	«-»	«-»	«-»	«MPC»
	Contained in 07VRS:	«-»	«-»	«-»	«MPC»
	Contained in 08VRS:	«-»	«-»	«-»	«MPC»
	Supported by supply unit:	«-»			

Error Messages

Cause	Remedy
"Error reaction active" has been set in "P-0-1600, CCD: configuration" and an F6 or F7 error occurred in a slave; CCD master reacts with emergency halt (velocity command value reset).	Localize faulty slave and remove cause of error for this slave.

See also Functional Description of firmware " Cross Communication (CCD)".

F6140 - Attributes **Display:** F6140
Ident N°: F6140

8.5 Interface Errors (F4xxx)

8.5.1 Behavior in Case of Interface Errors

The user can influence the behavior of the drive in case of interface errors by means of the parameterization of "P-0-0119, Best possible deceleration" (see Functional Description "Error Reaction").



As of MPx04, an MLD error reaction is possible (see P-0-0117).

At the end of the error reaction, the drive goes torque-free.

Commissioning Steps

The drive can only be put into operation again when:

1. The error reaction has been completed, i.e. the drive has stopped (v=0!).
2. The error message was cleared by the error clearing command (cf. "S-0-0099, C0500 Reset class 1 diagnostics").
3. The cause of the error was removed.
4. The drive is in the operating mode again and power was switched on ("Ab").
5. Drive enable was switched on again (0-1 edge).

8.5.2 F4001 Sync telegram failure

Allocation	Contained in 02VRS:	«MPB»	«MPH»	«MPD»	
	Contained in 03VRS:	«MPB»	«MPH»	«MPD»	
	Contained in 04VRS:	«MPB»	«MPH»	«MPD»	
	Contained in 05VRS:	«MPB»	«MPH»	«MPD»	
	Contained in 06VRS:	«MPB»	«MPH»	«MPD»	«MPC»
	Contained in 07VRS:	«MPB»	«MPH»	«MPD»	«MPC»
	Contained in 08VRS:	«MPB»	«MPH»	«MPD»	«MPC»
	Supported by supply unit:	«-»			

Master Communication SERCOS II

The master synchronization telegram (MST) was not received in the drive in two successive SERCOS cycles.

Cause	Remedy
Disturbance in fiber optic transmission line	Check all fiber optic cable connections in SERCOS ring and replace them, if necessary
Attenuation of light signals too high	Measure attenuation of fiber optic cable again (if necessary, increase transmission power via P-0-4027). Maximum attenuation between T _x and R _x mustn't exceed 12.5 dB!

Error Messages

Cause	Remedy
Different SERCOS cycle times in master and slave	Check SERCOS cycle times in master and slave and adjust them, if necessary
Disturbance in SERCOS interface (general)	Replace control section or entire drive

Master Communication SERCOS III The master synchronization telegram (MST) was not received in the drive in several successive SERCOS cycles. The number of allowed losses is set in S-0-1003.

Cause	Remedy
Different SERCOS cycle times in master and slave	Check SERCOS cycle times in master and slave and adjust them, if necessary
Disturbance in SERCOS interface (general)	Replace control section or entire drive

Master Communication CANopen The synchronization telegram was not received in the drive in two successive cycles.

Cause	Remedy
Sync master does not transmit Sync telegram	Check whether a bus node was configured as Sync master. Check Sync master to see whether it is in an error state
CAN bus interrupted	Check bus line
Disturbance in CANopen interface (general)	Replace control section or entire drive



Only Rexroth service engineers or especially trained users are allowed to replace the control section. The replacement of the entire drive controller is described in the Project Planning Manual for the power section.

See also Functional Description of firmware "Interface Errors and Diagnostic Possibilities"

F4001 - Attributes Display: F4001
 Ident N°: F4001

8.5.3 F4002 RTD telegram failure

Allocation	Contained in 02VRS:	«MPB»	«MPH»	«MPD»	
	Contained in 03VRS:	«MPB»	«MPH»	«MPD»	
	Contained in 04VRS:	«MPB»	«MPH»	«MPD»	
	Contained in 05VRS:	«MPB»	«MPH»	«MPD»	
	Contained in 06VRS:	«MPB»	«MPH»	«MPD»	«MPC»
	Contained in 07VRS:	«MPB»	«MPH»	«MPD»	«MPC»
	Contained in 08VRS:	«MPB»	«MPH»	«MPD»	«MPC»
	Supported by supply unit:	«-»			

Master Communication SERCOS II The master data telegram (MDT) was not received in the drive in two successive SERCOS or field bus cycles. The drive falls back to communication phase 0.

Error Messages

Cause	Remedy
Bus master does not send any more cyclic telegrams to drive. These, however, are expected in communication phase 4	Switch master on and start cyclic communication; see manual for control unit
Fiber optic cable bus: Disturbance in fiber optic transmission line	Check all fiber optic cable connections in SERCOS ring
Fiber optic cable bus: Input power of light signals too low. Light power to be measured at receiver (with test mode: continuous light) must be between -20 dBm (10 µW) and -5 dBm (320 µW)	Adjust transmission power or check attenuation of fiber optic cable. Maximum attenuation between T _x and R _x may not exceed 12.5 dB
Different transmission times of master data telegrams in master and slave	Synchronize transmission times of master data telegrams in master and slave
Disturbance in SERCOS interface (general)	Replace control section or entire drive controller

Master Communication SERCOS III A consumer connection violates the selected monitoring criterion.

Cause	Remedy
Synchronous monitoring has been preset for a connection and NewData bit of connection does not toggle in preset cycle	Producer of connection (can be bus master or another slave) does not work correctly
Too many telegrams fail due to disturbances	Check bus line and connector

Master Communication CANopen The real-time data telegram (RDT) was not received in the drive in two successive field bus cycles.

Cause	Remedy
PDO master does not send any more cyclic telegrams to drive	Switch master on and start cyclic communication; see manual for control unit
Bus line disturbed	Check bus line and connector
Disturbance in CANopen interface (general)	Replace control section or entire drive controller

Master Communication EtherCAT In status "Operational" (OP), the (command value) telegram was not received in the drive in two successive bus cycles.



In status "Operational" (OP), but **without** drive enable, the drive generates warning E4005.

Cause	Remedy
Incorrect timing settings	Check settings in master
Incorrect settings of "distributed clocks"	Check settings in master
Stop of cyclic telegrams in master while drive still is in AF	Remove drive enable before cyclic telegrams are stopped
Telegrams fail due to disturbances	Check bus line and connector



Only Rexroth service engineers or especially trained users are allowed to replace the control section. The replacement of the entire drive controller is described in the Project Planning Manual for the power section.

See also Functional Description of firmware "Interface Errors and Diagnostic Possibilities"

F4002 - Attributes **Display:** F4002
 Ident N°: F4002

8.5.4 F4003 Invalid communication phase shutdown

Allocation	Contained in 02VRS:	«MPB»	«MPH»	«MPD»	
	Contained in 03VRS:	«MPB»	«MPH»	«MPD»	
	Contained in 04VRS:	«MPB»	«MPH»	«MPD»	
	Contained in 05VRS:	«MPB»	«MPH»	«MPD»	
	Contained in 06VRS:	«MPB»	«MPH»	«MPD»	«MPC»
	Contained in 07VRS:	«MPB»	«MPH»	«MPD»	«MPC»
	Contained in 08VRS:	«MPB»	«MPH»	«MPD»	«MPC»
	Supported by supply unit:	«-»			

An invalid communication phase (phase > 4) was set by the SERCOS master module.

Cause	Remedy
Error in SERCOS master module of control unit	Error can only be corrected after consultation with control unit manufacturer

See also Functional Description of firmware " Interface Errors and Diagnostic Possibilities".

F4003 - Attributes **Display:** F4003
 Ident N°: F4003

8.5.5 F4004 Error during phase progression

Allocation	Contained in 02VRS:	«MPB»	«MPH»	«MPD»	
	Contained in 03VRS:	«MPB»	«MPH»	«MPD»	
	Contained in 04VRS:	«MPB»	«MPH»	«MPD»	
	Contained in 05VRS:	«MPB»	«MPH»	«MPD»	
	Contained in 06VRS:	«MPB»	«MPH»	«MPD»	«MPC»
	Contained in 07VRS:	«MPB»	«MPH»	«MPD»	«MPC»
	Contained in 08VRS:	«MPB»	«MPH»	«MPD»	«MPC»
	Supported by supply unit:	«-»			

The compulsory order was not followed during the phase progression.

Cause	Remedy
Error in SERCOS master module of control unit	Error can only be corrected after consultation with control unit manufacturer.

See also Functional Description of firmware "Interface Errors and Diagnostic Possibilities".

F4004 - Attributes **Display:** F4004
 Ident N°: F4004

8.5.6 F4005 Error during phase regression

Allocation	Contained in 02VRS:	«MPB»	«MPH»	«MPD»	
	Contained in 03VRS:	«MPB»	«MPH»	«MPD»	
	Contained in 04VRS:	«MPB»	«MPH»	«MPD»	
	Contained in 05VRS:	«MPB»	«MPH»	«MPD»	
	Contained in 06VRS:	«MPB»	«MPH»	«MPD»	«MPC»
	Contained in 07VRS:	«MPB»	«MPH»	«MPD»	«MPC»
	Contained in 08VRS:	«MPB»	«MPH»	«MPD»	«MPC»
	Supported by supply unit:	«-»			

Error Messages

When regressing from a communication phase the drive wasn't switched to communication phase 0.

Cause	Remedy
Error in SERCOS master module of control unit	Error can only be corrected after consultation with control unit manufacturer.

See also Functional Description of firmware "Interface Errors and Diagnostic Possibilities".

F4005 - Attributes Display: F4005
 Ident N°: F4005

8.5.7 F4006 Phase switching without ready signal

Allocation	Contained in 02VRS:	«MPB»	«MPH»	«MPD»	
	Contained in 03VRS:	«MPB»	«MPH»	«MPD»	
	Contained in 04VRS:	«MPB»	«MPH»	«MPD»	
	Contained in 05VRS:	«MPB»	«MPH»	«MPD»	
	Contained in 06VRS:	«MPB»	«MPH»	«MPD»	«MPC»
	Contained in 07VRS:	«MPB»	«MPH»	«MPD»	«MPC»
	Contained in 08VRS:	«MPB»	«MPH»	«MPD»	«MPC»
	Supported by supply unit:	«-»			

The SERCOS master tried to carry out a phase switch without waiting for the ready signal from the drive.

Cause	Remedy
Error in SERCOS master module of control unit	Error can only be corrected after consultation with control unit manufacturer.

See also Functional Description of firmware "Interface Errors and Diagnostic Possibilities".

F4006 - Attributes Display: F4006
 Ident N°: F4006

8.5.8 F4009 Bus failure

Allocation	Contained in 02VRS:	«MPB»	«MPH»	«MPD»	
	Contained in 03VRS:	«MPB»	«MPH»	«MPD»	
	Contained in 04VRS:	«MPB»	«MPH»	«MPD»	
	Contained in 05VRS:	«MPB»	«MPH»	«MPD»	
	Contained in 06VRS:	«MPB»	«MPH»	«MPD»	«MPC»
	Contained in 07VRS:	«MPB»	«MPH»	«MPD»	«MPC»
	Contained in 08VRS:	«MPB»	«MPH»	«MPD»	«MPC»
	Supported by supply unit:	«-»			

The cyclic communication via the master communication interface failed after the master communication interface had been initialized and commissioned.

The drive generates this error in the following cases:

- Within the monitoring time stored in P-0-4075, there hasn't any telegram with command values or heartbeat been received.
- or -
- The control unit was switched to "Stop" and the drive is with torque.
- or -
- The control unit took the drive out of the master communication group and the drive is with torque.

Error Messages



F4009 can be suppressed via P-0-4088 (bit 2,1="00"); in this case, E4005 is generated.

⚠ DANGER

Dangerous movements! Danger to life, risk of injury, serious injury or property damage by automatic restart after bus failure!

In the case of bus failure (message "F4009" or "E4005"), an error reaction must be carried out in the control unit, too, to prevent automatic restart after the bus has been reestablished. This means that the bits "Drive Halt", "drive enable" and "drive ON" (e.g. bits 13, 14 and 15 in parameter "P-0-4077, Field bus: Control word") should be reset in the control unit in the case of bus failure.

Causes and remedies of the triggering of the monitoring time stored in P-0-4075:

EtherNet/IP Only Class1 connections are monitored which means that, within the watchdog time, there haven't any new output data been received from the master.

Cause	Remedy
Master does not exchange any cyclic output data	Check master status
Ethernet connection aborted	Check Ethernet cable and, if necessary, switch
EMC problems at transmission line	Check shielding and routing
Network load too high	Switch off unnecessary Ethernet communication; if necessary, establish separate network for EtherNet/IP

DeviceNet Only the "Implicite Message" is monitored which means that, within the watchdog time, there haven't any new output data been received from the master.

Cause	Remedy
Master does not exchange any cyclic output data	Check master status
Bus connection interrupted	Check cable and interface
EMC problems at transmission line	Check shielding and routing
Bus load too high	Check communication settings (or communication load) ("InterScan Delay" setting at DeviceNet master)
Faulty bus terminator	Check whether bus terminating resistors have been installed at most distant bus nodes

CANopen According to the kind of node monitoring which has been set, the "Node Guarding request" (cyclic node monitoring) or the "heartbeat telegram" is monitored.

Cause	Remedy
Master does not transmit any node monitoring telegram	Check master status
Bus connection interrupted	Check cable and interface
EMC problems at transmission line	Check shielding and routing

8.5.10 F4012 Incorrect I/O length

Allocation	Contained in 02VRS:	«MPB»	«MPH»	«MPD»	
	Contained in 03VRS:	«MPB»	«MPH»	«MPD»	
	Contained in 04VRS:	«MPB»	«MPH»	«MPD»	
	Contained in 05VRS:	«MPB»	«MPH»	«MPD»	
	Contained in 06VRS:	«MPB»	«MPH»	«MPD»	«MPC»
	Contained in 07VRS:	«MPB»	«MPH»	«MPD»	«MPC»
	Contained in 08VRS:	«MPB»	«MPH»	«MPD»	«MPC»
	Supported by supply unit:	«-»			

The master tries to establish communication with an I/O length that does not correspond to the I/O length parameterized in the drive.

Cause	Remedy
Different length for input data or output data than drive expects in "P-0-4071, Field bus: length of cyclic command value data channel" and "P-0-4082, Field bus: length of cyclic actual value data channel" was configured in master	<ul style="list-style-type: none"> Check parameter set in drive Adjust master configuration
CCD system mode: In master communication master, different length for cyclic CCD data ("P-0-1621, CCD: Configuration list master communication cmd values" and "P-0-1622, CCD: Configuration list master communication actual values") than drive expects for CCD slaves was configured.	Take cyclic CCD data between master communication master and CCD slaves (correctly) into account
CCD system mode: (Virtual) field bus control word / field bus status word for CCD slaves not (or not correctly) taken into account	Take (virtual) field bus control word / field bus status word for CCD slaves into account (or correctly into account) (see also Functional Description of firmware "CCD System Mode".

F4012 - Attributes **Display:** F4012
 Ident N°: F4012

8.5.11 F4016 PLC double real-time channel failure

Allocation	Contained in 02VRS:	«-»	«-»	«-»	
	Contained in 03VRS:	«MPB»	«MPH»	«-»	
	Contained in 04VRS:	«MPB»	«MPH»	«-»	
	Contained in 05VRS:	«MPB»	«MPH»	«-»	
	Contained in 06VRS:	«MPB»	«MPH»	«-»	«MPC»
	Contained in 07VRS:	«MPB»	«MPH»	«-»	«MPC»
	Contained in 08VRS:	«MPB»	«MPH»	«-»	«MPC»
	Supported by supply unit:	«-»			

Writing of the "RtcW" variable of the integrated PLC to the corresponding parameters failed twice in succession / didn't take place in time.

Cause	Remedy
Function block "MX_SynchronControl" is used: Interval time of RTC task (task that uses real-time channel) is too short. Processing task code takes more time than one interval time.	Increase interval time of RTC task
Function block "MX_SynchronControl" is not used: At time of controlled transmission of "RtcW" variable, program code of RTC task hadn't yet been processed.	Increase interval time of RTC task - or - increase value at input "CmdDelay" of function block "MX_SynchronControl".

See also:

Error Messages

- Rexroth IndraMotion MLD, Application Manual "Real-Time Channel"
- Rexroth IndraMotion MLD, Library Description "MX_SynchronControl"

F4016 - Attributes Display: F4016
 Ident N°: F4016

8.5.12 F4017 S-III: Incorrect sequence during phase switch

Allocation	Contained in 02VRS:	«-»	«-»	«-»	
	Contained in 03VRS:	«-»	«-»	«-»	
	Contained in 04VRS:	«MPB»	«MPH»	«MPD»	
	Contained in 05VRS:	«MPB»	«MPH»	«MPD»	
	Contained in 06VRS:	«MPB»	«MPH»	«MPD»	«MPC»
	Contained in 07VRS:	«MPB»	«MPH»	«MPD»	«MPC»
	Contained in 08VRS:	«MPB»	«MPH»	«MPD»	«MPC»
	Supported by supply unit:	«-»			

Error in SERCOS-III master module of the control unit; the SERCOS-III master tried to make a phase switch, the drive detected that the sequence of this phase switch was incorrect.

Cause	Remedy
Timeout occurred in drive during phase switch (individual switching periods took too long) - or - Master changed phase without prior notice (new phase in MST without CPS bit set) - or - Drive was switched on while SERCOS III already was in higher phase	Error can only be corrected after consultation with control unit manufacturer

F4017 - Attributes Display: F4017
 Ident N°: F4017

8.5.13 F4034 Emergency-Stop activated

Allocation	Contained in 02VRS:	«MPB»	«MPH»	«MPD»	
	Contained in 03VRS:	«MPB»	«MPH»	«MPD»	
	Contained in 04VRS:	«MPB»	«MPH»	«MPD»	
	Contained in 05VRS:	«MPB»	«MPH»	«MPD»	
	Contained in 06VRS:	«MPB»	«MPH»	«MPD»	«MPC»
	Contained in 07VRS:	«MPB»	«MPH»	«MPD»	«MPC»
	Contained in 08VRS:	«MPB»	«MPH»	«MPD»	«MPC»
	Supported by supply unit:	«-»			

The drive provides a function for monitoring an E-Stop input (connection of an external hardware switch).

IndraDrive Mi: If "IndraDrive Mi" is used and the E-stop input is connected to the "KCU" electronic control system and parameter "P-0-0223, E-Stop input" is assigned to none of the digital inputs, the E-stop input of the "KCU" is monitored.



This monitor has to be activated and parameterized via "P-0-0008, Activation E-Stop function".

The axis is shut down as parameterized in "P-0-0119, Best possible deceleration".

The error can only be cleared, when the selection of E-Stop is removed or the evaluation of E-Stop was switched off.

Cause	Remedy
E-Stop input was controlled (0 V at digital input)	Remove failure that caused E-Stop to be triggered and clear error (reset key or error clearing command). Afterwards switch power on again and clarify cause of triggering of E-Stop
Incorrect parameterization of digital inputs and outputs on control section	Check configuration of digital inputs/outputs on control section and correct it, if necessary
E-Stop switch or cable connection defective or incorrectly wired	Check function and wiring of E-Stop switch
Control section or digital inputs on control section defective	Replace control section or entire drive controller



Only Rexroth service engineers or especially trained users are allowed to replace the control section. The replacement of the entire drive controller is described in the Project Planning Manual for the power section.

See also Functional Description of firmware:

- "E-Stop Function"
- "Digital Inputs/Outputs"
- "Best Possible Deceleration"

F4034 - Attributes Display: F4034
 Ident N°: F4034

8.5.14 F4140 CCD communication error

Allocation	Contained in 02VRS:	«-»	«-»	«-»	
	Contained in 03VRS:	«-»	«-»	«-»	
	Contained in 04VRS:	«-»	«MPH»	«-»	
	Contained in 05VRS:	«-»	«MPH»	«-»	
	Contained in 06VRS:	«-»	«-»	«-»	«MPC»
	Contained in 07VRS:	«-»	«-»	«-»	«MPC»
	Contained in 08VRS:	«-»	«-»	«-»	«MPC»
	Supported by supply unit:	«-»			

Cause	Remedy
CCD master detected double telegram failure of cyclic telegrams -or- "Error reaction active" has been set in "P-0-1600, CCD: configuration" and slave has signaled communication error.	Remove error in transmission line.



The CCD master is decelerated as set in "P-0-0119, Best possible deceleration".

See also Functional Description of firmware " Cross Communication (CCD)".

F4140 - Attributes Display: F4140
 Ident N°: F4140

Error Messages

8.6 Non-Fatal Safety Technology Errors (F3xxx)

8.6.1 Behavior in Case of Non-Fatal Safety Technology Errors

Non-fatal safety technology errors are errors which still allow carrying out a freely definable, variable error reaction.

Via the setting in "P-0-0119, Best possible deceleration", the user can define the **behavior of the drive** taking place when non-fatal safety technology errors occur.

Behavior When Using the Optional Safety Technology Module "S1" or "S2"

The drive automatically switches to safety related standstill or "Safe stop 1" (S2) and the output stage is switched off via two channels.

As soon as the axis has stopped, the axis signals safety; i.e., "safety technology status output controller" in "P-0-3214, Safety technology status word, channel 1" was set or the diagnosis input/output EA10n (channel 2) was set depending on the parameterization in "P-0-3210, Safety technology configuration".



An NC-controlled stopping process activated via "P-0-0117, Activation of control unit reaction on error" or an error reaction set via "P-0-0119, Best possible deceleration" is only possible for the duration entered in "P-0-3220, Tolerance time transition from normal operation" or "P-0-3225, Tolerance time transition from safe operation"! In case of timeout, the error "F7050 Time for stopping process exceeded" is generated.

At the end of the error reaction, the drive goes torque-free.

Commissioning Steps

Therefore, the drive can only be put into operation again when:

1. The error reaction has been completed, i.e. the drive has stopped (velocity = 0!).
2. The error message was cleared by the error clearing command (cf. "S-0-0099, C0500 Reset class 1 diagnostics").
3. The cause of the error was removed.
4. The drive is in the operating mode again and power was switched on ("Ab").
5. Drive enable was switched on again (0-1 edge).



In case non-fatal safety technology errors are occurring repeatedly, contact our service department as operating the drive then is no longer allowed.

8.6.2 F3111 Refer. missing when selecting safety related end pos.

Allocation	Contained in 02VRS:	«MPB»	«MPH»	«MPD»	
	Contained in 03VRS:	«MPB»	«MPH»	«MPD»	
	Contained in 04VRS:	«-»	«-»	«-»	
	Contained in 05VRS:	«-»	«-»	«-»	
	Contained in 06VRS:	«-»	«-»	«-»	«-»
	Contained in 07VRS:	«-»	«-»	«-»	«-»
	Contained in 08VRS:	«-»	«-»	«-»	«-»
	Supported by supply unit:	«-»			

The drive is shut down according to the setting in "P-0-0119, Best possible deceleration".

The drive automatically switches to safety related standstill or "Safe stop 1" (S2) and the output stage is switched off via two channels.

As soon as the axis has stopped, the safety door can be opened.

Error Messages

Cause	Remedy
The acceleration threshold parameterized in parameter "P-0-3245, Safe deceleration/acceleration ramp 1" was exceeded	Start command "S-0-0099, C0500 Reset class 1 diagnostics" in order to clear error and then set drive enable again. If necessary, increase value for parameter "P-0-3245, Safe deceleration/acceleration ramp 1"

F3111 - Attributes Display: F3111
 Ident N°: F3111

8.6.3 F3112 Safe reference missing

Allocation	Contained in 02VRS:	«MPB»	«MPH»	«MPD»	
	Contained in 03VRS:	«MPB»	«MPH»	«MPD»	
	Contained in 04VRS:	«MPB»	«MPH»	«MPD»	
	Contained in 05VRS:	«MPB»	«MPH»	«MPD»	
	Contained in 06VRS:	«MPB»	«MPH»	«MPD»	«MPC»
	Contained in 07VRS:	«MPB»	«MPH»	«MPD»	«MPC»
	Contained in 08VRS:	«MPB»	«MPH»	«MPD»	«MPC»
	Supported by supply unit:	«-»			

Up to MPx06: It was impossible to carry out the safety function "safety related limited absolute position" / "safety related limited absolute end position".

As of MPx07: It was impossible to carry out the safety function "Safely-monitored position" / "Safely-limited position".

Error Messages

Cause	Remedy
<p>Up to MPx06:</p> <p>Monitoring of safety related limited absolute end position has been configured ("P-0-3239, Configuration of global safety technology functions"); prerequisite of channel 2 having been homed is missing and drive is in special mode.</p> <p>- or -</p> <p>Monitoring of safety related limited absolute end position has been configured ("P-0-3239, Configuration of global safety technology functions"); prerequisite of channel 2 having been homed is missing and warning E3107 had been present for 15 minutes in normal operation.</p> <p>- or -</p> <p>Safety function "safety related limited absolute position" was selected and prerequisite of channel 2 having been homed is missing</p> <p>Note: Status of safe reference can be seen in "P-0-3238, Extended safety technology status".</p>	<ol style="list-style-type: none"> 1. Undo selection. 2. Start command "S-0-0099, C0500 Reset class 1 diagnostics", in order to clear error. 3. Set drive enable 4. a: For absolute measuring systems: Execute "P-0-3228, C4000 Homing procedure command channel 2" in order to establish "safety related reference" on channel 2. b: For all other measuring systems: Execute "S-0-0148, C0600 Drive-controlled homing procedure command" (C4000 for establishing safety related reference of channel 2 is integrated).
<p>As of MPx07:</p> <p>Monitoring of safely-limited position has been configured ("P-0-3239, Configuration of global safety technology functions"); prerequisite of channel 2 having been homed is missing and drive is in special mode.</p> <p>- or -</p> <p>Monitoring of safely-limited position has been configured ("P-0-3239, Configuration of global safety technology functions"); prerequisite of channel 2 having been homed is missing and warning E3107 had been present for 15 minutes in normal operation.</p> <p>- or -</p> <p>Safety function "Safely-monitored position" was selected and prerequisite of channel 2 having been homed is missing</p> <p>Note: Status of safe reference can be seen in "P-0-3238, Extended safety technology status".</p>	



When using the optional module "safety technology I/O" (S1) (up to MPx06) or "Safe Motion" (S2) (as of MPx07), you can, in addition to the error message, obtain detailed information with regard to the cause of the error or the error location. For this purpose, evaluate parameter "P-0-3219, Diagnostic safety technology message".

Up to MPx06: See "Extended Diagnosis (P-0-3219)".

As of MPx07: See "Extended Diagnosis (P-0-3219) as of MPx07".

Description of error reaction: "Behavior in Case of Non-Fatal Safety Technology Errors"

See documentation "Integrated Safety Technology", chapter "Safe Homing Procedure"

F3112 - Attributes **Display:** F3112
 Ident N°: F3112

8.6.4 F3115 Brake check time interval exceeded

Allocation	Contained in 02VRS:	«-»	«-»	«-»	
	Contained in 03VRS:	«MPB»	«MPH»	«MPD»	
	Contained in 04VRS:	«MPB»	«MPH»	«MPD»	
	Contained in 05VRS:	«MPB»	«MPH»	«MPD»	
	Contained in 06VRS:	«MPB»	«MPH»	«MPD»	«MPC»
	Contained in 07VRS:	«MPB»	«MPH»	«MPD»	«MPC»
	Contained in 08VRS:	«MPB»	«MPH»	«MPD»	«MPC»
	Supported by supply unit:	«-»			

When "time interval of holding brake check" was activated in "P-0-0525, Holding brake control word" or the function "safe braking and holding system" is used, the drive monitors the time which has passed since the last holding brake check.

The space of time set in "P-0-0550, Time interval holding system check" or "P-0-3302, SBS: Time interval brake check", within which the holding brake check has to be carried out again, was exceeded.

Error Reaction The drive reacts with the error reaction that has been set. The "status of holding brake check" is set to "0" in "P-0-0539, Holding brake status word".

If the "safe braking and holding system" is used as of MPx05, the "status of holding brake check" is additionally set to "0" in "P-0-3301, Redundant holding brake: Status word".

Cause	Remedy
Drive had been put into operation and drive enable was set; after 15 minutes, drive generates error F3115	Brake check (P-0-0541, C2100 Holding system check command) must be carried out within 15 minutes after drive was put into operation and drive enable was set
Time set in "P-0-0550, Time interval holding system check" or "P-0-3302, SBS: Time interval brake check" has elapsed since last brake check	Clear error; drive is operational again. Brake check must be carried out within 15 minutes (with drive enable) (P-0-0541, C2100 Holding system check command)
Repeated brake check is required due to defined errors in "safe braking and holding system". <ul style="list-style-type: none"> • Signal "HAT-Diagnose" is zero (control module "HAT" signals error or connection to control module has been interrupted) or • Signal "HAT-Diagnose" does not correspond to expectations from control status of redundant holding brake or • In case of error, redundant holding brake had to be applied with "actual velocity value > standstill" or • "C3000 Synchronize and store safety technology IDN" was executed 	Clear error; drive is operational again. Brake check must be carried out within 15 minutes (with drive enable) (P-0-0541, C2100 Holding system check command)

Error Messages



When using the optional module "safety technology I/O" (S1) (up to MPx06) or "Safe Motion" (S2) (as of MPx07), you can, in addition to the error message, obtain detailed information with regard to the cause of the error or the error location. For this purpose, evaluate parameter "P-0-3219, Diagnostic safety technology message".

Up to MPx06: See "Extended Diagnosis (P-0-3219)".

As of MPx07: See "Extended Diagnosis (P-0-3219) as of MPx07".

See also Functional Description of firmware "Motor Holding Brake"

See also documentation

- **Up to MPx06:** "Integrated Safety Technology"
- **As of MPx07:** "Integrated Safety Technology According to IEC61508"

F3115 - Attributes

Display: F3115
Ident N°: F3115

8.6.5 F3116 Nominal load torque of holding system exceeded

Allocation	Contained in 02VRS:	«-»	«-»	«-»	
	Contained in 03VRS:	«-»	«-»	«-»	
	Contained in 04VRS:	«MPB»	«MPH»	«MPD»	
	Contained in 05VRS:	«MPB»	«MPH»	«MPD»	
	Contained in 06VRS:	«MPB»	«MPH»	«MPD»	«MPC»
	Contained in 07VRS:	«MPB»	«MPH»	«MPD»	«MPC»
	Contained in 08VRS:	«MPB»	«MPH»	«MPD»	«MPC»
	Supported by supply unit:	«-»			

The current nominal load torque (P-0-0551) has exceeded the nominal load of the holding system (P-0-3303) by a factor of at least 1.3 (up to MPx07) or the factor parameterized in P-0-3316 (as of MPx08).

Cause	Remedy
The axis is overloaded	Avoid overload
Parameterization incorrect	Correct parameter setting <ul style="list-style-type: none"> • "P-0-0547, Nominal load of holding system" or • "P-0-3303, SBS: Nominal load" • "P-0-3316, SBS: Test torque factor motor holding brake " (as of MPx08)



When using the optional module "safety technology I/O" (S1) (up to MPx06) or "Safe Motion" (S2) (as of MPx07), you can, in addition to the error message, obtain detailed information with regard to the cause of the error or the error location. For this purpose, evaluate the parameter "P-0-3219, Diagnostic safety technology message".

Up to MPx06: See "Extended Diagnosis (P-0-3219)".

As of MPx07: See "Extended Diagnosis (P-0-3219) as of MPx07".

F3116 - Attributes

Display: F3116
Ident N°: F3116

8.6.6 F3117 Actual position values validation error

Allocation	Contained in 02VRS:	«MPB»	«MPH»	«MPD»	
	Contained in 03VRS:	«MPB»	«MPH»	«MPD»	
	Contained in 04VRS:	«MPB»	«MPH»	«MPD»	
	Contained in 05VRS:	«MPB»	«MPH»	«MPD»	
	Contained in 06VRS:	«MPB»	«MPH»	«MPD»	«MPC»
	Contained in 07VRS:	«MPB»	«MPH»	«MPD»	«MPC»
	Contained in 08VRS:	«MPB»	«MPH»	«MPD»	«MPC»
	Supported by supply unit:	«-»			

The two safety technology channels (channel 1 and channel 2) cyclically compare their actual position values crosswise for plausibility. The difference of the actual position values between channel 1 and channel 2 may not exceed an internal measuring-system-dependent threshold.

Error reaction The drive is shut down according to the setting in "P-0-0119, Best possible deceleration".

In "P-0-3213, Safety technology operating status", the status "safely homed" is removed.

Automatic switching to "safety related standstill" (up to MPx06) or "Safe stop 1" (as of MPx07) takes place and the output stage is switched off via two channels.

Cause	Remedy
<p>Only after safe homing</p> <p>Short circuit of home switch input of channel 2 with 24 V</p> <p>Note: For the configuration "homing procedure channel 2 via static signal", the signal at the homing input of channel 2 may only be 24 V when the axis is within "P-0-3231, Reference position for safe reference" +/- "P-0-3229, Tolerance window for safe homing procedure".</p>	<p>Check connection of homing input at optional module "safety technology I/O" (up to MPx06) or "Safe Motion" (as of MPx07).</p> <p>After troubleshooting, start command "S-0-0099, C0500 Reset class 1 diagnostics" in order to clear error and then set drive enable again.</p> <p>Then reestablish the safe reference (see also Documentation "Integrated safety technology", keyword "Safe homing procedure").</p>
<p>Other causes or subsequent errors</p>	<p>Read out the parameter "P-0-0192, Error memory of diagnostic numbers". If other errors occur before F3117, remedy these errors first and then the cause for the occurrence of F3117.</p> <p>Switch to "PM" or "P2" and start the command C0500 to clear the error. Then switch back to "bb" or "OM"; the actual position value comparison is reinitialized.</p> <p>If the error occurs again, please save all current parameter values using (S-0-0264, save RAM memory C2200 command) immediately after the error occurs. Please contact customer service to analyze the parameter backup.</p>



When using the optional module "safety technology I/O" (S1) (up to MPx06) or "Safe Motion" (S2) (as of MPx07), you can, in addition to the error message, obtain detailed information with regard to the cause of the error or the error location. For this purpose, evaluate the parameter "P-0-3219, Diagnostic safety technology message".

Up to MPx06: See "Extended Diagnosis (P-0-3219)".

As of MPx07: See "Extended Diagnosis (P-0-3219) as of MPx07".

Error Messages

F3117 - Attributes **Display:** F3117
Ident N°: F3117

8.6.7 F3122 SBS: System error

Allocation	Contained in 02VRS:	«-»	«-»	«-»	
	Contained in 03VRS:	«-»	«-»	«-»	
	Contained in 04VRS:	«-»	«-»	«-»	
	Contained in 05VRS:	«MPB»	«MPH»	«MPD»	
	Contained in 06VRS:	«MPB»	«MPH»	«MPD»	«MPC»
	Contained in 07VRS:	«MPB»	«MPH»	«MPD»	«MPC»
	Contained in 08VRS:	«MPB»	«MPH»	«MPD»	«MPC»
	Supported by supply unit:	«-»			

Monitoring functions of the safe braking and holding system have detected errors in the control or feedback circuit of the redundant holding brake.

Cause	Remedy
Brake server for controlling redundant holding brake is no longer active. Lifecounter brake server has not been incremented.	Replace hardware Replace firmware
No acknowledgment when releasing/applying redundant holding brake. Check takes place by means of feedback signal of control module.	Check wiring
Error during static check of control and feedback signal of control module	Check wiring Check control module
Requirements for releasing redundant holding brake have not been complied with. Output stage is not active	Replace hardware



When using the optional module "safety technology I/O" (S1) (up to MPx06) or "Safe Motion" (S2) (as of MPx07), you can, in addition to the error message, obtain detailed information with regard to the cause of the error or the error location. For this purpose, evaluate the parameter "P-0-3219, Diagnostic safety technology message".

Up to MPx06: See "Extended Diagnosis (P-0-3219)".

As of MPx07: See "Extended Diagnosis (P-0-3219) as of MPx07".

F3122 - Attributes **Display:** F3122
Ident N°: F3122

8.6.8 F3123 SBS: Brake check missing

Allocation	Contained in 02VRS:	«-»	«-»	«-»	
	Contained in 03VRS:	«-»	«-»	«-»	
	Contained in 04VRS:	«-»	«-»	«-»	
	Contained in 05VRS:	«MPB»	«MPH»	«MPD»	
	Contained in 06VRS:	«MPB»	«MPH»	«MPD»	«MPC»
	Contained in 07VRS:	«MPB»	«MPH»	«MPD»	«MPC»
	Contained in 08VRS:	«MPB»	«MPH»	«MPD»	«MPC»
	Supported by supply unit:	«-»			

Error Messages

Cause	Remedy
At selection of a safety technology operating status, a check has detected that states of holding brake monitoring of motor holding brake ((P-0-0539) and/or redundant holding brake (P-0-3301) have not been set to "carried out successfully"	Deselect safety technology operating status and execute "C2100 Brake check command"



When using the optional module "safety technology I/O" (S1) (up to MPx06) or "Safe Motion" (S2) (as of MPx07), you can, in addition to the error message, obtain detailed information with regard to the cause of the error or the error location. For this purpose, evaluate the parameter "P-0-3219, Diagnostic safety technology message".

Up to MPx06: See "Extended Diagnosis (P-0-3219)".

As of MPx07: See "Extended Diagnosis (P-0-3219) as of MPx07".

F3123 - Attributes **Display:** F3123
 Ident N°: F3123

8.6.9 F3130 Error when checking input signals

Allocation	Contained in 02VRS:	«MPB»	«MPH»	«MPD»	
	Contained in 03VRS:	«MPB»	«MPH»	«MPD»	
	Contained in 04VRS:	«MPB»	«MPH»	«MPD»	
	Contained in 05VRS:	«MPB»	«MPH»	«MPD»	
	Contained in 06VRS:	«MPB»	«MPH»	«MPD»	«MPC»
	Contained in 07VRS:	«MPB»	«MPH»	«MPD»	«MPC»
	Contained in 08VRS:	«MPB»	«MPH»	«MPD»	«MPC»
	Supported by supply unit:	«-»			

A validity check is run for the inputs for channel 1 and channel 2 of the safety technology so that several errors can be detected.

Up to MPx06 For the **optional module "starting lockout"**, the selection signals "AS_A" or "AS_B" and "ASn" are monitored for states that are not allowed.

For the **optional module "safety technology I/O"**, a check is run during dynamization to find out whether all input signals of safety function selection are zero.

As of MPx07 For the **optional module "Safe Torque Off"**, the selection signals "STO A" or "STO B" and "STO n" are monitored for states that are not allowed.

For the **optional module "Safe Motion"**, a check is run during dynamization to find out whether all input signals of safety function selection are zero.

Error Reaction The drive is shut down according to the setting in "P-0-0119, Best possible deceleration".

Automatic switching to "safety related standstill" (up to MPx06) or "Safe stop 1" (as of MPx07) takes place and the output stage is switched off via two channels.

Cause	Remedy
Error in wiring of input signals or contact error resp. cable break	Remove cause of error in wiring of inputs or replace switch. Then start command "S-0-0099, C0500 Reset class 1 diagnostics" in order to clear error and then set drive enable again.

Error Messages



When using the optional module "safety technology I/O" (S1) (up to MPx06) or "Safe Motion" (S2) (as of MPx07), you can, in addition to the error message, obtain detailed information with regard to the cause of the error or the error location. For this purpose, evaluate the parameter "P-0-3219, Diagnostic safety technology message".

Up to MPx06: See "Extended Diagnosis (P-0-3219)".

As of MPx07: See "Extended Diagnosis (P-0-3219) as of MPx07".

F3130 - Attributes
Display: F3130
Ident N°: F3130

8.6.10 F3131 Error when checking acknowledgment signal

Allocation	Contained in 02VRS:	«MPB»	«MPH»	«MPD»	
	Contained in 03VRS:	«MPB»	«MPH»	«MPD»	
	Contained in 04VRS:	«MPB»	«MPH»	«MPD»	
	Contained in 05VRS:	«MPB»	«MPH»	«MPD»	
	Contained in 06VRS:	«MPB»	«MPH»	«MPD»	«MPC»
	Contained in 07VRS:	«MPB»	«MPH»	«MPD»	«MPC»
	Contained in 08VRS:	«MPB»	«MPH»	«MPD»	«MPC»
	Supported by supply unit:	«-»			

The drive is shut down according to the setting in "P-0-0119, Best possible deceleration".

Automatic switching to "safety related standstill" (up to MPx06) or "Safe stop 1" (as of MPx07) takes place and the output stage is switched off via two channels.

As soon as the axis has stopped, the safety door can be opened.

When using optional module "starting lockout" (up to MPx06) or "Safe Torque Off" (as of MPx07):

Cause	Remedy
Channel 1 monitors status of acknowledgment relay. If normal condition of relay is detected in spite of activated "starting lockout" or "Safe Torque Off" function, or if operated condition of the relay is detected with starting lockout not active, error message F3131 is generated.	Reset module by switching control voltage off and on. If error occurs repeatedly, replace hardware
If error F3130 is generated in addition to error F3131 (see "P-0-0192, Error memory of diagnostic numbers"), an error in wiring of input signals or contact error resp. cable break might be present	See F3130

When using optional module "safety technology I/O" (up to MPx06) or "Safe Motion" (as of MPx07):

Error Messages

Cause	Remedy
During check of acknowledgment signal EA20, a static high level (short circuit with V+) or a static low level (short circuit to GND, cable break resp. loose / missing connection) was detected	Remove cause of error in wiring of acknowledgment signal EA20. Then start command "S-0-0099, C0500 Reset class 1 diagnostics" in order to clear error and then set drive enable again. Note: If only diagnostic safety technology slave signals F3131, this is a sign of missing connection of signal EA20 between master and slave
During check of acknowledgment signal EA20, a static high level was detected, <ul style="list-style-type: none"> because the safety technology for an axis in the security zone is not activated or an axis was parameterized with a single acknowledgement 	Remove cause of error in the parameterization of the security zone: <ul style="list-style-type: none"> activate security technology: "P-0-3207, parameterize safety technology password level" unequal to "0" parameterize zone acknowledgement: "P-0-3210, Safety technology configuration", bit 8="0"
Error during check of acknowledgment signal EA20, because two diagnostic acknowledgement masters were parameterized in the security zone	Remove cause of error in the parameterization of the security zone: Only one axis may be parameterized as a diagnostic acknowledgement master in the security zone ("P-0-3210, Safety technology configuration ", bit 2="1")
After a restart, the diagnostic acknowledgement master/ slave is in "OM" and a diagnostic acknowledgement slave/ master is in the booting phase	Start command "S-0-0099, C0500 Reset class 1 diagnostics" in order to clear error and then set drive enable again



When using the optional module "safety technology I/O" (S1) (up to MPx06) or "Safe Motion" (S2) (as of MPx07), you can, in addition to the error message, obtain detailed information with regard to the cause of the error or the error location. For this purpose, evaluate the parameter "P-0-3219, Diagnostic safety technology message".

Up to MPx06: See "Extended Diagnosis (P-0-3219)".

As of MPx07: See "Extended Diagnosis (P-0-3219) as of MPx07".

F3131 - Attributes **Display:** F3131
 Ident N°: F3131

8.6.11 F3132 Error when checking diagnostic output signal

Allocation	Contained in 02VRS:	«MPB»	«MPH»	«MPD»	
	Contained in 03VRS:	«MPB»	«MPH»	«MPD»	
	Contained in 04VRS:	«MPB»	«MPH»	«MPD»	
	Contained in 05VRS:	«MPB»	«MPH»	«MPD»	
	Contained in 06VRS:	«MPB»	«MPH»	«MPD»	«MPC»
	Contained in 07VRS:	«MPB»	«MPH»	«MPD»	«MPC»
	Contained in 08VRS:	«MPB»	«MPH»	«MPD»	«MPC»
	Supported by supply unit:	«-»			

With control of a safety door configured ("P-0-3210, Safety technology configuration", bit 2=1), the safety technology master for diagnosis and acknowledgement ("P-0-3210, Safety technology configuration", bit 1=1) checks whether....:

Error Messages

- ...a feedback is present at the diagnostic input of channel 1 (E10) ("P-9-3212, Safety technology control word, channel 1", bit 99) after transition to a safety function.
- ...feedback is no longer present at the diagnostic input of channel 1 (E10) ("P-9-3212, Safety technology control word, channel 1", bit 99) after transition to normal operation.

Error Reaction The drive is shut down according to the setting in "P-0-0119, Best possible deceleration". Automatic switching to "safety related standstill" (up to MPx06) or "Safe stop 1" (as of MPx07) takes place and the output stage is switched off via two channels.

Cause	Remedy
Error in wiring of diagnostic output / check input (A10, E10 or EA10n)	Remove error in wiring of diagnostic output / check input
Error in parameterization of diagnostic output / check input	Check bit 1=1 (control of a safety door) and bit 2=1 (safety technology master for diagnosis and acknowledgment) in parameter "P-0-3210, Safety technology configuration". Check status of A10 ("P-0-3214, Safety technology status word, channel 1", bit 0) and E10 ("P-0-3212, Safety technology control word, channel 1", bit 9) for corresponding digital inputs/outputs.
Internal relay on channel 2 defective	Replace control section or entire drive controller



Only Rexroth service engineers or especially trained users are allowed to replace the control section. The replacement of the entire drive controller is described in the Project Planning Manual for the power section.



When using the optional module "safety technology I/O" (S1) (up to MPx06) or "Safe Motion" (S2) (as of MPx07), you can, in addition to the error message, obtain detailed information with regard to the cause of the error or the error location. For this purpose, evaluate the parameter "P-0-3219, Diagnostic safety technology message".

Up to MPx06: See "Extended Diagnosis (P-0-3219)".

As of MPx07: See "Extended Diagnosis (P-0-3219) as of MPx07".

F3132 - Attributes

Display: F3132
Ident N°: F3132

8.6.12 F3133 Error when checking interrupting circuits

Allocation	Contained in 02VRS:	«MPB»	«MPH»	«MPD»	
	Contained in 03VRS:	«MPB»	«MPH»	«MPD»	
	Contained in 04VRS:	«MPB»	«MPH»	«MPD»	
	Contained in 05VRS:	«MPB»	«MPH»	«MPD»	
	Contained in 06VRS:	«MPB»	«MPH»	«MPD»	«MPC»
	Contained in 07VRS:	«MPB»	«MPH»	«MPD»	«MPC»
	Contained in 08VRS:	«MPB»	«MPH»	«MPD»	«MPC»
	Supported by supply unit:	«-»			

In order to lock the output stage in a safe way when the safety technology has detected an error, the correct functioning of the interrupting circuit is cyclically checked. This is done on the one hand during the actions "release output stage" and "lock output stage", on the other hand statically while the

Error Messages

output stage is being released or locked. The corresponding hardware realization ensures that this is possible without repercussion on the PWM control signals.

 When the safety technology has been activated, the error F3133 only occurs in normal operation. When a safety function is selected, the cause of the error causes the error "F8133 Error when checking interrupting circuit" to be triggered.

The drive is shut down according to the setting in "P-0-0119, Best possible deceleration". Automatic switching to "safety related standstill" (up to MPx06) or "Safe stop 1" (as of MPx07) takes place and the output stage is switched off via two channels.

 Safety is not acknowledged; i.e., "safety technology status output controller" in "P-0-3214, Safety technology status word, channel 1" was cleared/reset or the diagnostic input/output EA10n (channel 2) was set depending on the parameterization in "P-0-3210, Safety technology configuration".

Cause	Remedy
An error was detected during check of interrupting circuit	Then start command "S-0-0099, C0500 Reset class 1 diagnostics" in order to clear error and then set drive enable again. If error occurs repeatedly, replace control section or entire drive controller

 Only Rexroth service engineers or especially trained users are allowed to replace the control section. The replacement of the entire drive controller is described in the Project Planning Manual for the power section.

 When using the optional module "safety technology I/O" (S1) (up to MPx06) or "Safe Motion" (S2) (as of MPx07), you can, in addition to the error message, obtain detailed information with regard to the cause of the error or the error location. For this purpose, evaluate the parameter "P-0-3219, Diagnostic safety technology message".

Up to MPx06: See "Extended Diagnosis (P-0-3219)".

As of MPx07: See "Extended Diagnosis (P-0-3219) as of MPx07".

F3133 - Attributes **Display:** F3133
 Ident N°: F3133

8.6.13 F3134 Dynamization time interval incorrect

Allocation	Contained in 02VRS:	«MPB»	«MPH»	«MPD»	
	Contained in 03VRS:	«MPB»	«MPH»	«MPD»	
	Contained in 04VRS:	«MPB»	«MPH»	«MPD»	
	Contained in 05VRS:	«MPB»	«MPH»	«MPD»	
	Contained in 06VRS:	«MPB»	«MPH»	«MPD»	«MPC»
	Contained in 07VRS:	«MPB»	«MPH»	«MPD»	«MPC»
	Contained in 08VRS:	«MPB»	«MPH»	«MPD»	«MPC»
	Supported by supply unit:	«-»			

Error Messages

The signal shape of the "dynamization signal of safety function selection" is monitored.



Monitoring normally refers to the signals at the dynamization input EA30. If "separate dynamization" has been set in "P-0-3210, Safety technology configuration", the dynamization input for channel 1 is additionally monitored (see also "P-0-3212, Safety technology control word, channel 1").

Error Reaction The drive is shut down according to the setting in "P-0-0119, Best possible deceleration". Automatic switching to "safety related standstill" (up to MPx06) or "Safe stop 1" (as of MPx07) takes place and the output stage is switched off via two channels.

Cause	Remedy
Error in wiring of dynamization signal (e.g. short circuit with V+)	Check wiring of dynamization signal and remove error
Error in signal shape of dynamization signal in the case of external dynamization (see also "F3135 Dynamization pulse width incorrect")	Check and, if necessary, correct dynamization signal. Relevant parameters: <ul style="list-style-type: none"> "P-0-3223, Time interval for dynamization of safety function selection" (+20% tolerance) mustn't be exceeded "P-0-3224, Duration of dynamization pulse of safety function selection"
Parameterization of "P-0-3210, Safety technology configuration" not useful	In the case of internal dynamization, per safety zone configure one axis as master for dynamization (set bit 3 in "P-0-3210, Safety technology configuration").

After having removed the error, start the command "S-0-0099, C0500 Reset class 1 diagnostics" in order to clear the error and then set drive enable again.



If error message occurs repeatedly, safety technology firmware has to be replaced.

- or -

Control section (only by Rexroth service engineers or especially trained users) or entire drive controller has to be replaced. The replacement of the entire drive controller is described in the Project Planning Manual for the power section.



When using the optional module "safety technology I/O" (S1) (up to MPx06) or "Safe Motion" (S2) (as of MPx07), you can, in addition to the error message, obtain detailed information with regard to the cause of the error or the error location. For this purpose, evaluate the parameter "P-0-3219, Diagnostic safety technology message".

Up to MPx06: See "Extended Diagnosis (P-0-3219)".

As of MPx07: See "Extended Diagnosis (P-0-3219) as of MPx07".

F3134 - Attributes

Display: F3134
Ident N°: F3134

8.6.14 F3135 Dynamization pulse width incorrect

Allocation	Contained in 02VRS:	«MPB»	«MPH»	«MPD»	
	Contained in 03VRS:	«MPB»	«MPH»	«MPD»	
	Contained in 04VRS:	«MPB»	«MPH»	«MPD»	
	Contained in 05VRS:	«MPB»	«MPH»	«MPD»	
	Contained in 06VRS:	«MPB»	«MPH»	«MPD»	«MPC»
	Contained in 07VRS:	«MPB»	«MPH»	«MPD»	«MPC»
	Contained in 08VRS:	«MPB»	«MPH»	«MPD»	«MPC»
	Supported by supply unit:	«-»			

For "dynamization of safety function selection", a dynamic signal is applied to the selection elements, in order to detect errors in the wiring of the input signal / input signals. The signal shape of the dynamic signal / dynamic signals is monitored, too.

The monitoring refers to the signal at the input EA30 and in the case of separate dynamization ("P-0-3210, Safety technology configuration", bit7=1) additionally to the "dynamization signal channel 1" ("P-0-3212, Safety technology control word, channel 1", bit10).

The pulse width of the dynamization signal was detected to be too short or too long; the minimum pulse width is 30 ms, the maximum pulse width is determined via "P-0-3224, Duration of dynamization pulse of safety function selection" (plus a tolerance of 20 percent).

Error Reaction The drive is shut down according to the setting in "P-0-0119, Best possible deceleration". Automatic switching to "safety related standstill" (up to MPx06) or "Safe stop 1" (as of MPx07) takes place and the output stage is switched off via two channels.

Cause	Remedy
Error in wiring of dynamization signal EA30	Remove error in wiring of dynamization signal EA30 [e.g., short circuit with 0 V (GND), cable break, missing connection to master of dynamization]
In the case of separate dynamization ("P-0-3210, Safety technology configuration", bit7=1): Error in wiring of "dynamization input channel 1" ("P-0-3212, Safety technology control word, channel 1", bit10)	Remove error in wiring of dynamization signal [e.g., short circuit with 0 V (GND), cable break, missing connection to master of dynamization] - or - Missing or incorrect settings for transmission via master communication
In the case of internal dynamization ("P-0-3210, Safety technology configuration", bit7=0): Error in signal shape of dynamization signal	Check parameterization of <ul style="list-style-type: none"> "P-0-3210, Safety technology configuration" (only one drive may be selected as master for dynamization, all other drives must be declared slaves) "P-0-3223, Time interval for dynamization of safety function selection" and "P-0-3224, Duration of dynamization pulse of safety function selection" in involved slave axes have to be greater than or equal to values in master axis

Error Messages

Cause	Remedy
In the case of external dynamization: Error in signal shape of dynamization signal	<p>In the case of external dynamization, all drives that are to be dynamized have to be parameterized as "slave for dynamization of safety function selection" via "P-0-3210, Safety technology configuration". EA30 of respective drives have to be interconnected and connected to signal source.</p> <p>Dynamization signal is generated by external source and this source has to be connected to selection elements and dynamization signal EA30.</p> <p>Signal shape mustn't exceed parameter values "P-0-3223, Time interval for dynamization of safety function selection" and "P-0-3224, Duration of dynamization pulse of safety function selection".</p> <p>Signal monitoring takes place with retriggerable timers; i.e., dynamization may also take place in shorter intervals and with shorter pulse width (minimum 30 ms).</p>
In the case of separate dynamization for channel 1 and channel 2 ("P-0-3210, Safety technology configuration", bit7=1): Error in signal shape of dynamization signal EA30	<p>Channel 2: Interconnect EA30 of respective drives. Dynamize N/C contacts of selection elements with dynamization signal EA30.</p> <p>Channel 1: Dynamization signal for channel 1 is generated by external source. "Dynamization input channel 1" ("P-0-3212, Safety technology control word, channel 1", bit 10) of respective drives has to be interconnected and connected to signal source. Dynamize N/O contacts of selection elements with externally generated "dynamization signal channel 1".</p> <p>Signal shape mustn't exceed parameter values "P-0-3223, Time interval for dynamization of safety function selection" and "P-0-3224, Duration of dynamization pulse of safety function selection".</p> <p>Signal monitoring takes place with retriggerable timers; i.e., dynamization may also take place in shorter intervals and with shorter pulse width (minimum 30 ms).</p>

After having removed the cause, start the command "S-0-0099, C0500 Reset class 1 diagnostics" in order to clear the error and then set drive enable again.



If error message occurs repeatedly, safety technology firmware has to be replaced.

- or -

Control section (only by Rexroth service engineers or especially trained users) or entire drive controller has to be replaced. The replacement of the entire drive controller is described in the Project Planning Manual for the power section.

Error Messages

8.6.16 F3141 Selection validation error

Allocation	Contained in 02VRS:	«MPB»	«MPH»	«MPD»	
	Contained in 03VRS:	«MPB»	«MPH»	«MPD»	
	Contained in 04VRS:	«MPB»	«MPH»	«MPD»	
	Contained in 05VRS:	«MPB»	«MPH»	«MPD»	
	Contained in 06VRS:	«MPB»	«MPH»	«MPD»	«MPC»
	Contained in 07VRS:	«MPB»	«MPH»	«MPD»	«MPC»
	Contained in 08VRS:	«MPB»	«MPH»	«MPD»	«MPC»
	Supported by supply unit:	«-»			

The check carried out when selecting/deselecting safety functions has shown that the selection signals of channel 1 and channel 2 differed for a longer time than the tolerated duration preset by "P-0-3221, Max. tolerance time for different channel states".

The drive is shut down according to the setting in "P-0-0119, Best possible deceleration". Automatic switching to "safety related standstill" (up to MPx06) or "Safe stop 1" (as of MPx07) takes place and the output stage is switched off via two channels.

As soon as the axis has stopped, the safety door can be opened.

Cause	Remedy
Error in wiring of input signals or switch defective	Check switch elements and wiring of input signals
Different safety functions assigned to inputs of channel 1 and channel 2	Check configuration of inputs of channel 1 and channel 2
Parameterization of "P-0-3221, Max. tolerance time for different channel states" not useful	Change parameterization of "P-0-3221, Max. tolerance time for different channel states" (increase value)



When using the optional module "safety technology I/O" (S1) (up to MPx06) or "Safe Motion" (S2) (as of MPx07), you can, in addition to the error message, obtain detailed information with regard to the cause of the error or the error location. For this purpose, evaluate the parameter "P-0-3219, Diagnostic safety technology message".

Up to MPx06: See "Extended Diagnosis (P-0-3219)".

As of MPx07: See "Extended Diagnosis (P-0-3219) as of MPx07".

After having removed the cause, start the command "S-0-0099, C0500 Reset class 1 diagnostics" in order to clear the error and then set drive enable again.

F3141 - Attributes	Display:	F3141
	Ident N°:	F3141

8.6.17 F3142 Activation time of enabling control exceeded

Allocation	Contained in 02VRS:	«MPB»	«MPH»	«MPD»	
	Contained in 03VRS:	«MPB»	«MPH»	«MPD»	
	Contained in 04VRS:	«MPB»	«MPH»	«MPD»	
	Contained in 05VRS:	«MPB»	«MPH»	«MPD»	
	Contained in 06VRS:	«MPB»	«MPH»	«MPD»	«MPC»
	Contained in 07VRS:	«MPB»	«MPH»	«MPD»	«MPC»
	Contained in 08VRS:	«MPB»	«MPH»	«MPD»	«MPC»
	Supported by supply unit:	«-»			

The parameterized maximum time for the activation of the enabling control has been exceeded.

Error Messages

Error Reaction The drive is shut down according to the setting in "P-0-0119, Best possible deceleration". Automatic switching to "safety related standstill" (up to MPx06) or "Safe stop 1" (as of MPx07) takes place and the output stage is switched off via two channels.

Cause	Remedy
Enabling control was activated too long	Remove enabling signal before parameterized time is over; parameterizable activation times of enabling control: <ul style="list-style-type: none"> • "P-0-3222, Max. activation time of enabling control" or • "P-0-3246, Max. activation time of enabling control 1" (as of MPx05) • "P-0-3256, Max. activation time of enabling control 2" (as of MPx05) • "P-0-3266, Max. activation time of enabling control 3" (as of MPx05) • "P-0-3276, Max. activation time of enabling control 4" (as of MPx05) The currently valid parameter can be taken from P-0-3239.
Parameterization of maximum activation time of enabling control does not make sense	Check parameterization and change it, if necessary: <ul style="list-style-type: none"> • "P-0-3222, Max. activation time of enabling control" or • "P-0-3246, Max. activation time of enabling control 1" (as of MPx05) • "P-0-3256, Max. activation time of enabling control 2" (as of MPx05) • "P-0-3266, Max. activation time of enabling control 3" (as of MPx05) • "P-0-3276, Max. activation time of enabling control 4" (as of MPx05) The currently valid parameter can be taken from P-0-3239.
Enabling control is defective or incorrectly wired	Check and, if necessary, replace/correct enabling control and wiring



When using the optional module "safety technology I/O" (S1) (up to MPx06) or "Safe Motion" (S2) (as of MPx07), you can, in addition to the error message, obtain detailed information with regard to the cause of the error or the error location. For this purpose, evaluate the parameter "P-0-3219, Diagnostic safety technology message".

Up to MPx06: See "Extended Diagnosis (P-0-3219)".

As of MPx07: See "Extended Diagnosis (P-0-3219) as of MPx07".

After having removed the cause, start the command "S-0-0099, C0500 Reset class 1 diagnostics" in order to clear the error and then set drive enable again.

F3142 - Attributes

Display: F3142
Ident N°: F3142

Error Messages

8.6.18 F3143 Safety command for clearing errors incorrect

Allocation	Contained in 02VRS:	«MPB»	«MPH»	«MPD»	
	Contained in 03VRS:	«MPB»	«MPH»	«MPD»	
	Contained in 04VRS:	«MPB»	«MPH»	«MPD»	
	Contained in 05VRS:	«MPB»	«MPH»	«MPD»	
	Contained in 06VRS:	«MPB»	«MPH»	«MPD»	«MPC»
	Contained in 07VRS:	«MPB»	«MPH»	«MPD»	«MPC»
	Contained in 08VRS:	«MPB»	«MPH»	«MPD»	«MPC»
	Supported by supply unit:	«-»			

Via an internal command embedded in the call of "S-0-0099, C0500 Reset class 1 diagnostics", all errors of channel 2 are cleared. If a problem is detected during this procedure, the drive generates the error F3143.

Error Reaction The drive is shut down according to the setting in "P-0-0119, Best possible deceleration". Automatic switching to "safety related standstill" (up to MPx06) or "Safe stop 1" (as of MPx07) takes place and the output stage is switched off via two channels.

Cause	Remedy
If error message coincides with a firmware update, this indicates that firmware on channel 2 was not started; in this case, "P-0-3200, Safety technology firmware code" is without content. (This can be due to following reasons: Firmware of channel 2 incompatible with channel 1, checksum or hardware error on channel 2.)	Carry out firmware update again
Execution of internal command was aborted with timeout	Reset module by switching control voltage off and on. If error occurs repeatedly, replace control section or entire drive controller



Only Rexroth service engineers or especially trained users are allowed to replace the control section. The replacement of the entire drive controller is described in the Project Planning Manual for the power section.



When using the optional module "safety technology I/O" (S1) (up to MPx06) or "Safe Motion" (S2) (as of MPx07), you can, in addition to the error message, obtain detailed information with regard to the cause of the error or the error location. For this purpose, evaluate the parameter "P-0-3219, Diagnostic safety technology message".

Up to MPx06: See "Extended Diagnosis (P-0-3219)".

As of MPx07: See "Extended Diagnosis (P-0-3219) as of MPx07".

See also Functional Description of firmware "Firmware Release Update"

F3143 - Attributes

Display: F3143
Ident N°: F3143

8.6.19 F3144 Incorrect safety configuration

Allocation	Contained in 02VRS:	«-»	«-»	«-»	
	Contained in 03VRS:	«MPB»	«MPH»	«MPD»	
	Contained in 04VRS:	«MPB»	«MPH»	«MPD»	
	Contained in 05VRS:	«MPB»	«MPH»	«MPD»	
	Contained in 06VRS:	«MPB»	«MPH»	«MPD»	«MPC»
	Contained in 07VRS:	«MPB»	«MPH»	«MPD»	«MPC»
	Contained in 08VRS:	«MPB»	«MPH»	«MPD»	«MPC»
	Supported by supply unit:	«-»			

An error was detected in the configuration of safety technology.

Error Reaction The drive is shut down according to the setting in "P-0-0119, Best possible deceleration". Automatic switching to "safety related standstill" (up to MPx06) or "Safe stop 1" (as of MPx07) takes place and the output stage is switched off via two channels.

Cause	Remedy
Safety technology control signals (selection signals) were configured in "P-0-3211, Safety technology I/O configuration list, channel 2", but safety technology with PROFIsafe has not been configured or hardware requirements therefor are missing	For configuration "safety technology with PROFIsafe", only assignment of home switch and safety technology inputs 1 to 4 is allowed; for the other safety technology control signals it is not allowed to establish any functional connection; change parameter setting of "P-0-3211, Safety technology I/O configuration list, channel 2" accordingly
In "P-0-3211, Safety technology I/O configuration list, channel 2", safety technology control signals (selection signals) were assigned several times	In "P-0-3211, Safety technology I/O configuration list, channel 2", only assign safety technology control signals (selection signals) once
Safety technology inputs 1 to 4 were configured in "P-0-3211, Safety technology I/O configuration list, channel 2", but safety technology with PROFIsafe has not been configured or hardware requirements therefor are missing	Safety technology inputs 1 to 4 are only allowed in conjunction with configuration "safety technology with PROFIsafe"; change parameterization of "P-0-3211, Safety technology I/O configuration list, channel 2" accordingly
Two configurations were inadmissibly made at the same time for the axis: Master for diagnosis and acknowledgment ("P-2-3210, Safety technology configuration", bit 2) - and - "Deactivation of acknowledgment support at EA20", i.e. drive does not work in acknowledgment group ("P-0-3210, Safety technology configuration", bit 8)	One of both configurations must be undone
Safety function "Safely-limited position" was configured without safety function "Safe maximum speed"	Configure safety function "Safe maximum speed" (P-0-3239, P-0-3234)

After troubleshooting, start command "S-0-0099, C0500 Reset class 1 diagnostics" in order to clear error and then set drive enable again.



When using the optional module "safety technology I/O" (S1) (up to MPx06) or "Safe Motion" (S2) (as of MPx07), you can, in addition to the error message, obtain detailed information with regard to the cause of the error or the error location. For this purpose, evaluate the parameter "P-0-3219, Diagnostic safety technology message".

Up to MPx06: See "Extended Diagnosis (P-0-3219)".

As of MPx07: See "Extended Diagnosis (P-0-3219) as of MPx07".

Error Messages

F3144 - Attributes **Display:** F3144
Ident N°: F3144

8.6.20 F3145 Error when unlocking the safety door

Allocation	Contained in 02VRS:	«MPB»	«MPH»	«MPD»	
	Contained in 03VRS:	«MPB»	«MPH»	«MPD»	
	Contained in 04VRS:	«MPB»	«MPH»	«MPD»	
	Contained in 05VRS:	«MPB»	«MPH»	«MPD»	
	Contained in 06VRS:	«MPB»	«MPH»	«MPD»	«MPC»
	Contained in 07VRS:	«MPB»	«MPH»	«MPD»	«MPC»
	Contained in 08VRS:	«MPB»	«MPH»	«MPD»	«MPC»
	Supported by supply unit:	«-»			

When the special mode is deselected, a check is run to find out whether the control of the door locking device is inactive and the door is closed and locked.

Error Reaction The drive is shut down according to the setting in "P-0-0119, Best possible deceleration".

- or -

The axis already is in "safety related standstill" (up to MPx06) or "Safe stop 1" (as of MPx07) and the output stage is switched off via two channels.

Cause	Remedy
Error in mechanical system of safety door	Check mechanical system of safety door
Error in wiring of safety door or short circuit between EA10n, A10, E10 and 24 V	Check wiring of safety door
Hardware defect on control section or on optional safety technology module	Replace control section or entire drive controller



Only Rexroth service engineers or especially trained users are allowed to replace the control section. The replacement of the entire drive controller is described in the Project Planning Manual for the power section.



When using the optional module "safety technology I/O" (S1) (up to MPx06) or "Safe Motion" (S2) (as of MPx07), you can, in addition to the error message, obtain detailed information with regard to the cause of the error or the error location. For this purpose, evaluate the parameter "P-0-3219, Diagnostic safety technology message".

Up to MPx06: See "Extended Diagnosis (P-0-3219)".

As of MPx07: See "Extended Diagnosis (P-0-3219) as of MPx07".

F3145 - Attributes **Display:** F3145
Ident N°: F3145

8.6.21 F3146 System error channel 2

Allocation	Contained in 02VRS:	«MPB»	«MPH»	«MPD»	
	Contained in 03VRS:	«MPB»	«MPH»	«MPD»	
	Contained in 04VRS:	«MPB»	«MPH»	«MPD»	
	Contained in 05VRS:	«MPB»	«MPH»	«MPD»	
	Contained in 06VRS:	«MPB»	«MPH»	«MPD»	«MPC»
	Contained in 07VRS:	«MPB»	«MPH»	«MPD»	«MPC»
	Contained in 08VRS:	«MPB»	«MPH»	«MPD»	«MPC»
	Supported by supply unit:	«-»			

The drive is shut down according to the setting in "P-0-0119, Best possible deceleration". Automatic switching to "safety related standstill" (up to MPx06) or "Safe stop 1" (as of MPx07) takes place and the output stage is switched off via two channels.

In the case of a measuring system error, the safety door can only be opened via the command "P-0-3218, C3700 Manually unlocking the safety door".

Cause	Remedy
System error on channel 2	Reset module by switching control voltage off and on. Then start command "S-0-0099, C0500 Reset class 1 diagnostics" in order to clear error and then set drive enable again. If error occurs repeatedly, replace control section or entire drive controller
Failure of encoder signal	<ul style="list-style-type: none"> • Check cable to measuring system • Check shield connection • Check connection (ribbon cable) between optional safety technology module and encoder interface
No encoder signals	<ul style="list-style-type: none"> • Connection (ribbon cable) between optional safety technology module and encoder interface is missing • Check measuring system



Only Rexroth service engineers or especially trained users are allowed to replace the control section. The replacement of the entire drive controller is described in the Project Planning Manual for the power section.



When using the optional module "safety technology I/O" (S1) (up to MPx06) or "Safe Motion" (S2) (as of MPx07), you can, in addition to the error message, obtain detailed information with regard to the cause of the error or the error location. For this purpose, evaluate the parameter "P-0-3219, Diagnostic safety technology message".

Up to MPx06: See "Extended Diagnosis (P-0-3219)".

As of MPx07: See "Extended Diagnosis (P-0-3219) as of MPx07".

F3146 - Attributes

Display: F3146
Ident N°: F3146

Error Messages

8.6.22 F3147 System error channel 1

Allocation	Contained in 02VRS:	«MPB»	«MPH»	«MPD»	
	Contained in 03VRS:	«MPB»	«MPH»	«MPD»	
	Contained in 04VRS:	«MPB»	«MPH»	«MPD»	
	Contained in 05VRS:	«MPB»	«MPH»	«MPD»	
	Contained in 06VRS:	«MPB»	«MPH»	«MPD»	«MPC»
	Contained in 07VRS:	«MPB»	«MPH»	«MPD»	«MPC»
	Contained in 08VRS:	«MPB»	«MPH»	«MPD»	«MPC»
	Supported by supply unit:	«-»			

The operatability of safety monitoring functions is cyclically checked in normal operation.

The drive is shut down according to the setting in "P-0-0119, Best possible deceleration". Automatic switching to "safety related standstill" (up to MPx06) or "Safe stop 1" (as of MPx07) takes place and the output stage is switched off via two channels.

As soon as the axis has stopped, the safety door can be opened.

Cause	Remedy
Cyclic test of monitoring functions of safety technology channel 1 is faulty	Reset module by switching control voltage off and on. If error occurs repeatedly, replace firmware and/or hardware
You use a test firmware (to be recognized, among other things, by "P-0-3213, Safety technology operating status", bit 14). Test firmware was provided as an exception for applications without active safety technology; safety technology firmware test was not carried out for this firmware!	Replace firmware by test firmware with safety technology firmware test or official firmware (V-release) with which safety technology can always be used without restrictions.



Only Rexroth service engineers are allowed to replace options of the control section.

Only Rexroth service engineers or especially trained users are allowed to replace the control section. The replacement of the entire drive controller is described in the Project Planning Manual for the power section.



When using the optional module "safety technology I/O" (S1) (up to MPx06) or "Safe Motion" (S2) (as of MPx07), you can, in addition to the error message, obtain detailed information with regard to the cause of the error or the error location. For this purpose, evaluate the parameter "P-0-3219, Diagnostic safety technology message".

Up to MPx06: See "Extended Diagnosis (P-0-3219)".

As of MPx07: See "Extended Diagnosis (P-0-3219) as of MPx07".

F3147 - Attributes

Display: F3147
Ident N°: F3147

8.6.23 F3150 Safety command for system start incorrect

Allocation	Contained in 02VRS:	«MPB»	«MPH»	«MPD»	
	Contained in 03VRS:	«MPB»	«MPH»	«MPD»	
	Contained in 04VRS:	«MPB»	«MPH»	«MPD»	
	Contained in 05VRS:	«MPB»	«MPH»	«MPD»	
	Contained in 06VRS:	«MPB»	«MPH»	«MPD»	«MPC»
	Contained in 07VRS:	«MPB»	«MPH»	«MPD»	«MPC»
	Contained in 08VRS:	«MPB»	«MPH»	«MPD»	«MPC»
	Supported by supply unit:	«-»			

Channel 2 of the safety technology is switched from parameter mode to operating mode via an internal command. During the command, channel 2 carries out the necessary initialization steps.

Error Reaction The drive is shut down according to the setting in "P-0-0119, Best possible deceleration". Automatic switching to "safety related standstill" (up to MPx06) or "Safe stop 1" (as of MPx07) takes place and the output stage is switched off via two channels.

Cause	Remedy
Timeout in command processing	Start command "S-0-0099, C0500 Reset class 1 diagnostics" in order to clear error. ⇒ Reset optional safety technology module (switch control voltage off and on). Error occurs again after control voltage was switched off and on: ⇒ Reload firmware. Error occurs in spite of switching control voltage off and on and reloading firmware: ⇒ Hardware is defective; replace control section.

See also Functional Description of firmware "Firmware Release Update"



Only Rexroth service engineers or especially trained users are allowed to replace the control section. The replacement of the entire drive controller is described in the Project Planning Manual for the power section.



When using the optional module "safety technology I/O" (S1) (up to MPx06) or "Safe Motion" (S2) (as of MPx07), you can, in addition to the error message, obtain detailed information with regard to the cause of the error or the error location. For this purpose, evaluate the parameter "P-0-3219, Diagnostic safety technology message".

Up to MPx06: See "Extended Diagnosis (P-0-3219)".

As of MPx07: See "Extended Diagnosis (P-0-3219) as of MPx07".

F3150 - Attributes	Display:	F3150
	Ident N°:	F3150

Error Messages

8.6.24 F3151 Safety command for system halt incorrect

Allocation	Contained in 02VRS:	«MPB»	«MPH»	«MPD»	
	Contained in 03VRS:	«MPB»	«MPH»	«MPD»	
	Contained in 04VRS:	«MPB»	«MPH»	«MPD»	
	Contained in 05VRS:	«MPB»	«MPH»	«MPD»	
	Contained in 06VRS:	«MPB»	«MPH»	«MPD»	«MPC»
	Contained in 07VRS:	«MPB»	«MPH»	«MPD»	«MPC»
	Contained in 08VRS:	«MPB»	«MPH»	«MPD»	«MPC»
	Supported by supply unit:	«-»			

Channel 2 of the safety technology is switched from operating mode to parameter mode via an internal command. During the command, the necessary initialization steps are carried out in channel 2.

Error Reaction The drive is shut down according to the setting in "P-0-0119, Best possible deceleration". Automatic switching to "safety related standstill" (up to MPx06) or "Safe stop 1" (as of MPx07) takes place and the output stage is switched off via two channels.

Cause	Remedy
Timeout in command processing because other command is active (e.g. C3000)	Start command "S-0-0099, C0500 Reset class 1 diagnostics" in order to clear error and then switch from operating mode to parameter mode. If necessary, reset module by switching control voltage off and on



When using the optional module "safety technology I/O" (S1) (up to MPx06) or "Safe Motion" (S2) (as of MPx07), you can, in addition to the error message, obtain detailed information with regard to the cause of the error or the error location. For this purpose, evaluate the parameter "P-0-3219, Diagnostic safety technology message".

Up to MPx06: See "Extended Diagnosis (P-0-3219)".

As of MPx07: See "Extended Diagnosis (P-0-3219) as of MPx07".

F3151 - Attributes	Display:	F3151
	Ident N°:	F3151

8.6.25 F3152 Incorrect backup of safety technology data

Allocation	Contained in 02VRS:	«MPB»	«MPH»	«MPD»	
	Contained in 03VRS:	«MPB»	«MPH»	«MPD»	
	Contained in 04VRS:	«MPB»	«MPH»	«MPD»	
	Contained in 05VRS:	«MPB»	«MPH»	«MPD»	
	Contained in 06VRS:	«MPB»	«MPH»	«MPD»	«MPC»
	Contained in 07VRS:	«MPB»	«MPH»	«MPD»	«MPC»
	Contained in 08VRS:	«MPB»	«MPH»	«MPD»	«MPC»
	Supported by supply unit:	«-»			

In order to use the same safety technology configuration, after the control section was replaced, without having to carry out safety technology commissioning again, the monitoring of the correct backup or acceptance of the safety technology data is contained in the drive. An error occurred during data backup.

Error Reaction The drive is shut down according to the setting in "P-0-0119, Best possible deceleration". Automatic switching to "safety related standstill" (up to MPx06) or "Safe stop 1" (as of MPx07) takes place and the output stage is switched off via two channels.

Error Messages

Cause	Remedy
Error in hardware or in internal sequence during data back-up	Repeat data backup. If error occurs again, execute command "C0720 Load defaults procedure command (safety technology)". If error occurs again, optional safety technology module or entire drive controller has to be replaced. If error occurs, content of parameter "P-0-3208, Backup of safety techn. data channel 2" is incorrect
Content of parameter "P-0-3208, Backup of safety techn. data channel 2" is incorrect	Check whether correct parameter set, compatible firmware version ("S-0-0030, Manufacturer version"). If error-free "P-0-3208, Backup of safety techn. data channel 2" is not available, safety technology commissioning has to be carried out again



Only Rexroth service engineers or especially trained users are allowed to replace the control section. The replacement of the entire drive controller is described in the Project Planning Manual for the power section.

Only Rexroth service engineers are allowed to replace options of the control section.



When using the optional module "safety technology I/O" (S1) (up to MPx06) or "Safe Motion" (S2) (as of MPx07), you can, in addition to the error message, obtain detailed information with regard to the cause of the error or the error location. For this purpose, evaluate parameter "P-0-3219, Diagnostic safety technology message".

Up to MPx06: See "Extended Diagnosis (P-0-3219)".

As of MPx07: See "Extended Diagnosis (P-0-3219) as of MPx07".

F3152 - Attributes **Display:** F3152
 Ident N°: F3152

8.6.26 F3160 Communication error of safe communication

Allocation	Contained in 02VRS:	«-»	«-»	«-»	
	Contained in 03VRS:	«MPB»	«MPH»	«MPD»	
	Contained in 04VRS:	«MPB»	«MPH»	«MPD»	
	Contained in 05VRS:	«MPB»	«MPH»	«MPD»	
	Contained in 06VRS:	«MPB»	«MPH»	«MPD»	«MPC»
	Contained in 07VRS:	«MPB»	«MPH»	«MPD»	«MPC»
	Contained in 08VRS:	«MPB»	«MPH»	«MPD»	«MPC»
	Supported by supply unit:	«-»			

A cyclic check of the drive has shown that the drive cannot communicate with the master via the safety bus.

Error Reaction The drive is shut down according to the setting in "P-0-0119, Best possible deceleration". Automatic switching to "drive interlock" (up to MPx06) or "Safe stop 1 (Emergency stop)" (as of MPx07) takes place and the output stage is switched off via two channels.

Error Messages

Cause	Remedy
Missing or incorrect connection	Check connection, remove cause of error
Failure of bus master	Remove error of master



When using the optional module "safety technology I/O" (S1) (up to MPx06) or "Safe Motion" (S2) (as of MPx07), you can, in addition to the error message, obtain detailed information with regard to the cause of the error or the error location. For this purpose, evaluate the parameter "P-0-3219, Diagnostic safety technology message".

Up to MPx06: See "Extended Diagnosis (P-0-3219)".

As of MPx07: See "Extended Diagnosis (P-0-3219) as of MPx07".

F3160 - Attributes **Display:** F3160
 Ident N°: F3160

8.7 Non-Fatal Errors (F2xxx)

8.7.1 Behavior in the Case of Non-Fatal Errors

Non-fatal errors are errors that still allow a freely definable, variable error reaction.

Drive Behavior The user can define the drive behavior for the case of non-fatal errors occurring via the setting of the parameters "P-0-0117, Activation of NC reaction on error" and "P-0-0119, Best possible deceleration".

Putting the Drive Into Operation The drive can only be put into operation again when:

1. The error reaction has been completed, i.e. the drive has stopped ($v=0!$).
2. The error message was cleared by the error clearing command (cf. "S-0-0099, C0500 Reset class 1 diagnostics").
3. The cause of the error was removed.
4. Drive enable was switched on again (0-1 edge).

8.7.2 F2002 Assignment of encoder for synchronization is not allowed

Allocation	Contained in 02VRS:	«-»	«-»	«-»	
	Contained in 03VRS:	«-»	«-»	«-»	
	Contained in 04VRS:	«-»	«-»	«-»	
	Contained in 05VRS:	«MPB»	«MPH»	«MPD»	
	Contained in 06VRS:	«MPB»	«MPH»	«MPD»	«MPC»
	Contained in 07VRS:	«MPB»	«MPH»	«MPD»	«MPC»
	Contained in 08VRS:	«MPB»	«MPH»	«MPD»	«MPC»
	Supported by supply unit:	«-»			

When the operation mode "position synchronization" (0x0245) or the operation mode "velocity synchronization" (0x0042) is configured in one of the operation mode parameters (S-0-0032, S-0-0033, etc.), "P-0-0753, Position actual value in actual value cycle" required for synchronization is initialized with regard to the encoder specified by bit0 of parameter "S-0-0520, Control word of axis controller" when switching from parameter mode to operating mode takes place.



If the additive functional package "IndraMotion MLD" has been enabled, the operation mode "position synchronization" and the operation mode "velocity synchronization" are automatically configured as operation modes.

When a synchronous operation mode with outer position control loop ("MotionProfile", "cam" or "phase synchronization") is activated, a check is run to find out whether "P-0-0753, Position actual value in actual value cycle" was initialized with regard to the currently effective control encoder (encoder 1 or encoder 2); if the drive detects that this is not the case, the F2002 error is triggered.

Cause	Remedy
Control encoder valid at activation of synchronous operation mode with outer position control loop is not initialization encoder for actual position value in actual value cycle.	In parameter mode (PM), select, via "S-0-0520, Control word of axis controller", encoder with regard to which "P-0-0753, Position actual value in actual value cycle" is to be initialized. Make sure that, when activating a synchronous operation mode with outer position control loop, control encoder defined via "S-0-0520, Control word of axis controller" is initialization encoder of "P-0-0753, Position actual value in actual value cycle".

F2002 - Attributes Display: F2002
 Ident N°: F2002

8.7.3 F2003 Motion step skipped

Allocation	Contained in 02VRS:	«-»	«-»	«-»	
	Contained in 03VRS:	«-»	«-»	«-»	
	Contained in 04VRS:	«MPB»	«MPH»	«MPD»	
	Contained in 05VRS:	«MPB»	«MPH»	«MPD»	
	Contained in 06VRS:	«MPB»	«MPH»	«MPD»	«MPC»
	Contained in 07VRS:	«MPB»	«MPH»	«MPD»	«MPC»
	Contained in 08VRS:	«MPB»	«MPH»	«MPD»	«MPC»
	Supported by supply unit:	«-»			

When the operating mode "electronic motion profile" is active, a check is run during the transition from one motion step to the next to find out whether a motion step was skipped.

Except for the transition from the last to the first motion step (or vice versa), the motion step number may only change by 1.

Cause	Remedy
Master axis velocity ("P-0-0777, Effective master axis velocity") is so high that master axis distance ("P-0-0227, Cam shaft profile, access angle") covered in one position loop clock is greater than width of one motion step	Reduce master axis velocity - or - Increase width of motion step (distance of two master axis initial positions in "P-0-0705, List of master axis initial positions, set 0" or "P-0-0712, List of master axis initial positions, set 1") - or - Reduce position loop clock (see Functional Description of firmware " Performance Data").

F2003 - Attributes Display: F2003
 Ident N°: F2003

Error Messages

8.7.4 F2004 Error in MotionProfile

Allocation	Contained in 02VRS:	«-»	«-»	«-»	
	Contained in 03VRS:	«-»	«MPH»	«-»	
	Contained in 04VRS:	«MPB»	«MPH»	«MPD»	
	Contained in 05VRS:	«MPB»	«MPH»	«MPD»	
	Contained in 06VRS:	«MPB»	«MPH»	«MPD»	«MPC»
	Contained in 07VRS:	«MPB»	«MPH»	«MPD»	«MPC»
	Contained in 08VRS:	«MPB»	«MPH»	«MPD»	«MPC»
	Supported by supply unit:	«-»			



Up to firmware version MPx05, the name of this error message was "F2004 Error in motion profile".

In the "MotionProfile" mode, the drive monitors whether the defined motion profile (max. 8 individual motion steps) is verisimilar. The error is generated if a motion profile that has not passed the validation checks is activated with the drive having been enabled. Depending on whether set 0 or set 1 was selected, a number is displayed in parameter "P-0-0702, MotionProfile, diagnosis, set 0" or "P-0-0709, MotionProfile, diagnosis, set 1".

Cause	Remedy
1: Master axis initial positions of motion steps used are not increasing	Check list "P-0-0705, List of master axis initial positions, set 0" or "P-0-0712, List of master axis initial positions, set 1"
2: In the case of absolute motion profile, sum of individual distances is not "0" or a multiple of "S-0-0103, Modulo value"	Check list "P-0-0707, List of distances, set 0" or "P-0-0714, List of distances, set 1"
Only up to MPx07: 3: In case of relative motion profile, number of motion steps is smaller than "2"	Check parameter "P-0-0703, Number of motion steps, set 0" or "P-0-0710, Number of motion steps, set 1"
21...28: Checked motion step is "rest in velocity" or "velocity in velocity". Following step consists of profile which is not "velocity in rest" or "velocity in velocity". Number of checked motion step can be taken from second digit of diagnostic message number	Check list "P-0-0706, List of motion laws, set 0"/"P-0-0706, List of motion step modes, set 0" or "P-0-0713, List of motion laws, set 1"/"P-0-0713, List of motion step modes, set 1"
31...38: Checked motion step is "rest in velocity" or "velocity in velocity". Following step consists of profile which is either "velocity in rest" or "velocity in velocity". Velocities of step that was checked and following step do not match. Number of checked motion step can be taken from second digit of diagnostic message number	Check list "P-0-0708, List of slave axis velocities, set 0" or "P-0-0715, List of slave axis velocities, set 1"
41...48: Checked motion step is "velocity in rest" or "velocity in velocity". Previous step consists of profile which is not "rest in velocity" or "velocity in velocity". Number of checked motion step can be taken from second digit of diagnostic message number	Check list "P-0-0706, List of motion laws, set 0"/"P-0-0706, List of motion step modes, set 0" or "P-0-0713, List of motion laws, set 1"/"P-0-0713, List of motion step modes, set 1"

Error Messages

Cause	Remedy
<p>51...58: Checked motion step is "velocity in rest" or "velocity in velocity". Previous step consists of profile which is either "rest in velocity" or "velocity in velocity". Velocities of step that was checked and previous step do not match.</p> <p>Number of checked motion step can be taken from second digit of diagnostic message number</p>	<p>Check list "P-0-0708, List of slave axis velocities, set 0" or "P-0-0715, List of slave axis velocities, set 1"</p>
<p>61...68: 1st table element of a cam table used is unequal "0", cam table is invalid, or wrong table format is set.</p> <p>Number of rejected cam table can be taken from second digit of diagnostic message number</p>	<p>Check list "P-0-0706, List of motion laws, set 0"/"P-0-0706, List of motion step modes, set 0" or "P-0-0713, List of motion laws, set 1"/"P-0-0713, List of motion step modes, set 1".</p> <p>Ensure that the cam table corresponds to the "new" format and the setting in "P-0-0086, Configuration word synchronous operation modes" is selected accordingly.</p>
<p>71...78: Checked motion step is "velocity in rest", "velocity in velocity" or "rest in velocity". Inadmissibly, distance of motion step is "0"</p> <p>Number of checked motion step can be taken from second digit of diagnostic message number</p>	<p>Check list "P-0-0707, List of distances, set 0" or "P-0-0714, List of distances, set 1"</p>
<p>As of MPx05:</p> <p>81...88: Checked motion step is "rest in rest with limited velocity". Indicated maximum slave axis velocity would be exceeded and segmentation into the three partial steps "rest in velocity", "constant velocity" and "velocity in rest" is impossible.</p> <p>Number of checked motion step can be taken from second digit of diagnostic message number</p>	<ul style="list-style-type: none"> • Reduce distance of step (P-0-0707 or P-0-0714) • Increase maximum slave axis velocity (P-0-0708 or P-0-0715) • Reduce master axis velocity (P-0-0704 or P-0-0711)

See also Function Description of firmware "MotionProfile with Real/Virtual Master Axis"

F2004 - Attributes **Display:** F2004
 Ident N°: F2004

8.7.5 F2005 Cam table invalid

Allocation	Contained in 02VRS:	«MPB»	«MPH»	«MPD»	
	Contained in 03VRS:	«MPB»	«MPH»	«MPD»	
	Contained in 04VRS:	«MPB»	«MPH»	«MPD»	
	Contained in 05VRS:	«MPB»	«MPH»	«MPD»	
	Contained in 06VRS:	«MPB»	«MPH»	«MPD»	«MPC»
	Contained in 07VRS:	«MPB»	«MPH»	«MPD»	«MPC»
	Contained in 08VRS:	«MPB»	«MPH»	«MPD»	«MPC»
	Supported by supply unit:	«-»			



Up to firmware version MPx05, the name of this error message was "F2005 Cam shaft invalid".

When the cam mode is active, the drive monitors whether one of the cam tables contains invalid elements or is incomplete.

Error Messages

Cause	Remedy
One of cam tables is invalid	Check cam tables and, if necessary, reload them ("P-0-0072, Cam table 1", "P-0-0092, Cam table 2", "P-0-0780, Cam table 3" or "P-0-0781, Cam table 4"). In case of doubt, contact installation programmer or machine manufacturer

See also Functional Description of firmware "Electronic Cam With Real/Virtual Master Axis"

F2005 - Attributes Display: F2005
 Ident N°: F2005

8.7.6 F2006 MMC was removed

Allocation	Contained in 02VRS:	«MPB»	«MPH»	«MPD»	
	Contained in 03VRS:	«MPB»	«MPH»	«MPD»	
	Contained in 04VRS:	«MPB»	«MPH»	«MPD»	
	Contained in 05VRS:	«MPB»	«MPH»	«MPD»	
	Contained in 06VRS:	«MPB»	«MPH»	«MPD»	«MPC»
	Contained in 07VRS:	«MPB»	«MPH»	«MPD»	«MPC»
	Contained in 08VRS:	«MPB»	«MPH»	«MPD»	«MPC»
	Supported by supply unit:	«-»			

The drive monitors whether the MMC is available when it is used as an active memory, i.e. when the parameters are stored in the MMC.

Cause	Remedy
MMC is used as active memory and was removed from drive controller under voltage	Put MMC in its slot at the drive controller again and then start command "S-0-0099, C0500 Reset class 1 diagnostics" in order to clear error
Loose contact in MMC slot or MMC incorrectly plugged	Check fixing of MMC and, if necessary, plug it in correctly
MMC defective	Replace MMC
MMC slot defective	Replace control section or entire drive controller



Only Rexroth service engineers or especially trained users are allowed to replace the control section. The replacement of the entire drive controller is described in the Project Planning Manual for the power section.

F2006 - Attributes Display: F2006
 Ident N°: F2006

8.7.7 F2007 Switching to non-initialized operation mode

Allocation	Contained in 02VRS:	«MPB»	«MPH»	«MPD»	
	Contained in 03VRS:	«MPB»	«MPH»	«MPD»	
	Contained in 04VRS:	«MPB»	«MPH»	«MPD»	
	Contained in 05VRS:	«MPB»	«MPH»	«MPD»	
	Contained in 06VRS:	«MPB»	«MPH»	«MPD»	«MPC»
	Contained in 07VRS:	«MPB»	«MPH»	«MPD»	«MPC»
	Contained in 08VRS:	«MPB»	«MPH»	«MPD»	«MPC»
	Supported by supply unit:	«-»			

When switching the active operation mode, the drive was switched to a non-initialized operation mode.

For the operation modes that can be selected, please see descriptions of the operation mode parameters:

- S-0-0032, Primary operation mode
- S-0-0033, Secondary operation mode 1
- S-0-0034, Secondary operation mode 2
- S-0-0035, Secondary operation mode 3

As of MPx03, in addition:

- S-0-0284, Secondary operation mode 4
- S-0-0285, Secondary operation mode 5
- S-0-0286, Secondary operation mode 6
- S-0-0287, Secondary operation mode 7

Cause	Remedy
Drive-integrated PLC (IndraMotion MLD) or one of following control words were used to select an operation mode that was not initialized (e.g., S-0-0032="0"): <ul style="list-style-type: none"> • "S-0-0134, Master control word" (with SERCOS) • "P-0-4077, Field bus: control word" (with field bus) • "P-0-4028, Device control word" • "P-0-0120, Control word easy startup" 	Enter desired operation mode in selected operation mode parameter

See also Functional Description of firmware "Selecting the Operation Mode".

F2007 - Attributes **Display:** F2007
 Ident N°: F2007

8.7.8 F2008 RL The motor type has changed.

Allocation	Contained in 02VRS:	«MPB»	«MPH»	«MPD»	
	Contained in 03VRS:	«MPB»	«MPH»	«MPD»	
	Contained in 04VRS:	«MPB»	«MPH»	«MPD»	
	Contained in 05VRS:	«MPB»	«MPH»	«MPD»	
	Contained in 06VRS:	«MPB»	«MPH»	«MPD»	«MPC»
	Contained in 07VRS:	«MPB»	«MPH»	«MPD»	«MPC»
	Contained in 08VRS:	«MPB»	«MPH»	«MPD»	«MPC»
	Supported by supply unit:	«-»			

In the initialization phase (after activation of the drive), the controller checks whether the connected motor corresponds to the type designation in "S-0-0141, Motor type". If not, error F2008 is generated and the controller prompts the user to load the motor-specific control loop parameter values from the encoder memory of the motor (the display of the control panels shows "RL").

Error Messages

Cause	Remedy
<p>Motor was replaced by a different motor type.</p> <p>- or -</p> <p>Parameter "S-0-0141, Motor type" of parameter file loaded to drive controller differs from connected motor type.</p> <p>- or -</p> <p>Drive controller was switched on for first time. Motor type stored in "S-0-0141, Motor type" differs from connected motor type.</p>	<p>Clear error with</p> <p>"S-0-0099, C0500 Reset class 1 diagnostics"</p> <p>- or -</p> <p>Press the "Esc" key on the control panel of controller</p> <p>Note: After this error is cleared, command "S-0-0262, C07_x Load defaults procedure command" is executed unless this was deactivated in "P-0-0556, Config word of axis controller".</p> <p>Attention: Execution of this command causes the existing control loop settings to be overwritten with the default control loop settings from the encoder memory.</p>

See also Functional Description of firmware "Control Panels of the IndraDrive Controllers"

F2008 - Attributes **Display:** RL
Ident N°: F2008

8.7.9 F2009 PL Load parameter default values

Allocation	Contained in 02VRS:	«MPB»	«MPH»	«MPD»	
	Contained in 03VRS:	«MPB»	«MPH»	«MPD»	
	Contained in 04VRS:	«MPB»	«MPH»	«MPD»	
	Contained in 05VRS:	«MPB»	«MPH»	«MPD»	
	Contained in 06VRS:	«MPB»	«MPH»	«MPD»	«MPC»
	Contained in 07VRS:	«MPB»	«MPH»	«MPD»	«MPC»
	Contained in 08VRS:	«MPB»	«MPH»	«MPD»	«MPC»
	Supported by supply unit:	«HMV»			

When the firmware is replaced (firmware update), the non-volatile memory (internal memory or MMC) is automatically analyzed; during the analysis an error was detected.

During the transition checks for the communication phases 3 and 4, the operating data (parameter values) are subsequently verified; parameters with invalid operating data (normally only all new parameters) are output in the parameters "S-0-0021, IDN list of invalid operating data for communication phase 2" or "S-0-0022, IDN list of invalid operating data for communication phase 3".

NOTICE

Property damage caused by unintended overwriting of parameters and positioning blocks!

⇒ Before executing the command for loading the parameter default values by "clear errors", you should save the current parameter set.

Error Messages

Cause	Remedy
Drive is started with new firmware for the first time or a version update was carried out due to which number of non-volatile parameters has changed.	By clearing error via control panel, all parameter values are cleared and set to original values (default values). - or - Error is cleared by starting command "S-0-0099, C0500 Reset class 1 diagnostics". Parameters that can be read from memory remain at their last stored value, all parameters that cannot be read from the memory (new parameters) are set to default values and marked as being invalid. - or - By starting command "S-0-0262, C07_x Load defaults procedure command" with option "Load defaults", F2009 is automatically cleared.
Parameter memory (MMC or internal memory) is defective so that error F2009 keeps reappearing.	Check MMC and replace it, if necessary, or replace control section or entire drive controller.



Only Rexroth service engineers or especially trained users are allowed to replace the control section. The replacement of the entire drive controller is described in the Project Planning Manual for the power section.

See also Functional Description of firmware "Control Panels of the IndraDrive Controllers"

F2009 - Attributes Display: PL
 Ident N°: F2009

8.7.10 F2010 Error when initializing digital I/O (-> S-0-0423)

Allocation	Contained in 02VRS:	«MPB»	«MPH»	«MPD»	
	Contained in 03VRS:	«MPB»	«MPH»	«MPD»	
	Contained in 04VRS:	«MPB»	«MPH»	«MPD»	
	Contained in 05VRS:	«MPB»	«MPH»	«MPD»	
	Contained in 06VRS:	«MPB»	«MPH»	«MPD»	«MPC»
	Contained in 07VRS:	«MPB»	«MPH»	«MPD»	«MPC»
	Contained in 08VRS:	«MPB»	«MPH»	«MPD»	«MPC»
	Supported by supply unit:	«-»			



Up to firmware version 04VRS, the name of the error is "F2010 Error when initializing digital inputs/outputs".

An error occurred during the first initialization of the drive (initialization of digital inputs/outputs).

Error Messages

Cause	Remedy
Conflict with last stored parameters of digital inputs/outputs	<p>Check following parameter contents and correct them, if necessary:</p> <ul style="list-style-type: none"> • P-0-0300, Digital I/Os, assignment list • P-0-0301, Digital I/Os, bit numbers • P-0-0302, Digital I/Os, direction <p>With master communication PL available:</p> <ul style="list-style-type: none"> • S-0-0026, Configuration list signal status word • S-0-0328, Assign list signal status word • S-0-0027, Configuration list signal control word • S-0-0329, Assign list signal control word <p>With optional module MD1 or MD2 available:</p> <ul style="list-style-type: none"> • P-0-0681, Assignment IDN -> parallel output 1 • P-0-0682, Assignment parallel input 1 -> IDN <p>As of firmware version MPx05: You might possibly find some information on incorrectly configured parameters in "S-0-0423, IDN-list of invalid op. data for parameterization level"</p>

F2010 - Attributes **Display:** F2010
Ident N°: F2010

8.7.11 F2011 PLC - Error no. 1

Allocation	Contained in 02VRS:	«-»	«MPH»	«-»	
	Contained in 03VRS:	«MPB»	«MPH»	«-»	
	Contained in 04VRS:	«MPB»	«MPH»	«-»	
	Contained in 05VRS:	«MPB»	«MPH»	«-»	
	Contained in 06VRS:	«MPB»	«MPH»	«-»	«MPC»
	Contained in 07VRS:	«MPB»	«MPH»	«-»	«MPC»
	Contained in 08VRS:	«MPB»	«MPH»	«-»	«MPC»
	Supported by supply unit:	«-»			

In conjunction with technology functions, the PLC integrated in the drive (optional expansion package "Drive PLC") allows the user to generate error messages from within the PLC program.

Occurrence of this error depends on the particular PLC project (or the active technology function). If the error message is generated by a technology function provided by Bosch Rexroth, the causes and remedies can be found in the description of the technology function.

Tip: As of firmware versions MPx08/MPx17, the diagnostic message text can be edited via the integrated PLC. This allows the user to assign meaningful diagnostic messages.

F2011 - Attributes **Display:** F2011
Ident N°: F2011

8.7.12 F2012 PLC - Error no. 2

Allocation	Contained in 02VRS:	«-»	«MPH»	«-»	
	Contained in 03VRS:	«MPB»	«MPH»	«-»	
	Contained in 04VRS:	«MPB»	«MPH»	«-»	
	Contained in 05VRS:	«MPB»	«MPH»	«-»	
	Contained in 06VRS:	«MPB»	«MPH»	«-»	«MPC»
	Contained in 07VRS:	«MPB»	«MPH»	«-»	«MPC»
	Contained in 08VRS:	«MPB»	«MPH»	«-»	«MPC»
	Supported by supply unit:	«-»			

In conjunction with technology functions, the PLC integrated in the drive (optional expansion package "Drive PLC") allows the user to generate error messages from within the PLC program.

Occurrence of this error depends on the particular PLC project (or the active technology function). If the error message is generated by a technology function provided by Bosch Rexroth, the causes and remedies can be found in the description of the technology function.

Tip: As of firmware versions MPx08/MPx17, the diagnostic message text can be edited via the integrated PLC. This allows the user to assign meaningful diagnostic messages.

F2012 - Attributes	Display:	F2012
	Ident N°:	F2012

8.7.13 F2013 PLC - Error no. 3

Allocation	Contained in 02VRS:	«-»	«MPH»	«-»	
	Contained in 03VRS:	«MPB»	«MPH»	«-»	
	Contained in 04VRS:	«MPB»	«MPH»	«-»	
	Contained in 05VRS:	«MPB»	«MPH»	«-»	
	Contained in 06VRS:	«MPB»	«MPH»	«-»	«MPC»
	Contained in 07VRS:	«MPB»	«MPH»	«-»	«MPC»
	Contained in 08VRS:	«MPB»	«MPH»	«-»	«MPC»
	Supported by supply unit:	«-»			

In conjunction with technology functions, the PLC integrated in the drive (optional expansion package "Drive PLC") allows the user to generate error messages from within the PLC program.

Occurrence of this error depends on the particular PLC project (or the active technology function). If the error message is generated by a technology function provided by Bosch Rexroth, the causes and remedies can be found in the description of the technology function.

Tip: As of firmware versions MPx08/MPx17, the diagnostic message text can be edited via the integrated PLC. This allows the user to assign meaningful diagnostic messages.

F2013 - Attributes	Display:	F2013
	Ident N°:	F2013

8.7.14 F2014 PLC - Error no. 4

Allocation	Contained in 02VRS:	«-»	«MPH»	«-»	
	Contained in 03VRS:	«MPB»	«MPH»	«-»	
	Contained in 04VRS:	«MPB»	«MPH»	«-»	
	Contained in 05VRS:	«MPB»	«MPH»	«-»	
	Contained in 06VRS:	«MPB»	«MPH»	«-»	«MPC»
	Contained in 07VRS:	«MPB»	«MPH»	«-»	«MPC»
	Contained in 08VRS:	«MPB»	«MPH»	«-»	«MPC»
	Supported by supply unit:	«-»			

Error Messages

In conjunction with technology functions, the PLC integrated in the drive (optional expansion package "Drive PLC") allows the user to generate error messages from within the PLC program.

Occurrence of this error depends on the particular PLC project (or the active technology function). If the error message is generated by a technology function provided by Bosch Rexroth, the causes and remedies can be found in the description of the technology function.

Tip: As of firmware versions MPx08/MPx17, the diagnostic message text can be edited via the integrated PLC. This allows the user to assign meaningful diagnostic messages.

F2014 - Attributes	Display:	F2014
	Ident N°:	F2014

8.7.15 F2015 PLC - Error no. 5

Allocation	Contained in 02VRS:	«-»	«-»	«-»	
	Contained in 03VRS:	«-»	«-»	«-»	
	Contained in 04VRS:	«-»	«-»	«-»	
	Contained in 05VRS:	«-»	«-»	«-»	
	Contained in 06VRS:	«-»	«-»	«-»	«-»
	Contained in 07VRS:	«-»	«-»	«-»	«-»
	Contained in 08VRS:	«MPB»	«MPH»	«-»	«MPC»
	Supported by supply unit:	«-»			

In conjunction with technology functions, the PLC integrated in the drive (optional expansion package "Drive PLC") allows the user to generate error messages from within the PLC program.

Occurrence of this error depends on the particular PLC project (or the active technology function). If the error message is generated by a technology function provided by Bosch Rexroth, the causes and remedies can be found in the description of the technology function.

Tip: As of firmware versions MPx08/MPx17, the diagnostic message text can be edited via the integrated PLC. This allows the user to assign meaningful diagnostic messages.

F2015 - Attributes	Display:	F2015
	Ident N°:	F2015

8.7.16 F2016 PLC - Error no. 6

Allocation	Contained in 02VRS:	«-»	«-»	«-»	
	Contained in 03VRS:	«-»	«-»	«-»	
	Contained in 04VRS:	«-»	«-»	«-»	
	Contained in 05VRS:	«-»	«-»	«-»	
	Contained in 06VRS:	«-»	«-»	«-»	«-»
	Contained in 07VRS:	«-»	«-»	«-»	«-»
	Contained in 08VRS:	«MPB»	«MPH»	«-»	«MPC»
	Supported by supply unit:	«-»			

In conjunction with technology functions, the PLC integrated in the drive (optional expansion package "Drive PLC") allows the user to generate error messages from within the PLC program.

Occurrence of this error depends on the particular PLC project (or the active technology function). If the error message is generated by a technology function provided by Bosch Rexroth, the causes and remedies can be found in the description of the technology function.

Tip: As of firmware versions MPx08/MPx17, the diagnostic message text can be edited via the integrated PLC. This allows the user to assign meaningful diagnostic messages.

F2016 - Attributes **Display:** F2016
 Ident N°: F2016

8.7.17 F2017 PLC - Error no. 7

Allocation	Contained in 02VRS:	«-»	«-»	«-»	
	Contained in 03VRS:	«-»	«-»	«-»	
	Contained in 04VRS:	«-»	«-»	«-»	
	Contained in 05VRS:	«-»	«-»	«-»	
	Contained in 06VRS:	«-»	«-»	«-»	«-»
	Contained in 07VRS:	«-»	«-»	«-»	«-»
	Contained in 08VRS:	«MPB»	«MPH»	«-»	«MPC»
	Supported by supply unit:	«-»			

In conjunction with technology functions, the PLC integrated in the drive (optional expansion package "Drive PLC") allows the user to generate error messages from within the PLC program.

Occurrence of this error depends on the particular PLC project (or the active technology function). If the error message is generated by a technology function provided by Bosch Rexroth, the causes and remedies can be found in the description of the technology function.

Tip: As of firmware versions MPx08/MPx17, the diagnostic message text can be edited via the integrated PLC. This allows the user to assign meaningful diagnostic messages.

F2017 - Attributes **Display:** F2017
 Ident N°: F2017

8.7.18 F2018 Device overtemperature shutdown

Allocation	Contained in 02VRS:	«MPB»	«MPH»	«MPD»	
	Contained in 03VRS:	«MPB»	«MPH»	«MPD»	
	Contained in 04VRS:	«MPB»	«MPH»	«MPD»	
	Contained in 05VRS:	«MPB»	«MPH»	«MPD»	
	Contained in 06VRS:	«MPB»	«MPH»	«MPD»	«MPC»
	Contained in 07VRS:	«MPB»	«MPH»	«MPD»	«MPC»
	Contained in 08VRS:	«MPB»	«MPH»	«MPD»	«MPC»
	Supported by supply unit:	«HMV»			

The heat sink temperature of the device is monitored by a temperature sensor and a temperature model. When the heat sink temperature has reached the maximum value, the device is switched off in order to protect it against destruction.



Before the error F2018 is triggered, the warning "E2050 Device overtemp. prewarning" is output for 30 seconds.

The error can only be cleared when the device has cooled down.

Cause	Remedy
Overtemperature (heat sink) due to overload of device	Switch drive off and let it cool down. Check mechanical system and drive sizing (on average, working power may not exceed continuous power of drive) For liquid-cooled devices: Check dimensioning of cooling system (see documentation with part number R911309636)
Ambient temperature too high. Specified performance data is valid up to an ambient temperature of 40 °C	Reduce ambient temperature, e.g. by cooling the control cabinet
Heat sink of device is dirty	Clean heat sink

Error Messages

Cause	Remedy
Convection is prevented by other components or mounting position in control cabinet	Mount device vertically and provide sufficient space for ventilating heat sink
Device-internal blower failed	If blower fails, replace device or power section
Failure of air conditioning for control cabinet	Check air conditioning of control cabinet
Incorrect dimensioning of control cabinet with regard to heat dissipation	Check dimensioning of control cabinet
For liquid-cooled devices: No cooling system connected	Connect cooling system
For liquid-cooled devices: Error in cooling system, e.g. coolant pump defective or filter clogged; thereby flow rate too small / inlet temperature of coolant too high	Check cooling system and remove error

See also Functional Description of firmware "Current Limitation Loop".

F2018 - Attributes	Display:	F2018
	Ident N°:	F2018

8.7.19 F2019 Motor overtemperature shutdown

Allocation	Contained in 02VRS:	«MPB»	«MPH»	«MPD»	
	Contained in 03VRS:	«MPB»	«MPH»	«MPD»	
	Contained in 04VRS:	«MPB»	«MPH»	«MPD»	
	Contained in 05VRS:	«MPB»	«MPH»	«MPD»	
	Contained in 06VRS:	«MPB»	«MPH»	«MPD»	«MPC»
	Contained in 07VRS:	«MPB»	«MPH»	«MPD»	«MPC»
	Contained in 08VRS:	«MPB»	«MPH»	«MPD»	«MPC»
	Supported by supply unit:	«-»			

The motor temperature measured by the temperature sensor has reached the limit value in "S-0-0204, Motor shutdown temperature". The drive is immediately decelerated according to the selected error reaction ("P-0-0119, Best possible deceleration") and shut down. The controller outputs F2019.



For MHD, MKD, MKE and LSF motors, "S-0-0204, Motor shutdown temperature" is permanently set and cannot be changed.

The error can only be cleared when the motor has cooled down.

Cause	Remedy
Motor shutdown temperature incorrectly parameterized	Check and correct parameterization of "S-0-0204, Motor shutdown temperature" by means of motor or temperature sensor data sheet
Motor is overloaded. Effective torque demanded from motor has been above allowed continuous torque too long	Check dimensioning of motor. In case of installations that have been operated for a long time, check whether drive conditions have changed (with regard to dirt accumulation, friction, moved masses etc.)
Line interruption, ground fault or short circuit in line for motor temperature monitoring	Check line for motor temperature monitoring for line interruption, ground fault or short circuit
Instability in speed control loop	Check parameterization of speed control loop

Error Messages

Cause	Remedy
For liquid-cooled motors: No cooling system connected	Connect cooling system
For liquid-cooled motors: Error in cooling system, e.g. coolant pump defective or filter clogged; thereby flow rate too small / inlet temperature of coolant too high	Check cooling system and remove error

See also Functional Description of firmware "Motor Temperature Monitoring".

F2019 - Attributes
 Display: F2019
 Ident N°: F2019

8.7.20 F2021 Motor temperature monitor defective

Allocation	Contained in 02VRS:	«MPB»	«MPH»	«MPD»	
	Contained in 03VRS:	«MPB»	«MPH»	«MPD»	
	Contained in 04VRS:	«MPB»	«MPH»	«MPD»	
	Contained in 05VRS:	«MPB»	«MPH»	«MPD»	
	Contained in 06VRS:	«MPB»	«MPH»	«MPD»	«MPC»
	Contained in 07VRS:	«MPB»	«MPH»	«MPD»	«MPC»
	Contained in 08VRS:	«MPB»	«MPH»	«MPD»	«MPC»
	Supported by supply unit:	«-»			

The function of the temperature sensor used for motor temperature monitoring is cyclically monitored by the drive, as soon as the drive is ready for power output ("Ab").

Motors MSK, MAD, MAF When the voltage level of the temperature sensor is outside of the allowed range of values, error F2021 is output for Rexroth motors of the MSK, MAD or MAF lines.

Motors MHD, MKD, MLF, LSF When a voltage suggesting a temperature sensor defect or a contact error has been detected at the temperature sensor input for 30 seconds, error F2021 is output for Rexroth motors of the MHD, MKD, MLF or LSF lines.

Motors 2AD, ADF, 1MB When a voltage suggesting too low motor temperature, a temperature sensor defect or a contact error has been detected at the temperature sensor input for 30 seconds, error F2021 is output for Rexroth motors of the 2AD, ADF or 1MB lines.

The drive reacts to F2021 with the error reaction which has been set or it refuses drive enable.



The error can only be cleared, when its cause has been removed.

Cause	Remedy
Interruption or short circuit in line for motor temperature monitoring	Check motor connection and cable for interruption and short circuit
Temperature sensor in motor is defective	Use replacement temperature sensor (if available) or replace motor
Only for Rexroth motors of lines 2AD, ADF or 1MB: Motor temperature stays below allowed ambient temperature range	Observe minimum allowed ambient temperature (see documentation of respective motor line)
Drive controller defective	Replace drive controller or power section

See also Functional Description of firmware "Motor Temperature Monitoring".

Error Messages

F2021 - Attributes **Display:** F2021
Ident N°: F2021

8.7.21 F2022 Device temperature monitor defective

Allocation	Contained in 02VRS:	«MPB»	«MPH»	«MPD»	
	Contained in 03VRS:	«MPB»	«MPH»	«MPD»	
	Contained in 04VRS:	«MPB»	«MPH»	«MPD»	
	Contained in 05VRS:	«MPB»	«MPH»	«MPD»	
	Contained in 06VRS:	«MPB»	«MPH»	«MPD»	«MPC»
	Contained in 07VRS:	«MPB»	«MPH»	«MPD»	«MPC»
	Contained in 08VRS:	«MPB»	«MPH»	«MPD»	«MPC»
	Supported by supply unit:	«HMV»			

The function of the temperature sensor used for device temperature monitoring is cyclically monitored.

When a temperature equal to or less than -20 °C has been measured for 30 seconds, a defect is supposed to have occurred and the F2022 error is output.

Cause	Remedy
Sensor in drive controller is defective	Replace drive controller or power section

F2022 - Attributes **Display:** F2022
Ident N°: F2022

8.7.22 F2025 Drive not ready for control

Allocation	Contained in 02VRS:	«-»	«-»	«-»	
	Contained in 03VRS:	«-»	«-»	«-»	
	Contained in 04VRS:	«MPB»	«MPH»	«MPD»	
	Contained in 05VRS:	«MPB»	«MPH»	«MPD»	
	Contained in 06VRS:	«MPB»	«MPH»	«MPD»	«MPC»
	Contained in 07VRS:	«MPB»	«MPH»	«MPD»	«MPC»
	Contained in 08VRS:	«MPB»	«MPH»	«MPD»	«MPC»
	Supported by supply unit:	«-»			

When drive enable is set, the drive must be ready; i.e. it must signal the drive status "Ab".

If the drive only signals bb (**betriebsbereit** = ready for operation), i.e. the DC bus voltage is too low or the drive is in parameter mode, the drive generates this error message.

Cause	Remedy
Drive enable (AF) was set before power supply had been switched on - or - Drive enable (AF) was set although drive is still in parameter mode	Check logic for activating drive in connected control unit.

F2025 - Attributes **Display:** F2025
Ident N°: F2025

Error Messages

8.7.25 F2028 Excessive deviation

Allocation	Contained in 02VRS:	«MPB»	«MPH»	«MPD»	
	Contained in 03VRS:	«MPB»	«MPH»	«MPD»	
	Contained in 04VRS:	«MPB»	«MPH»	«MPD»	
	Contained in 05VRS:	«MPB»	«MPH»	«MPD»	
	Contained in 06VRS:	«MPB»	«MPH»	«MPD»	«MPC»
	Contained in 07VRS:	«MPB»	«MPH»	«MPD»	«MPC»
	Contained in 08VRS:	«MPB»	«MPH»	«MPD»	«MPC»
	Supported by supply unit:	«-»			

When the position control loop is closed the drive monitors whether it can follow the preset position command value. To do this a actual model position value is calculated in the drive and compared with the real actual position value. If the difference of calculated and real actual position value exceeds the value entered in parameter "S-0-0159, Monitoring window" it is obvious that the drive cannot follow the preset command value and the error F2028 is generated.



The maximum deviation between calculated and real actual position value can be read from "P-0-0098, Max. model deviation".

Cause	Remedy
Parameterized monitoring window too small	Check and, if necessary, correct content of "S-0-0159, Monitoring window".
Too high command acceleration due to incorrect command value set by control unit	Reduce acceleration value set by the control unit (see control unit manual)
Numeric value in "S-0-0092, Bipolar torque/force limit value" too low	Check content of parameter "S-0-0092, Bipolar torque/force limit value" and set it to maximum value allowed for application.
Axis is blocked or sluggish	Check mechanical system and remove axis blocking.
Incorrect or non-optimized control loop parameters	Check control loop setting (e. g. "S-0-0104, Position loop Kv-factor", "S-0-0100, Velocity loop proportional gain", "P-0-0556, Control word of axis controller").
Acceleration capacity of drive was exceeded	Check drive dimensioning

F2028 - Attributes

Display:

F2028

Ident N°:

F2028

8.7.26 F2031 Encoder 1 error: Signal amplitude incorrect

Allocation	Contained in 02VRS:	«-»	«-»	«-»	
	Contained in 03VRS:	«-»	«-»	«-»	
	Contained in 04VRS:	«MPB»	«MPH»	«MPD»	
	Contained in 05VRS:	«MPB»	«MPH»	«MPD»	
	Contained in 06VRS:	«MPB»	«MPH»	«MPD»	«MPC»
	Contained in 07VRS:	«MPB»	«MPH»	«MPD»	«MPC»
	Contained in 08VRS:	«MPB»	«MPH»	«MPD»	«MPC»
	Supported by supply unit:	«-»			

The signals of the measuring system (encoder 1) are monitored on hardware and software level with regard to their amplitudes and signal shape. If a signal (e.g., sin or cos) leaves the thresholds monitored by the hardware or if the signals are disturbed in such a way that a position error occurs, error F2031 is generated in conjunction with the function "redundant motor encoder".



As the position of the measuring system is no longer generated correctly when error F2031 is detected, it is necessary to initialize the encoder again.

The error can only be cleared in the parameter mode (PM).

Cause	Remedy
Defective encoder cable or cable shielding	Check cable to measuring system and replace it, if necessary
Measuring system defective	Check measuring system and replace it, if necessary
Faulty mounting of measuring head in the case of linear measuring systems	Check mounting of measuring head and correct it, if necessary
Measuring system dirty	Clean or replace measuring system
Hardware defect on control section of drive	Replace control section or entire drive controller



Only Rexroth service engineers or especially trained users are allowed to replace the control section. The replacement of the entire drive controller is described in the Project Planning Manual for the power section.

F2031 - Attributes Display: F2031
 Ident N°: F2031

8.7.27 F2032 Validation error during commutation fine adjustment

Allocation	Contained in 02VRS:	«MPB»	«MPH»	«MPD»	
	Contained in 03VRS:	«MPB»	«MPH»	«MPD»	
	Contained in 04VRS:	«MPB»	«MPH»	«MPD»	
	Contained in 05VRS:	«MPB»	«MPH»	«MPD»	
	Contained in 06VRS:	«MPB»	«MPH»	«MPD»	«MPC»
	Contained in 07VRS:	«MPB»	«MPH»	«MPD»	«MPC»
	Contained in 08VRS:	«MPB»	«MPH»	«MPD»	«MPC»
	Supported by supply unit:	«-»			

When a synchronous motor with incremental measuring system is homed, the value of "P-0-0521, Effective commutation offset" is converted to the home point reference and compared to the optimized commutation offset in P-0-0508, Commutation offset. If the deviation determined due to this comparison is too great, the error F2032 is generated and the drive is shut down.



If the deviation is too great, the operational safety of the motor is no longer guaranteed because a "runaway effect" of the motor can occur.

Cause	Remedy
Initial commissioning was not or incompletely carried out.	Carry out initial commissioning
Motor encoder was replaced	Carry out initial commissioning
Motor connections (U, V, W) were mixed up.	Check and if necessary correct motor connection.
Values in "P-0-0508, Commutation offset" and/or "P-0-3008, Commutation offset, encoder memory" were manipulated.	Check value stored in "P-0-0508, Commutation offset"; carry out initial commissioning again, if required.

See also Functional Description of firmware " Establishing the Position Data Reference (Drive-Controlled Homing)".

Error Messages

F2032 - Attributes **Display:** F2032
Ident N°: F2032

8.7.28 F2033 External power supply X10 error

Allocation	Contained in 02VRS:	«MPB»	«MPH»	«MPD»	
	Contained in 03VRS:	«MPB»	«MPH»	«MPD»	
	Contained in 04VRS:	«MPB»	«MPH»	«MPD»	
	Contained in 05VRS:	«MPB»	«MPH»	«MPD»	
	Contained in 06VRS:	«MPB»	«MPH»	«MPD»	«MPC»
	Contained in 07VRS:	«MPB»	«MPH»	«MPD»	«MPC»
	Contained in 08VRS:	«MPB»	«MPH»	«MPD»	«MPC»
	Supported by supply unit:	«-»			

If the X10 interface at the IndraDrive controller has been equipped with a digital I/O extension "MD1" or "MD2", this requires an external 24 V power supply.



The error can only be cleared, when the external power supply is error-free.

Cause	Remedy
Voltage externally applied is outside of allowed range [and temporary failures (voltage peaks) are detected]	Supply interface with controlled power supply unit
At least one of the inputs was connected with reversed polarity	Check wiring
At least one of the outputs has short circuit	Check wiring
At least one of the outputs is overloaded	Supply motor brake and interface with different power supply units, especially in case of long motor cables
External voltage has not been applied, because digital I/Os are not used	For digital I/O extension "MD1", external 24 V power supply must be connected, even if I/Os are not used. For digital I/O extension "MD2", 24 V monitoring in parameter P-0-0910 can be switched off, if I/Os are not used.

F2033 - Attributes **Display:** F2033
Ident N°: F2033

8.7.29 F2036 Excessive position feedback difference

Allocation	Contained in 02VRS:	«MPB»	«MPH»	«MPD»	
	Contained in 03VRS:	«MPB»	«MPH»	«MPD»	
	Contained in 04VRS:	«MPB»	«MPH»	«MPD»	
	Contained in 05VRS:	«MPB»	«MPH»	«MPD»	
	Contained in 06VRS:	«MPB»	«MPH»	«MPD»	«MPC»
	Contained in 07VRS:	«MPB»	«MPH»	«MPD»	«MPC»
	Contained in 08VRS:	«MPB»	«MPH»	«MPD»	«MPC»
	Supported by supply unit:	«-»			

In cyclic operation, the difference between actual position value 1 and actual position value 2 (see also "P-0-0391, Actual position value difference encoder1 - encoder2") is compared to "S-0-0391, Monitoring window feedback 2". If the absolute value of the difference is greater than the monitoring window, error F2036 is generated.

The drive carries out the error reaction parameterized in "P-0-0119, Best possible deceleration" and the reference bits of both encoders are cleared ("S-0-0403, Position feedback value status").



The monitoring function is inactive if the value "0" was entered in the parameter "S-0-0391, Monitoring window feedback 2".
 The error can only be cleared, when the distance of both encoders is smaller than the monitoring window or the drive is in the parameter mode.

Cause	Remedy
Parameters for encoder 2 incorrect	Check "S-0-0115, Position feedback 2 type" and "S-0-0117, Resolution of feedback 2"
Mechanical system between motor shaft and encoder 2 incorrectly parameterized	Check "S-0-0121, Input revolutions of load gear", "S-0-0122, Output revolutions of load gear" and "S-0-0123, Feed constant"
Mechanical system between motor shaft and encoder 2 is not rigid (e.g., gear backlash, slip) and monitoring window is too small	Increase "S-0-0391, Monitoring window feedback 2", switch off in the case of gear with slip
Maximum allowed slip exceeded with active measuring wheel mode	Check or switch off "P-0-0244, Monitoring window of slip in %"
Encoder cable defective	Replace encoder cable
Maximum input frequency of encoder interface exceeded	Reduce velocity
Encoder 2 not mounted to driven axis	Set "S-0-0391, Monitoring window feedback 2" to "0" (switch monitoring function off)
Incorrect encoder gear settings	Check relevant encoder parameters and correct them, if necessary: <ul style="list-style-type: none"> • "P-0-0121, Gear 1 motor-side (motor encoder)" / "P-0-0122, Gear 1 encoder-side (motor encoder)" • "P-0-0124, Gear 2 load-side (optional encoder)" / "P-0-0125, Gear 2 encoder-side (optional encoder)" • "S-0-0121, Input revolutions of load gear" / "S-0-0122, Output revolutions of load gear"
Position data reference of an absolute encoder incorrect	Execute "P-0-0012, C0300 Set absolute position procedure command"

See also Functional Description of firmware "Position Control with Cyclic Command Value Input"

F2036 - Attributes **Display:** F2036
 Ident N°: F2036

8.7.30 F2037 Excessive position command difference

Allocation	Contained in 02VRS:	«MPB»	«MPH»	«MPD»	
	Contained in 03VRS:	«MPB»	«MPH»	«MPD»	
	Contained in 04VRS:	«MPB»	«MPH»	«MPD»	
	Contained in 05VRS:	«MPB»	«MPH»	«MPD»	
	Contained in 06VRS:	«MPB»	«MPH»	«MPD»	«MPC»
	Contained in 07VRS:	«MPB»	«MPH»	«MPD»	«MPC»
	Contained in 08VRS:	«MPB»	«MPH»	«MPD»	«MPC»
	Supported by supply unit:	«-»			

When the drive is running in the operation mode "position control with cyclic command value input", the incoming position command values (cf. "S-0-0047, Position command value") are monitored. If the position difference between two successive position command values is greater than or equal to

Error Messages

the value in "S-0-0091, Bipolar velocity limit value", the position command value monitor is activated and the error F2037 is generated.

The excessive position command value is stored in parameter "P-0-0010, Excessive position command value".

The last valid position command value is stored in parameter "P-0-0011, Last valid position command value".

Cause	Remedy
Value in "S-0-0091, Bipolar velocity limit value" too low	Check and, if necessary, correct parameterization of "S-0-0091, Bipolar velocity limit value"
Incorrect command value set by control unit	Contact control unit manufacturer or programmer

See also Functional Description of firmware "Position Control with Cyclic Command Value Input"

F2037 - Attributes Display: F2037
 Ident N°: F2037

8.7.31 F2039 Maximum acceleration exceeded

Allocation	Contained in 02VRS:	«MPB»	«MPH»	«MPD»
	Contained in 03VRS:	«MPB»	«MPH»	«MPD»
	Contained in 04VRS:	«MPB»	«MPH»	«MPD»
	Contained in 05VRS:	«MPB»	«MPH»	«MPD»
	Contained in 06VRS:	«-»	«-»	«-»
	Contained in 07VRS:	«-»	«-»	«-»
	Contained in 08VRS:	«-»	«-»	«-»
	Supported by supply unit:	«-»		

In cyclic position control the allowed acceleration limit value was exceeded.



The acceleration monitor can be switched off by means of "P-0-0556, Control word of axis controller".

Cause	Remedy
Value in "S-0-0138, Bipolar acceleration limit value" too low.	Check and, if necessary, correct parameterization of "S-0-0138, Bipolar acceleration limit value".
Incorrect command values set by control unit (position command values).	Contact control unit manufacturer or programmer.
Preset acceleration value was greater than value parameterized in "S-0-0138, Bipolar acceleration limit value".	Reduce acceleration value used <ul style="list-style-type: none"> • S-0-0042, Homing acceleration • S-0-0260, Positioning acceleration • P-0-0057, Return acceleration

F2039 - Attributes Display: F2039
 Ident N°: F2039

8.7.32 F2040 Device overtemperature 2 shutdown

Allocation	Contained in 02VRS:	«MPB»	«MPH»	«MPD»	
	Contained in 03VRS:	«MPB»	«MPH»	«MPD»	
	Contained in 04VRS:	«MPB»	«MPH»	«MPD»	
	Contained in 05VRS:	«MPB»	«MPH»	«MPD»	
	Contained in 06VRS:	«MPB»	«MPH»	«MPD»	«MPC»
	Contained in 07VRS:	«MPB»	«MPH»	«MPD»	«MPC»
	Contained in 08VRS:	«MPB»	«MPH»	«MPD»	«MPC»
	Supported by supply unit:	«-»			

Error Messages

A switch-off values of the second and, if available, third temperature sensor are stored in parameter "P-0-4059, Electric type data of power section".

If "P-0-0816, Amplifier temperature 2" exceeds the switch-off value, error F2040 is generated and the device is switched off.

With HCS04.2: If "P-0-0817, Amplifier temperature 3" exceeds the switch-off value, error F2040 is generated and the device is switched off.



The error can only be cleared when the device has cooled down.

Cause	Remedy
Ambient temperature too high. Specified performance data is valid up to an ambient temperature of 40 °C	Reduce ambient temperature, e.g. by cooling the control cabinet
Heat sink of device is dirty	Clean heat sink
Convection is prevented by other components or mounting position in control cabinet	Mount device vertically and provide sufficient space for ventilating heat sink
Device blower defective	Replace device

F2040 - Attributes Display: F2040
 Ident N°: F2040

8.7.33 F2042 Encoder 2: Encoder signals incorrect

Allocation	Contained in 02VRS:	«MPB»	«MPH»	«MPD»	
	Contained in 03VRS:	«MPB»	«MPH»	«MPD»	
	Contained in 04VRS:	«MPB»	«MPH»	«MPD»	
	Contained in 05VRS:	«MPB»	«MPH»	«MPD»	
	Contained in 06VRS:	«MPB»	«MPH»	«MPD»	«MPC»
	Contained in 07VRS:	«MPB»	«MPH»	«MPD»	«MPC»
	Contained in 08VRS:	«MPB»	«MPH»	«MPD»	«MPC»
	Supported by supply unit:	«-»			

The signals of the measuring system (encoder 2) are monitored on hardware and software level with regard to their amplitudes and signal shape. If a signal (sin or cos) leaves the allowed range or if the signals are disturbed in such a way that a position error occurs, this error is generated.



As the position is no longer generated correctly when this error is detected, the encoder must be re-initialized.

The error can only be cleared, when the signals of the encoder are in the allowed range or the drive is in parameter mode.

Cause	Remedy
Defective encoder cable or cable shielding	Check cable to measuring system and replace it, if necessary
Encoder defective	Check measuring system and replace it, if necessary
Faulty mounting of measuring head in the case of linear measuring systems	Check mounting of measuring head and correct it, if necessary
Measuring system dirty	Replace measuring system
Hardware defect on control section of drive	Replace control section or entire drive controller

Error Messages



Only Rexroth service engineers or especially trained users are allowed to replace the control section. The replacement of the entire drive controller is described in the Project Planning Manual for the power section.

See also "E2075 Encoder 2: Encoder signals disturbed"

F2042 - Attributes

Display: F2042
Ident N°: F2042

8.7.34 F2043 Measuring encoder: Encoder signals incorrect

Allocation	Contained in 02VRS:	«MPB»	«MPH»	«MPD»	
	Contained in 03VRS:	«MPB»	«MPH»	«MPD»	
	Contained in 04VRS:	«MPB»	«MPH»	«MPD»	
	Contained in 05VRS:	«MPB»	«MPH»	«MPD»	
	Contained in 06VRS:	«MPB»	«MPH»	«MPD»	«MPC»
	Contained in 07VRS:	«MPB»	«MPH»	«MPD»	«MPC»
	Contained in 08VRS:	«MPB»	«MPH»	«MPD»	«MPC»
	Supported by supply unit:	«-»			

The signals of the measuring system (measuring encoder) are monitored on hardware and software level with regard to their amplitudes and signal shape. If a signal (e.g., sin or cos) leaves the allowed range or if the signals are disturbed in such a way that a position error occurs, this error is generated.



As the position is no longer generated correctly when this error is detected, the encoder must be re-initialized.

The error can only be cleared, when the signals of the encoder are in the allowed range or the drive is in parameter mode.

Cause	Remedy
Defective encoder cable or cable shielding	Check cable to measuring system and replace it, if necessary
Encoder defective	Check measuring system and replace it, if necessary
Faulty mounting of measuring head in the case of linear measuring systems	Check mounting of measuring head and correct it, if necessary
Measuring system dirty	Replace measuring system
Hardware defect on control section of drive	Replace control section or entire drive controller



Only Rexroth service engineers or especially trained users are allowed to replace the control section. The replacement of the entire drive controller is described in the Project Planning Manual for the power section.

See also "E2076 Measuring encoder: Encoder signals disturbed"

F2043 - Attributes

Display: F2043
Ident N°: F2043

8.7.35 F2044 External power supply X15 error

Allocation	Contained in 02VRS:	«MPB»	«MPH»	«MPD»	
	Contained in 03VRS:	«MPB»	«MPH»	«MPD»	
	Contained in 04VRS:	«MPB»	«MPH»	«MPD»	
	Contained in 05VRS:	«MPB»	«MPH»	«MPD»	
	Contained in 06VRS:	«MPB»	«MPH»	«MPD»	«MPC»
	Contained in 07VRS:	«MPB»	«MPH»	«MPD»	«MPC»
	Contained in 08VRS:	«MPB»	«MPH»	«MPD»	«MPC»
	Supported by supply unit:	«-»			

The drive monitors the digital IOs of the "Parallel interface - PL" master communication.



As of MPx08, P-0-4089.0.1="2" can be used to deactivate the function of monitoring the digital IOs of the "Parallel interface - PL" master communication.



The error can only be cleared, when the external power supply is error-free.

Cause	Remedy
24-V voltage supply of one or more input/output groups is missing or is outside of 19 V to 30 V range	Ensure that all 4 input/output groups are supplied with voltage between 19 V and 30 V
Temporary failures (voltage peaks) or voltage drops	Use controlled power supply unit
At least one of the inputs was connected with reversed polarity	Check wiring incl. cable and correct it, if necessary
At least one of the outputs has short circuit or is overloaded	Check wiring incl. cable and remove short circuit, if necessary
Voltage drops because motor brake applied	Supply motor brake and interface with different power supply units, especially in case of long motor cables

F2044 - Attributes Display: F2044
 Ident N°: F2044

8.7.36 F2048 Low battery voltage

Allocation	Contained in 02VRS:	«MPB»	«MPH»	«MPD»	
	Contained in 03VRS:	«MPB»	«MPH»	«MPD»	
	Contained in 04VRS:	«MPB»	«MPH»	«MPD»	
	Contained in 05VRS:	«MPB»	«MPH»	«MPD»	
	Contained in 06VRS:	«MPB»	«MPH»	«MPD»	«MPC»
	Contained in 07VRS:	«MPB»	«MPH»	«MPD»	«MPC»
	Contained in 08VRS:	«MPB»	«MPH»	«MPD»	«MPC»
	Supported by supply unit:	«-»			



The battery was designed for a service life of 10 years in its installed state.

In the case of Rexroth motors of the MKD/MKE line, the absolute position information is maintained, by means of battery-buffered electronics in the motor feedback, even when the drive controller has been switched off. The battery voltage is checked in the transition command from parameter to operating mode during the initialization of the drive.

Error Messages

 As long as the drive is locked with a customer password, the error F2048 cannot be cleared!

⚠ CAUTION Error when controlling motors and moving parts!

When the error occurs for the first time, the absolute encoder function is only guaranteed for approx. another **2 weeks!**

Replace battery immediately!

Cause	Remedy
Battery voltage has fallen below 3.1 V	Clear error and immediately arrange for and prepare replacement of battery (see instructions in Project Planning Manual for respective motor). For replacement of battery observe warning notice below!
Battery voltage has fallen below 2.8 V	Error cannot be cleared any longer. Battery must be replaced immediately (see instructions in Project Planning Manual for respective motor). For replacement of battery observe warning notice below!

⚠ DANGER Lethal electric shock caused by live parts with more than 50 V!

⇒ The battery must be replaced with the control voltage switched on. The replacement of the battery may only be carried out by a qualified electrician.

 If the control voltage is switched off after the battery was removed, the absolute position data reference gets lost. The position data reference then has to be reestablished.

See also Functional Description of firmware " Establishing the Position Data Reference".

F2048 - Attributes
 Display: F2048
 Ident N°: F2048

8.7.37 F2050 Overflow of target position preset memory

Allocation	Contained in 02VRS:	«MPB»	«MPH»	«MPD»	
	Contained in 03VRS:	«MPB»	«MPH»	«MPD»	
	Contained in 04VRS:	«MPB»	«MPH»	«MPD»	
	Contained in 05VRS:	«MPB»	«MPH»	«MPD»	
	Contained in 06VRS:	«MPB»	«MPH»	«MPD»	«MPC»
	Contained in 07VRS:	«MPB»	«MPH»	«MPD»	«MPC»
	Contained in 08VRS:	«MPB»	«MPH»	«MPD»	«MPC»
	Supported by supply unit:	«-»			

In the case of drive-controlled positioning it is possible to preset a new positioning command value $x(k+1)$ while the drive is moving to the target position of the last positioning command value $x(k)$. The new positioning command value is stored in an input buffer (target position preset memory) and is not cleared until it has been accepted.

Cause	Remedy
There was an attempt to preset a new positioning command value $x(k+2)$ while drive was moving to target position of positioning command value $x(k)$	Check command value in control unit and make sure that new positioning command value $x(k+2)$ is only preset when positioning command value $x(k+1)$ was accepted and drive moves to corresponding target position
Incorrect command value acceptance (toggling of "S-0-0346, Positioning control word") in control unit causes positioning command value to be accepted several times	Check control program and only toggle bit 0 of "S-0-0346, Positioning control word" once for each new positioning command value, because every change of the bit causes current positioning command value to be accepted.
Incorrect positioning mode for "approaching target" was set in "S-0-0346, Positioning control word".	Set positioning mode "immediately moving to new target" for "approaching target" in "S-0-0346, Positioning control word".

See also Functional Description of firmware " Drive-Controlled Positioning".

F2050 - Attributes **Display:** F2050
 Ident N°: F2050

8.7.38 F2051 No sequential block in target position preset memory

Allocation	Contained in 02VRS:	«MPB»	«MPH»	«MPD»	
	Contained in 03VRS:	«MPB»	«MPH»	«MPD»	
	Contained in 04VRS:	«MPB»	«MPH»	«MPD»	
	Contained in 05VRS:	«MPB»	«MPH»	«MPD»	
	Contained in 06VRS:	«MPB»	«MPH»	«MPD»	«MPC»
	Contained in 07VRS:	«MPB»	«MPH»	«MPD»	«MPC»
	Contained in 08VRS:	«MPB»	«MPH»	«MPD»	«MPC»
	Supported by supply unit:	«-»			

In the case of the positioning block mode "sequential block without intermediate stop" the drive is monitoring whether a new positioning block is available in the target position preset memory when the target position has been reached.

Cause	Remedy
When target position of a sequential block has been reached, there is no new positioning block in target position preset memory	Preset sequential block in time (before target position has been reached)
Positioning block mode by mistake set to "sequential block without intermediate stop".	Check positioning block mode and switch off sequential block processing, if necessary ("S-0-0346, Positioning control word").

See also Functional Description of firmware " Drive-Controlled Positioning".

See also Functional Description of firmware " Positioning Block Mode".

F2051 - Attributes **Display:** F2051
 Ident N°: F2051

8.7.39 F2053 Incr. encoder emulator: Pulse frequency too high

Allocation	Contained in 02VRS:	«MPB»	«MPH»	«MPD»	
	Contained in 03VRS:	«MPB»	«MPH»	«MPD»	
	Contained in 04VRS:	«MPB»	«MPH»	«MPD»	
	Contained in 05VRS:	«MPB»	«MPH»	«MPD»	
	Contained in 06VRS:	«MPB»	«MPH»	«MPD»	«MPC»
	Contained in 07VRS:	«MPB»	«MPH»	«MPD»	«MPC»
	Contained in 08VRS:	«MPB»	«MPH»	«MPD»	«MPC»
	Supported by supply unit:	«-»			

The number of increments or lines output within the position loop cycle (Basic: TA = 500 μs, Advanced: TA = 250 μs) is monitored in the drive in or-

Error Messages

der to make sure that the maximum allowed frequency of the incremental encoder signals of 1024 kHz is not exceeded; otherwise a position offset would be produced due to "lost increments".



The maximum allowed frequency of the incremental encoder signals also has to be taken into account for dimensioning the subsequent evaluation electronics in the control unit!

Cause	Remedy
Resolution set in "P-0-0903, Encoder emulation resolution" is too high for existing travel velocity.	Reduce number of increments of incremental encoder emulator in "P-0-0903, Encoder emulation resolution" - or - Reduce travel velocity.

See also Functional Description of firmware " Incremental Encoder Emulation".

F2053 - Attributes Display: F2053
 Ident N°: F2053

8.7.40 F2054 Incr. encoder emulator: Hardware error

Allocation	Contained in 02VRS:	«MPB»	«MPH»	«MPD»	
	Contained in 03VRS:	«MPB»	«MPH»	«MPD»	
	Contained in 04VRS:	«MPB»	«MPH»	«MPD»	
	Contained in 05VRS:	«MPB»	«MPH»	«MPD»	
	Contained in 06VRS:	«MPB»	«MPH»	«MPD»	«MPC»
	Contained in 07VRS:	«MPB»	«MPH»	«MPD»	«MPC»
	Contained in 08VRS:	«MPB»	«MPH»	«MPD»	«MPC»
	Supported by supply unit:	«-»			

In the case of incremental encoder emulation, a check is run at the end of each output interval (= position loop clock) to find out whether all increments to be output have been output before the next increment output is started. Exceeding the run time or hardware errors can cause overlapping that is detected during the check and signaled by the error message F2054.

Cause	Remedy
Run time internally exceeded	Switch off all functions not required (e.g. analog output). If this does not remove error, replace control section or entire drive controller and contact our service department.
Hardware error	Replace control section or entire drive controller and contact our service department.



Only Rexroth service engineers or especially trained users are allowed to replace the control section. The replacement of the entire drive controller is described in the Project Planning Manual for the power section.

See also Functional Description of firmware Incremental Encoder Emulation.

F2054 - Attributes Display: F2054
 Ident N°: F2054

8.7.41 F2055 External power supply dig. I/O error

Allocation	Contained in 02VRS:	«-»	«-»	«-»	
	Contained in 03VRS:	«MPB»	«MPH»	«MPD»	
	Contained in 04VRS:	«MPB»	«MPH»	«MPD»	
	Contained in 05VRS:	«MPB»	«MPH»	«MPD»	
	Contained in 06VRS:	«MPB»	«MPH»	«MPD»	«MPC»
	Contained in 07VRS:	«MPB»	«MPH»	«MPD»	«MPC»
	Contained in 08VRS:	«MPB»	«MPH»	«MPD»	«MPC»
	Supported by supply unit:	«-»			

In case of "High" control of one or several digital outputs of the interfaces X31/X32 at the drive controller (assigned in "P-0-0300, Digital I/Os, assignment list"), there is no "High" signal (+DC24 V) output.



The error can only be cleared, when the external power supply is error-free.

Cause	Remedy
Output or outputs are overloaded Only IndraDrive Mi as of firmware MPB05V06: Overloaded outputs are switched off to avoid hardware defect	Reduce load of output
24-V supply of interfaces X31/X32 has not been connected	Connect 24-V supply
Short-circuited output or outputs	Remove short circuit/short circuits

See also Functional Description of firmware "Digital Inputs/Outputs"

F2055 - Attributes	Display:	F2055
	Ident N°:	F2055

8.7.42 F2057 Target position out of travel range

Allocation	Contained in 02VRS:	«-»	«-»	«-»	
	Contained in 03VRS:	«MPB»	«MPH»	«MPD»	
	Contained in 04VRS:	«MPB»	«MPH»	«MPD»	
	Contained in 05VRS:	«MPB»	«MPH»	«MPD»	
	Contained in 06VRS:	«MPB»	«MPH»	«MPD»	«MPC»
	Contained in 07VRS:	«MPB»	«MPH»	«MPD»	«MPC»
	Contained in 08VRS:	«MPB»	«MPH»	«MPD»	«MPC»
	Supported by supply unit:	«-»			

In operation modes with internal position command value generation a check is run, before a movement is carried out, in order to find out whether the pre-set target position ("S-0-0258, Target position", S-0-0282, Positioning command value or P-0-4006, Positioning block target position [i]) is within the allowed travel range of the drive. The error F2057 was generated because the preset target position is outside of the allowed travel range.

The allowed travel range of the drive is defined by

- S-0-0049, Positive position limit value
- S-0-0050, Negative position limit value
- S-0-0278, Maximum travel range

The position limit value monitor and thus the monitoring of the allowed travel range can be activated / deactivated in "S-0-0055, Position polarities".

The reaction to a travel range error can be set in "P-0-0090, Travel range limit parameter".

Error Messages

Cause	Remedy
Position limit values ("S-0-0049, Positive position limit value", "S-0-0050, Negative position limit value") incorrectly parameterized	Check parameterization of position limit values and adjust it according to desired travel range ("S-0-0049, Positive position limit value" has to be greater than "S-0-0050, Negative position limit value")
Position limit value monitor has been activated although it is not needed	Deactivate position limit value monitor if it is not needed (e.g., in modulo operation)
In the case of relative interpolation, value for travel range was set too high or several travel ranges that are added cause effective target position (cf. "S-0-0430, Effective target position") to be outside of position limits	Check preset travel range (cf. "S-0-0258, Target position") and, if necessary, adjust it in control unit program
In the case of absolute interpolation, preset target position is incorrect	Check preset target position (cf. "S-0-0258, Target position" or "S-0-0282, Positioning command value") and, if necessary, adjust it in control unit program (only enter "S-0-0258, Target position" within position limit values)
In "positioning block mode" one or more target positions have been incorrectly parameterized or incorrect positioning block is selected	Check parameterized target positions in "P-0-4006, Positioning block target position" and block selection (P-0-4026, Positioning block selection). In addition, check block selection via respective master communication (e.g., field bus or digital I/Os).

See also Functional Description of firmware "Position Limitation/Travel Range Limit Switches"

For "relative interpolation", see Functional Description of firmware "Drive-Controlled Positioning"

For "absolute interpolation", see Functional Description of firmware "Drive-Internal Interpolation"

F2057 - Attributes
Display: F2057
Ident N°: F2057

8.7.43 F2058 Internal overflow by positioning input

Allocation	Contained in 02VRS:	«MPB»	«MPH»	«MPD»	
	Contained in 03VRS:	«MPB»	«MPH»	«MPD»	
	Contained in 04VRS:	«MPB»	«MPH»	«MPD»	
	Contained in 05VRS:	«MPB»	«MPH»	«MPD»	
	Contained in 06VRS:	«MPB»	«MPH»	«MPD»	«MPC»
	Contained in 07VRS:	«MPB»	«MPH»	«MPD»	«MPC»
	Contained in 08VRS:	«MPB»	«MPH»	«MPD»	«MPC»
	Supported by supply unit:	«-»			

In operating modes that are using the internal path generator (interpolation, positioning, positioning block mode and spindle positioning), the residual path to be traveled and the braking distance are monitored to find out whether the numeric range is exceeded.

Error Messages

8.7.45 F2063 Internal overflow master axis generator

Allocation	Contained in 02VRS:	«-»	«-»	«-»	
	Contained in 03VRS:	«-»	«-»	«-»	
	Contained in 04VRS:	«MPB»	«MPH»	«MPD»	
	Contained in 05VRS:	«MPB»	«MPH»	«MPD»	
	Contained in 06VRS:	«MPB»	«MPH»	«MPD»	«MPC»
	Contained in 07VRS:	«MPB»	«MPH»	«MPD»	«MPC»
	Contained in 08VRS:	«MPB»	«MPH»	«MPD»	«MPC»
	Supported by supply unit:	«-»			

The residual path to be traveled and the braking distance are monitored to find out whether the numeric range is exceeded.

Cause	Remedy
Braking distance of axis is greater than position value range that can be displayed. Deceleration value that was set ("P-0-0771, Virtual master axis, positioning acceleration") is too low.	Increase "P-0-0771, Virtual master axis, positioning acceleration"
Braking distance of axis is greater than position value range that can be displayed. Velocity value that was set ("P-0-0770, Virtual master axis, positioning velocity") is too high.	Reduce "P-0-0770, Virtual master axis, positioning velocity"

F2063 - Attributes Display: F2063
 Ident N°: F2063

8.7.46 F2064 Incorrect cmd value direction master axis generator

Allocation	Contained in 02VRS:	«-»	«-»	«-»	
	Contained in 03VRS:	«-»	«-»	«-»	
	Contained in 04VRS:	«MPB»	«MPH»	«MPD»	
	Contained in 05VRS:	«MPB»	«MPH»	«MPD»	
	Contained in 06VRS:	«MPB»	«MPH»	«MPD»	«MPC»
	Contained in 07VRS:	«MPB»	«MPH»	«MPD»	«MPC»
	Contained in 08VRS:	«MPB»	«MPH»	«MPD»	«MPC»
	Supported by supply unit:	«-»			

With the internal master axis generator it is possible to jog the virtual master axis in both directions and preset relative distances in both directions.

Cause	Remedy
Due to setting in "P-0-0756, Virtual master axis, scaling type", position data of virtual master axis are to be processed in modulo format and positive or negative rotational direction was selected in "P-0-0769, Virtual master axis, command value mode". Input command value leads to wrong direction.	Input command value direction according to parameter setting in "P-0-0769, Virtual master axis, command value mode".

F2064 - Attributes Display: F2064
 Ident N°: F2064

8.7.47 F2067 Synchronization to master communication incorrect

Allocation	Contained in 02VRS:	«MPB»	«MPH»	«MPD»	
	Contained in 03VRS:	«MPB»	«MPH»	«MPD»	
	Contained in 04VRS:	«MPB»	«MPH»	«MPD»	
	Contained in 05VRS:	«MPB»	«MPH»	«MPD»	
	Contained in 06VRS:	«MPB»	«MPH»	«MPD»	«MPC»
	Contained in 07VRS:	«MPB»	«MPH»	«MPD»	«MPC»
	Contained in 08VRS:	«MPB»	«MPH»	«MPD»	«MPC»
	Supported by supply unit:	«-»			

The drive control is synchronized to the bus interface (SERCOS, Profibus, Interbus, ...) via two phase control loops (Phase Locked Loop - PLL). The correct function of the synchronization is monitored by monitoring the respective control deviation of the two PLLs for an allowed threshold. When the threshold is exceeded this error message is generated.

Cause	Remedy
Interference injection due to incorrect connection of master communication cause synchronization problems.	Check connection of master communication (incl. shield connection) and correct it, if necessary.
Synchronization clock of master oscillates very much due to software or hardware error in master (e.g. jitter of MST with SERCOS).	Check field bus master and make sure synchronization clock is good and constant.
Master communication hardware of drive controller is defective (e.g. optional SERCOS card).	Replace control section or entire drive controller.



Only Rexroth service engineers or especially trained users are allowed to replace the control section. The replacement of the entire drive controller is described in the Project Planning Manual for the power section.

See also Functional Description of firmware "Master Communication".

F2067 - Attributes	Display:	F2067
	Ident N°:	F2067

8.7.48 F2068 Brake error

Allocation	Contained in 02VRS:	«-»	«-»	«-»	
	Contained in 03VRS:	«-»	«-»	«-»	
	Contained in 04VRS:	«-»	«-»	«-»	
	Contained in 05VRS:	«MPB»	«MPH»	«MPD»	
	Contained in 06VRS:	«MPB»	«MPH»	«MPD»	«MPC»
	Contained in 07VRS:	«MPB»	«MPH»	«MPD»	«MPC»
	Contained in 08VRS:	«MPB»	«MPH»	«MPD»	«MPC»
	Supported by supply unit:	«-»			

The holding brake current is monitored when the holding brake has been controlled. If the holding brake current is outside of the allowed range, the error F2068 is generated.

Furthermore, the holding brake of controllers of the IndraDrive Cs type is monitored for wire break. If wire break has occurred, the error F2068 is generated, too.

If the activation of brake control causes problems with wire break monitoring, wire break monitoring can be deactivated (see "P-0-0525, Holding brake control word").

Error Messages

Cause	Remedy
Supply voltage for holding brake has not been correctly connected or is outside of tolerance (24 V +/-5 %)	Check supply voltage
Motor cable has been incompletely connected	Check motor cable
Motor holding brake is defective	Replace motor
Drive controller is defective	Replace drive controller



Controllers of type IndraDrive Cs: The error F2068 can only be cleared by switching off the supply voltage for the holding brake!

See also Functional Description of firmware "Motor Holding Brake"

F2068 - Attributes
 Display: F2068
 Ident N°: F2068

8.7.49 F2069 Error when releasing the motor holding brake

Allocation	Contained in 02VRS:	«MPB»	«MPH»	«MPD»	
	Contained in 03VRS:	«MPB»	«MPH»	«MPD»	
	Contained in 04VRS:	«MPB»	«MPH»	«MPD»	
	Contained in 05VRS:	«MPB»	«MPH»	«MPD»	
	Contained in 06VRS:	«MPB»	«MPH»	«MPD»	«MPC»
	Contained in 07VRS:	«MPB»	«MPH»	«MPD»	«MPC»
	Contained in 08VRS:	«MPB»	«MPH»	«MPD»	«MPC»
	Supported by supply unit:	«-»			

During the automatic check of the holding brake ("P-0-0525, Holding brake control word"), after drive enable or after the start of the "P-0-0541, C2100 Brake check command" the motor did not move, although half the holding torque was produced.



The result of the brake check is displayed in "P-0-0539, Holding brake status word".

Cause	Remedy
Motor brake (servo brake) was not or incorrectly connected.	Connect brake or correct connection
Axis is mechanically blocked	Check mechanical system and remove blocking
Brake is defective	Check and, if necessary, replace brake
Brake supply error	Check voltage
Friction torque of axis is greater than test torque of drive.	Deactivate brake check ("P-0-0525, Holding brake control word") because it cannot be used due to mechanical properties.

F2069 - Attributes
 Display: F2069
 Ident N°: F2069

8.7.50 F2074 Actual pos. value 1 outside absolute encoder window

Allocation	Contained in 02VRS:	«MPB»	«MPH»	«MPD»	
	Contained in 03VRS:	«MPB»	«MPH»	«MPD»	
	Contained in 04VRS:	«MPB»	«MPH»	«MPD»	
	Contained in 05VRS:	«MPB»	«MPH»	«MPD»	
	Contained in 06VRS:	«MPB»	«MPH»	«MPD»	«MPC»
	Contained in 07VRS:	«MPB»	«MPH»	«MPD»	«MPC»
	Contained in 08VRS:	«MPB»	«MPH»	«MPD»	«MPC»
	Supported by supply unit:	«-»			

When switching off a drive with a motor encoder that can be evaluated in absolute form, the current actual position is stored in the drive. When switching the drive on again, the current position is compared to the position stored when the drive was switched off the last time. If the deviation is greater than the value in "P-0-0095, Absolute encoder monitoring window for motor encoder", the error message F2074 is generated.



The monitoring function can be switched off by "P-0-0095, Absolute encoder monitoring window for motor encoder"="0".

Cause	Remedy
While switched off, axis was moved by more than value entered in "P-0-0095, Absolute encoder monitoring window for motor encoder".	Make sure displayed position is correct in relation to machine zero point. Then clear error and, if necessary, reestablish position data reference
Value entered in "P-0-0095, Absolute encoder monitoring window for motor encoder" is too low for existing encoder resolution so that normal encoder jitter already causes monitor to be triggered	Check parameterization of "P-0-0095, Absolute encoder monitoring window for motor encoder" and increase monitoring window
Amplifier replaced without parameter update	Clear error and establish position data reference
Change in parameters of mechanical system (gear, feed constant, ...)	Clear error and establish position data reference
Motor encoder defective	Replace motor or motor encoder

⚠ WARNING

Risk of accident caused by unwanted axis motion!

⇒ Check position data reference. The encoder is defective if the position data reference is incorrect! Replace the motor and send it to the manufacturer's service department for inspection.

F2074 - Attributes	Display:	F2074
	Ident N°:	F2074

8.7.51 F2075 Actual pos. value 2 outside absolute encoder window

Allocation	Contained in 02VRS:	«MPB»	«MPH»	«MPD»	
	Contained in 03VRS:	«MPB»	«MPH»	«MPD»	
	Contained in 04VRS:	«MPB»	«MPH»	«MPD»	
	Contained in 05VRS:	«MPB»	«MPH»	«MPD»	
	Contained in 06VRS:	«MPB»	«MPH»	«MPD»	«MPC»
	Contained in 07VRS:	«MPB»	«MPH»	«MPD»	«MPC»
	Contained in 08VRS:	«MPB»	«MPH»	«MPD»	«MPC»
	Supported by supply unit:	«-»			

When switching off a drive with an external encoder that can be evaluated in absolute form, the current actual position is stored in the drive. When switch-

Error Messages

ing the drive on again, the current position is compared to the position stored when the drive was switched off the last time. If the deviation is greater than the value in "P-0-0096, Absolute encoder monitoring window for opt. encoder", the error message F2075 is generated.



By means of "P-0-0096, Absolute encoder monitoring window for opt. encoder", the monitoring function can be switched off.

Cause	Remedy
While switched off, axis was moved by more than value entered in "P-0-0096, Absolute encoder monitoring window for opt. encoder"	Make sure displayed position is correct in relation to machine zero point. Then clear error and, if necessary, reestablish position data reference
Value entered in "P-0-0096, Absolute encoder monitoring window for opt. encoder" is too low for existing encoder resolution so that normal encoder jitter will already cause monitor to be triggered.	Check parameterization of "P-0-0096, Absolute encoder monitoring window for opt. encoder" and increase monitoring window
Encoder defective or encoder replacement	Replace encoder, clear error and establish position data reference
Amplifier replaced without parameter update	Clear error and establish position data reference
Change in parameters of mechanical system (gear, feed constant, ...)	Clear error and establish position data reference

⚠ WARNING

Risk of accident caused by unwanted axis motion!

⇒ Check position data reference. The encoder is defective if the position data reference is incorrect! Replace the encoder and send it to the manufacturer's service department for inspection.

F2075 - Attributes

Display: F2075
Ident N°: F2075

8.7.52 F2076 Actual pos. value 3 outside absolute encoder window

Allocation	Contained in 02VRS:	«MPB»	«MPH»	«MPD»	
	Contained in 03VRS:	«MPB»	«MPH»	«MPD»	
	Contained in 04VRS:	«MPB»	«MPH»	«MPD»	
	Contained in 05VRS:	«MPB»	«MPH»	«MPD»	
	Contained in 06VRS:	«MPB»	«MPH»	«MPD»	«MPC»
	Contained in 07VRS:	«MPB»	«MPH»	«MPD»	«MPC»
	Contained in 08VRS:	«MPB»	«MPH»	«MPD»	«MPC»
	Supported by supply unit:	«-»			

When switching off a drive with a measuring encoder that can be evaluated in absolute form, the current actual position is stored in the drive. When switching the drive on again, the current position is compared to the position stored when the drive was switched off the last time. If the deviation is greater than the value in "P-0-0097, Absolute encoder monitoring window for measuring encoder", the error message F2076 is generated.



The monitoring function can be switched off by "P-0-0097, Absolute encoder monitoring window for measuring encoder"="0".

Error Messages

Cause	Remedy
While switched off, axis was moved by more than value entered in "P-0-0097, Absolute encoder monitoring window for measuring encoder".	Make sure displayed position is correct in relation to machine zero point. Then clear error and, if necessary, reestablish position data reference
Value entered in "P-0-0097, Absolute encoder monitoring window for measuring encoder" is too low for existing encoder resolution so that normal encoder jitter already causes monitor to be triggered	Check parameterization of "P-0-0097, Absolute encoder monitoring window for measuring encoder" and increase monitoring window
Encoder defective or encoder replacement	Replace encoder, clear error and establish position data reference
Amplifier replaced without parameter update	Clear error and establish position data reference
Change in parameters of mechanical system (gear, feed constant, ...)	Clear error and establish position data reference

⚠ WARNING Risk of accident caused by unwanted axis motion!

⇒ Check position data reference. The encoder is defective if the position data reference is incorrect! Replace the encoder and send it to the manufacturer's service department for inspection.

F2076 - Attributes Display: F2076
 Ident N°: F2076

8.7.53 F2077 Current measurement trim wrong

Allocation	Contained in 02VRS:	«MPB»	«MPH»	«MPD»	
	Contained in 03VRS:	«MPB»	«MPH»	«MPD»	
	Contained in 04VRS:	«MPB»	«MPH»	«MPD»	
	Contained in 05VRS:	«MPB»	«MPH»	«MPD»	
	Contained in 06VRS:	«MPB»	«MPH»	«MPD»	«MPC»
	Contained in 07VRS:	«MPB»	«MPH»	«MPD»	«MPC»
	Contained in 08VRS:	«MPB»	«MPH»	«MPD»	«MPC»
	Supported by supply unit:	«HMV»			

The current measurement in the drive controller is adjusted in operation. The adjust values are checked for compliance with the allowed tolerance. If the values are higher the error message F2077 is generated.

Cause	Remedy
Hardware of control section or power section defective.	Replace power section or control section resp. entire drive controller.

 Only Rexroth service engineers or especially trained users are allowed to replace the control section or the power section. The replacement of the entire drive controller is described in the Project Planning Manual for the power section.

F2077 - Attributes Display: F2077
 Ident N°: F2077

Error Messages

8.7.54 F2086 Error supply module

Allocation	Contained in 02VRS:	«MPB»	«MPH»	«MPD»	
	Contained in 03VRS:	«MPB»	«MPH»	«MPD»	
	Contained in 04VRS:	«MPB»	«MPH»	«MPD»	
	Contained in 05VRS:	«MPB»	«MPH»	«MPD»	
	Contained in 06VRS:	«MPB»	«MPH»	«MPD»	«MPC»
	Contained in 07VRS:	«MPB»	«MPH»	«MPD»	«MPC»
	Contained in 08VRS:	«MPB»	«MPH»	«MPD»	«MPC»
	Supported by supply unit:	«-»			

This error is signaled by the supply to the drives via the module bus. It has high priority and...

- causes error reaction in the drives in operation. The error message is displayed at these drives.
- causes power of the supply unit to be switched off or the Bb contact of converters to open (requires assignment of respective bit "P-0-0861, Status word of power section" to digital output!) and possibly causes DC bus short circuit (requires corresponding wiring!).

This error can also have been caused by a fatal drive error that was signaled to the supply via the module bus. The respective settings must be made in "P-0-0118, Power supply, configuration".

Cause	Remedy
Failure in power supply or overload of power supply.	Check power supply
Fatal error message of one or several drives of a drive system and message signaled to supply (configuration P-0-0118).	Identify drive or drives signaling a fatal error. Remove cause of error at respective drive or drives.

See also Functional Description of firmware " Power Supply".

F2086 - Attributes	Display:	F2086
	Ident N°:	F2086

8.7.55 F2087 Module group communication error

Allocation	Contained in 02VRS:	«MPB»	«MPH»	«MPD»	
	Contained in 03VRS:	«MPB»	«MPH»	«MPD»	
	Contained in 04VRS:	«MPB»	«MPH»	«MPD»	
	Contained in 05VRS:	«MPB»	«MPH»	«MPD»	
	Contained in 06VRS:	«MPB»	«MPH»	«MPD»	«MPC»
	Contained in 07VRS:	«MPB»	«MPH»	«MPD»	«MPC»
	Contained in 08VRS:	«MPB»	«MPH»	«MPD»	«MPC»
	Supported by supply unit:	«HMV»			

The signal states of the module bus are incorrect.



The error can only be cleared, when the signals are error-free or the module bus communication was switched off.

Cause	Remedy
Failure of control voltage supply of a module bus node while "drive system" is ready for power output or in operation	Supply all devices of a "drive system" with control voltage
Disturbance on module bus	Identify and remove sources of disturbance
Incorrect signal timing on module bus	Identify and replace faulty device
Module bus cable defective	Identify and replace defective module bus cable; replace device, if necessary

Error Messages

8.7.58 F2102 It was impossible to address I²C memory

Allocation	Contained in 02VRS:	«MPB»	«MPH»	«MPD»	
	Contained in 03VRS:	«MPB»	«MPH»	«MPD»	
	Contained in 04VRS:	«MPB»	«MPH»	«MPD»	
	Contained in 05VRS:	«MPB»	«MPH»	«MPD»	
	Contained in 06VRS:	«MPB»	«MPH»	«MPD»	«MPC»
	Contained in 07VRS:	«MPB»	«MPH»	«MPD»	«MPC»
	Contained in 08VRS:	«MPB»	«MPH»	«MPD»	«MPC»
	Supported by supply unit:	«-»			

When addressing a memory via the I²C bus an error occurred.

Cause	Remedy
Failure occurs sporadically (firmware error)	Clear error and contact our service department in order to get a firmware update.
Encoder cable defective or bad shielding	Clear error. Replace defective encoder cable or improve shielding.
Encoder memory or encoder electronics is defective.	Clear error. Replace encoder or motor
Hardware defect on control section	Replace control section or entire drive controller



Only Rexroth service engineers or especially trained users are allowed to replace the control section. The replacement of the entire drive controller is described in the Project Planning Manual for the power section.

See also Functional Description of firmware "Measuring Systems"

F2102 - Attributes	Display:	F2102
	Ident N°:	F2102

8.7.59 F2103 It was impossible to address EnDat memory

Allocation	Contained in 02VRS:	«MPB»	«MPH»	«MPD»	
	Contained in 03VRS:	«MPB»	«MPH»	«MPD»	
	Contained in 04VRS:	«MPB»	«MPH»	«MPD»	
	Contained in 05VRS:	«MPB»	«MPH»	«MPD»	
	Contained in 06VRS:	«MPB»	«MPH»	«MPD»	«MPC»
	Contained in 07VRS:	«MPB»	«MPH»	«MPD»	«MPC»
	Contained in 08VRS:	«MPB»	«MPH»	«MPD»	«MPC»
	Supported by supply unit:	«-»			

When addressing a memory via the EnDat bus an error occurred.

Cause	Remedy
Failure occurs sporadically (firmware error)	Clear error and contact our service department in order to get a firmware update.
Encoder cable defective or bad shielding	Clear error. Replace defective encoder cable or improve shielding.
Encoder memory or encoder electronics is defective	Clear error. Replace encoder or motor.
Hardware defect on control section	Replace control section or entire drive controller.



Only Rexroth service engineers or especially trained users are allowed to replace the control section. The replacement of the entire drive controller is described in the Project Planning Manual for the power section.

See also Functional Description of firmware " Measuring Systems".

F2103 - Attributes **Display:** F2103
 Ident N°: F2103

8.7.60 F2104 Commutation offset invalid

Allocation	Contained in 02VRS:	«MPB»	«MPH»	«MPD»	
	Contained in 03VRS:	«MPB»	«MPH»	«MPD»	
	Contained in 04VRS:	«MPB»	«MPH»	«MPD»	
	Contained in 05VRS:	«MPB»	«MPH»	«MPD»	
	Contained in 06VRS:	«MPB»	«MPH»	«MPD»	«MPC»
	Contained in 07VRS:	«MPB»	«MPH»	«MPD»	«MPC»
	Contained in 08VRS:	«MPB»	«MPH»	«MPD»	«MPC»
	Supported by supply unit:	«-»			

The commutation offset value stored in the motor encoder memory was detected to be invalid.



The motor mustn't be operated without valid commutation offset!

Cause	Remedy
Failure occurs sporadically (firmware error)	Clear error. Then execute command "P-0-0524, C1200 Commutation offset setting command"; if error occurs again contact our service department in order to get a firmware update.
Encoder memory or encoder electronics is defective	Clear error. Replace encoder or motor. Then execute command "P-0-0524, C1200 Commutation offset setting command".

See also Functional Description of firmware " Commutation Setting".

F2104 - Attributes **Display:** F2104
 Ident N°: F2104

8.7.61 F2105 It was impossible to address Hiperface memory

Allocation	Contained in 02VRS:	«-»	«-»	«-»	
	Contained in 03VRS:	«MPB»	«MPH»	«MPD»	
	Contained in 04VRS:	«MPB»	«MPH»	«MPD»	
	Contained in 05VRS:	«MPB»	«MPH»	«MPD»	
	Contained in 06VRS:	«MPB»	«MPH»	«MPD»	«MPC»
	Contained in 07VRS:	«MPB»	«MPH»	«MPD»	«MPC»
	Contained in 08VRS:	«MPB»	«MPH»	«MPD»	«MPC»
	Supported by supply unit:	«-»			

When addressing a memory via the HIPERFACE bus an error occurred.

Cause	Remedy
Failure occurs sporadically (firmware error)	Clear error and contact our service department in order to get a firmware update.
Encoder cable defective or bad shielding	Clear error. Replace defective encoder cable or improve shielding.
Encoder memory or encoder electronics is defective	Clear error. Replace encoder or motor.
Hardware defect on control section	Replace control section or entire drive controller.

Error Messages



Only Rexroth service engineers or especially trained users are allowed to replace the control section. The replacement of the entire drive controller is described in the Project Planning Manual of the power section, the saving and loading of the parameters is explained in the Functional Description of the firmware.

See also Functional Description of firmware " Measuring Systems".

F2105 - Attributes
 Display: F2105
 Ident N°: F2105

8.7.62 F2110 Error in non-cyclical data communic. of power section

Allocation	Contained in 02VRS:	«MPB»	«MPH»	«MPD»	
	Contained in 03VRS:	«MPB»	«MPH»	«MPD»	
	Contained in 04VRS:	«MPB»	«MPH»	«MPD»	
	Contained in 05VRS:	«MPB»	«MPH»	«MPD»	
	Contained in 06VRS:	«MPB»	«MPH»	«MPD»	«MPC»
	Contained in 07VRS:	«MPB»	«MPH»	«MPD»	«MPC»
	Contained in 08VRS:	«MPB»	«MPH»	«MPD»	«MPC»
	Supported by supply unit:	«HMV»			

An error occurred in the communication between control section and power section.

Cause	Remedy
Failure occurs sporadically (firmware error)	Clear error and contact our service department for firmware update
Hardware defective	Should error occur repeatedly, control section or entire device has to be replaced



Only Rexroth service engineers or especially trained users are allowed to replace the control section. The replacement of the entire drive controller is described in the Project Planning Manual for the power section.

F2110 - Attributes
 Display: F2110
 Ident N°: F2110

8.7.63 F2120 MMC: Defective or missing, replace

Allocation	Contained in 02VRS:	«-»	«-»	«-»	
	Contained in 03VRS:	«-»	«-»	«-»	
	Contained in 04VRS:	«MPB»	«MPH»	«MPD»	
	Contained in 05VRS:	«MPB»	«MPH»	«MPD»	
	Contained in 06VRS:	«MPB»	«MPH»	«MPD»	«MPC»
	Contained in 07VRS:	«MPB»	«MPH»	«MPD»	«MPC»
	Contained in 08VRS:	«MPB»	«MPH»	«MPD»	«MPC»
	Supported by supply unit:	«-»			

Due to the setting in "P-0-4070, Parameter storage configuration" or due to the drive (a distributed servo drive KSM¹⁾ is used), it is necessary to have an MMC. The MMC is checked during the initialization phase; an error occurred during the check.

The drive only runs up to communication phase 2 and refuses further phase progression.

1) Component of the drive system Rexroth IndraDrive Mi

Error Messages

Communication via the SERCOS interface, however, and thereby the reading of the error message are ensured.

Cause	Remedy
In "Firmware" folder, operation firmware (file with extension ".ibf") is missing or more than on file with extension ".ibf" was found	Check and correct MMC and "Firmware" folder with appropriate reader
Operation firmware is defective Note: Writing the MMC takes a relatively long time. If you do not wait until end of writing process, file with operation firmware on MMC is not complete and it will be detected as being defective. Tip: For firmware update, it is necessary to replace file with extension ".ibf" (operation firmware); it is strongly recommended that you do not delete operation firmware, but re-name file extension, e.g. from ".ibf" to ".ibx". In any case, you should make a backup copy of current operation firmware.	Order firmware again; transmission error might possibly have occurred. Afterwards, copy firmware to MMC again. - or - Copy functioning operation firmware either from backup copy or from another MMC to defective MMC

F2122 - Attributes **Display:** F2122
 Ident N°: F2122

8.7.66 F2123 Retain data backup impossible

Allocation	Contained in 02VRS:	«-»	«-»	«-»	
	Contained in 03VRS:	«-»	«-»	«-»	
	Contained in 04VRS:	«MPB»	«MPH»	«MPD»	
	Contained in 05VRS:	«MPB»	«MPH»	«MPD»	
	Contained in 06VRS:	«MPB»	«MPH»	«MPD»	«MPC»
	Contained in 07VRS:	«MPB»	«MPH»	«MPD»	«MPC»
	Contained in 08VRS:	«MPB»	«MPH»	«MPD»	«MPC»
	Supported by supply unit:	«-»			

The distributed servo drive KSM (component of the drive system Rexroth IndraDrive Mi) is only ready for operation with the MMC having been plugged. The MMC is checked during the initialization phase.

In addition, important operating data, such as the current position, operating time, travel block etc., are stored when the controller is switched off. If this storing process is faulty, it is impossible to continue operation after the next switch-on in such a way as if there hadn't been any interruption; for example, the motor loses its reference in the case of faulty retain data backup. To make sure that the retain data backup works faultlessly, such a data backup is carried out for test purposes during the initialization phase.

The drive only runs up to communication phase 2 and refuses further phase progression.

Communication via the SERCOS interface, however, and thereby the reading of the error message are ensured.

Cause	Remedy
Backup of retain data for test purposes was terminated with an error	Hardware specifications of MMC used might possibly be so near to limits that this (quick) write access did not work. Replace MMC by original factory-provided one.
Temporary failure might possibly have occurred	Switch off and on again
Hardware or software defect	Read logbook and forward entry to service department

Error Messages

8.7.69 F2140 CCD slave error

Allocation	Contained in 02VRS:	«-»	«-»	«-»	
	Contained in 03VRS:	«-»	«-»	«-»	
	Contained in 04VRS:	«-»	«MPH»	«-»	
	Contained in 05VRS:	«-»	«MPH»	«-»	
	Contained in 06VRS:	«-»	«-»	«-»	«MPC»
	Contained in 07VRS:	«-»	«-»	«-»	«MPC»
	Contained in 08VRS:	«-»	«-»	«-»	«MPC»
	Supported by supply unit:	«-»			

An error occurred in a CCD slave.

Cause	Remedy
An F2 or F3 error occurred in a CCD slave and "error reaction active" has been set in "P-0-1600, CCD: configuration".	Locate faulty slave and remove cause of error for this slave.
An F8 error occurred in a CCD slave and "best possible deceleration" has been set in "P-0-1600, CCD: configuration" as reaction to an F8 error.	Locate faulty slave and remove cause of error for this slave.
Faulty command triggering of a remote axis (Axis2) in MLD-M master. (For example, motion function block "MC_MoveRelative" with "Acceleration"=0).	Locate faulty function block and remove error by means of function block error outputs.

See also Functional Description of firmware " Cross Communication (CCD)".

F2140 - Attributes	Display:	F2140
	Ident N°:	F2140

8.7.70 F2150 MLD motion function block error

Allocation	Contained in 02VRS:	«-»	«-»	«-»	
	Contained in 03VRS:	«-»	«-»	«-»	
	Contained in 04VRS:	«MPB»	«MPH»	«-»	
	Contained in 05VRS:	«MPB»	«MPH»	«-»	
	Contained in 06VRS:	«MPB»	«MPH»	«-»	«MPC»
	Contained in 07VRS:	«MPB»	«MPH»	«-»	«MPC»
	Contained in 08VRS:	«MPB»	«MPH»	«-»	«MPC»
	Supported by supply unit:	«-»			

During command triggering with a motion function block an error occurred.



The reaction to errors can be configured.



The error message F2150 is available as of firmware MPx04V10.

Cause	Remedy
Faulty command triggering in MLD-S (single-axis application) - or - Faulty command triggering of local axis (axis1) in MLD-M master. (For example, motion function block such as "MC_MoveRelative" with "Acceleration"=0).	Locate faulty function block and remove error by means of function block error outputs.

See also Application Manual Rexroth IndraMotion MLD " Error Handling of IndraMotion MLD".

F2150 - Attributes	Display:	F2150
	Ident N°:	F2150

8.7.71 F2174 Loss of motor encoder reference

Allocation	Contained in 02VRS:	«MPB»	«MPH»	«MPD»	
	Contained in 03VRS:	«MPB»	«MPH»	«MPD»	
	Contained in 04VRS:	«MPB»	«MPH»	«MPD»	
	Contained in 05VRS:	«MPB»	«MPH»	«MPD»	
	Contained in 06VRS:	«MPB»	«MPH»	«MPD»	«MPC»
	Contained in 07VRS:	«MPB»	«MPH»	«MPD»	«MPC»
	Contained in 08VRS:	«MPB»	«MPH»	«MPD»	«MPC»
	Supported by supply unit:	«-»			

In the case of absolute encoder evaluation, the validity of the initialized absolute position is checked during position initialization. If the controller detects that the position data reference of the encoder cannot be established any more due to changes of the mechanical system parameters or due to replacement of encoder or device, the actual position value status ("S-0-0403, Position feedback value status") goes to "relative" and the error F2174 is generated.

Cause	Remedy
Switching on without reference (in the case of initial commissioning or caused, for example, by changing parameters that characterize mechanical system or influence position evaluation).	Clear error and reestablish position data reference.
Switching on without reference (after replacing motor or motor encoder)	Clear error and establish position data reference.
Motor encoder defective	Replace motor or motor encoder, clear error and establish position data reference.
Parameters of mechanical system changed (gear, feed constant, ...)	Clear error and establish position data reference.
Amplifier replaced without parameter update	Clear error and establish position data reference
Switching on without reference after replacement of device with loaded axis-specific parameter values (according to list from "S-0-0192, IDN-list of backup operation data").	Clear error and establish position data reference - or - Clear error, then load parameter values of "P-0-0195, IDN list of retain data (replacement of devices)", if it was possible to save them immediately before device was replaced. Check reestablished position data reference for correctness.

F2174 - Attributes **Display:** F2174
 Ident N°: F2174

8.7.72 F2175 Loss of optional encoder reference

Allocation	Contained in 02VRS:	«MPB»	«MPH»	«MPD»	
	Contained in 03VRS:	«MPB»	«MPH»	«MPD»	
	Contained in 04VRS:	«MPB»	«MPH»	«MPD»	
	Contained in 05VRS:	«MPB»	«MPH»	«MPD»	
	Contained in 06VRS:	«MPB»	«MPH»	«MPD»	«MPC»
	Contained in 07VRS:	«MPB»	«MPH»	«MPD»	«MPC»
	Contained in 08VRS:	«MPB»	«MPH»	«MPD»	«MPC»
	Supported by supply unit:	«-»			

In the case of absolute encoder evaluation, the validity of the initialized absolute position is checked during position initialization. If the controller detects that the position data reference of the encoder cannot be established any more due to changes of the mechanical system parameters or due to replacement of encoder or device, the actual position value status ("S-0-0403,

Error Messages

Position feedback value status") goes to "relative" and the error F2175 is generated.

Cause	Remedy
Switching on without reference (in the case of initial commissioning or caused, for example, by changing parameters that characterize mechanical system or influence position evaluation).	Clear error and reestablish position data reference.
Switching on without reference (after replacement of encoder).	Clear error and establish position data reference.
Optional encoder defective.	Replace encoder, clear error and establish position data reference.
Parameters of mechanical system changed (gear, feed constant, ...).	Clear error and establish position data reference.
Amplifier replaced without parameter update.	Clear error and establish position data reference.
Switching on without reference after replacement of device with loaded axis-specific parameter values (according to list from "S-0-0192, IDN-list of backup operation data").	Clear error and establish position data reference - or - Clear error, then load parameter values of "P-0-0195, IDN list of retain data (replacement of devices)", if it was possible to save them immediately before device was replaced. Check reestablished position data reference for correctness.

F2175 - Attributes **Display:** F2175
Ident N°: F2175

8.7.73 F2176 Loss of measuring encoder reference

Allocation	Contained in 02VRS:	«MPB»	«MPH»	«MPD»	
	Contained in 03VRS:	«MPB»	«MPH»	«MPD»	
	Contained in 04VRS:	«MPB»	«MPH»	«MPD»	
	Contained in 05VRS:	«MPB»	«MPH»	«MPD»	
	Contained in 06VRS:	«MPB»	«MPH»	«MPD»	«MPC»
	Contained in 07VRS:	«MPB»	«MPH»	«MPD»	«MPC»
	Contained in 08VRS:	«MPB»	«MPH»	«MPD»	«MPC»
	Supported by supply unit:	«-»			

When the controller is switched on, it determines, in the case of absolute encoder evaluation, the initial position of the measuring system (position initialization) and checks its validity. If the controller detects that the position reference of the encoder cannot be established any more due to changes of the mechanical system parameters or due to replacement of encoder or device, the actual position value status ("S-0-0403, Position feedback value status") goes to "relative" and this diagnostic message is generated.

Cause	Remedy
Switching on without reference (in the case of initial commissioning or caused, for example, by changing parameters that characterize mechanical system or influence position evaluation).	Clear error and establish position data reference.
Encoder defective	Replace measuring encoder, clear error and establish position data reference.

Cause	Remedy
Switching on without reference (after replacement of measuring encoder).	Clear error and establish position data reference.
Controller replaced without parameter update.	Clear error and establish position data reference.

F2176 - Attributes Display: F2176
 Ident N°: F2176

8.7.74 F2177 Modulo limitation error of motor encoder

Allocation	Contained in 02VRS:	«MPB»	«MPH»	«MPD»	
	Contained in 03VRS:	«MPB»	«MPH»	«MPD»	
	Contained in 04VRS:	«MPB»	«MPH»	«MPD»	
	Contained in 05VRS:	«MPB»	«MPH»	«MPD»	
	Contained in 06VRS:	«MPB»	«MPH»	«MPD»	«MPC»
	Contained in 07VRS:	«MPB»	«MPH»	«MPD»	«MPC»
	Contained in 08VRS:	«MPB»	«MPH»	«MPD»	«MPC»
	Supported by supply unit:	«-»			

With active modulo scaling the drive limits its actual position values to the values parameterized in "S-0-0103, Modulo value", otherwise to the value parameterized in "S-0-0278, Maximum travel range". As these values possibly cannot be exactly displayed, the corresponding recalculation of the systematic errors in the case of position overflow takes place in the drive.



In the ideal case "S-0-0278, Maximum travel range" is set in such a way that the drive always is within the defined travel range and there is no overflow.

Cause	Remedy
"S-0-0103, Modulo value" or "S-0-0278, Maximum travel range" have been incorrectly parameterized and not adjusted to the application.	Check and, if necessary, correct "S-0-0103, Modulo value" or "S-0-0278, Maximum travel range".
Drive was moved as rapidly that recalculation no longer works correctly.	Reduce drive velocity at position overflow.

F2177 - Attributes Display: F2177
 Ident N°: F2177

8.7.75 F2178 Modulo limitation error of optional encoder

Allocation	Contained in 02VRS:	«MPB»	«MPH»	«MPD»	
	Contained in 03VRS:	«MPB»	«MPH»	«MPD»	
	Contained in 04VRS:	«MPB»	«MPH»	«MPD»	
	Contained in 05VRS:	«MPB»	«MPH»	«MPD»	
	Contained in 06VRS:	«MPB»	«MPH»	«MPD»	«MPC»
	Contained in 07VRS:	«MPB»	«MPH»	«MPD»	«MPC»
	Contained in 08VRS:	«MPB»	«MPH»	«MPD»	«MPC»
	Supported by supply unit:	«-»			

According to scaling, the drive limits the actual position values to the maximum travel range or to the modulo value. As these values possibly cannot be exactly displayed the corresponding recalculation of the errors takes place in the drive.

Error Messages

Cause	Remedy
Encoder speed was so high that recalculation no longer works correctly.	Reduce encoder speed - or - change "S-0-0103, Modulo value"

F2178 - Attributes Display: F2178
 Ident N°: F2178

8.7.76 F2179 Modulo limitation error of measuring encoder

Allocation	Contained in 02VRS:	«MPB»	«MPH»	«MPD»	
	Contained in 03VRS:	«MPB»	«MPH»	«MPD»	
	Contained in 04VRS:	«MPB»	«MPH»	«MPD»	
	Contained in 05VRS:	«MPB»	«MPH»	«MPD»	
	Contained in 06VRS:	«MPB»	«MPH»	«MPD»	«MPC»
	Contained in 07VRS:	«MPB»	«MPH»	«MPD»	«MPC»
	Contained in 08VRS:	«MPB»	«MPH»	«MPD»	«MPC»
	Supported by supply unit:	«-»			

With active modulo scaling the drive limits its actual position values to the values parameterized in "S-0-0103, Modulo value", otherwise to the value parameterized in "S-0-0278, Maximum travel range". As these values possibly cannot be exactly displayed, the corresponding recalculation of the systematic errors in the case of position overflow takes place in the drive.



In the ideal case "S-0-0278, Maximum travel range" is set in such a way that the drive always is within the defined travel range and there is no overflow.

Cause	Remedy
"S-0-0103, Modulo value" or "S-0-0278, Maximum travel range" have been incorrectly parameterized and not adjusted to the application.	Check and, if necessary, correct "S-0-0103, Modulo value" or "S-0-0278, Maximum travel range"
Drive was moved as rapidly that recalculation no longer works correctly.	Reduce drive velocity at position overflow.

F2179 - Attributes Display: F2179
 Ident N°: F2179

8.7.77 F2190 Incorrect Ethernet configuration

Allocation	Contained in 02VRS:	«-»	«-»	«-»	
	Contained in 03VRS:	«-»	«-»	«-»	
	Contained in 04VRS:	«-»	«MPH»	«-»	
	Contained in 05VRS:	«MPB»	«MPH»	«MPD»	
	Contained in 06VRS:	«MPB»	«MPH»	«MPD»	«MPC»
	Contained in 07VRS:	«MPB»	«MPH»	«MPD»	«MPC»
	Contained in 08VRS:	«MPB»	«MPH»	«MPD»	«MPC»
	Supported by supply unit:	«-»			

The parameterization of the Ethernet communication interfaces is checked when the drive is initialized. An error was detected during this check.

Error Messages

Cause	Remedy
Unallowed configuration of parameters for Ethernet communication (TCP/IP): IP address and gateway address are not in the same IP network - or - IP address and gateway address are identical	Set parameters for Ethernet communication (TCP/IP) to valid values: <ul style="list-style-type: none"> • P-0-1531, Engineering: IP address • P-0-1532, Engineering: Network mask • P-0-1533, Engineering: Gateway address As of MPx05VRS, in addition: <ul style="list-style-type: none"> • P-0-1641, CCD: IP address • P-0-1642, CCD: Network mask • P-0-1643, CCD: Gateway address • S-0-1020, Master comm. engineering over IP: IP address • S-0-1021, Master comm. engineering over IP: Network mask • S-0-1022, Master comm. engineering over IP: Gateway address As of MPx06VRS, in addition: <ul style="list-style-type: none"> • P-0-4089.00.13, Master communication: IP address • P-0-4089.0.14, Master communication: Network mask • P-0-4089.00.15, Master communication: Gateway address
Due to storage problems, internal configuration of IP stack was inadmissibly terminated	Due to a hardware problem, it is necessary to replace control section



Only Rexroth service engineers or especially trained users are allowed to replace the control section. The replacement of the entire drive controller is described in the Project Planning Manual for the power section.

F2190 - Attributes Display: F2190
 Ident N°: F2190

8.7.78 F2260 Command current limit shutoff

Allocation	Contained in 02VRS:	«-»	«-»	«-»	
	Contained in 03VRS:	«MPB»	«MPH»	«MPD»	
	Contained in 04VRS:	«-»	«-»	«-»	
	Contained in 05VRS:	«-»	«-»	«-»	
	Contained in 06VRS:	«-»	«-»	«-»	«-»
	Contained in 07VRS:	«-»	«-»	«-»	«-»
	Contained in 08VRS:	«-»	«-»	«-»	«-»
	Supported by supply unit:	«-»			

The drive first reacts with the warning "E8260 Torque/force command value limit active" to the triggering of the current command value limitation.

If the current limitation is active for more than 1.5 seconds, the drive reacts with a drive error, when this has been parameterized in "P-0-0556, Config word of axis controller".

Error Messages

Cause	Remedy
Error reaction to current limitation active	Check whether error reaction to current limitation is desired and, if necessary, deactivate error reaction to current limitation in "P-0-0556, Config word of axis controller"
Current limitation active	Remove cause of current limitation (see "E8260 Torque/force command value limit active")

F2260 - Attributes Display: F2260
 Ident N°: F2260

8.7.79 F2270 Analog input 1 or 2, wire break

Allocation	Contained in 02VRS:	«MPB»	«-»	«-»	
	Contained in 03VRS:	«MPB»	«-»	«-»	
	Contained in 04VRS:	«MPB»	«-»	«-»	
	Contained in 05VRS:	«MPB»	«-»	«-»	
	Contained in 06VRS:	«MPB»	«-»	«-»	«-»
	Contained in 07VRS:	«MPB»	«-»	«-»	«-»
	Contained in 08VRS:	«MPB»	«-»	«-»	«-»
	Supported by supply unit:		«-»		

Conditions under which this error is triggered:

- The wire break monitor was activated in "P-0-0218, Analog input, control parameter" (by the setting for the measuring range of the analog inputs) and
- a setting in "P-0-0218, Analog input, control parameter" causes an error to be generated when the input value has fallen below the input value at analog input 1 or 2 and
- the current/voltage value at analog input 1 or 2 is lower than the minimum value of the measuring range.



The value range of the voltage or current source that is connected to the analog input should be limited to the allowed value range of the analog input.

Cause	Remedy
Input value at analog input 1 or 2 is lower than minimum value of voltage measuring range (setting "voltage signals" in "P-0-0218, Analog input, control parameter").	Check wiring of analog input, reestablish contact to voltage source, if necessary - or - Check value range of voltage source.
Input value at analog input 1 or 2 is lower than minimum value of current measuring range (setting "current signals" in "P-0-0218, Analog input, control parameter").	Check wiring of analog input, reestablish contact to current source, if necessary - or - Check value range of current source.



This error message can only be displayed at a controller containing a CSB01.1N-FC-... (BASIC OPENLOOP) control section.

F2270 - Attributes Display: F2270
 Ident N°: F2270

8.7.80 F2802 PLL is not synchronized

Allocation	Contained in 02VRS:	«-»	«-»	«-»	
	Contained in 03VRS:	«-»	«-»	«-»	
	Contained in 04VRS:	«-»	«-»	«-»	
	Contained in 05VRS:	«-»	«-»	«-»	
	Contained in 06VRS:	«-»	«-»	«-»	«-»
	Contained in 07VRS:	«-»	«-»	«-»	«-»
	Contained in 08VRS:	«-»	«-»	«-»	«-»
	Supported by supply unit:	«HMV»			

Synchronization to the mains voltage is impossible.

Cause	Remedy
At least one phase is missing	Check and, if necessary, replace mains circuit breakers.
Mains voltage is too low	Measure mains voltage and compare it to allowed value range.
Mains frequency is outside of specified range	Measure mains frequency and compare it to allowed value range.

F2802 - Attributes Display:
 Ident N°: F2802

8.7.81 F2814 Undervoltage in mains

Allocation	Contained in 02VRS:	«-»	«-»	«-»	
	Contained in 03VRS:	«-»	«-»	«-»	
	Contained in 04VRS:	«-»	«-»	«-»	
	Contained in 05VRS:	«-»	«-»	«-»	
	Contained in 06VRS:	«-»	«-»	«-»	«-»
	Contained in 07VRS:	«-»	«-»	«-»	«-»
	Contained in 08VRS:	«-»	«-»	«-»	«-»
	Supported by supply unit:	«HMV»			

The crest value of the mains voltage has fallen below the allowed minimum value (connection voltage range see documentation for HMV01.1).

Cause	Remedy
Mains voltage below minimum value	Use matching transformer

See also Functional Description of firmware " Power Supply".

F2814 - Attributes Display:
 Ident N°: F2814

8.7.82 F2815 Overvoltage in mains

Allocation	Contained in 02VRS:	«-»	«-»	«-»	
	Contained in 03VRS:	«-»	«-»	«-»	
	Contained in 04VRS:	«-»	«-»	«-»	
	Contained in 05VRS:	«-»	«-»	«-»	
	Contained in 06VRS:	«-»	«-»	«-»	«-»
	Contained in 07VRS:	«-»	«-»	«-»	«-»
	Contained in 08VRS:	«-»	«-»	«-»	«-»
	Supported by supply unit:	«HMV»			

Cause	Remedy
Crest value of mains voltage has exceeded allowed maximum value (supply voltage range see documentation "Rexroth IndraDrive Supply Units and Power Sections")	Check mains voltage. If necessary, use matching transformer

Error Messages

F2815 - Attributes Display: F2815
Ident N°: F2815

8.7.83 F2816 Softstart fault power supply unit

Allocation	Contained in 02VRS:	«MPB»	«MPH»	«MPD»	
	Contained in 03VRS:	«MPB»	«MPH»	«MPD»	
	Contained in 04VRS:	«MPB»	«MPH»	«MPD»	
	Contained in 05VRS:	«MPB»	«MPH»	«MPD»	
	Contained in 06VRS:	«MPB»	«MPH»	«MPD»	«MPC»
	Contained in 07VRS:	«MPB»	«MPH»	«MPD»	«MPC»
	Contained in 08VRS:	«MPB»	«MPH»	«MPD»	«MPC»
	Supported by supply unit:	«HMV»			

During the soft start process (charging of DC bus capacitance) the DC bus voltage curve is monitored. Great deviations suggest a defect in the power section and are diagnosed with the error F2816.

Cause	Remedy
Short circuit in DC bus	Check DC bus wiring, remove if there is a short circuit.
Load on DC bus	Check DC bus wiring; if an external braking resistor has been incorrectly connected, connect it correctly.
Insulation error in DC bus	Check DC bus wiring; if wiring is alright, there can be an insulation error within device or other devices connected to DC bus. To find defective device take connected devices out of drive system step by step (remove wiring).
Final value of DC bus voltage is not reached within a maximum time.	Check whether there is defect at load externally connected to DC bus.
Inadmissible voltage fluctuations in supply mains. Mains voltage has inadmissibly dropped during soft start process.	Check mains voltage
HMV01, HMV02: thermal overload of soft start circuit.	Check number of ON-OFF cycles.
Device is defective	Replace device

F2816 - Attributes Display: F2816
Ident N°: F2816

8.7.84 F2817 Overvoltage in power section

Allocation	Contained in 02VRS:	«-»	«-»	«-»	
	Contained in 03VRS:	«-»	«-»	«-»	
	Contained in 04VRS:	«-»	«-»	«-»	
	Contained in 05VRS:	«-»	«-»	«-»	
	Contained in 06VRS:	«-»	«-»	«-»	«-»
	Contained in 07VRS:	«-»	«-»	«-»	«-»
	Contained in 08VRS:	«-»	«-»	«-»	«-»
	Supported by supply unit:	«HMV»			

When the warning E8025 is present for devices of the "HMV" type, the error "F2817 Overvoltage in power section" is generated after a certain length of time which depends on the hardware index of the device.

From the hardware indices listed below upwards, the error F2817 is generated **100 milliseconds** after the warning E8025 has been present:

- HMV02.1R-W0015: From hardware index A09 upwards
- HMV01.1R-W0018: From hardware index A43 upwards
- HMV01.1R-W0045: From hardware index A43 upwards
- HMV01.1R-W0065: From hardware index A43 upwards

- HMV01.1R-W0120: From hardware index A02 upwards
- HMV01.1E-W0030: From hardware index A33 upwards
- HMV01.1E-W0075: From hardware index A34 upwards
- HMV01.1E-W0120: From hardware index A36 upwards

For devices of the "HMV" type with **smaller hardware indices**, the error F2817 is generated **2 seconds** after the warning E8025 has occurred.

For supply units of the "HCS" type this error message does not exist.



From the mentioned hardware indices upwards, the error can only be reset by switching the device off, in order to call attention to possible application errors [e.g. "coasting" of a synchronous motor at high speed (field weakening range) with a DC bus braking resistor value inadmissibly high for the motor].

Cause	Remedy
See "E8025 Overvoltage in power section"	See "E8025 Overvoltage in power section"

F2817 - Attributes Display:
 Ident N°: F2817

8.7.85 F2818 Phase failure

Allocation	Contained in 02VRS:	«-»	«-»	«-»	
	Contained in 03VRS:	«-»	«-»	«-»	
	Contained in 04VRS:	«-»	«-»	«-»	
	Contained in 05VRS:	«-»	«-»	«-»	
	Contained in 06VRS:	«-»	«-»	«-»	«-»
	Contained in 07VRS:	«-»	«-»	«-»	«-»
	Contained in 08VRS:	«-»	«-»	«-»	«-»
	Supported by supply unit:	«HMV»			

A single-phase mains failure, which lasted for a longer time than the tolerated phase failure time, was detected for a supply unit of the HMV type.

Supply unit	Tolerated phase failure time
HMV01.1E	approx. 2 s
HMV01.1R, HMV02.1R	approx. 2 s

Fig. 8-2: Tolerated phase failure times

Cause	Remedy
No mains voltage available	Check mains voltage and mains connection
Mains circuit breaker defective	Replace mains circuit breaker
Incorrect wiring	Check and correct wiring

F2818 - Attributes Display:
 Ident N°: F2818

Error Messages

8.7.86 F2819 Mains failure

Allocation	Contained in 02VRS:	«MPB»	«MPH»	«MPD»	
	Contained in 03VRS:	«MPB»	«MPH»	«MPD»	
	Contained in 04VRS:	«MPB»	«MPH»	«MPD»	
	Contained in 05VRS:	«MPB»	«MPH»	«MPD»	
	Contained in 06VRS:	«MPB»	«MPH»	«MPD»	«MPC»
	Contained in 07VRS:	«MPB»	«MPH»	«MPD»	«MPC»
	Contained in 08VRS:	«MPB»	«MPH»	«MPD»	«MPC»
	Supported by supply unit:	«HMV»			

The mains has failed and the DC bus voltage has fallen below a threshold value.

HMV Supply Units

A mains failure, which lasted for a longer time than the tolerated mains failure time, was detected for a supply unit of the HMV type.

Supply unit	Tolerated mains failure time
HMV01.1E	approx. 750 ms
HMV01.1R	approx. 1000 ms
HMV02.1R	approx. 1000 ms

Fig. 8-3: Tolerated mains failure times



If the mains failure occurs at regenerative supply units during a regeneration process to the supply mains, the supply unit switches off immediately.

Cause	Remedy
Mains failure (permanent or temporary)	Search and remove cause of mains failure
Mains circuit breakers defective	Replace mains circuit breakers

See also Functional Description of firmware Power Supply.

F2819 - Attributes	Display:	F2819
	Ident N°:	F2819

8.7.87 F2820 Braking resistor overload

Allocation	Contained in 02VRS:	«MPB»	«MPH»	«MPD»	
	Contained in 03VRS:	«MPB»	«MPH»	«MPD»	
	Contained in 04VRS:	«MPB»	«MPH»	«MPD»	
	Contained in 05VRS:	«MPB»	«MPH»	«MPD»	
	Contained in 06VRS:	«MPB»	«MPH»	«MPD»	«MPC»
	Contained in 07VRS:	«MPB»	«MPH»	«MPD»	«MPC»
	Contained in 08VRS:	«MPB»	«MPH»	«MPD»	«MPC»
	Supported by supply unit:	«HMV»			

Power was switched off due to possible overload of the braking resistor.

If the DC bus voltage exceeds the current switch-on threshold of the braking resistor ("P-0-0833, Braking resistor threshold") as a result of regenerative operation of the drive, the braking resistor is switched on to limit the DC bus voltage. The load of the braking resistor is displayed in "P-0-0844, Braking resistor load". When the load rises to 110%, error F2820 is displayed.



Error F2820 also indicates that no braking resistor has been connected or that the connected braking resistor is defective. A value of at least 110% is displayed in "P-0-0844, Braking resistor load", although in reality there isn't any load present or possible!

Error Messages



After having eliminated the cause of the error, check the braking resistor for operability!

The error can only be cleared, when its cause has been removed.

Cause	Remedy
Allowed deceleration of connected drives too high	Reduce deceleration of connected drives
Energy absorption capacity of braking resistor is exhausted	Switch power supply off with a delay in the case of drive OFF or E-STOP (for regenerative supply units) or reduce velocity
Regenerated energy in machining cycle is too high	Increase cycle time or reduce maximum velocity
Continuous regenerative power and/or rotary drive energy is too high	Reduce maximum velocity or check dimensioning of braking resistor and, if necessary, increase dimensioning
Braking resistor is defective or has not been connected	For external braking resistor, visually check wiring and resistor component. If necessary, correct wiring or replace braking resistor. If internal braking resistor is defective, replace device.

See also Functional Description of firmware "Power Supply"

F2820 - Attributes **Display:** F2820
 Ident N°: F2820

8.7.88 F2821 Error in control of braking resistor

Allocation	Contained in 02VRS:	«MPB»	«MPH»	«MPD»	
	Contained in 03VRS:	«MPB»	«MPH»	«MPD»	
	Contained in 04VRS:	«MPB»	«MPH»	«MPD»	
	Contained in 05VRS:	«MPB»	«MPH»	«MPD»	
	Contained in 06VRS:	«MPB»	«MPH»	«MPD»	«MPC»
	Contained in 07VRS:	«MPB»	«MPH»	«MPD»	«MPC»
	Contained in 08VRS:	«MPB»	«MPH»	«MPD»	«MPC»
	Supported by supply unit:	«HMV»			



The error can occur for devices of both the HCS and the HMV type. There are different causes and remedies for both device types!

Devices of HCS Type An error has occurred in the control of the **external** braking resistor.

Cause	Remedy
Control of braking resistor has detected inadmissibly high current	Check braking resistor for correct resistance value. If necessary, use braking resistor with higher resistance value
Terminal connectors for external braking resistor have been short-circuited	Remove short circuit, connect braking resistor correctly, if necessary

Devices of HMV Type An error has occurred in the control of the **internal** braking resistor.

Cause	Remedy
Device is defective	Replace device

F2821 - Attributes **Display:** F2821
 Ident N°: F2821

Error Messages

8.7.89 F2825 Switch-on threshold braking resistor too low

Allocation	Contained in 02VRS:	«MPB»	«MPH»	«MPD»	
	Contained in 03VRS:	«MPB»	«MPH»	«MPD»	
	Contained in 04VRS:	«MPB»	«MPH»	«MPD»	
	Contained in 05VRS:	«MPB»	«MPH»	«MPD»	
	Contained in 06VRS:	«MPB»	«MPH»	«MPD»	«MPC»
	Contained in 07VRS:	«MPB»	«MPH»	«MPD»	«MPC»
	Contained in 08VRS:	«MPB»	«MPH»	«MPD»	«MPC»
	Supported by supply unit:	«-»			

For devices of type HCS, this error message is generated when the parameterized braking resistor reference switch-on voltage is too low. The braking resistor would already be active with correct DC bus voltage.

 The error can only be cleared, when its cause has been removed.

Cause	Remedy
This error message is generated for devices of type HCS when value of braking resistor reference switch-on voltage (list element 4 of "P-0-0858, Data of external braking resistor") activated via "P-0-0860, Converter configuration" is too low	Increase value of 4th list element in "P-0-0858, Data of external braking resistor" - or - Select different reference value for ON-OFF switching voltage of braking resistor in "P-0-0860, Converter configuration"

F2825 - Attributes Display: F2825
 Ident N°: F2825

8.7.90 F2833 Ground fault in motor line

Allocation	Contained in 02VRS:	«-»	«-»	«-»	
	Contained in 03VRS:	«-»	«-»	«-»	
	Contained in 04VRS:	«-»	«-»	«-»	
	Contained in 05VRS:	«-»	«-»	«-»	
	Contained in 06VRS:	«-»	«-»	«-»	«-»
	Contained in 07VRS:	«-»	«-»	«-»	«-»
	Contained in 08VRS:	«-»	«-»	«-»	«-»
	Supported by supply unit:	«HMV»			

During the loading process of the DC bus a ground fault was detected in the motor line of one of the connected converters/inverters.

Cause	Remedy
Ground fault in a motor line within drive system - or - Ground fault in a controller of drive system	Take controllers of drive system successively out of device group on control voltage and power voltage side, until error no longer occurs. By doing this identify faulty drive. Check insulation of motor cable with measuring device. If motor cable is not defective, there is a device or connection error.

F2833 - Attributes Display: F2833
 Ident N°: F2833

8.7.91 F2834 Contactor control error

Allocation	Contained in 02VRS:	«-»	«-»	«-»	
	Contained in 03VRS:	«-»	«-»	«-»	
	Contained in 04VRS:	«-»	«-»	«-»	
	Contained in 05VRS:	«-»	«-»	«-»	
	Contained in 06VRS:	«-»	«-»	«-»	«-»
	Contained in 07VRS:	«-»	«-»	«-»	«-»
	Contained in 08VRS:	«-»	«-»	«-»	«-»
	Supported by supply unit:	«HMV»			

The mains contactor couldn't be switched on or dropped out during operation.

Cause	Remedy
Due to wiring or control error, contact "ZKS" ["DC bus short circuit"] (X32.8) or contact "Netz AUS" ["mains OFF"] (X32.6/X32.7) was opened while contact "Netz EIN" ["mains ON"] (X32.4/X32.5) still had been close.	Check control. "Netz EIN" ("mains ON") has to be opened simultaneously with or before "ZKS" ("DC bus short circuit") and "Netz AUS" ("mains OFF").
Mains contactor could not be switched	Check wiring of interface. Check voltages at interfaces X32, X14 (HMV0x.xR) or at L1, L2 and L3 (HMV0x.xE).
Contactor control has detected an error	Replace device

F2834 - Attributes Display:
 Ident N°: F2834

8.7.92 F2835 Mains contactor wiring error

Allocation	Contained in 02VRS:	«-»	«-»	«-»	
	Contained in 03VRS:	«-»	«-»	«-»	
	Contained in 04VRS:	«-»	«-»	«-»	
	Contained in 05VRS:	«-»	«-»	«-»	
	Contained in 06VRS:	«-»	«-»	«-»	«-»
	Contained in 07VRS:	«-»	«-»	«-»	«-»
	Contained in 08VRS:	«-»	«-»	«-»	«-»
	Supported by supply unit:	«HMV»			

For supply units of the HMV01 line which do not have an internal mains contactor, an external mains contactor has to be controlled via X34.

Cause	Remedy
No external mains contactor connected	Connect mains contactor
No external switching voltage for mains contactor connected	Check mains contactor wiring
External mains contactor defective	Replace mains contactor
Pick-up delay of selected mains contactor too long	Use mains contactor with less pick-up delay

See also documentation "Rexroth IndraDrive Supply Units and Power Sections"

F2835 - Attributes Display:
 Ident N°: F2835

Error Messages

8.7.93 F2836 DC bus balancing monitor error

Allocation	Contained in 02VRS:	«MPB»	«MPH»	«MPD»	
	Contained in 03VRS:	«MPB»	«MPH»	«MPD»	
	Contained in 04VRS:	«MPB»	«MPH»	«MPD»	
	Contained in 05VRS:	«MPB»	«MPH»	«MPD»	
	Contained in 06VRS:	«MPB»	«MPH»	«MPD»	«MPC»
	Contained in 07VRS:	«MPB»	«MPH»	«MPD»	«MPC»
	Contained in 08VRS:	«MPB»	«MPH»	«MPD»	«MPC»
	Supported by supply unit:	«HVM»			

Unbalance on the DC bus was detected for the supply unit / converter.

Cause	Remedy
Unbalance on the DC bus	Switch device off/on; if error continues occurring, replace device

F2836 - Attributes Display: F2836
 Ident N°: F2836

8.7.94 F2837 Contactor monitoring error

Allocation	Contained in 02VRS:	«-»	«-»	«-»	
	Contained in 03VRS:	«-»	«-»	«-»	
	Contained in 04VRS:	«-»	«-»	«-»	
	Contained in 05VRS:	«-»	«-»	«-»	
	Contained in 06VRS:	«-»	«-»	«-»	«-»
	Contained in 07VRS:	«-»	«-»	«-»	«-»
	Contained in 08VRS:	«-»	«-»	«-»	«-»
	Supported by supply unit:	«HVM»			

The contactor monitor in the contactor control has detected an error.



When the diagnostic message occurs at a supply unit with external mains contactor (e.g. HVM01.1R-W0120), it is impossible to reset the error via the control panel, if the cause of the message is a sticking contact of the mains contactor or the conversion relay. In this case, you have to switch the 24V supply off and on again after the cause of the error was removed.

Cause	Remedy
Mains contactor could not be switched	Check voltages <ul style="list-style-type: none"> at interface X32, at X14 (HVM01.1R, HVM02.1R) or at L1-L3 (HVM01.1E)
Contactor monitor has detected an error	Replace device

F2837 - Attributes Display: F2837
 Ident N°: F2837

8.7.95 F2840 Error supply shutdown

Allocation	Contained in 02VRS:	«-»	«-»	«-»	
	Contained in 03VRS:	«-»	«-»	«-»	
	Contained in 04VRS:	«-»	«-»	«-»	
	Contained in 05VRS:	«-»	«-»	«-»	
	Contained in 06VRS:	«-»	«-»	«-»	«-»
	Contained in 07VRS:	«-»	«-»	«-»	«-»
	Contained in 08VRS:	«-»	«-»	«-»	«-»
	Supported by supply unit:	«HVM»			

Error Messages

A component in the drive system demands the shutdown of power supply. The supply unit switches power off and signals F2840.



The supply units (as of listed HWIs) generate the diagnostic message in the status "Bb", too. Prevent the activation of the mains contactor by means of the Bb1 contact (see "Control Circuits for the Mains Connection" in the Project Planning Manual of the drive system and "Connection Point X31" in the Project Planning Manual of HMV supply units).

Supply unit	Hardware index (HWI) (as per prototype phase MPx05)
HMV01.1E-W0030	A36
HMV01.1E-W0075	A37
HMV01.1E-W0120	A40
HMV01.1R-W0018	A48
HMV01.1R-W0045	A49
HMV01.1R-W0065	A50
HMV01.1R-W0120	A09
HMV02.1R-W0015	A14

Cause	Remedy
A second supply unit connected in parallel, a DC bus resistor unit or an inverter/converter signals an error in supply	Remove cause of error at respective supply unit, DC bus resistor unit or inverter/converter; then clear error

F2840 - Attributes Display: F2840
 Ident N°:

8.7.96 F2860 Overcurrent in mains-side power section

Allocation	Contained in 02VRS:	«-»	«-»	«-»	
	Contained in 03VRS:	«-»	«-»	«-»	
	Contained in 04VRS:	«-»	«-»	«-»	
	Contained in 05VRS:	«-»	«-»	«-»	
	Contained in 06VRS:	«-»	«-»	«-»	«-»
	Contained in 07VRS:	«-»	«-»	«-»	«-»
	Contained in 08VRS:	«-»	«-»	«-»	«-»
	Supported by supply unit:	«HMV»			

For HMV01.1R The current in the mains-side power bridge has exceeded the maximum allowed value. The power supply is switched off.

Cause	Remedy
Mains choke incorrectly connected	Check mains choke
Mains choke missing or incorrectly projected	Check mains choke
Mains filter missing or incorrectly projected	Check mains filter
Device defective	Replace device

F2860 - Attributes Display: F2860
 Ident N°:

Error Messages

8.7.97 F2890 Invalid device code

Allocation	Contained in 02VRS:	«-»	«-»	«-»	
	Contained in 03VRS:	«-»	«-»	«-»	
	Contained in 04VRS:	«-»	«-»	«-»	
	Contained in 05VRS:	«-»	«-»	«-»	
	Contained in 06VRS:	«-»	«-»	«-»	«-»
	Contained in 07VRS:	«-»	«-»	«-»	«-»
	Contained in 08VRS:	«-»	«-»	«-»	«-»
	Supported by supply unit:	«HVM»			

Cause	Remedy
Device defective	Replace device

F2890 - Attributes Display:
Ident N°: F2890

8.7.98 F2891 Incorrect interrupt timing

Allocation	Contained in 02VRS:	«-»	«-»	«-»	
	Contained in 03VRS:	«-»	«-»	«-»	
	Contained in 04VRS:	«-»	«-»	«-»	
	Contained in 05VRS:	«-»	«-»	«-»	
	Contained in 06VRS:	«-»	«-»	«-»	«-»
	Contained in 07VRS:	«-»	«-»	«-»	«-»
	Contained in 08VRS:	«-»	«-»	«-»	«-»
	Supported by supply unit:	«HVM»			

Cause	Remedy
Device defective	Replace device

F2891 - Attributes Display:
Ident N°: F2891

8.7.99 F2892 Hardware variant not supported

Allocation	Contained in 02VRS:	«-»	«-»	«-»	
	Contained in 03VRS:	«-»	«-»	«-»	
	Contained in 04VRS:	«-»	«-»	«-»	
	Contained in 05VRS:	«-»	«-»	«-»	
	Contained in 06VRS:	«-»	«-»	«-»	«-»
	Contained in 07VRS:	«-»	«-»	«-»	«-»
	Contained in 08VRS:	«-»	«-»	«-»	«-»
	Supported by supply unit:	«HVM»			

Cause	Remedy
Device defective	Replace device

F2892 - Attributes Display:
Ident N°: F2892

8.8 SERCOS Service Channel Error Codes / Error Messages of Serial Communication

For some errors concerning serial communication, the error codes defined in the SERCOS interface specification are used (see "SERCOS interface Specification", chapter 4.3.2.3 "Service channel error messages"). These codes are also used in the case of incorrect access to control and system parameters.

Error Messages

Error code		
Hexadecimal	Decimal	Explanation
0x1001	4097	No IDN
0x1009	4105	Invalid access to element 1
0x2001	8193	No name
0x2002	8194	Name transmission too short
0x2003	8195	Name transmission too long
0x2004	8196	Name cannot be changed (read only)
0x2005	8197	Name is write-protected at this time
0x3002	12290	Attribute transmission too short
0x3003	12291	Attribute transmission too long
0x3004	12292	Attribute cannot be changed (read only)
0x3005	12293	Attribute is write-protected at this time
0x4001	16385	No units
0x4002	16386	Unit transmission too short
0x4003	16387	Unit transmission too long
0x4004	16388	Unit cannot be changed (read only)
0x4005	16389	Unit is write-protected at this time
0x5001	20481	No minimum input value
0x5002	20482	Minimum input value transmission too short
0x5003	20483	Minimum input value transmission too long
0x5004	20484	Minimum input value cannot be changed (read only)
0x5005	20485	Minimum input value is write-protected at this time
0x6001	24577	No maximum input value
0x6002	24578	Maximum input value transmission too short
0x6003	24579	Maximum input value transmission too long
0x6004	24580	Maximum input value cannot be changed (read only)
0x6005	24581	Maximum input value is write-protected at this time
0x7002	28674	Operation data transmission too short
0x7003	28675	Operation data transmission too long
0x7004	28676	Operation data cannot be changed (read only)
0x7005	28677	Operation data is write-protected at this time (reason: communication phase or mode)
0x7006	28678	Operation data is smaller than the minimum input value
0x7007	28679	Operation data is greater than the maximum input value
0x7008	28680	Invalid operation data (e.g. IDN not supported, invalid bit number, invalid bit combination, invalid list length)
0x7009	28681	Operation data write protected by a password

Error Messages

Error code		
Hexadecimal	Decimal	Explanation
0x700A	28682	Operation data is write protected, it is configured cyclically (IDN is configured in the MDT or AT. Therefore writing via the service channel is not allowed).
0x700B	28683	Invalid indirect addressing (e.g., data container, list handling)
0x700C	28684	Operation data is write protected, due to other settings (e.g., parameter, operation mode, drive enable, drive on etc.)
0x7010	28688	Procedure command already active
0x7011	28689	Procedure command not interruptible
0x7012	28690	Procedure command at this time not executable (e.g., in this phase the procedure command cannot be activated)
0x7013	28691	Procedure command not executable (invalid or false parameters)

Fig. 8-4: SERCOS Error Codes

9 Warnings (Exxxx)

9.1 Fatal Warnings (E8xxx)

9.1.1 Behavior in the Case of Fatal Warnings

There are different drive reactions in the case of warnings of **category E8xxx**; they are described under the cause/remedy descriptions of the warnings.

9.1.2 E8025 Overvoltage in power section

Allocation	Contained in 02VRS:	«MPB»	«MPH»	«MPD»	
	Contained in 03VRS:	«MPB»	«MPH»	«MPD»	
	Contained in 04VRS:	«MPB»	«MPH»	«MPD»	
	Contained in 05VRS:	«MPB»	«MPH»	«MPD»	
	Contained in 06VRS:	«MPB»	«MPH»	«MPD»	«MPC»
	Contained in 07VRS:	«MPB»	«MPH»	«MPD»	«MPC»
	Contained in 08VRS:	«MPB»	«MPH»	«MPD»	«MPC»
	Supported by supply unit:	«HMV»			

The DC bus voltage is monitored. When the allowed maximum value (870 V) is exceeded, the fatal warning E8025 is generated.

The controller switches the motor to torque-free state in the case of overvoltage. If the DC bus voltage falls below the allowed maximum value again, the motor is switched on again.

Cause	Remedy
Energy regenerated to DC bus by mechanical machine system during braking process was so high that supply unit couldn't dissipate it during regeneration time. This caused DC bus voltage to rise to inadmissible value	Reduce regenerative power by lower acceleration values – or – Correct dimensioning of drive – or – Sufficiently dimension supply unit as regards braking energy requirements; if necessary, use additional braking resistor if existing braking resistor has been under-dimensioned
Mains supply voltage (alternating input voltage) too high	Check mains supply voltage (alternating voltage/3-phase)
No braking resistor connected or connection or cable defective	Connect braking resistor or check connection
F8xxx error at high speed (field weakening range) of a synchronous motor	Check whether braking resistance value in DC bus exceeds maximum value allowed for motor; if necessary, reduce braking resistance value to or below allowed value

Warnings (Exxxx)



Only for HMV: When the warning E8025 is present, the error "F2817 Overvoltage in power section" is generated after a certain length of time which depends on the hardware index of the device.

From the **hardware indices** listed below **upwards**, the error F2817 is generated **100 milliseconds** after the warning E8025 has been present:

- HMV02.1R-W0015: From hardware index A09 upwards
- HMV01.1R-W0018: From hardware index A43 upwards
- HMV01.1R-W0045: From hardware index A43 upwards
- HMV01.1R-W0065: From hardware index A43 upwards
- HMV01.1R-W0120: From hardware index A02 upwards
- HMV01.1E-W0030: From hardware index A33 upwards
- HMV01.1E-W0075: From hardware index A34 upwards
- HMV01.1E-W0120: From hardware index A36 upwards

For devices of the "HMV" type with **smaller hardware indices**, the error F2817 is generated **2 seconds** after the warning E8025 has occurred.

E8025 - Attributes	Display:	E8025
	Ident N°:	E8025

9.1.3 E8026 Undervoltage in power section

Allocation	Contained in 02VRS:	«-»	«-»	«-»	
	Contained in 03VRS:	«-»	«-»	«-»	
	Contained in 04VRS:	«MPB»	«MPH»	«MPD»	
	Contained in 05VRS:	«MPB»	«MPH»	«MPD»	
	Contained in 06VRS:	«MPB»	«MPH»	«MPD»	«MPC»
	Contained in 07VRS:	«MPB»	«MPH»	«MPD»	«MPC»
	Contained in 08VRS:	«MPB»	«MPH»	«MPD»	«MPC»
	Supported by supply unit:	«HMV»			

The DC bus voltage value is monitored by the drive controller and the supply unit.

Drive Controllers HMS, HMD, HCS

If the DC bus voltage falls below the minimum value determined for the drive (see value of "P-0-0114, Undervoltage threshold") or it reacts to "DC bus not ok" of the module bus, the device generates the warning E8026 if "fatal warning" has been set with regard to the reaction to undervoltage in "P-0-0118, Power supply, configuration".



In the case of fatal warning E8026, the motive torque is locked. The control unit still can actively decelerate the drive, but no longer accelerate it.

Supply Units HMV, Identifier "FCN1" or "FNN1"



This diagnostic message is only displayed for HMV supply units which have the identifier "FCN1" or "FNN1" at the position "Other design" in the type code.

If the DC bus voltage falls below 75% of the mains voltage crest value that was detected when the mains contactor had been switched on, "error DC bus voltage, mains failure" is signaled via the module bus and E8026 is displayed at the device. Power is switched off!

Warnings (Exxxx)

According to the situation in the mains, the diagnostic message is only displayed for a short time.

Cause	Remedy
Power is switched off without previous drive deactivation by means of drive enable ("AF")	Check logic for activating drive in connected control unit
Malfunction or overload of power supply	Check power supply
Mains failure	Check cause of mains failure, switch mains voltage on again
Temporary supply unit overload	Reduce processing cycle of machine

See also Functional Description of firmware "Power Supply"

E8026 - Attributes Display: E8026
 Ident N°: E8026

9.1.4 E8027 Safe torque off while drive enabled

Allocation	Contained in 02VRS:	«-»	«-»	«-»	
	Contained in 03VRS:	«MPB»	«MPH»	«MPD»	
	Contained in 04VRS:	«MPB»	«MPH»	«MPD»	
	Contained in 05VRS:	«MPB»	«MPH»	«MPD»	
	Contained in 06VRS:	«MPB»	«MPH»	«MPD»	«MPC»
	Contained in 07VRS:	«MPB»	«MPH»	«MPD»	«MPC»
	Contained in 08VRS:	«MPB»	«MPH»	«MPD»	«MPC»
	Supported by supply unit:	«-»			



This diagnostic message only exists as of firmware versions MPx03V24 and MPx04V14.

Up to MPx06, the name of this diagnostic message was "E8027 Safety related standstill while drive enabled".

⚠ DANGER	Injury and property damage caused by uncontrolled axis motion!
-----------------	---

⇒ If warning E8027 occurs, the drive immediately goes torque-free.

Cause	Remedy
Starting lockout (up to MPx06) or "Safe torque off" (as of MPx07) was set with active drive enable and diagnostic message has been set to "fatal warning" via parameter P-0-0101	Remove drive enable

E8027 - Attributes Display: E8027
 Ident N°: E8027

9.1.5 E8028 Overcurrent in power section

Allocation	Contained in 02VRS:	«MPB»	«MPH»	«MPD»	
	Contained in 03VRS:	«MPB»	«MPH»	«MPD»	
	Contained in 04VRS:	«MPB»	«MPH»	«MPD»	
	Contained in 05VRS:	«MPB»	«MPH»	«MPD»	
	Contained in 06VRS:	«MPB»	«MPH»	«MPD»	«MPC»
	Contained in 07VRS:	«MPB»	«MPH»	«MPD»	«MPC»
	Contained in 08VRS:	«MPB»	«MPH»	«MPD»	«MPC»
	Supported by supply unit:	«-»			

The controller monitors the motor current (= controller output current) supplied by the power section.

Warnings (Exxxx)

- If the controller output current is higher than the 1.2-fold of "S-0-0110, Amplifier peak current"
- or -
- if the controller output current is higher than the product of "P-0-4013, Current limit value of demagnetization" and "S-0-0109, Motor peak current",

the output stage of the power section is locked until the controller output current has fallen to allowed values again; during this time the warning E8028 is output.

Cause	Remedy
Current loop incorrectly parameterized	Check current loop setting ("S-0-0106, Current loop proportional gain 1", "S-0-0107, Current loop integral action time 1") and, if necessary, correct it after having contacted our service department
In the case of Bosch Rexroth motors with encoder data memory (MHD, MKD, MKE), values for current loop parameterization do not correspond to values in encoder data memory	Check whether values in "S-0-0106, Current loop proportional gain 1" and "S-0-0107, Current loop integral action time 1" correspond to values in encoder data memory ("P-0-2106, Current loop proportional gain 1, encoder memory" and "P-0-2107, Current loop integral-action time 1, encoder memory") Note: Calculation of "S-0-0106, Current loop proportional gain 1" depends on "P-0-0001, Switching frequency of the power output stage" and "P-0-0556, Control word of axis controller"!
In the case of Rexroth motors without encoder data memory, values for current loop parameterization do not correspond to manufacturer-side specifications	Check whether values in "S-0-0106, Current loop proportional gain 1" and "S-0-0107, Current loop integral action time 1" correspond to manufacturer-side specifications (see Drive-Top)
In the case of third-party motors, output data for calculating parameter values are not correct	Check whether output data for calculating parameter values are correct

E8028 - Attributes

Display: E8028
Ident N°: E8028

9.1.6 E8029 Positive position limit exceeded

Allocation	Contained in 02VRS:	«MPB»	«MPH»	«MPD»	
	Contained in 03VRS:	«MPB»	«MPH»	«MPD»	
	Contained in 04VRS:	«MPB»	«MPH»	«MPD»	
	Contained in 05VRS:	«MPB»	«MPH»	«MPD»	
	Contained in 06VRS:	«MPB»	«MPH»	«MPD»	«MPC»
	Contained in 07VRS:	«MPB»	«MPH»	«MPD»	«MPC»
	Contained in 08VRS:	«MPB»	«MPH»	«MPD»	«MPC»
	Supported by supply unit:	«-»			

The drive provides a function for monitoring an allowed travel range by means of software limit switches that can be parameterized.



The travel range monitor has to be activated and parameterized via "S-0-0049, Positive position limit value", "S-0-0050, Negative position limit value" and "S-0-0055, Position polarities".

The drive reaction (fatal warning or error) in case the travel range is exceeded has to be parameterized in "P-0-0090, Travel range limit parameter".

Warnings (Exxxx)

Cause	Remedy
A command value was set for the drive that causes an axis position outside the positive travel range/position limit value	Set command value that leads back to the allowed travel range. Contact machine manufacturer in order to find out cause of incorrect command value
Positive travel range/position limit value incorrectly parameterized	Check and, if necessary, correct parameterization of "S-0-0049, Positive position limit value"



The "S-0-0057, Position window" parameter is used to realize a hysteresis function for evaluating the position limit values.

See also Functional Description of firmware "Position Limitation/Travel Range Limit Switch"

E8029 - Attributes
 Display: E8029
 Ident N°: E8029

9.1.7 E8030 Negative position limit exceeded

Allocation	Contained in 02VRS:	«MPB»	«MPH»	«MPD»	
	Contained in 03VRS:	«MPB»	«MPH»	«MPD»	
	Contained in 04VRS:	«MPB»	«MPH»	«MPD»	
	Contained in 05VRS:	«MPB»	«MPH»	«MPD»	
	Contained in 06VRS:	«MPB»	«MPH»	«MPD»	«MPC»
	Contained in 07VRS:	«MPB»	«MPH»	«MPD»	«MPC»
	Contained in 08VRS:	«MPB»	«MPH»	«MPD»	«MPC»
	Supported by supply unit:	«-»			

The drive provides a function for monitoring an allowed travel range by means of software limit switches that can be parameterized.



The travel range monitor has to be activated and parameterized via "S-0-0049, Positive position limit value", "S-0-0050, Negative position limit value" and "S-0-0055, Position polarities".

The drive reaction (fatal warning or error) in case the travel range is exceeded has to be parameterized in "P-0-0090, Travel range limit parameter".

Cause	Remedy
A command value was set for the drive that causes an axis position outside the negative travel range/position limit value	Set command value that leads back to the allowed travel range. Contact machine manufacturer in order to find out cause of incorrect command value
Positive travel range/position limit value incorrectly parameterized	Check and, if necessary, correct parameterization of "S-0-0050, Negative position limit value"



The "S-0-0057, Position window" parameter is used to realize a hysteresis function for evaluating the position limit values.

See also Functional Description of firmware "Position Limitation/Travel Range Limit Switch"

E8030 - Attributes
 Display: E8030
 Ident N°: E8030

Warnings (Exxxx)

9.1.8 E8034 Emergency-Stop activated

Allocation	Contained in 02VRS:	«MPB»	«MPH»	«MPD»	
	Contained in 03VRS:	«MPB»	«MPH»	«MPD»	
	Contained in 04VRS:	«MPB»	«MPH»	«MPD»	
	Contained in 05VRS:	«MPB»	«MPH»	«MPD»	
	Contained in 06VRS:	«MPB»	«MPH»	«MPD»	«MPC»
	Contained in 07VRS:	«MPB»	«MPH»	«MPD»	«MPC»
	Contained in 08VRS:	«MPB»	«MPH»	«MPD»	«MPC»
	Supported by supply unit:	«-»			

The drive provides a function for monitoring an E-Stop input (connection of an external hardware switch). This monitor has to be activated and parameterized via "P-0-0008, Activation E-Stop function".



When the warning E8034 occurs, the axis is decelerated in accordance with the configured "best possible deceleration" (P-0-0119, bit0 to 3) for switching off drive enable.

Cause	Remedy
E-Stop input was controlled (0 V at digital input)	Remove failure that caused E-Stop to be triggered and clarify cause of triggering
Incorrect parameterization of digital inputs and outputs on control section	Check configuration of digital inputs/outputs on control section and correct it, if necessary
E-Stop switch or cable connection defective or incorrectly wired	Check function and wiring of E-Stop switch
Control section or digital inputs on control section defective	Replace control section or entire drive controller



Only Rexroth service engineers or especially trained users are allowed to replace the control section. The replacement of the entire drive controller is described in the Project Planning Manual for the power section.

See also Functional Description of firmware "E-Stop Function"

See also Functional Description of firmware "Digital Inputs/Outputs"

See also Functional Description of firmware "Velocity Command Value Reset"

E8034 - Attributes	Display:	E8034
	Ident N°:	E8034

9.1.9 E8040 Torque/force actual value limit active

Allocation	Contained in 02VRS:	«MPB»	«MPH»	«MPD»	
	Contained in 03VRS:	«MPB»	«MPH»	«MPD»	
	Contained in 04VRS:	«MPB»	«MPH»	«MPD»	
	Contained in 05VRS:	«MPB»	«MPH»	«MPD»	
	Contained in 06VRS:	«MPB»	«MPH»	«MPD»	«MPC»
	Contained in 07VRS:	«MPB»	«MPH»	«MPD»	«MPC»
	Contained in 08VRS:	«MPB»	«MPH»	«MPD»	«MPC»
	Supported by supply unit:	«-»			

The warning E8040 is generated when the "stall protection loop" takes effect and changes the working point of the machine for its relief.

Warnings (Exxxx)

Cause	Remedy
Load torque is too high	Reduce load torque
Torque limit values incorrectly parameterized	Check parameters "S-0-0082, Torque/force limit value positive"; "S-0-0083, Torque/force limit value negative"; "S-0-0092, Bipolar torque/force limit value" and "P-0-0109, Torque/force peak limit" and increase limits, if necessary

See also Functional Description of firmware "Voltage-Controlled Operation"

E8040 - Attributes Display: E8040
 Ident N°: E8040

9.1.10 E8041 Current limit active

Allocation	Contained in 02VRS:	«MPB»	«MPH»	«MPD»	
	Contained in 03VRS:	«MPB»	«MPH»	«MPD»	
	Contained in 04VRS:	«MPB»	«MPH»	«MPD»	
	Contained in 05VRS:	«MPB»	«MPH»	«MPD»	
	Contained in 06VRS:	«MPB»	«MPH»	«MPD»	«MPC»
	Contained in 07VRS:	«MPB»	«MPH»	«MPD»	«MPC»
	Contained in 08VRS:	«MPB»	«MPH»	«MPD»	«MPC»
	Supported by supply unit:	«-»			

The warning E8041 is generated when the current limitation loop takes effect and reduces the output voltage due to overvoltage.

Cause	Remedy
"S-0-0109, Motor peak current" incorrectly parameterized	Check content of "S-0-0109, Motor peak current" and increase it, if necessary
Short circuit at output of power output stage (e.g. in motor cable or in motor)	Check motor connection and motor for short circuit and replace cable or motor, if necessary
Power output stage in drive controller defective	Replace drive controller



The replacement of the drive controller is described in the Project Planning Manual for the power section.

See also Functional Description of firmware "Voltage-Controlled Operation"

E8041 - Attributes Display: E8041
 Ident N°: E8041

9.1.11 E8042 Both travel range limit switches activated

Allocation	Contained in 02VRS:	«MPB»	«MPH»	«MPD»	
	Contained in 03VRS:	«MPB»	«MPH»	«MPD»	
	Contained in 04VRS:	«MPB»	«MPH»	«MPD»	
	Contained in 05VRS:	«MPB»	«MPH»	«MPD»	
	Contained in 06VRS:	«MPB»	«MPH»	«MPD»	«MPC»
	Contained in 07VRS:	«MPB»	«MPH»	«MPD»	«MPC»
	Contained in 08VRS:	«MPB»	«MPH»	«MPD»	«MPC»
	Supported by supply unit:	«-»			

The compliance with the allowed travel range of linear axes is monitored on the hardware side via two travel range limit switches. When the travel range has been exceeded, one of the two limit switches is activated, if the limit switches were correctly mounted.

The warning E8042 is generated, if

- the controller detects that both travel range limit switches have been simultaneously activated and

Warnings (Exxxx)

- exceeding the travel range is handled as a fatal warning (setting in "P-0-0090, Travel range limit parameter").



As long as the cause of E8042 has not been removed, the controller does not accept any command value!

Cause	Remedy
Due to incorrect mounting, axis activates both travel range limit switches simultaneously	Mount travel range limit switches in such a way that they are activated shortly before axis end position is reached. Make sure the braking distance is sufficient
Travel range limit switches were incorrectly connected	Connect travel range limit switches correctly; check compliance with switching logic set in "P-0-0090, Travel range limit parameter"
Switching logic of travel range limit switches does not correspond to realized wiring	Check switching logic with regard to realized wiring, adjust it in "P-0-0090, Travel range limit parameter", if necessary

E8042 - Attributes Display: E8042
Ident N°: E8042

9.1.12 E8043 Positive travel range limit switch activated

Allocation	Contained in 02VRS:	«MPB»	«MPH»	«MPD»	
	Contained in 03VRS:	«MPB»	«MPH»	«MPD»	
	Contained in 04VRS:	«MPB»	«MPH»	«MPD»	
	Contained in 05VRS:	«MPB»	«MPH»	«MPD»	
	Contained in 06VRS:	«MPB»	«MPH»	«MPD»	«MPC»
	Contained in 07VRS:	«MPB»	«MPH»	«MPD»	«MPC»
	Contained in 08VRS:	«MPB»	«MPH»	«MPD»	«MPC»
	Supported by supply unit:	«-»			

The drive provides a function for monitoring travel range limit switches (external hardware limit switches). This monitor has to be activated and parameterized via "P-0-0090, Travel range limit parameter".



When the warning E8043 occurs, the axis is shut down with velocity command value reset.

Cause	Remedy
Travel range limit switch situated in positive direction (see Project Planning Manual for motor) was activated because axis is outside of travel range that was defined by means of travel range limit switches	Set drive enable and input a command value leading back to allowed travel range
Incorrect parameterization of digital inputs and outputs on control section	Correct configuration of digital inputs/outputs on control section and correct it, if necessary
Travel range limit switch or cable is defective or incorrectly wired	Check function and wiring of travel range limit switch
Control section or digital inputs on control section defective	Replace control section or entire drive controller



Only Rexroth service engineers or especially trained users are allowed to replace the control section. The replacement of the entire drive controller is described in the Project Planning Manual for the power section.

See also Functional Description of firmware "Travel Range Limits"

See also Functional Description of firmware "Digital Inputs/Outputs"

E8043 - Attributes **Display:** E8043
 Ident N°: E8043

9.1.13 E8044 Negative travel range limit switch activated

Allocation	Contained in 02VRS:	«MPB»	«MPH»	«MPD»	
	Contained in 03VRS:	«MPB»	«MPH»	«MPD»	
	Contained in 04VRS:	«MPB»	«MPH»	«MPD»	
	Contained in 05VRS:	«MPB»	«MPH»	«MPD»	
	Contained in 06VRS:	«MPB»	«MPH»	«MPD»	«MPC»
	Contained in 07VRS:	«MPB»	«MPH»	«MPD»	«MPC»
	Contained in 08VRS:	«MPB»	«MPH»	«MPD»	«MPC»
	Supported by supply unit:	«-»			

The drive provides a function for monitoring travel range limit switches (external hardware limit switches). This monitor has to be activated and parameterized via "P-0-0090, Travel range limit parameter".



When the warning E8044 occurs, the axis is shut down with velocity command value reset.

Cause	Remedy
Travel range limit switch situated in negative direction (see Project Planning Manual for motor) was activated because axis is outside of travel range that was defined by means of travel range limit switches	Set drive enable and input a command value leading back to allowed travel range
Incorrect parameterization of digital inputs and outputs on control section	Correct configuration of digital inputs/outputs on control section and correct it, if necessary
Travel range limit switch or cable is defective or incorrectly wired	Check function and wiring of travel range limit switch
Control section or digital inputs on control section defective	Replace control section or entire drive controller



Only Rexroth service engineers or especially trained users are allowed to replace the control section. The replacement of the entire drive controller is described in the Project Planning Manual for the power section.

See also Functional Description of firmware "Travel Range Limits"

See also Functional Description of firmware "Digital Inputs/Outputs"

E8044 - Attributes **Display:** E8044
 Ident N°: E8044

9.1.14 E8055 Motor overload, current limit active

Allocation	Contained in 02VRS:	«MPB»	«MPH»	«MPD»	
	Contained in 03VRS:	«MPB»	«MPH»	«MPD»	
	Contained in 04VRS:	«MPB»	«MPH»	«MPD»	
	Contained in 05VRS:	«MPB»	«MPH»	«MPD»	
	Contained in 06VRS:	«MPB»	«MPH»	«MPD»	«MPC»
	Contained in 07VRS:	«MPB»	«MPH»	«MPD»	«MPC»
	Contained in 08VRS:	«MPB»	«MPH»	«MPD»	«MPC»
	Supported by supply unit:	«-»			

In order to protect the motors against thermal destruction in the case of peak loads occurring for a very short time, the thermal work load of the motor is

Warnings (Exxxx)

continuously calculated in the controller by means of a motor temperature model.

If the maximum possible motor current is reduced, due to the current thermal motor load, compared to the content of "S-0-0109, Motor peak current", the drive generated the warning E8055. As a consequence thereof the drive can no longer follow the command values preset by a control unit.



When the E8055 warning is active, bit 0 (overload warning) is additionally set in "S-0-0012, Class 2 diagnostics".

Cause	Remedy
Too high acceleration torque/too high acceleration force demanded	Reduce acceleration by adjusted command value profile
Overload of drive by too high continuous load	Reduce overload in the case of long machining phases
Too high process or machining force (e.g. infeed)	Reduce process or machining force
Mechanical changes in axis (e.g. friction, load conditions,...)	Check mechanical system and, if necessary, optimize load conditions and/or friction conditions

See also Functional Description of firmware "Current Limitation

E8055 - Attributes Display: E8055
 Ident N°: E8055

9.1.15 E8057 Device overload, current limit active

Allocation	Contained in 02VRS:	«MPB»	«MPH»	«MPD»	
	Contained in 03VRS:	«MPB»	«MPH»	«MPD»	
	Contained in 04VRS:	«MPB»	«MPH»	«MPD»	
	Contained in 05VRS:	«MPB»	«MPH»	«MPD»	
	Contained in 06VRS:	«MPB»	«MPH»	«MPD»	«MPC»
	Contained in 07VRS:	«MPB»	«MPH»	«MPD»	«MPC»
	Contained in 08VRS:	«MPB»	«MPH»	«MPD»	«MPC»
	Supported by supply unit:	«HMV»			

In order to protect the devices against thermal destruction, the thermal load of the output stage in devices with digital current control is continuously calculated by a temperature model, depending on the measured current.

For HCS, HMS, HMD

If the thermal load exceeds 97% (displayed in "P-0-0141, Thermal drive load"), the continuous current limitation is activated and the warning E8057 is generated. As a consequence thereof the drive can no longer follow the command values preset by a control unit.



When the E8057 warning is active, bit 0 (overload warning) is additionally set in "S-0-0012, Class 2 diagnostics".

For HMV01.1R

When the thermal load has reached 100%, the continuous current limitation is activated and the warning E8057 is generated. As a consequence thereof the available DC bus power is reduced and especially drives that require high power can no longer follow the preset command values.

Cause	Remedy
Device is not adjusted to requirements of application or motor	Check dimensioning of drive and, if necessary, use more powerful device
Too high acceleration torque/too high acceleration force demanded	Reduce acceleration by adjusted command value profile

Warnings (Exxxx)

Cause	Remedy
Overload of drive by too high continuous load	Reduce overload in the case of long machining phases
Too high process or machining force (e.g. infeed)	Reduce process or machining force
Mechanical changes in axis (e.g. friction, load conditions,...)	Check mechanical system and, if necessary, optimize load conditions and/or friction conditions

See also Functional Description of firmware "Current Limitation"

E8057 - Attributes Display: E8057
 Ident N°: E8057

9.1.16 E8058 Drive system not ready for operation

Allocation	Contained in 02VRS:	«MPB»	«MPH»	«MPD»	
	Contained in 03VRS:	«MPB»	«MPH»	«MPD»	
	Contained in 04VRS:	«MPB»	«MPH»	«MPD»	
	Contained in 05VRS:	«MPB»	«MPH»	«MPD»	
	Contained in 06VRS:	«MPB»	«MPH»	«MPD»	«MPC»
	Contained in 07VRS:	«MPB»	«MPH»	«MPD»	«MPC»
	Contained in 08VRS:	«MPB»	«MPH»	«MPD»	«MPC»
	Supported by supply unit:	«-»			

This fatal warning can occur for drive controllers in operation that are interconnected via the module bus. If one of these drive controllers in operation signals an error via the module bus, the drives that are to react to signaled errors ("package reaction") react with shutdown. The reacting drives display the warning E8058, the supply unit displays "E2810 Drive system not ready for operation".

The settings for error messages and error reactions for devices that are interconnected via the DC bus and module bus are made in "P-0-0118, Power supply, configuration".

Cause	Remedy
Error message of one or several drives of a drive system	Identify drive or drives signaling an error. Remove cause of error at respective drive or drives

See also Functional Description of firmware "Power Supply"

E8058 - Attributes Display: E8058
 Ident N°: E8058

9.1.17 E8260 Torque/force command value limit active

Allocation	Contained in 02VRS:	«MPB»	«MPH»	«MPD»	
	Contained in 03VRS:	«MPB»	«MPH»	«MPD»	
	Contained in 04VRS:	«MPB»	«MPH»	«MPD»	
	Contained in 05VRS:	«MPB»	«MPH»	«MPD»	
	Contained in 06VRS:	«MPB»	«MPH»	«MPD»	«MPC»
	Contained in 07VRS:	«MPB»	«MPH»	«MPD»	«MPC»
	Contained in 08VRS:	«MPB»	«MPH»	«MPD»	«MPC»
	Supported by supply unit:	«-»			

Apart from the dynamic actual torque/force value limitation by means of a motor or amplifier temperature model, there are voltage-dependent (velocity-dependent), as well as parameterizable limitations of the torque/force command value. At least one of these limits has been reached.

Warnings (Exxxx)



As regards the occurrence of the warning E8260, there are different causes and remedies for "closed-loop operation" / "controlled motor operation" (FOC, FOCsl, FXC) and sensorless, voltage-controlled motor operation ("U/f-controlled motor operation" / "open-loop operation")!

Cause	Remedy
<p>"Controlled motor operation" / "closed-loop operation" Acceleration capacity of drive has been exceeded. In operating modes "position control" and "velocity control", this means that there is an ever-increasing position deviation (lag error) between command value and actual value</p>	<p>Reduce preset maximum acceleration value to allow drive to follow position or velocity command value characteristic</p>
<p>"Controlled motor operation" / "closed-loop operation" Velocity command value is higher than maximum velocity of drive. Drive limits output value of velocity loop (torque command value) so that output voltage of controller, depending on load, does not exceed value of "P-0-0535, Motor voltage at no load" or "P-0-0536, Maximum motor voltage"</p>	<p>Reduce maximum velocity command value in such a way that values of P-0-0535 or P-0-0536 are not reached when accelerating or at maximum velocity. If possible, use controlled supply unit (HMV-R); with uncontrolled supply unit increase supply voltage, if necessary</p>
<p>"Controlled motor operation" / "closed-loop operation" Torque/force limit values incorrectly set</p>	<p>Increase values of "S-0-0082, Torque/force limit value positive", "S-0-0083, Torque/force limit value negative", "S-0-0092, Bipolar torque/force limit value" and "P-0-0109, Torque/force peak limit", if necessary</p>
<p>"Controlled motor operation" / "closed-loop operation" Current loop incorrectly parameterized for motors without feedback data memory (e.g. kit motors or third-party motors)</p>	<p>Check contents of "S-0-0106, Current loop proportional gain 1" and "S-0-0107, Current loop integral action time 1" and correct them, if necessary. See also Functional Description of firmware "Automatic Setting of Motor Control "</p>
<p>"Controlled motor operation (FXC)" Controller cannot permanently provide required current at standstill of asynchronous motor</p>	<p>Reduce current at standstill ("P-0-0532, Premagnetization factor" * "P-0-4004, Magnetizing current") by lower value of P-0-0532 - or - Use controller with higher continuous current (type current)</p>
<p>"Open-loop operation" / "U/f-controlled motor operation" Acceleration capacity of controlled drive has been exceeded (velocity command value ramp too steep)</p>	<p>Maximum change of velocity with which drive can follow command values is determined by motor. This possibly requires adjustment of "P-0-0569, Maximum stator frequency change"</p>

E8260 - Attributes Display: E8260
 Ident N°: E8260

9.1.18 E8802 PLL is not synchronized

Allocation	Contained in 02VRS:	«-»	«-»	«-»	
	Contained in 03VRS:	«-»	«-»	«-»	
	Contained in 04VRS:	«-»	«-»	«-»	
	Contained in 05VRS:	«-»	«-»	«-»	
	Contained in 06VRS:	«-»	«-»	«-»	«-»
	Contained in 07VRS:	«-»	«-»	«-»	«-»
	Contained in 08VRS:	«-»	«-»	«-»	«-»
	Supported by supply unit:	«HMV»			

Warnings (Exxxx)



This diagnostic message is only displayed for HMV supply units which have the identifier "FCN1" or "FNN1" at the position "Other design" in the type code.

Synchronization with the mains voltage is impossible.

"Error DC bus voltage, mains failure" is signaled via the module bus and E8802 displayed at the device. Power is switched off!

According to the situation in the mains, the diagnostic message is only displayed for a short time.

Cause	Remedy
At least one phase is missing	Check mains circuit breakers and replace them, if necessary
Mains voltage is too low	Measure mains voltage and compare it to allowed range of values
Mains frequency is outside of specified range	Measure mains frequency and compare it to allowed range of values

See also documentation "Rexroth IndraDrive Supply Units and Power Sections"

E8802 - Attributes

Display:
 Ident N°: E8802

9.1.19 E8814 Undervoltage in mains

Allocation	Contained in 02VRS:	«-»	«-»	«-»	
	Contained in 03VRS:	«-»	«-»	«-»	
	Contained in 04VRS:	«-»	«-»	«-»	
	Contained in 05VRS:	«-»	«-»	«-»	
	Contained in 06VRS:	«-»	«-»	«-»	«-»
	Contained in 07VRS:	«-»	«-»	«-»	«-»
	Contained in 08VRS:	«-»	«-»	«-»	«-»
	Supported by supply unit:	«HMV»			



This diagnostic message is only displayed for HMV supply units which have the identifier "FCN1" or "FNN1" at the position "Other design" in the type code.

"Error DC bus voltage, mains failure" is signaled via the module bus and E8814 displayed at the device. Power is switched off!

According to the situation in the mains, the diagnostic message is only displayed for a short time.

Cause	Remedy
Crest value of mains voltage has fallen below allowed minimum value (supply voltage range see documentation "Rexroth IndraDrive Supply Units and Power Sections")	Use matching transformer

See also Functional Description of firmware "Power Supply"

E8814 - Attributes

Display:
 Ident N°: E8814

Warnings (Exxxx)

9.1.20 E8815 Overvoltage in mains

Allocation	Contained in 02VRS:	«-»	«-»	«-»	
	Contained in 03VRS:	«-»	«-»	«-»	
	Contained in 04VRS:	«-»	«-»	«-»	
	Contained in 05VRS:	«-»	«-»	«-»	
	Contained in 06VRS:	«-»	«-»	«-»	«-»
	Contained in 07VRS:	«-»	«-»	«-»	«-»
	Contained in 08VRS:	«-»	«-»	«-»	«-»
	Supported by supply unit:	«HMV»			



This diagnostic message is only displayed for HMV supply units which have the identifier "FCN1" or "FNN1" at the position "Other design" in the type code.

"Error DC bus voltage, mains failure" is signaled via the module bus and E8815 displayed at the device. Power is switched off!

According to the situation in the mains, the diagnostic message is only displayed for a short time.

Cause	Remedy
Crest value of mains voltage has exceeded allowed maximum value (supply voltage range see documentation "Rexroth IndraDrive Supply Units and Power Sections")	Check mains voltage. If necessary, use matching transformer

E8815 - Attributes Display:
 Ident N°: E8815

9.1.21 E8818 Phase failure

Allocation	Contained in 02VRS:	«-»	«-»	«-»	
	Contained in 03VRS:	«-»	«-»	«-»	
	Contained in 04VRS:	«-»	«-»	«-»	
	Contained in 05VRS:	«-»	«-»	«-»	
	Contained in 06VRS:	«-»	«-»	«-»	«-»
	Contained in 07VRS:	«-»	«-»	«-»	«-»
	Contained in 08VRS:	«-»	«-»	«-»	«-»
	Supported by supply unit:	«HMV»			



This diagnostic message is only displayed for HMV supply units which have the identifier "FCN1" or "FNN1" at the position "Other design" in the type code.

A single-phase mains failure, which lasted longer than the tolerated phase failure time, was detected for a supply unit of the HMV type.

"Error DC bus voltage, mains failure" is signaled via the module bus and E8818 displayed at the device. Power is switched off!

According to the situation in the mains, the diagnostic message is only displayed for a short time.

Supply unit	Tolerated phase failure time
HMV01.1E	Approx. 2s
HMV01.1R, HMV02.1R	Approx. 2s

Fig. 9-1: Tolerated Phase Failure Times

Warnings (Exxxx)

Cause	Remedy
No mains voltage available	Check mains voltage and mains connection
Mains circuit breaker defective	Replace mains circuit breaker
Incorrect wiring	Check and correct wiring

E8818 - Attributes Display: E8818
 Ident N°:

9.1.22 E8819 Mains failure

Allocation	Contained in 02VRS:	«-»	«-»	«-»	
	Contained in 03VRS:	«-»	«-»	«-»	
	Contained in 04VRS:	«MPB»	«MPH»	«MPD»	
	Contained in 05VRS:	«MPB»	«MPH»	«MPD»	
	Contained in 06VRS:	«MPB»	«MPH»	«MPD»	«MPC»
	Contained in 07VRS:	«MPB»	«MPH»	«MPD»	«MPC»
	Contained in 08VRS:	«MPB»	«MPH»	«MPD»	«MPC»
	Supported by supply unit:	«HMV»			

Drive Controllers HMS, HCS

Mains failure was detected. To maintain the DC bus, regenerative operation of the motor is still possible, motive operation of the motor is disabled. The function depends on "P-0-0118, Power supply, configuration" (behavior in case of undervoltage in DC bus).

Cause	Remedy
Power is switched off without previous drive deactivation by means of drive enable ("AF")	Check logic for activating drive in connected control unit
Malfunction or overload of power supply	Check power supply
Mains failure	Check cause of mains failure, switch mains voltage on again

Supply Units HMV, Identifier "FCN1" or "FNN1"



This diagnostic message is only displayed for HMV supply units which have the identifier "FCN1" or "FNN1" at the position "Other design" in the type code.

A mains failure lasting longer than the tolerated mains failure time was detected for a supply unit of type HMV.

"Error DC bus voltage, mains failure" is signaled via the module bus and E8819 displayed at the device. Power is switched off!

Sometimes, the diagnostic message is displayed only briefly, depending on the situation in the power supply network.

Supply unit	Tolerated mains failure time
HMV01.1E	Approx. 750 ms
HMV01.1R	Approx. 1000 ms
HMV02.1R	Approx. 1000 ms

Fig. 9-2: Tolerated Mains Failure Times



If the mains failure occurs at regenerative supply units during a regeneration process to the supply mains, the supply unit switches off immediately.

Warnings (Exxxx)

Cause	Remedy
Mains failure (permanent or temporary)	Search and remove cause of mains failure
Mains circuit breakers defective	Replace mains circuit breakers

See also Functional Description of firmware "Power Supply"

E8819 - Attributes
 Display: E8819
 Ident N°: E8819

9.2 Warnings of Category E4xxx

9.2.1 E4001 Double MST failure shutdown

Allocation	Contained in 02VRS:	«-»	«-»	«-»	
	Contained in 03VRS:	«-»	«-»	«-»	
	Contained in 04VRS:	«MPB»	«MPH»	«MPD»	
	Contained in 05VRS:	«MPB»	«MPH»	«MPD»	
	Contained in 06VRS:	«MPB»	«MPH»	«MPD»	«MPC»
	Contained in 07VRS:	«MPB»	«MPH»	«MPD»	«MPC»
	Contained in 08VRS:	«MPB»	«MPH»	«MPD»	«MPC»
	Supported by supply unit:	«-»			

Master Communication SERCOS II The master synchronization telegram (MST) was not received in the drive in two successive SERCOS cycles.

 In "P-0-4088, Master communication: Drive configuration", you can configure the reaction to the failure of the cyclic communication as a warning or as an error.

Cause	Remedy
Disturbance in fiber optic transmission line	Check all fiber optic cable connections in SERCOS ring and replace them, if necessary
Attenuation of light signals too high	Measure attenuation of fiber optic cables again. Maximum attenuation between T _x and R _x mustn't exceed 12.5 dB!
Different SERCOS cycle times in master and slave	Check SERCOS cycle times in master and slave and adjust them, if necessary
Disturbance in SERCOS interface (general)	Replace control section or entire drive

Master Communication SERCOS III The master synchronization telegram (MST) was not received in the drive in several successive SERCOS cycles. The number of allowed losses is set in S-0-1003.

 In "P-0-4088, Master communication: Drive configuration", you can configure the reaction to the failure of the cyclic communication as a warning or as an error.

Cause	Remedy
Different SERCOS cycle times in master and slave	Check SERCOS cycle times in master and slave and adjust them, if necessary
Disturbance in SERCOS interface (general)	Replace control section or entire drive

Warnings (Exxxx)

9.2.3 E4005 No command value input via master communication

Allocation	Contained in 02VRS:	«-»	«-»	«-»	
	Contained in 03VRS:	«-»	«-»	«-»	
	Contained in 04VRS:	«MPB»	«MPH»	«MPD»	
	Contained in 05VRS:	«MPB»	«MPH»	«MPD»	
	Contained in 06VRS:	«MPB»	«MPH»	«MPD»	«MPC»
	Contained in 07VRS:	«MPB»	«MPH»	«MPD»	«MPC»
	Contained in 08VRS:	«MPB»	«MPH»	«MPD»	«MPC»
	Supported by supply unit:	«-»			



In firmware version 04VRS, the name of the warning was "E4005 No data exchange possible via the field bus".

There is no command value input via the master communication interface.

⚠ DANGER Dangerous movements! Danger to life, risk of injury, serious injury or property damage by automatic restart after bus failure!

In the case of bus failure (message "F4009" or "E4005"), an error reaction must be carried out in the control unit, too, to prevent automatic restart after the bus has been reestablished. This means that the bits "Drive Halt", "drive enable" and "drive ON" (e.g. bits 13, 14 and 15 in parameter "P-0-4077, Field bus: Control word") should be reset in the control unit in the case of bus failure.

SERCOS The setting in parameter "P-0-4088, Master communication, configuration" is such that there won't be any drive error reaction initiated in case communication fails, but this warning will be displayed.

Cause	Remedy
See F4009	See F4009

Other Field Buses (CANopen, PROFIBUS, ...)

In "P-0-4088, Master communication, configuration", bus failure was configured as a warning.

Warning E4005 is generated in the following cases:

- No telegram with command values was received within the monitoring time stored in P-0-4075.
- or -
- The control unit was switched to "Stop".
- or -
- The control unit took the drive out of the master communication group.

Cause	Remedy
See F4009	See F4009

E4005 - Attributes Display: E4005
 Ident N°: E4005

9.2.4 E4006 Communication module overload

Allocation	Contained in 02VRS:	«-»	«-»	«-»	
	Contained in 03VRS:	«-»	«-»	«-»	
	Contained in 04VRS:	«-»	«-»	«-»	
	Contained in 05VRS:	«-»	«-»	«-»	
	Contained in 06VRS:	«-»	«-»	«-»	«-»
	Contained in 07VRS:	«-»	«-»	«-»	«-»
	Contained in 08VRS:	«MPB»	«MPH»	«MPD»	«MPC»
	Supported by supply unit:	«-»			

The communication module is overloaded.

Cause	Remedy
High network load	Check network configuration

E4006 - Attributes Display: E4006
 Ident N°: E4006

9.2.5 E4007 SERCOS III: Consumer connection failed

Allocation	Contained in 02VRS:	«-»	«-»	«-»	
	Contained in 03VRS:	«-»	«-»	«-»	
	Contained in 04VRS:	«-»	«-»	«-»	
	Contained in 05VRS:	«-»	«-»	«-»	
	Contained in 06VRS:	«MPB»	«MPH»	«MPD»	«MPC»
	Contained in 07VRS:	«MPB»	«MPH»	«MPD»	«MPC»
	Contained in 08VRS:	«MPB»	«MPH»	«MPD»	«MPC»
	Supported by supply unit:	«-»			

A consumer connection violates the selected monitoring criterion.

Cause	Remedy
Synchronous monitoring has been preset for a consumer connection and NewData bit of connection does not toggle in preset cycle	Producer of connection (can be bus master or another slave) does not work correctly
Too many telegrams fail due to disturbances	Check bus line and connector

E4007 - Attributes Display: E4007
 Ident N°: E4007

9.2.6 E4008 Invalid addressing command value data container A

Allocation	Contained in 02VRS:	«-»	«-»	«-»	
	Contained in 03VRS:	«MPB»	«MPH»	«MPD»	
	Contained in 04VRS:	«MPB»	«MPH»	«MPD»	
	Contained in 05VRS:	«MPB»	«MPH»	«MPD»	
	Contained in 06VRS:	«MPB»	«MPH»	«MPD»	«MPC»
	Contained in 07VRS:	«MPB»	«MPH»	«MPD»	«MPC»
	Contained in 08VRS:	«MPB»	«MPH»	«MPD»	«MPC»
	Supported by supply unit:	«-»			

During the index check in the multiplex channel an error occurred. During the cyclic data exchange the index for access to the lists **Data container A: configuration list command value-x** is monitored to find out whether it is pointing to a non-initialized position in the list.

Cause	Remedy
?	Check Data container A: configuration list command value-x
?	Check low byte of "S-0-0368, Data container A: addressing"

See also Functional Description of firmware "Multiplex Channel"

Warnings (Exxxx)

E4008 - Attributes **Display:** E4008
Ident N°: E4008

9.2.7 E4009 Invalid addressing actual value data container A

Allocation	Contained in 02VRS:	«-»	«-»	«-»	
	Contained in 03VRS:	«MPB»	«MPH»	«MPD»	
	Contained in 04VRS:	«MPB»	«MPH»	«MPD»	
	Contained in 05VRS:	«MPB»	«MPH»	«MPD»	
	Contained in 06VRS:	«MPB»	«MPH»	«MPD»	«MPC»
	Contained in 07VRS:	«MPB»	«MPH»	«MPD»	«MPC»
	Contained in 08VRS:	«MPB»	«MPH»	«MPD»	«MPC»
	Supported by supply unit:	«-»			

During the index check in the multiplex channel an error occurred. During the cyclic data exchange the index for access to the lists **Data container A: configuration list actual value-x** is monitored to find out whether it is pointing to a non-initialized position in the list.

Cause	Remedy
?	Check Data container A: configuration list actual value-x
?	Check high byte of "S-0-0368, Data container A: addressing"

See also Functional Description of firmware "Multiplex Channel"

E4009 - Attributes **Display:** E4009
Ident N°: E4009

9.2.8 E4010 Slave not scanned or address 0

Allocation	Contained in 02VRS:	«-»	«-»	«-»	
	Contained in 03VRS:	«-»	«-»	«-»	
	Contained in 04VRS:	«MPB»	«MPH»	«MPD»	
	Contained in 05VRS:	«MPB»	«MPH»	«MPD»	
	Contained in 06VRS:	«MPB»	«MPH»	«MPD»	«MPC»
	Contained in 07VRS:	«MPB»	«MPH»	«MPD»	«MPC»
	Contained in 08VRS:	«MPB»	«MPH»	«MPD»	«MPC»
	Supported by supply unit:	«-»			

During the initialization of the SERCOS ring in communication phase 1, the SERCOS master must address each slave which is to participate in the progression to higher phases. Slaves which are not addressed or for which drive address 0 has been set diagnose this by the warning E4010. Communication with these slaves in higher communication phases is impossible; they only work in repeater mode.

Cause	Remedy
Slave was not scanned in phase 1 or address 0 has been set	Set correct slave address
Slave deactivated by control unit	Check SERCOS master configuration

See also Functional Description of firmware "SERCOS interface"

E4010 - Attributes **Display:** E4010
Ident N°: E4010

9.2.9 E4011 Communication watchdog: Overload of cyclic communication

Allocation	Contained in 02VRS:	«-»	«-»	«-»
	Contained in 03VRS:	«-»	«-»	«-»
	Contained in 04VRS:	«-»	«-»	«-»
	Contained in 05VRS:	«-»	«-»	«-»
	Contained in 06VRS:	«MPB»	«MPH»	«MPD» «MPC»
	Contained in 07VRS:	«MPB»	«MPH»	«MPD» «MPC»
	Contained in 08VRS:	«MPB»	«MPH»	«MPD» «MPC»
	Supported by supply unit:	«-»		

Cause	Remedy
MultiEthernet interface is overloaded; I/O data of cyclic communication cannot be transmitted to drive	Please contact our service department

E4011 - Attributes Display: E4011
 Ident N°: E4011

9.2.10 E4012 Maximum number of CCD slaves exceeded

Allocation	Contained in 02VRS:	«-»	«-»	«-»
	Contained in 03VRS:	«-»	«-»	«-»
	Contained in 04VRS:	«-»	«MPH»	«-»
	Contained in 05VRS:	«-»	«MPH»	«-»
	Contained in 06VRS:	«-»	«-»	«-» «MPC»
	Contained in 07VRS:	«-»	«-»	«-» «MPC»
	Contained in 08VRS:	«-»	«-»	«-» «MPC»
	Supported by supply unit:	«-»		

When switching to communication phase 2, too many CCD slaves (→ **CCD**: Cross Communication Drives) were detected to have been connected to the cross communication interface of the CCD master.



This warning is always reset in phase 0.

Cause	Remedy
More CCD slaves than allowed have been connected to CCD master	Reduce number of connected CCD slaves Note: Maximum number of axes depends on CCD cycle time and data length

See also Functional Description of firmware "Cross Communication (CCD) "

E4012 - Attributes Display: E4012
 Ident N°: E4012

9.2.11 E4013 Incorrect CCD addressing

Allocation	Contained in 02VRS:	«-»	«-»	«-»
	Contained in 03VRS:	«-»	«-»	«-»
	Contained in 04VRS:	«-»	«MPH»	«-»
	Contained in 05VRS:	«-»	«MPH»	«-»
	Contained in 06VRS:	«-»	«-»	«-» «MPC»
	Contained in 07VRS:	«-»	«-»	«-» «MPC»
	Contained in 08VRS:	«-»	«-»	«-» «MPC»
	Supported by supply unit:	«-»		

When switching to communication phase 1, a projected CCD slave (→ **CCD**: Cross Communication Drives) could not be found.

Warnings (Exxxx)

Cause	Remedy
A CCD slave address has been used several times; actual topology (P-0-1603) and command topology (P-0-1636) do not match. Addresses must be unequivocal	Correct slave address in slave(s) ("P-0-4025, Drive address of master communication")
In "P-0-1601, CCD: Addresses of projected drives" - or - in "P-0-1604, CCD: addresses of projected I/Os" (only MPx05), a CCD slave was projected which does not exist in CCD group	Correct "P-0-1601, CCD: addresses of projected drives" according to connected CCD slaves Only MPx05: Correct "P-0-1604, CCD: addresses of projected I/Os" according to connected slaves - or - Assign addresses to slaves with P-0-1635
In "P-0-1601, CCD: Addresses of projected drives" - or - in "P-0-1604, CCD: addresses of projected I/Os" (only MPx05), a CCD slave was projected which has not been correctly connected	Connect all projected CCD slaves correctly

See also "P-0-1630, CCD: diagnosis"

See also Functional Description of firmware "Cross Communication (CCD) "

E4013 - AttributesDisplay: E4013
Ident N°: E4013**9.2.12 E4014 Incorrect phase switch of CCD slaves**

Allocation	Contained in 02VRS:	«-»	«-»	«-»	
	Contained in 03VRS:	«-»	«-»	«-»	
	Contained in 04VRS:	«-»	«MPH»	«-»	
	Contained in 05VRS:	«-»	«MPH»	«-»	
	Contained in 06VRS:	«-»	«-»	«-»	«MPC»
	Contained in 07VRS:	«-»	«-»	«-»	«MPC»
	Contained in 08VRS:	«-»	«-»	«-»	«MPC»
	Supported by supply unit:	«-»			

When the CCD group powers up to phase 0, 1 or 2, the CCD slaves are monitored for correct reaction. Warning E4014 is generated if the behavior of one or more slaves is not correct. There may be the following error symptoms:

- The CCD slave ignores phase switching and continues to transmit
- The CCD slave does not resume transmitting after completed phase switching
- The list of scanned CCD slaves is not stable (the list must be completely identical for phase 0)
- No communication on port 1 or port 2
- No scanned CCD slave (only if "P-0-1601, CCD: Addresses of projected drives" is also empty; otherwise E4013)
- The MST that was transmitted is not received correctly
- There is a connected CCD slave that is not supported by the CCD master

Warnings (Exxxx)

Cause	Remedy
SERCOS III plug connectors are loose or defective	Check SERCOS III plug connectors and replace if necessary
One of the CCD slaves is defective	Replace CCD slave

See also "P-0-1630, CCD: Diagnosis"

See also Functional Description of firmware "Cross Communication (CCD)"

E4014 - Attributes Display: E4014
 Ident N°: E4014

9.2.13 E4016 CCD: Topology error

Allocation	Contained in 02VRS:	«-»	«-»	«-»	
	Contained in 03VRS:	«-»	«-»	«-»	
	Contained in 04VRS:	«-»	«-»	«-»	
	Contained in 05VRS:	«-»	«-»	«-»	
	Contained in 06VRS:	«-»	«-»	«-»	«MPC»
	Contained in 07VRS:	«-»	«-»	«-»	«MPC»
	Contained in 08VRS:	«-»	«-»	«-»	«MPC»
	Supported by supply unit:	«-»			

The CCD master has detected in SERCOS phase 4 that the actual topology (P-0-1610.0.3) is different from the command topology (P-0-1620.0.3).



The command topology is only monitored if the value entered in "P-0-1620.0.3, CCD: Command topology" is unequal to "0".

Cause	Remedy
Command topology specified in P-0-1620.0.3 is not available	Change P-0-1620.0.3 according to setup of connections (topology) - or - Change connection(s) between slaves as parameterized in P-0-1620.0.3
Connection between two slaves interrupted	Check connection between slaves. NOTE: Green LED indicates link; parameter P-0-1610.0.21 displays addresses of slaves at end of line.

See also Functional Description of firmware "Cross Communication (CCD)"

E4016 - Attributes Display: E4016
 Ident N°: E4016

9.2.14 E4017 CCD: Unknown I/O configuration

Allocation	Contained in 02VRS:	«-»	«-»	«-»	
	Contained in 03VRS:	«-»	«-»	«-»	
	Contained in 04VRS:	«-»	«-»	«-»	
	Contained in 05VRS:	«-»	«-»	«-»	
	Contained in 06VRS:	«-»	«-»	«-»	«-»
	Contained in 07VRS:	«-»	«-»	«-»	«-»
	Contained in 08VRS:	«-»	«-»	«-»	«MPC»
	Supported by supply unit:	«-»			

The composition of a modular I/O has changed since the previous CCD phase progression. The content of parameter S-0-1500.0.3 (List of Module Type Codes) in a modular I/O is not identical with the content of parameter "P-0-1634.x.1, CCD: Module type codes of the modular I/Os".

As a result, there may be cases where the inputs or outputs are not operated correctly because modules of the modular I/O have been exchanged.

Warnings (Exxxx)

Cause	Remedy
New modular I/O was added to CCD group	Start command "P-0-1620.0.31, C7200 CCD: Command Apply I/O configuration" or write to parameter P-0-1634.x.1
Changes were made to known modular I/O in CCD group. Modules were exchanged or replaced by other modules or new modules were added	Undo changes to modular I/O - or - Inform CCD master about changes with command C7200 "CCD: Command Apply I/O configuration" - or - Write correct values to parameter P-0-1634.x.1

See also Functional Description of firmware "Cross Communication (CCD)"

E4017 - Attributes **Display:** E4017
 Ident N°: E4017

9.3 Possible Warnings When Operating Safety Technology (E3xxx)

9.3.1 Behavior in Case a Safety Technology Warning Occurs



With activated safety technology, warnings of category E31xx only occur in normal operation. When a safe operation is selected, the cause of the warning results in an error being triggered.

Via the setting in "P-0-0119, Best possible deceleration", the user can define the behavior of the drive taking place when non-fatal safety technology errors occur.

The drive automatically switches to safety related standstill or "Safe stop 1" (S2) and the output stage is switched off via two channels.

As soon as the axis has stopped, the axis signals safety; i.e., "safety technology status output controller" in "P-0-3214, Safety technology status word, channel 1" was set or the diagnosis input/output EA10n (channel 2) was set depending on the parameterization in "P-0-3210, Safety technology configuration".

9.3.2 E3100 Error when checking input signals

Allocation	Contained in 02VRS:	«MPB»	«MPH»	«MPD»	
	Contained in 03VRS:	«MPB»	«MPH»	«MPD»	
	Contained in 04VRS:	«MPB»	«MPH»	«MPD»	
	Contained in 05VRS:	«MPB»	«MPH»	«MPD»	
	Contained in 06VRS:	«MPB»	«MPH»	«MPD»	«MPC»
	Contained in 07VRS:	«MPB»	«MPH»	«MPD»	«MPC»
	Contained in 08VRS:	«MPB»	«MPH»	«MPD»	«MPC»
	Supported by supply unit:	«-»			

When the safety technology has been activated, the warning only occurs in normal operation. When a safety-related operation status is selected, the cause of the error causes the error "F3130 Error when checking input signals" or "F3141 Selection validation error" to be triggered.

Warnings (Exxxx)

9.3.4 E3102 Actual position values validation error

Allocation	Contained in 02VRS:	«MPB»	«MPH»	«MPD»	
	Contained in 03VRS:	«MPB»	«MPH»	«MPD»	
	Contained in 04VRS:	«MPB»	«MPH»	«MPD»	
	Contained in 05VRS:	«MPB»	«MPH»	«MPD»	
	Contained in 06VRS:	«MPB»	«MPH»	«MPD»	«MPC»
	Contained in 07VRS:	«-»	«-»	«-»	«-»
	Contained in 08VRS:	«-»	«-»	«-»	«-»
	Supported by supply unit:	«-»			

When both safety technology channels have been homed (confer "S-0-0403, Position feedback value status" for channel 1 and "P-0-3213, Safety technology operating status" for channel 2), a validation check is cyclically carried out for their actual position values. The difference of the actual position values mustn't exceed an internally defined threshold.

When the safety technology has been activated, this warning only occurs in normal operation. When a safety function is selected, the cause of the error causes the error "F3117 Actual position values validation error" to be triggered.

Cause	Remedy
Implausible values on channel 1 and 2 resulted from cyclic comparison of actual position values. An internally calculated tolerance threshold is used for this comparison	Reestablish safety related reference

E3102 - Attributes Display: E3102
 Ident N°: E3102

9.3.5 E3103 Dynamization failed

Allocation	Contained in 02VRS:	«MPB»	«MPH»	«MPD»	
	Contained in 03VRS:	«MPB»	«MPH»	«MPD»	
	Contained in 04VRS:	«MPB»	«MPH»	«MPD»	
	Contained in 05VRS:	«MPB»	«MPH»	«MPD»	
	Contained in 06VRS:	«MPB»	«MPH»	«MPD»	«MPC»
	Contained in 07VRS:	«MPB»	«MPH»	«MPD»	«MPC»
	Contained in 08VRS:	«MPB»	«MPH»	«MPD»	«MPC»
	Supported by supply unit:	«-»			

For dynamization of safety function selection a dynamic signal is applied to the selection elements, in order to detect errors in the wiring of the input signals. The signal shape of the dynamic signal is monitored, too.

The monitoring refers to the signal at the dynamization input EA30 and, in the case of separate dynamization (to be set via "P-0-3210, Safety technology configuration"), additionally to the dynamization input for channel 1 ("P-0-3212, Safety technology control word, channel 1").

When the safety technology has been activated, this warning only occurs in normal operation. When a safety function is selected, the cause of the error causes the error "F3134 Dynamization time interval incorrect" to be triggered.

Warnings (Exxxx)

Cause	Remedy
Within time "P-0-3223, Time interval for dynamization of safety function selection" there hasn't any dynamization pulse (low level) occurred at dynamization input EA30 or "dynamization input channel 1"	Remove cause of error in wiring of dynamization input - or - In the case of internal dynamization, make sure that only one of involved axes has been configured as master for dynamization of safety function selection ("P-0-3210, Safety technology configuration") - or - In the case of external dynamization, use appropriate signal source - or - Make sure that in involved slave axes values for "P-0-3223, Time interval for dynamization of safety function selection" and "P-0-3224, Duration of dynamization pulse of safety function selection" are greater than or equal to values in master axis

E3103 - Attributes Display: E3103
 Ident N°: E3103

9.3.6 E3104 Safety parameters validation error

Allocation	Contained in 02VRS:	«MPB»	«MPH»	«MPD»	
	Contained in 03VRS:	«MPB»	«MPH»	«MPD»	
	Contained in 04VRS:	«MPB»	«MPH»	«MPD»	
	Contained in 05VRS:	«MPB»	«MPH»	«MPD»	
	Contained in 06VRS:	«MPB»	«MPH»	«MPD»	«MPC»
	Contained in 07VRS:	«MPB»	«MPH»	«MPD»	«MPC»
	Contained in 08VRS:	«MPB»	«MPH»	«MPD»	«MPC»
	Supported by supply unit:	«-»			

In the operating mode, a validation check is cyclically carried out for the safety parameters of channel 1 and channel 2.

When the safety technology has been activated, this warning only occurs in normal operation. When a safety function is selected, the cause of the error causes the error "F3140 Safety parameters validation error" or "F7040 Validation error parameterized - effective threshold" to be triggered.

Cause	Remedy
A comparison has shown that channel 1 and channel 2 are not working with the same safety parameters	Execute command "P-0-3204, C3000 Synchronize and store safety technology IDN command"; channel 2 thereby accepts parameters of channel 1

E3104 - Attributes Display: E3104
 Ident N°: E3104

9.3.7 E3105 Validation error of safe operation mode

Allocation	Contained in 02VRS:	«MPB»	«MPH»	«MPD»	
	Contained in 03VRS:	«MPB»	«MPH»	«MPD»	
	Contained in 04VRS:	«MPB»	«MPH»	«MPD»	
	Contained in 05VRS:	«MPB»	«MPH»	«MPD»	
	Contained in 06VRS:	«MPB»	«MPH»	«MPD»	«MPC»
	Contained in 07VRS:	«MPB»	«MPH»	«MPD»	«MPC»
	Contained in 08VRS:	«MPB»	«MPH»	«MPD»	«MPC»
	Supported by supply unit:	«-»			

Warnings (Exxxx)

The active safety technology operating states ("safety related operating modes") of channel 1 and channel 2 are cyclically and via two channels checked for validity; they may differ for a maximum of 5 seconds.

The criteria for transition to a new safety technology operating status selected have not been fulfilled in one channel. This channel remains in old the status - the other channel already went to the new status.



When the safety technology has been activated, this warning only occurs in normal operation. When a safety function is selected, the cause of the error causes the error "F7042 Validation error safety related operating mode" to be triggered.

Cause	Remedy
Time, velocity or position thresholds were incorrectly parameterized	Check time, velocity or position thresholds relevant for respective transition and adjust them, if necessary

E3105 - Attributes Display: E3105
 Ident N°: E3105

9.3.8 E3106 System error safety technology

Allocation	Contained in 02VRS:	«MPB»	«MPH»	«MPD»	
	Contained in 03VRS:	«MPB»	«MPH»	«MPD»	
	Contained in 04VRS:	«MPB»	«MPH»	«MPD»	
	Contained in 05VRS:	«MPB»	«MPH»	«MPD»	
	Contained in 06VRS:	«MPB»	«MPH»	«MPD»	«MPC»
	Contained in 07VRS:	«MPB»	«MPH»	«MPD»	«MPC»
	Contained in 08VRS:	«MPB»	«MPH»	«MPD»	«MPC»
	Supported by supply unit:	«-»			



In the firmware versions 02VRS, 03VRS and 04VRS, the name of the warning is "E3106 System error channel 2".

When the safety technology has been activated, this warning only occurs in normal operation. When a safety function is selected, the cause of the error causes the error "F3146 System error channel 2" or "F3147 System error channel 1" to be triggered (as of firmware versions 05VRS).

Cause	Remedy
System error	Via parameter mode switch to operating mode - or - Reset optional safety technology module by switching control voltage off and on If error occurs repeatedly, replace control section or entire drive controller; use hardware configuration of same type



Only Rexroth service engineers or especially trained users are allowed to replace the control section. The replacement of the entire drive controller is described in the Project Planning Manual for the power section.

Only Rexroth service engineers are allowed to replace optional modules of the control section (e.g. optional encoder module).

E3106 - Attributes Display: E3106
 Ident N°: E3106

9.3.9 E3107 Safe reference missing

Allocation	Contained in 02VRS:	«MPB»	«MPH»	«MPD»	
	Contained in 03VRS:	«MPB»	«MPH»	«MPD»	
	Contained in 04VRS:	«MPB»	«MPH»	«MPD»	
	Contained in 05VRS:	«MPB»	«MPH»	«MPD»	
	Contained in 06VRS:	«MPB»	«MPH»	«MPD»	«MPC»
	Contained in 07VRS:	«MPB»	«MPH»	«MPD»	«MPC»
	Contained in 08VRS:	«MPB»	«MPH»	«MPD»	«MPC»
	Supported by supply unit:	«-»			

A check showed that, when the special mode "safe motion" with configured safety function "safety related limited absolute position" (up to MPx06) or "Safely-monitored position" (as of MPx07) was selected, there is no "safe reference" existing.

Cause	Remedy
Monitoring of safety related end positions has been configured; requirement that channel 2 has been homed is missing (can also be recognized in "P-0-3238, Extended safety technology status"). No safety function has been selected (i.e., drive is in normal operation)	<ol style="list-style-type: none"> 1. Set drive enable 2. For absolute measuring systems: Execute "P-0-3228, C4000 Homing procedure command channel 2" in order to establish "safe reference" on channel 2 <p>- or -</p> <p>For all other measuring systems: Execute "S-0-0148, C0600 Drive-controlled homing procedure command" (C4000 for establishing safe reference of channel 2 is integrated)</p>

Description of error reaction: "Behavior in Case a Safety Technology Warning Occurs"

See also documentation

- **Up to MPx06:** "Integrated Safety Technology, index entry "Safety related homing procedure""
- **As of MPx07:** "Integrated Safety Technology According to IEC 61508, index entry "Safe homing procedure""

E3107 - Attributes	Display:	E3107
	Ident N°:	E3107

9.3.10 E3108 Safely-monitored deceleration exceeded

Allocation	Contained in 02VRS:	«-»	«-»	«-»	
	Contained in 03VRS:	«-»	«-»	«-»	
	Contained in 04VRS:	«-»	«-»	«-»	
	Contained in 05VRS:	«MPB»	«MPH»	«MPD»	
	Contained in 06VRS:	«MPB»	«MPH»	«MPD»	«MPC»
	Contained in 07VRS:	«MPB»	«MPH»	«MPD»	«MPC»
	Contained in 08VRS:	«MPB»	«MPH»	«MPD»	«MPC»
	Supported by supply unit:	«-»			



Up to MPx06, the name of this diagnostic message was "E3108 Safety related deceleration exceeded".

During the monitoring function "Safely-monitored stopping process on basis of actual velocity" - which is carried out in consequence of a change in selection or a safety technology error - the actual velocity exceeds the threshold "P-0-3283, Safely-monitored deceleration, veloc. envelope curve".

For the time during which the threshold is exceeded, the incorrect distance is determined (by integration of the velocity differences).

Warnings (Exxxx)

The warning E3108 is generated as long as an incorrect distance is detected which is smaller than the value in the position standstill window "P-0-3230, Monitoring window for safe stop 2".

When the incorrect distance exceeds the position standstill window (P-0-3230), the error F7051 or F8135 is generated.

Cause	Remedy
During transition to special mode, drive is not able to reach standstill, within corresponding transition time ("P-0-3220, Tolerance time transition from normal operation"/"P-0-3225, Tolerance time transition from safe operation"), with deceleration parameterized in "P-0-3282, Safely-monitored deceleration"	Adjust command value input to parameterized values
One or several of values selected for the following parameters are not useful: <ul style="list-style-type: none"> • P-0-3282, Safely-monitored deceleration, • P-0-3226, Delay Safely-monitored deceleration, • P-0-3233, Velocity threshold for safe standstill, • "P-0-3220, Tolerance time transition from normal operation" or • P-0-3225, Tolerance time transition from safe operation 	Check parameter settings and change them, if necessary

See also documentation

- **Up to MPx06:** "Integrated Safety Technology", index entry "Safety related monitored stopping process"
- **As of MPx07:** "Integrated Safety Technology According to IEC61508", index entry "Safely-monitored stopping process"

E3108 - Attributes Display: E3108
 Ident N°: E3108

9.3.11 E3110 Time interval of forced dynamization exceeded

Allocation	Contained in 02VRS:	«MPB»	«MPH»	«MPD»	
	Contained in 03VRS:	«MPB»	«MPH»	«MPD»	
	Contained in 04VRS:	«MPB»	«MPH»	«MPD»	
	Contained in 05VRS:	«MPB»	«MPH»	«MPD»	
	Contained in 06VRS:	«MPB»	«MPH»	«MPD»	«MPC»
	Contained in 07VRS:	«MPB»	«MPH»	«MPD»	«MPC»
	Contained in 08VRS:	«MPB»	«MPH»	«MPD»	«MPC»
	Supported by supply unit:	«-»			

In parameter "P-0-0103, Time interval of forced dynamization" it is possible to set a time interval within which the starting lockout has to be activated. This time interval has been exceeded.

Cause	Remedy
Setting of time interval in parameter "P-0-0103, Time interval of forced dynamization" does not comply with requirements	Set time interval in parameter "P-0-0103, Time interval of forced dynamization" according to requirements
Starting lockout has not been activated within time interval that was set	Activate starting lockout with drive controller being active

E3110 - Attributes Display: E3110
 Ident N°: E3110

9.3.12 E3115 Prewarning, end of brake check time interval

Allocation	Contained in 02VRS:	«-»	«-»	«-»	
	Contained in 03VRS:	«MPB»	«MPH»	«MPD»	
	Contained in 04VRS:	«MPB»	«MPH»	«MPD»	
	Contained in 05VRS:	«MPB»	«MPH»	«MPD»	
	Contained in 06VRS:	«MPB»	«MPH»	«MPD»	«MPC»
	Contained in 07VRS:	«MPB»	«MPH»	«MPD»	«MPC»
	Contained in 08VRS:	«MPB»	«MPH»	«MPD»	«MPC»
	Supported by supply unit:	«-»			

When "time interval of holding brake check" was activated in "P-0-0525, Holding brake control word" or the function "safe braking and holding system" is used, the drive monitors the time which has passed since the last holding brake check.

Cause	Remedy
Drive had been put into operation and drive enable was set; after 5 minutes, drive generates warning E3115	Brake check ("P-0-0541, C2100 Holding system check command") must be carried out within 15 minutes after drive was put into operation and drive enable was set
Space of time since last holding brake check has approached time interval parameterized in "P-0-0550, Time interval holding system check" or "P-0-3302, SBS: Time interval brake check" by 15 minutes or less	Start brake check within 15 minutes after occurrence of E3115 ("P-0-0541, C2100 Holding system check command")

See also Functional Description of firmware "Motor Holding Brake"

See also documentation

- **Up to MPx06:** "Integrated Safety Technology"
- **As of MPx07:** "Integrated Safety Technology According to IEC61508"

E3115 - Attributes	Display:	E3115
	Ident N°:	E3115

9.3.13 E3116 Nominal load torque of holding system reached

Allocation	Contained in 02VRS:	«-»	«-»	«-»	
	Contained in 03VRS:	«-»	«-»	«-»	
	Contained in 04VRS:	«MPB»	«MPH»	«MPD»	
	Contained in 05VRS:	«MPB»	«MPH»	«MPD»	
	Contained in 06VRS:	«MPB»	«MPH»	«MPD»	«MPC»
	Contained in 07VRS:	«MPB»	«MPH»	«MPD»	«MPC»
	Contained in 08VRS:	«MPB»	«MPH»	«MPD»	«MPC»
	Supported by supply unit:	«-»			

The current nominal load torque ("P-0-0551, Current load torque") has temporarily exceeded the nominal load torque of the holding system ("P-0-0547, Nominal load of holding system") or of the safe braking and holding system ("P-0-3303, SBS: Nominal load").

Cause	Remedy
"P-0-0551, Current load torque" is greater than nominal load torque of holding system ("P-0-0547, Nominal load of holding system") or nominal load torque of safe braking and holding system ("P-0-3303, SBS: Nominal load")	Avoid overload
Incorrect parameterization of "P-0-0547, Nominal load of holding system" or "P-0-3303, SBS: Nominal load"	Correct parameter setting

See also documentation

- **Up to MPx06:** "Integrated Safety Technology"

Warnings (Exxxx)

- **As of MPx07:** "Integrated Safety Technology According to IEC61508"

E3116 - Attributes
Display: E3116
Ident N°: E3116

9.4 Non-Fatal Warnings (E2xxx)

9.4.1 Behavior in Case a Non-Fatal Warning Occurs

In the case of warnings of **category E2xxx**, the drive normally does not carry out any drive reaction, unless the warning was generated due to a mains or undervoltage error. In this case, the behavior of the drive can be determined via the parameter "P-0-0118, Power supply, configuration".

A second group of warnings within this category signals that a limit value determined (parameterized) by the user has been exceeded.

A warning cannot be cleared; it disappears automatically after its cause was removed.

9.4.2 E2010 Position control with encoder 2 not possible

Allocation	Contained in 02VRS:	«-»	«-»	«-»	
	Contained in 03VRS:	«-»	«-»	«-»	
	Contained in 04VRS:	«MPB»	«MPH»	«MPD»	
	Contained in 05VRS:	«MPB»	«MPH»	«MPD»	
	Contained in 06VRS:	«MPB»	«MPH»	«MPD»	«MPC»
	Contained in 07VRS:	«MPB»	«MPH»	«MPD»	«MPC»
	Contained in 08VRS:	«MPB»	«MPH»	«MPD»	«MPC»
	Supported by supply unit:	«-»			

For operating modes using parameter "S-0-0520, Control word of axis controller" it is possible to switch the control encoder during operation.

If no second encoder has been defined as control encoder, this warning is generated when you try to switch to encoder 2.

E2010 - Attributes
Display: E2010
Ident N°: E2010

9.4.3 E2011 PLC - Warning no. 1

Allocation	Contained in 02VRS:	«-»	«MPH»	«-»	
	Contained in 03VRS:	«MPB»	«MPH»	«-»	
	Contained in 04VRS:	«MPB»	«MPH»	«-»	
	Contained in 05VRS:	«MPB»	«MPH»	«-»	
	Contained in 06VRS:	«MPB»	«MPH»	«-»	«MPC»
	Contained in 07VRS:	«MPB»	«MPH»	«-»	«MPC»
	Contained in 08VRS:	«MPB»	«MPH»	«-»	«MPC»
	Supported by supply unit:	«-»			

In conjunction with technology functions, the PLC integrated in the drive allows the user to generate warnings from within the PLC program.

Causes of and remedies for a PLC warning depend on the particular PLC project (or the active Rexroth technology function) and can be found in the description of the particular technology function.

Tip: As of firmware versions MPx08/MPx17, the diagnostic message text can be edited via the integrated PLC. This allows the user to assign meaningful diagnostic messages.

E2011 - Attributes
Display: E2011
Ident N°: E2011

9.4.4 E2012 PLC - Warning no. 2

Allocation	Contained in 02VRS:	«-»	«MPH»	«-»	
	Contained in 03VRS:	«MPB»	«MPH»	«-»	
	Contained in 04VRS:	«MPB»	«MPH»	«-»	
	Contained in 05VRS:	«MPB»	«MPH»	«-»	
	Contained in 06VRS:	«MPB»	«MPH»	«-»	«MPC»
	Contained in 07VRS:	«MPB»	«MPH»	«-»	«MPC»
	Contained in 08VRS:	«MPB»	«MPH»	«-»	«MPC»
	Supported by supply unit:	«-»			

In conjunction with technology functions, the PLC integrated in the drive allows the user to generate warnings from within the PLC program.

Causes of and remedies for a PLC warning depend on the particular PLC project (or the active Rexroth technology function) and can be found in the description of the particular technology function.

Tip: As of firmware versions MPx08/MPx17, the diagnostic message text can be edited via the integrated PLC. This allows the user to assign meaningful diagnostic messages.

E2012 - Attributes	Display:	E2012
	Ident N°:	E2012

9.4.5 E2013 PLC - Warning no. 3

Allocation	Contained in 02VRS:	«-»	«MPH»	«-»	
	Contained in 03VRS:	«MPB»	«MPH»	«-»	
	Contained in 04VRS:	«MPB»	«MPH»	«-»	
	Contained in 05VRS:	«MPB»	«MPH»	«-»	
	Contained in 06VRS:	«MPB»	«MPH»	«-»	«MPC»
	Contained in 07VRS:	«MPB»	«MPH»	«-»	«MPC»
	Contained in 08VRS:	«MPB»	«MPH»	«-»	«MPC»
	Supported by supply unit:	«-»			

In conjunction with technology functions, the PLC integrated in the drive allows the user to generate warnings from within the PLC program.

Causes of and remedies for a PLC warning depend on the particular PLC project (or the active Rexroth technology function) and can be found in the description of the particular technology function.

Tip: As of firmware versions MPx08/MPx17, the diagnostic message text can be edited via the integrated PLC. This allows the user to assign meaningful diagnostic messages.

E2013 - Attributes	Display:	E2013
	Ident N°:	E2013

9.4.6 E2014 PLC - Warning no. 4

Allocation	Contained in 02VRS:	«-»	«MPH»	«-»	
	Contained in 03VRS:	«MPB»	«MPH»	«-»	
	Contained in 04VRS:	«MPB»	«MPH»	«-»	
	Contained in 05VRS:	«MPB»	«MPH»	«-»	
	Contained in 06VRS:	«MPB»	«MPH»	«-»	«MPC»
	Contained in 07VRS:	«MPB»	«MPH»	«-»	«MPC»
	Contained in 08VRS:	«MPB»	«MPH»	«-»	«MPC»
	Supported by supply unit:	«-»			

In conjunction with technology functions, the PLC integrated in the drive allows the user to generate warnings from within the PLC program.

Causes of and remedies for a PLC warning depend on the particular PLC project (or the active Rexroth technology function) and can be found in the description of the particular technology function.

Warnings (Exxxx)

Tip: As of firmware versions MPx08/MPx17, the diagnostic message text can be edited via the integrated PLC. This allows the user to assign meaningful diagnostic messages.

E2014 - Attributes Display: E2014
 Ident N°: E2014

9.4.7 E2015 PLC - Warning no. 5

Allocation	Contained in 02VRS:	«-»	«-»	«-»	
	Contained in 03VRS:	«-»	«-»	«-»	
	Contained in 04VRS:	«-»	«-»	«-»	
	Contained in 05VRS:	«-»	«-»	«-»	
	Contained in 06VRS:	«-»	«-»	«-»	«-»
	Contained in 07VRS:	«-»	«-»	«-»	«-»
	Contained in 08VRS:	«MPB»	«MPH»	«-»	«MPC»
	Supported by supply unit:	«-»			

In conjunction with technology functions, the PLC integrated in the drive allows the user to generate warnings from within the PLC program.

Causes of and remedies for a PLC warning depend on the particular PLC project (or the active Rexroth technology function) and can be found in the description of the particular technology function.

Tip: As of firmware versions MPx08/MPx17, the diagnostic message text can be edited via the integrated PLC. This allows the user to assign meaningful diagnostic messages.

E2015 - Attributes Display: E2015
 Ident N°: E2015

9.4.8 E2016 PLC - Warning no. 6

Allocation	Contained in 02VRS:	«-»	«-»	«-»	
	Contained in 03VRS:	«-»	«-»	«-»	
	Contained in 04VRS:	«-»	«-»	«-»	
	Contained in 05VRS:	«-»	«-»	«-»	
	Contained in 06VRS:	«-»	«-»	«-»	«-»
	Contained in 07VRS:	«-»	«-»	«-»	«-»
	Contained in 08VRS:	«MPB»	«MPH»	«-»	«MPC»
	Supported by supply unit:	«-»			

In conjunction with technology functions, the PLC integrated in the drive allows the user to generate warnings from within the PLC program.

Causes of and remedies for a PLC warning depend on the particular PLC project (or the active Rexroth technology function) and can be found in the description of the particular technology function.

Tip: As of firmware versions MPx08/MPx17, the diagnostic message text can be edited via the integrated PLC. This allows the user to assign meaningful diagnostic messages.

E2016 - Attributes Display: E2016
 Ident N°: E2016

9.4.9 E2017 PLC - Warning no. 7

Allocation	Contained in 02VRS:	«-»	«-»	«-»	
	Contained in 03VRS:	«-»	«-»	«-»	
	Contained in 04VRS:	«-»	«-»	«-»	
	Contained in 05VRS:	«-»	«-»	«-»	
	Contained in 06VRS:	«-»	«-»	«-»	«-»
	Contained in 07VRS:	«-»	«-»	«-»	«-»
	Contained in 08VRS:	«MPB»	«MPH»	«-»	«MPC»
	Supported by supply unit:	«-»			

Warnings (Exxxx)

9.4.11 E2026 Undervoltage in power section

Allocation	Contained in 02VRS:	«MPB»	«MPH»	«MPD»	
	Contained in 03VRS:	«MPB»	«MPH»	«MPD»	
	Contained in 04VRS:	«MPB»	«MPH»	«MPD»	
	Contained in 05VRS:	«MPB»	«MPH»	«MPD»	
	Contained in 06VRS:	«MPB»	«MPH»	«MPD»	«MPC»
	Contained in 07VRS:	«MPB»	«MPH»	«MPD»	«MPC»
	Contained in 08VRS:	«MPB»	«MPH»	«MPD»	«MPC»
	Supported by supply unit:	«HMV»			

The DC bus voltage value is monitored by the drive controller and the supply unit.

Drive Controllers HMS, HMD, HCS

If the DC bus voltage falls below the minimum value determined for the drive (see value of "P-0-0114, Undervoltage threshold") or it reacts to "DC bus not ok" of the module bus, the device generates the warning E2026 if "non-fatal warning" has been set with regard to the reaction to undervoltage in "P-0-0118, Power supply, configuration".



When drive enable is set without DC bus voltage (drive signals "bb"), the error message F2026 is generated in spite of warning having been parameterized.

Supply Unit HMV01.1R / HMV02.1R

If the DC bus voltage falls below the threshold value determined for the respective supply unit (see table below), the warning E2026 is displayed at the device and "DC bus not ok" is signaled via the module bus. The circuit is not interrupted yet!

Supply unit	Hardware index (see type plate)	Threshold value
HMV01.1R-W0018	Up to A38	DC 670 V
	From A39 upwards	DC 600 V
HMV01.1R-W0045	Up to A39	DC 670 V
	From A40 upwards	DC 600 V
HMV01.1R-W0060	Up to A39	DC 670 V
	From A40 upwards	DC 600 V
HMV01.1R-W0120	From A00 upwards	DC 600 V

Fig. 9-3: Threshold Values for Undervoltage in DC Bus

Cause	Remedy
Power is switched off without previous drive deactivation by means of drive enable ("AF")	Check logic for activating drive in connected control unit
Malfunction or overload of power supply	Check power supply
Mains failure	Check cause of mains failure, switch mains voltage on again

See also Functional Description of firmware "Power Supply"

E2026 - Attributes	Display:	E2026
	Ident N°:	E2026

9.4.12 E2040 Device overtemperature 2 prewarning

Allocation	Contained in 02VRS:	«MPB»	«MPH»	«MPD»	
	Contained in 03VRS:	«MPB»	«MPH»	«MPD»	
	Contained in 04VRS:	«MPB»	«MPH»	«MPD»	
	Contained in 05VRS:	«MPB»	«MPH»	«MPD»	
	Contained in 06VRS:	«MPB»	«MPH»	«MPD»	«MPC»
	Contained in 07VRS:	«MPB»	«MPH»	«MPD»	«MPC»
	Contained in 08VRS:	«MPB»	«MPH»	«MPD»	«MPC»
	Supported by supply unit:	«-»			

A switch-off value for the second temperature sensor is stored in element 3 of parameter "P-0-4059, Electric type data of power section".

If the parameter "P-0-0816, Amplifier temperature 2" exceeds the switch-off threshold, the warning E2040 is output for 30 seconds. Afterwards, the controller is switched off with the non-fatal error F2040.

Before the controller is switched off, it is possible to stop the axis via the control unit in accordance with the process (e.g. terminate processing, leave collision area etc.) or to reduce the load of the drive controller.

Cause	Remedy
Ambient temperature too high. Specified performance data are valid up to an ambient temperature of 40 C.	Reduce ambient temperature, e.g. by cooling the control cabinet
Heat sink of device is dirty	Clean heat sink
Convection is prevented by other components or mounting position in control cabinet	Mount device vertically and provide sufficient space for ventilating heat sink
Blower of device is defective	Replace device

E2040 - Attributes Display: E2040
 Ident N°: E2040

9.4.13 E2047 Interpolation velocity = 0

Allocation	Contained in 02VRS:	«MPB»	«MPH»	«MPD»	
	Contained in 03VRS:	«MPB»	«MPH»	«MPD»	
	Contained in 04VRS:	«MPB»	«MPH»	«MPD»	
	Contained in 05VRS:	«-»	«-»	«-»	
	Contained in 06VRS:	«-»	«-»	«-»	«-»
	Contained in 07VRS:	«-»	«-»	«-»	«-»
	Contained in 08VRS:	«-»	«-»	«-»	«-»
	Supported by supply unit:	«-»			

In operating states/ operating modes in which the drive-internal position command value interpolator is active, the preset velocity effective in the drive is monitored with regard to the value "0"; i.e. the monitor is active in the following operating modes or operating states:

- | | |
|------------------------|--|
| Operating Modes | <ul style="list-style-type: none"> • drive-internal interpolation • drive-controlled positioning • positioning block mode • Drive Halt |
| Commands | <ul style="list-style-type: none"> • position spindle • drive-controlled homing • automatic control loop setting • ... |

Warnings (Exxxx)

Cause	Remedy
Incorrect velocity is preset (value = "0") (cf. "S-0-0259, Positioning velocity", "S-0-0041, Homing velocity", "P-0-4007, Positioning block velocity"[i], "S-0-0222, Spindle positioning speed", "S-0-0091, Bipolar velocity limit value", "P-0-0143, Synchronization velocity", "P-0-0686, Additive position command value, positioning velocity")	Check parameterization or cyclic command value of control unit and set value for preset velocity unequal zero
Analog input to which preset velocity was assigned is defective or not connected	Check wiring and function of analog input and, if necessary, replace cable or control section, or the entire drive controller



Only Rexroth service engineers or especially trained users are allowed to replace the control section. The replacement of the entire drive controller is described in the Project Planning Manual for the power section.

E2047 - Attributes Display: E2047
 Ident N°: E2047

9.4.14 E2048 Interpolation acceleration = 0

Allocation	Contained in 02VRS:	«MPB»	«MPH»	«MPD»	
	Contained in 03VRS:	«MPB»	«MPH»	«MPD»	
	Contained in 04VRS:	«MPB»	«MPH»	«MPD»	
	Contained in 05VRS:	«-»	«-»	«-»	
	Contained in 06VRS:	«-»	«-»	«-»	«-»
	Contained in 07VRS:	«-»	«-»	«-»	«-»
	Contained in 08VRS:	«-»	«-»	«-»	«-»
	Supported by supply unit:	«-»			

In operating states/ operating modes in which the drive-internal position command value interpolator is active, the preset acceleration effective in the drive is monitored with regard to the value "0" [without acceleration (deceleration) a preset velocity can never be reached; slowing down with a deceleration "0" isn't possible either].



The input values of the parameters are converted to a drive-internal format. This is why input values > "0" can, internally, also cause an acceleration = "0". The parameter values which drive-internally still cause an acceleration > "0" can be calculated.

Operating Modes	The monitor is active in the following operating modes or operating states:
	<ul style="list-style-type: none"> • drive-internal interpolation • drive-controlled positioning • positioning block mode • Drive Halt
Commands	<ul style="list-style-type: none"> • position spindle • drive-controlled homing • automatic control loop setting • ...

Warnings (Exxxx)

Cause	Remedy
Incorrect acceleration is preset (value = "0") (vgl. "S-0-0260, Positioning acceleration", "S-0-0042, Homing acceleration", "S-0-0138, Bipolar acceleration limit value", "S-0-0359, Positioning deceleration", "P-0-0142, Synchronization acceleration", "P-0-0687, Additive position command value, positioning acceleration")	Check parameterization or cyclic command value of control unit and set value for preset acceleration > "0"

E2048 - Attributes **Display:** E2048
 Ident N°: E2048

9.4.15 E2049 Positioning velocity >= limit value

Allocation	Contained in 02VRS:	«MPB»	«MPH»	«MPD»	
	Contained in 03VRS:	«MPB»	«MPH»	«MPD»	
	Contained in 04VRS:	«MPB»	«MPH»	«MPD»	
	Contained in 05VRS:	«MPB»	«MPH»	«MPD»	
	Contained in 06VRS:	«MPB»	«MPH»	«MPD»	«MPC»
	Contained in 07VRS:	«MPB»	«MPH»	«MPD»	«MPC»
	Contained in 08VRS:	«MPB»	«MPH»	«MPD»	«MPC»
	Supported by supply unit:	«-»			

In the operation modes in which the drive-internal position command value interpolator is active, the velocity command value (positioning velocity) effective in the drive is limited to the smallest parameterized velocity limit value.

This means that the monitor is active in the following operation modes or operating states:

- | | |
|------------------------|--|
| Operation Modes | <ul style="list-style-type: none"> • Drive-internal interpolation • Drive-controlled positioning • Positioning block mode |
| Commands | <ul style="list-style-type: none"> • Position spindle • Drive-controlled homing procedure • Automatic control loop setting • ... |

Cause	Remedy
Incorrect velocity has been preset (parameterized or cyclically preset value is too high) (cf. "S-0-0259, Positioning velocity", "S-0-0041, Homing velocity", "P-0-4007, Positioning block velocity" [i], "S-0-0222, Spindle positioning speed", "S-0-0091, Bipolar velocity limit value", "S-0-0038, Positive velocity limit value", "S-0-0039, Negative velocity limit value")	Check parameterization or cyclic command value of control unit and set value for used preset velocity smaller than value from "S-0-0091, Bipolar velocity limit value", "S-0-0038, Positive velocity limit value" or "S-0-0039, Negative velocity limit value" Note: Specified velocity is also affected by S-0-0108; check S-0-0108.
"S-0-0091, Bipolar velocity limit value", "S-0-0038, Positive velocity limit value" or "S-0-0039, Negative velocity limit value" incorrectly parameterized	Check parameter contents of "S-0-0091, Bipolar velocity limit value", "S-0-0038, Positive velocity limit value" and "S-0-0039, Negative velocity limit value". Check whether parameter possibly has been assigned to an analog input or is contained in cyclic data
Analog input to which "S-0-0091, Bipolar velocity limit value", "S-0-0038, Positive velocity limit value" or "S-0-0039, Negative velocity limit value" was assigned is defective or not connected	Check wiring and function of analog input and, if necessary, replace cable or control section, or the entire drive controller

9.4.17 E2051 Motor overtemp. prewarning

Allocation	Contained in 02VRS:	«MPB»	«MPH»	«MPD»	
	Contained in 03VRS:	«MPB»	«MPH»	«MPD»	
	Contained in 04VRS:	«MPB»	«MPH»	«MPD»	
	Contained in 05VRS:	«MPB»	«MPH»	«MPD»	
	Contained in 06VRS:	«MPB»	«MPH»	«MPD»	«MPC»
	Contained in 07VRS:	«MPB»	«MPH»	«MPD»	«MPC»
	Contained in 08VRS:	«MPB»	«MPH»	«MPD»	«MPC»
	Supported by supply unit:	«-»			

The motor temperature measured by the temperature sensor approaches the limit value and has reached "S-0-0201, Motor warning temperature". The controller outputs warning E2051.

As of MPx07V14: This warning is also generated if the motor load calculated in the temperature model of the motor has exceeded the prewarning threshold.

The drive is not switched off (F2019) until the motor temperature has reached the limit value in "S-0-0204, Motor shutdown temperature".

Cause	Remedy
Incorrect parameterization of "S-0-0201, Motor warning temperature"	Check and correct parameterization of "S-0-0201, Motor warning temperature" by means of motor or temperature sensor data sheet Check temperature display (S-0-0383) of motor
As of MPx07V14: Incorrect parameterization of "P-0-0468, Prewarning threshold of therm. motor load"	Check parameterization of temperature model (P-0-4034, P-0-4035, P-0-4037). Check motor load and prewarning threshold (P-0-0446, P-0-0468)
Motor is overloaded. Effective torque demanded from motor has been above allowed continuous torque too long	Check dimensioning of motor and reduce motor load, e.g., by reducing feedrate in cutting operations. Or, in case of installations that have been operated for a long time, check whether drive conditions have changed (with regard to dirt accumulation, friction, moved masses, etc.)
Line interruption, ground fault or short circuit in line for motor temperature monitoring	Check line for motor temperature monitoring for line interruption, ground fault or short circuit
Instability in speed control loop	Check parameterization of speed control loop
Fan / cooler defective	Check fan / cooler

See also Functional Description of firmware "Motor Temperature Monitoring".

E2051 - Attributes	Display:	E2051
	Ident N°:	E2051

9.4.18 E2053 Target position out of travel range

Allocation	Contained in 02VRS:	«MPB»	«MPH»	«MPD»	
	Contained in 03VRS:	«MPB»	«MPH»	«MPD»	
	Contained in 04VRS:	«MPB»	«MPH»	«MPD»	
	Contained in 05VRS:	«MPB»	«MPH»	«MPD»	
	Contained in 06VRS:	«MPB»	«MPH»	«MPD»	«MPC»
	Contained in 07VRS:	«MPB»	«MPH»	«MPD»	«MPC»
	Contained in 08VRS:	«MPB»	«MPH»	«MPD»	«MPC»
	Supported by supply unit:	«-»			

In operation modes with internal position command value generation a check is run, before a movement is carried out, in order to find out whether the pre-set target position ("S-0-0258, Target position", "S-0-0282, Positioning

Warnings (Exxxx)

command value" or "P-0-4006, Positioning block target position" [i]) is within the allowed travel range of the drive.

The allowed travel range of the drive is defined by

- S-0-0049, Positive position limit value
- S-0-0050, Negative position limit value

The position limit value monitor and thus the monitoring of the allowed travel range is activated in "S-0-0055, Position polarities". The position limit value monitor is only active, when the selected encoder is in reference.

The reaction to a travel range error can be set in "P-0-0090, Travel range limit parameter".



When the position limit value monitor has been activated and the target position is outside of the allowed travel range, a warning bit is set in "S-0-0012, Class 2 diagnostics". In addition, the message "S-0-0323, Target position outside of travel range" is set.

Up to MPx04: The positioning procedure is started.

As of MPx05: The positioning procedure is **not** started.

Cause	Remedy
Position limit values ("S-0-0049, Positive position limit value", "S-0-0050, Negative position limit value") incorrectly parameterized	Check parameterization of position limit values and adjust it according to desired travel range ("S-0-0049, Positive position limit value" has to be greater than "S-0-0050, Negative position limit value")
Position limit value monitor has been activated although it is not needed	Deactivate position limit value monitor if it is not needed (e.g., in modulo operation)
In the case of relative interpolation, value for travel range was set too high or several travel ranges that are added cause effective target position (cf. "P-0-0050, Effective target position") to be outside of position limits	Check preset travel range (cf. "S-0-0258, Target position") and, if necessary, adjust it in control unit program
In the case of absolute interpolation, preset target position is incorrect	Check preset target position (cf. "S-0-0258, Target position" or "S-0-0282, Positioning command value") and, if necessary, adjust it in control unit program (only enter "S-0-0258, Target position" within position limit values)
In "positioning block mode" one or more target positions have been incorrectly parameterized or incorrect positioning block is selected	Check parameterized target positions in "P-0-4006, Positioning block target position" and block selection ("P-0-4026, Positioning block selection"). In addition, check block selection via respective master communication (e.g., field bus or digital I/Os).

See also Functional Description of firmware "Position Limitation/Travel Range Limit Switch"

For "relative interpolation", see Functional Description of firmware "Drive-Controlled Positioning"

For "absolute interpolation", see Functional Description of firmware "Drive-Internal Interpolation"

E2053 - Attributes

Display: E2053
Ident N°: E2053

9.4.19 E2054 Not homed

Allocation	Contained in 02VRS:	«MPB»	«MPH»	«MPD»	
	Contained in 03VRS:	«MPB»	«MPH»	«MPD»	
	Contained in 04VRS:	«MPB»	«MPH»	«MPD»	
	Contained in 05VRS:	«MPB»	«MPH»	«MPD»	
	Contained in 06VRS:	«MPB»	«MPH»	«MPD»	«MPC»
	Contained in 07VRS:	«MPB»	«MPH»	«MPD»	«MPC»
	Contained in 08VRS:	«MPB»	«MPH»	«MPD»	«MPC»
	Supported by supply unit:	«-»			

Before a motion is carried out a check is run in the case of operating modes with drive-internal position command value generation (drive-internal interpolation, drive-controlled positioning and positioning block mode) to find out whether, with absolute target position preset ("S-0-0258, Target position" or "S-0-0282, Positioning command value", or "P-0-4006, Positioning block target position"), the measuring system used for positioning (cf. operating mode selection) has been homed.



When the warning E2054 appears, the drive stops or does not accept the target position or the positioning block. In parameter "S-0-0012, Class 2 diagnostics" a warning bit is set.

Cause	Remedy
Absolute positioning was started although position data reference of drive had not yet been established [drive has not been homed (cf. "S-0-0403, Position feedback value status")]	Establish absolute position data reference by starting command "S-0-0148, C0600 Drive-controlled homing procedure command" or "P-0-0012, C0300 Command Set absolute measuring"

See also Functional Description of firmware "Establishing the Position Data Reference"

E2054 - Attributes	Display:	E2054
	Ident N°:	E2054

9.4.20 E2055 Feedrate override S-0-0108 = 0

Allocation	Contained in 02VRS:	«MPB»	«MPH»	«MPD»	
	Contained in 03VRS:	«MPB»	«MPH»	«MPD»	
	Contained in 04VRS:	«MPB»	«MPH»	«MPD»	
	Contained in 05VRS:	«MPB»	«MPH»	«MPD»	
	Contained in 06VRS:	«MPB»	«MPH»	«MPD»	«MPC»
	Contained in 07VRS:	«MPB»	«MPH»	«MPD»	«MPC»
	Contained in 08VRS:	«MPB»	«MPH»	«MPD»	«MPC»
	Supported by supply unit:	«-»			

By means of the "S-0-0108, Feedrate override" it is possible to make a proportional scaling for the travel velocity of drive-controlled travel commands (0..100 %).

A feedrate override of 0 % causes the effective travel velocity to become "0". In spite of velocity command value being present (e. g. "S-0-0259, Positioning velocity"), the drive remains stopped at the current position or brakes down until reaching standstill.



The function of the feedrate override can be switched off by setting S-0-0108 = 100 %.

If S-0-0108 has been cyclically configured or assigned to an analog input, this configuration has to be changed.

Warnings (Exxxx)

Cause	Remedy
Parameter "S-0-0108, Feedrate override" was set to "0"	Set feedrate override > "0" so that drive moves. Full velocity is reached with 100%.
For devices with analog inputs: feedrate override via analog input has been activated and voltage at analog input is "0"	Apply voltage > "0" proportionally to desired velocity (+10 V corresponds to 100% of velocity) alternative: deactivate feedrate override
Infeed potentiometer of connected control unit was set to "0" or is incorrectly evaluated	Carefully actuate infeed potentiometer, check analog signal and evaluation
Analog input used for feedrate override or connecting cable is defective	Check and if necessary replace cable and control section



Only Rexroth service engineers or especially trained users are allowed to replace the control section. The replacement of the entire drive controller is described in the Project Planning Manual for the power section.

E2055 - Attributes Display: E2055
Ident N°: E2055

9.4.21 E2056 Torque limit = 0

Allocation	Contained in 02VRS:	«MPB»	«MPH»	«MPD»	
	Contained in 03VRS:	«MPB»	«MPH»	«MPD»	
	Contained in 04VRS:	«MPB»	«MPH»	«MPD»	
	Contained in 05VRS:	«MPB»	«MPH»	«MPD»	
	Contained in 06VRS:	«MPB»	«MPH»	«MPD»	«MPC»
	Contained in 07VRS:	«MPB»	«MPH»	«MPD»	«MPC»
	Contained in 08VRS:	«MPB»	«MPH»	«MPD»	«MPC»
	Supported by supply unit:	«-»			

To protect the drive or the connected mechanical system against mechanical overload the maximum torque or the maximum force can be limited to allowed values.

Cause	Remedy
One of the torque-/force-limiting parameters has the value "0"	Check parameters "S-0-0082, Torque/force limit value positive"; "S-0-0083, Torque/force limit value negative"; "S-0-0092, Bipolar torque/force limit value" and "P-0-0109, Torque/force peak limit" and enter "correct" limit value (unequal "0")
One of the torque-/force-limiting parameters has been assigned to analog input and voltage at analog input is "0"	Apply voltage > 0 proportionally to desired torque/force limit value Note: Scaling of analog input defines scaling of analog input voltage (see also Functional Description of firmware "Analog Inputs")
Potentiometer of connected control unit was set to "0" or is incorrectly evaluated	Carefully actuate potentiometer, check analog signal and evaluation
Cable connected at analog input for torque/force limitation is defective	Check and, if necessary, replace cable

Warnings (Exxxx)

9.4.23 E2059 Velocity command value limit active

Allocation	Contained in 02VRS:	«MPB»	«MPH»	«MPD»	
	Contained in 03VRS:	«MPB»	«MPH»	«MPD»	
	Contained in 04VRS:	«MPB»	«MPH»	«MPD»	
	Contained in 05VRS:	«MPB»	«MPH»	«MPD»	
	Contained in 06VRS:	«MPB»	«MPH»	«MPD»	«MPC»
	Contained in 07VRS:	«MPB»	«MPH»	«MPD»	«MPC»
	Contained in 08VRS:	«MPB»	«MPH»	«MPD»	«MPC»
	Supported by supply unit:	«-»			

The drive is constantly monitoring the effective velocity command value (sum of velocity command values at controller input) and is limiting it.

If the effective velocity command value exceeds "S-0-0091, Bipolar velocity limit value", the warning E2059 is output because for positioning tasks the lag error can be increased.

Cause	Remedy
Cyclic command value preset by control unit is incorrect or too high	Control cyclic command value and, if necessary, adjust control program
Velocity limit value parameterized too low	Check and correct parameterization of "S-0-0091, Bipolar velocity limit value"

See also Functional Description of firmware "Velocity Control"

E2059 - Attributes	Display:	E2059
	Ident N°:	E2059

9.4.24 E2061 Device overload prewarning

Allocation	Contained in 02VRS:	«MPB»	«MPH»	«MPD»	
	Contained in 03VRS:	«MPB»	«MPH»	«MPD»	
	Contained in 04VRS:	«MPB»	«MPH»	«MPD»	
	Contained in 05VRS:	«MPB»	«MPH»	«MPD»	
	Contained in 06VRS:	«MPB»	«MPH»	«MPD»	«MPC»
	Contained in 07VRS:	«MPB»	«MPH»	«MPD»	«MPC»
	Contained in 08VRS:	«MPB»	«MPH»	«MPD»	«MPC»
	Supported by supply unit:	«HMV»			

The load of the device has exceeded a signaling threshold. A warning is generated, alerting the user to reduce the load in order to avoid an overload.

Devices with digital control are monitored by a continuously running temperature model. If the thermal load approaches 100%, the continuous current limitation function is activated shortly thereafter and warning "E8057 Device overload, current limit active" is displayed.

Current limitation is accompanied a reduction in torque/force, which may lead to problems on machines and plants. For this reason, a warning is issued before such a situation may occur.

The warning sets bit 1 in "S-0-0012, Class 2 diagnostics".

For HCS, HMS, HMD

The threshold value for the overload prewarning can be set in "P-0-0441, Drive load warning threshold". If the thermal load exceeds this value, warning E2061 is issued. Meaningful values for "P-0-0441, Drive load warning threshold" are 80% to 90% to ensure a buffer before the actual thermal load (100%) is reached.

Warnings (Exxxx)

 The warning can be deactivated by setting a value in "P-0-0441, Drive load warning threshold" that exceeds 100% because, in this case, the fatal warning "E8057 Device overload, current limit active" is generated when the controller limits the output current.

 As of MPx05: When function "PWM frequency switching depending on load" has been selected (P-0-0556, bit 8="1" or P-0-0045, bit 11 and bit 7), the device is switched to the lower switching frequency in case the prewarning threshold is exceeded.

The device is switched to the higher frequency, when the load in P-0-0141 falls below an internally calculated threshold. The value of this threshold is lower than the value in parameter "P-0-0441, Drive load warning threshold".

As long as the controller is operated with the lower switching frequency, warning "E2061 Device overload prewarning" is displayed.

For HMV01.1R The threshold value for the overload prewarning is fixed to 90%. If the thermal load exceeds this value, warning E2061 is issued. This threshold cannot be set and therefore the warning cannot be deactivated!

Cause	Remedy
Inappropriate value of "P-0-0441, Drive load warning threshold"	Increase value of "P-0-0441, Drive load warning threshold" if necessary
Overload of drive (e.g., due to excessive infeed during machining or high acceleration to high speed)	Switch drive off and let it cool down. Check drive dimensioning and command value profile
Changes in mechanical system with regard to friction and moved masses	If installations have been operated for a prolonged time period, check drive conditions for changes in mechanical system

See also Functional Description of firmware "Current Limitation"

E2061 - Attributes
 Display: E2061
 Ident N°: E2061

9.4.25 E2063 Velocity command value > limit value

Allocation	Contained in 02VRS:	«MPB»	«MPH»	«MPD»	
	Contained in 03VRS:	«MPB»	«MPH»	«MPD»	
	Contained in 04VRS:	«MPB»	«MPH»	«MPD»	
	Contained in 05VRS:	«MPB»	«MPH»	«MPD»	
	Contained in 06VRS:	«MPB»	«MPH»	«MPD»	«MPC»
	Contained in 07VRS:	«MPB»	«MPH»	«MPD»	«MPC»
	Contained in 08VRS:	«MPB»	«MPH»	«MPD»	«MPC»
	Supported by supply unit:	«-»			

The drive continuously monitors the velocity command value (S-0-0036 or another parameterized command value input).

If the velocity command value exceeds the smallest parameterized velocity limit value, the lag error can be increased for positioning tasks.

Cause	Remedy
Cyclic command value preset by control unit is incorrect or too high	Check cyclic command value and, if necessary, adjust control program
Velocity limit value parameterized too low	Check and correct parameterization of "S-0-0091, Bipolar velocity limit value", "S-0-0038, Positive velocity limit value", "S-0-0039, Negative velocity limit value"

Warnings (Exxxx)

See also Functional Description of firmware "Velocity Control"

E2063 - Attributes **Display:** E2063
 Ident N°: E2063

9.4.26 E2064 Target position out of num. range

Allocation	Contained in 02VRS:	«MPB»	«MPH»	«MPD»	
	Contained in 03VRS:	«MPB»	«MPH»	«MPD»	
	Contained in 04VRS:	«-»	«-»	«-»	
	Contained in 05VRS:	«-»	«-»	«-»	
	Contained in 06VRS:	«-»	«-»	«-»	«-»
	Contained in 07VRS:	«-»	«-»	«-»	«-»
	Contained in 08VRS:	«-»	«-»	«-»	«-»
	Supported by supply unit:	«-»			

The operating mode "drive-internal interpolation" or "drive-controlled positioning" was selected and the preset target position cannot be displayed in the internal position format.

Cause	Remedy
Incorrect target position or positioning command value was preset	Check target position ("S-0-0258, Target position") or positioning command value ("S-0-0282, Positioning command value") preset by control unit (master) and, if necessary, correct control unit program
An "infinitely turning axis" is not operated in modulo format	Check content of "S-0-0076, Position data scaling type" and change to "modulo format"
Selected "S-0-0278, Maximum travel range" too small	Increase value of "S-0-0278, Maximum travel range" in order to increase position that can be displayed internally in absolute form

See also Functional Description of firmware "Drive-Controlled Positioning"

See also Functional Description of firmware "Drive-Internal Interpolation"

E2064 - Attributes **Display:** E2064
 Ident N°: E2064

9.4.27 E2069 Holding brake torque too low

Allocation	Contained in 02VRS:	«MPB»	«MPH»	«MPD»	
	Contained in 03VRS:	«MPB»	«MPH»	«MPD»	
	Contained in 04VRS:	«MPB»	«MPH»	«MPD»	
	Contained in 05VRS:	«MPB»	«MPH»	«MPD»	
	Contained in 06VRS:	«MPB»	«MPH»	«MPD»	«MPC»
	Contained in 07VRS:	«MPB»	«MPH»	«MPD»	«MPC»
	Contained in 08VRS:	«MPB»	«MPH»	«MPD»	«MPC»
	Supported by supply unit:	«-»			

When drive enable was switched off, the motor moved during the automatic check of the holding brake torque (can be activated via "P-0-0525, Holding brake control word"). The motor holding brake therefore no longer provides the required holding torque (see also "P-0-0547, Test torque with holding brake applied").



The result of the brake check is displayed in "P-0-0539, Holding brake status word".

Warnings (Exxxx)

Cause	Remedy
Due to storage, brake is covered by an oxide layer - or - Brake is wetted with oil or grease	If warning occurs when drive enable is switched off, start command "P-0-0544, C3900 Command Holding brake resurfacing" in order to resurface brake. Afterwards brake should be able to provide full torque again
Brake is worn (see "service life of brake" in Project Planning Manual of motor)	If holding torque still is not reached after repeated start of command "P-0-0544, C3900 Command Holding brake resurfacing", motor holding brake or entire motor must be replaced
Wiring or control error of brake (hardware defect on control section)	Check wiring and connection of brake (incl. brake relay). If holding brake control in controller (e.g. relay) is defective, entire drive controller or control section has to be replaced

See also Functional Description of firmware "Motor Holding Brake"

E2069 - Attributes Display: E2069
 Ident N°: E2069

9.4.28 E2070 Acceleration limit active

Allocation	Contained in 02VRS:	«-»	«-»	«-»	
	Contained in 03VRS:	«-»	«-»	«-»	
	Contained in 04VRS:	«MPB»	«MPH»	«MPD»	
	Contained in 05VRS:	«MPB»	«MPH»	«MPD»	
	Contained in 06VRS:	«MPB»	«MPH»	«MPD»	«MPC»
	Contained in 07VRS:	«MPB»	«MPH»	«MPD»	«MPC»
	Contained in 08VRS:	«MPB»	«MPH»	«MPD»	«MPC»
	Supported by supply unit:	«-»			

The acceleration in the velocity loop is limited to the value of "S-0-0138, Bipolar acceleration limit value".



As of MPx05: The acceleration monitoring can be switched off by inputting "0" in "S-0-0138, Bipolar acceleration limit value".

Cause	Remedy
Value in "S-0-0138, Bipolar acceleration limit value" too low	Check and, if necessary, correct parameterization of "S-0-0138, Bipolar acceleration limit value"
Incorrect command value set by control unit	Contact control unit manufacturer or programmer
Preset acceleration value was greater than value parameterized in "S-0-0138, Bipolar acceleration limit value"	Reduce acceleration value used <ul style="list-style-type: none"> • S-0-0042, Homing acceleration • S-0-0260, Positioning acceleration • P-0-0057, Return acceleration • P-0-1201, Ramp 1 pitch • P-0-1203, Ramp 2 pitch • P-0-1211, Deceleration ramp 1 • P-0-1213, Deceleration ramp 2

E2070 - Attributes Display: E2070
 Ident N°: E2070

Warnings (Exxxx)

9.4.29 E2074 Encoder 1: Encoder signals disturbed

Allocation	Contained in 02VRS:	«MPB»	«MPH»	«MPD»	
	Contained in 03VRS:	«MPB»	«MPH»	«MPD»	
	Contained in 04VRS:	«MPB»	«MPH»	«MPD»	
	Contained in 05VRS:	«MPB»	«MPH»	«MPD»	
	Contained in 06VRS:	«MPB»	«MPH»	«MPD»	«MPC»
	Contained in 07VRS:	«MPB»	«MPH»	«MPD»	«MPC»
	Contained in 08VRS:	«MPB»	«MPH»	«MPD»	«MPC»
	Supported by supply unit:	«-»			

The hardware checks the signals of the measuring system (encoder 1) for inadmissible signal dips. If a signal (e.g., sin or cos) leaves the thresholds monitored by the hardware, the warning E2074 is generated.

For absolute measuring systems (EnDat2.1, HIPERFACE®), the position generation via the incremental track signals (SIN/COS) is monitored by cyclic comparison to the absolute position of the encoder. This allows detecting disturbances of the analog encoder signals.

In the case of major failures or several signal dips in series, the error "F8022 Enc. 1: Enc. signals incorr." is generated and the drive is shut down. The warning E2074 therefore points at disturbed encoder signals before a breakdown occurs.



The warning E2074 is only cleared by reinitialization of the encoder position; i.e. it is necessary to switch to communication phase 2.

Cause	Remedy
Defective encoder cable or cable shielding	Check cable to measuring system and replace it, if necessary
Measuring system defective	Check measuring system and replace it, if necessary
Faulty mounting of measuring head in the case of linear measuring systems	Check mounting of measuring head and correct it, if necessary
Measuring system dirty	Clean or replace measuring system
Hardware defect on control section of drive	Replace control section or entire drive controller



Only Rexroth service engineers or especially trained users are allowed to replace the control section. The replacement of the entire drive controller is described in the Project Planning Manual for the power section.

E2074 - Attributes	Display:	E2074
	Ident N°:	E2074

9.4.30 E2075 Encoder 2: Encoder signals disturbed

Allocation	Contained in 02VRS:	«MPB»	«MPH»	«MPD»	
	Contained in 03VRS:	«MPB»	«MPH»	«MPD»	
	Contained in 04VRS:	«MPB»	«MPH»	«MPD»	
	Contained in 05VRS:	«MPB»	«MPH»	«MPD»	
	Contained in 06VRS:	«MPB»	«MPH»	«MPD»	«MPC»
	Contained in 07VRS:	«MPB»	«MPH»	«MPD»	«MPC»
	Contained in 08VRS:	«MPB»	«MPH»	«MPD»	«MPC»
	Supported by supply unit:	«-»			

Warnings (Exxxx)

The hardware checks the signals of the measuring system (encoder 2) for inadmissible signal dips. If a signal (e.g., sin or cos) leaves the thresholds monitored by the hardware, the warning E2075 is generated.

For absolute measuring systems (EnDat2.1, HIPERFACE®), the position generation via the incremental track signals (SIN/COS) is monitored by cyclic comparison to the absolute position of the encoder. This allows detecting disturbances of the analog encoder signals.

In the case of major failures or several signal dips in series, the error "F2042 Encoder 2: Encoder signals incorrect" is generated and the drive is shut down. The warning E2075 therefore points at disturbed encoder signals before a breakdown occurs.



The warning E2075 is only cleared by reinitialization of the encoder position; i.e. it is necessary to switch to communication phase 2.

Cause	Remedy
Defective encoder cable or cable shielding	Check cable to measuring system and replace it, if necessary
Measuring system defective	Check measuring system and replace it, if necessary
Faulty mounting of measuring head in the case of linear measuring systems	Check mounting of measuring head and correct it, if necessary
Measuring system dirty	Clean or replace measuring system
Hardware defect on control section of drive	Replace control section or entire drive controller



Only Rexroth service engineers or especially trained users are allowed to replace the control section. The replacement of the entire drive controller is described in the Project Planning Manual for the power section.

E2075 - Attributes Display: E2075
 Ident N°: E2075

9.4.31 E2076 Measuring encoder: Encoder signals disturbed

Allocation	Contained in 02VRS:	«MPB»	«MPH»	«MPD»	
	Contained in 03VRS:	«MPB»	«MPH»	«MPD»	
	Contained in 04VRS:	«MPB»	«MPH»	«MPD»	
	Contained in 05VRS:	«MPB»	«MPH»	«MPD»	
	Contained in 06VRS:	«MPB»	«MPH»	«MPD»	«MPC»
	Contained in 07VRS:	«MPB»	«MPH»	«MPD»	«MPC»
	Contained in 08VRS:	«MPB»	«MPH»	«MPD»	«MPC»
	Supported by supply unit:	«-»			

The hardware checks the signals of the measuring encoder for inadmissible signal dips. If a signal (e.g., sin or cos) leaves the thresholds monitored by the hardware, the warning E2076 is generated.

For absolute measuring systems (EnDat2.1, HIPERFACE®), the position generation via the incremental track signals (SIN/COS) is monitored by cyclic comparison to the absolute position of the encoder. This allows detecting disturbances of the analog encoder signals.

In the case of major failures or several signal dips in series, the error "F2043 Measuring encoder: Encoder signals incorrect" is generated and the drive is

Warnings (Exxxx)

shut down. The warning E2076 therefore points at disturbed encoder signals before a breakdown occurs.



The warning E2076 is only cleared by reinitialization of the encoder position; i.e. it is necessary to switch to communication phase 2.

Cause	Remedy
Defective encoder cable or cable shielding	Check cable to measuring system and replace it, if necessary
Measuring system defective	Check measuring system and replace it, if necessary
Faulty mounting of measuring head in the case of linear measuring systems	Check mounting of measuring head and correct it, if necessary
Measuring system dirty	Clean or replace measuring system
Hardware defect on control section of drive	Replace control section or entire drive controller



Only Rexroth service engineers or especially trained users are allowed to replace the control section. The replacement of the entire drive controller is described in the Project Planning Manual for the power section.

E2076 - Attributes	Display:	E2076
	Ident N°:	E2076

9.4.32 E2077 Absolute encoder monitoring, motor encoder (encoder alarm)

Allocation	Contained in 02VRS:	«-»	«-»	«-»	
	Contained in 03VRS:	«MPB»	«MPH»	«MPD»	
	Contained in 04VRS:	«-»	«-»	«-»	
	Contained in 05VRS:	«MPB»	«MPH»	«MPD»	
	Contained in 06VRS:	«MPB»	«MPH»	«MPD»	«MPC»
	Contained in 07VRS:	«MPB»	«MPH»	«MPD»	«MPC»
	Contained in 08VRS:	«MPB»	«MPH»	«MPD»	«MPC»
	Supported by supply unit:	«-»			

The signals of an absolute measuring system (EnDat2.x) are monitored in the encoder.

In the drive controller, cyclic transmission of the absolute position is carried out. The error bit of the encoder is transmitted, too. The drive controller cyclically checks this error bit and outputs the warning E2077 when an error of the absolute position occurs.



The warning E2077 is only cleared by reinitialization of the encoder position; i.e. it is necessary to switch to communication phase 2.

Cause	Remedy
Measuring system defective	Check measuring system and replace it, if necessary
Faulty mounting of measuring head in the case of linear measuring systems	Check mounting of measuring head and correct it, if necessary
Measuring system dirty	Clean or replace measuring system

Warnings (Exxxx)

Cause	Remedy
Measuring system defective	Check measuring system and replace it, if necessary
Faulty mounting of measuring head in the case of linear measuring systems	Check mounting of measuring head and correct it, if necessary
Measuring system dirty	Clean or replace measuring system

E2079 - Attributes Display: E2079
 Ident N°: E2079

9.4.35 E2086 Prewarning supply module overload

Allocation	Contained in 02VRS:	«MPB»	«MPH»	«MPD»	
	Contained in 03VRS:	«MPB»	«MPH»	«MPD»	
	Contained in 04VRS:	«MPB»	«MPH»	«MPD»	
	Contained in 05VRS:	«MPB»	«MPH»	«MPD»	
	Contained in 06VRS:	«MPB»	«MPH»	«MPD»	«MPC»
	Contained in 07VRS:	«MPB»	«MPH»	«MPD»	«MPC»
	Contained in 08VRS:	«MPB»	«MPH»	«MPD»	«MPC»
	Supported by supply unit:	«-»			

The supply signals a warning regarding imminent overload via the module bus. The warning is displayed at the drive controllers and can be evaluated by the control master via the master communication. If there is no relief, the module bus message "error supply module" and power off (F2086) can occur.

Cause	Remedy
Imminent overload of power supply	Reduce required power by lower infeed velocity of tools. Check dimensioning of supply
Max. energy absorption capacity of braking resistor almost reached	Check dimensioning of braking resistor and, if necessary, increase dimensioning

See also Functional Description of firmware "Power Supply"

E2086 - Attributes Display: E2086
 Ident N°: E2086

9.4.36 E2092 Internal synchronization defective

Allocation	Contained in 02VRS:	«-»	«-»	«-»	
	Contained in 03VRS:	«-»	«-»	«-»	
	Contained in 04VRS:	«MPB»	«MPH»	«MPD»	
	Contained in 05VRS:	«MPB»	«MPH»	«MPD»	
	Contained in 06VRS:	«MPB»	«MPH»	«MPD»	«MPC»
	Contained in 07VRS:	«MPB»	«MPH»	«MPD»	«MPC»
	Contained in 08VRS:	«MPB»	«MPH»	«MPD»	«MPC»
	Supported by supply unit:	«-»			

The drive is told by the NC cycle time in which intervals new cyclic command values must be received and have been processed. The warning E2092 is generated, when the parameterized processing clock ["S-0-0001, NC cycle time (TNcyc)"] differs from the effective processing clock of the cyclic command values.

Warnings (Exxxx)

9.4.38 E2101 Acceleration of master axis generator is zero

Allocation	Contained in 02VRS:	«-»	«-»	«-»	
	Contained in 03VRS:	«-»	«-»	«-»	
	Contained in 04VRS:	«MPB»	«MPH»	«MPD»	
	Contained in 05VRS:	«-»	«-»	«-»	
	Contained in 06VRS:	«-»	«-»	«-»	«-»
	Contained in 07VRS:	«-»	«-»	«-»	«-»
	Contained in 08VRS:	«-»	«-»	«-»	«-»
	Supported by supply unit:	«-»			

Cause	Remedy
Preset positioning acceleration of master axis generator is "0"	Set positioning acceleration of master axis generator unequal "0" in "P-0-0771, Virtual master axis, positioning acceleration"

E2101 - Attributes Display: E2101
 Ident N°: E2101

9.4.39 E2140 CCD error at node

Allocation	Contained in 02VRS:	«-»	«-»	«-»	
	Contained in 03VRS:	«-»	«-»	«-»	
	Contained in 04VRS:	«-»	«MPH»	«-»	
	Contained in 05VRS:	«-»	«MPH»	«-»	
	Contained in 06VRS:	«-»	«-»	«-»	«MPC»
	Contained in 07VRS:	«-»	«-»	«-»	«MPC»
	Contained in 08VRS:	«-»	«-»	«-»	«MPC»
	Supported by supply unit:	«-»			

The warning is generated,

1. when the CCD group is in phase 4,
2. at least the simple error reaction has been activated via P-0-1600 and
3. at least one CCD node signals an error of class 1 diagnostics.

Cause	Remedy
In a CCD slave or in CCD master, an error of class 1 diagnostics has occurred	Remove error in CCD slave or CCD master
In a CCD slave or in CCD master, a motion function block with faulty parameters was called in drive-integrated PLC (IndraMotion MLD-M) [see also "P-0-1367, PLC configuration", bit7]	Remove error in PLC program

See also Functional Description of firmware "Cross Communication (CCD)"

E2140 - Attributes Display: E2140
 Ident N°: E2140

9.4.40 E2270 Analog input 1 or 2, wire break

Allocation	Contained in 02VRS:	«MPB»	«-»	«-»	
	Contained in 03VRS:	«MPB»	«-»	«-»	
	Contained in 04VRS:	«MPB»	«-»	«-»	
	Contained in 05VRS:	«MPB»	«-»	«-»	
	Contained in 06VRS:	«MPB»	«-»	«-»	«-»
	Contained in 07VRS:	«MPB»	«-»	«-»	«-»
	Contained in 08VRS:	«MPB»	«-»	«-»	«-»
	Supported by supply unit:	«-»			

Conditions under which this warning is triggered:

Warnings (Exxxx)

- The wire break monitor was activated in "P-0-0218, Analog input, control parameter" (by the setting for the measuring range of the analog inputs) and
- a setting in "P-0-0218, Analog input, control parameter" causes a warning to be generated when the input value has fallen below the input value at analog input 1 or 2 and
- the current/voltage value at analog input 1 or 2 is lower than the minimum value of the measuring range.

The warning persists until the condition has been fulfilled.



The value range of the voltage or current source that is connected to the analog input should be limited to the allowed value range of the analog input.

Cause	Remedy
Input value at analog input 1 or 2 is lower than minimum value of voltage measuring range (setting "voltage signals" in "P-0-0218, Analog input, control parameter")	Check wiring of analog input, reestablish contact to voltage source, if necessary - or - Check value range of voltage source
Input value at analog input 1 or 2 is lower than minimum value of current measuring range (setting "current signals" in "P-0-0218, Analog input, control parameter")	Check wiring of analog input, reestablish contact to current source, if necessary - or - Check value range of current source



This warning can only be displayed at a controller containing a CSB01.1N-FC-... (BASIC OPENLOOP) control section.

E2270 - Attributes Display: E2270
 Ident N°: E2270

9.4.41 E2802 HW control of braking resistor

Allocation	Contained in 02VRS:	«MPB»	«MPH»	«MPD»	
	Contained in 03VRS:	«MPB»	«MPH»	«MPD»	
	Contained in 04VRS:	«MPB»	«MPH»	«MPD»	
	Contained in 05VRS:	«MPB»	«MPH»	«MPD»	
	Contained in 06VRS:	«MPB»	«MPH»	«MPD»	«MPC»
	Contained in 07VRS:	«MPB»	«MPH»	«MPD»	«MPC»
	Contained in 08VRS:	«MPB»	«MPH»	«MPD»	«MPC»
	Supported by supply unit:	«-»			

During the braking process the increasing DC bus voltage is reduced by switching on the braking resistor. But when the regenerated braking power is too high the DC bus voltage keeps increasing. The warning E2802 is generated when the protective hardware circuit switches on the braking resistor in the case of high voltages (>900 V).

Cause	Remedy
DC bus voltage >900 V due to increased regenerated braking energy	Check drive dimensioning and, if necessary, use additional capacitance
Braking resistor defective or not correctly connected	Check function of braking resistor (incl. cabling and connection)
Hardware defect in brake control	Replace power section or entire drive controller

Warnings (Exxxx)



Only Rexroth service engineers or especially trained users are allowed to replace the power section. The replacement of the entire drive controller is described in the Project Planning Manual for the power section.

See also Functional Description of firmware "Power Supply"

E2802 - Attributes
Display: E2802
Ident N°: E2802

9.4.42 E2810 Drive system not ready for operation

Allocation	Contained in 02VRS:	«MPB»	«MPH»	«MPD»	
	Contained in 03VRS:	«MPB»	«MPH»	«MPD»	
	Contained in 04VRS:	«MPB»	«MPH»	«MPD»	
	Contained in 05VRS:	«MPB»	«MPH»	«MPD»	
	Contained in 06VRS:	«MPB»	«MPH»	«MPD»	«MPC»
	Contained in 07VRS:	«MPB»	«MPH»	«MPD»	«MPC»
	Contained in 08VRS:	«MPB»	«MPH»	«MPD»	«MPC»
	Supported by supply unit:	«HMV»			

One or several components of a "drive system" (devices interconnected via direct voltage DC bus and module bus) signal an error via the module bus (Fxxxx) with the supply unit not yet ready for power output.

Power on is impossible in this case, the supply unit or the converter signal E2810 on the display.

Cause	Remedy
Error message of one or several components of a drive system	Identify component/components which signals/signal an error. Remove cause of error at component/components

See also Functional Description of firmware "Power Supply"

E2810 - Attributes
Display: E2810
Ident N°: E2810

9.4.43 E2814 Undervoltage in mains

Allocation	Contained in 02VRS:	«MPB»	«MPH»	«MPD»	
	Contained in 03VRS:	«MPB»	«MPH»	«MPD»	
	Contained in 04VRS:	«MPB»	«MPH»	«MPD»	
	Contained in 05VRS:	«MPB»	«MPH»	«MPD»	
	Contained in 06VRS:	«MPB»	«MPH»	«MPD»	«MPC»
	Contained in 07VRS:	«MPB»	«MPH»	«MPD»	«MPC»
	Contained in 08VRS:	«MPB»	«MPH»	«MPD»	«MPC»
	Supported by supply unit:	«-»			

The crest value of the mains voltage during operation has fallen below the parameterized threshold value. The threshold value can be individually set by the user via "P-0-0810, Minimum mains crest value".

Cause	Remedy
Mains voltage falls under load	Check dimensioning of mains connection, increase feed wire cross section or use matching transformer, if necessary
Mains voltage too low at power on	Use matching transformer

See also Functional Description of firmware "Power Supply"

E2814 - Attributes
Display: E2814
Ident N°: E2814

9.4.44 E2816 Undervoltage in power section

Allocation	Contained in 02VRS:	«MPB»	«MPH»	«MPD»	
	Contained in 03VRS:	«MPB»	«MPH»	«MPD»	
	Contained in 04VRS:	«MPB»	«MPH»	«MPD»	
	Contained in 05VRS:	«MPB»	«MPH»	«MPD»	
	Contained in 06VRS:	«MPB»	«MPH»	«MPD»	«MPC»
	Contained in 07VRS:	«MPB»	«MPH»	«MPD»	«MPC»
	Contained in 08VRS:	«MPB»	«MPH»	«MPD»	«MPC»
	Supported by supply unit:	«-»			

The warning E2816 is generated with the respective setting in "P-0-0118, Power supply, configuration" when the DC bus voltage in operation falls below the values parameterized in "P-0-0114, Undervoltage threshold".



The parameter "P-0-0114, Undervoltage threshold" is preset with a default value and, if required, can be changed by the user.

Cause	Remedy
DC bus voltage drops due to temporary overload	Check drive dimensioning incl. devices connected at DC bus
Required acceleration currents are too high	Reduce command acceleration by adjusting travel profile
Faulty mains connection (e.g. loose contact)	Check mains connection
"P-0-0114, Undervoltage threshold" has not been adjusted to conditions in mains	Check and, if necessary, correct content of "P-0-0114, Undervoltage threshold"

See also Functional Description of firmware "Power Supply"

E2816 - Attributes	Display:	E2816
	Ident N°:	E2816

9.4.45 E2818 Phase failure

Allocation	Contained in 02VRS:	«-»	«-»	«-»	
	Contained in 03VRS:	«-»	«-»	«-»	
	Contained in 04VRS:	«-»	«-»	«-»	
	Contained in 05VRS:	«-»	«-»	«-»	
	Contained in 06VRS:	«-»	«-»	«-»	«-»
	Contained in 07VRS:	«-»	«-»	«-»	«-»
	Contained in 08VRS:	«-»	«-»	«-»	«-»
	Supported by supply unit:	«HMV»			

A **single-phase** mains failure was detected. Power is not switched off unless undervoltage occurs in the DC bus (F2026).



When the phase failure lasts for a longer time, the error "F2818 Phase failure" is generated.

Cause	Remedy
No mains voltage available	Check mains voltage and mains connection
Mains circuit breaker defective	Replace mains circuit breaker
Incorrect wiring	Check and correct wiring

E2818 - Attributes	Display:	E2818
	Ident N°:	E2818

Warnings (Exxxx)

9.4.46 E2819 Mains failure

Allocation	Contained in 02VRS:	«MPB»	«MPH»	«MPD»	
	Contained in 03VRS:	«MPB»	«MPH»	«MPD»	
	Contained in 04VRS:	«MPB»	«MPH»	«MPD»	
	Contained in 05VRS:	«MPB»	«MPH»	«MPD»	
	Contained in 06VRS:	«MPB»	«MPH»	«MPD»	«MPC»
	Contained in 07VRS:	«MPB»	«MPH»	«MPD»	«MPC»
	Contained in 08VRS:	«MPB»	«MPH»	«MPD»	«MPC»
	Supported by supply unit:	«HMV»			

A two-phase or three-phase mains failure was detected. Power is not switched off unless undervoltage occurs in the DC bus (E2026).

Cause	Remedy
No mains voltage available	Check mains voltage and mains connection
Mains circuit breaker defective	Replace mains circuit breaker
Incorrect wiring	Check and correct wiring

E2819 - Attributes Display: E2819
 Ident N°: E2819

9.4.47 E2820 Braking resistor overload prewarning

Allocation	Contained in 02VRS:	«MPB»	«MPH»	«MPD»	
	Contained in 03VRS:	«MPB»	«MPH»	«MPD»	
	Contained in 04VRS:	«MPB»	«MPH»	«MPD»	
	Contained in 05VRS:	«MPB»	«MPH»	«MPD»	
	Contained in 06VRS:	«MPB»	«MPH»	«MPD»	«MPC»
	Contained in 07VRS:	«MPB»	«MPH»	«MPD»	«MPC»
	Contained in 08VRS:	«MPB»	«MPH»	«MPD»	«MPC»
	Supported by supply unit:	«HMV»			

A temperature model taking the working power and the maximum energy consumption of the braking resistor into account is calculated for the thermal load of the braking resistance. If the thermal load reaches the warning threshold, this warning is issued and bit 1 is set in "S-0-0012, Class 2 diagnostics".

Up to MPx07V12: The warning threshold is fixed to 90%.

As of MPx07V14: The warning threshold can be defined by parameter "P-0-0469, Prewarning threshold of therm. load of braking resistor".

Cause	Remedy
Allowed deceleration of connected drives too high	Reduce deceleration of connected drives
Energy consumption capacity of braking resistor is almost exhausted	Switch power off with a delay in case of OFF or E-STOP (for regenerative supply)
Regenerated energy in machining cycle is too high	Increase cycle time or reduce maximum drive speed of application
Braking resistor connection is interrupted	Check wiring of external braking resistor
Continuous regenerative power and/or rotary drive energy is too high	Check dimensioning of braking resistor; increase dimensioning if necessary

E2820 - Attributes Display: E2820
 Ident N°: E2820

9.4.48 E2829 Not ready for power on

Allocation	Contained in 02VRS:	«MPB»	«MPH»	«MPD»	
	Contained in 03VRS:	«MPB»	«MPH»	«MPD»	
	Contained in 04VRS:	«MPB»	«MPH»	«MPD»	
	Contained in 05VRS:	«MPB»	«MPH»	«MPD»	
	Contained in 06VRS:	«MPB»	«MPH»	«MPD»	«MPC»
	Contained in 07VRS:	«MPB»	«MPH»	«MPD»	«MPC»
	Contained in 08VRS:	«MPB»	«MPH»	«MPD»	«MPC»
	Supported by supply unit:	«-»			

The mains voltage for power supply cannot yet be switched on for the converter; the device is not yet ready for charging the DC bus capacitors.

Cause	Remedy
Resistors for charging DC bus capacitors still are thermally loaded due to last charging process	Wait until converter clears warning E2829

E2829 - Attributes	Display:	E2829
	Ident N°:	E2829

10 Diagnostic Command Messages

10.1 Commands

10.1.1 C0100 Communication phase 3 transition check

Allocation	Contained in 02VRS:	«MPB»	«MPH»	«MPD»	
	Contained in 03VRS:	«MPB»	«MPH»	«MPD»	
	Contained in 04VRS:	«MPB»	«MPH»	«MPD»	
	Contained in 05VRS:	«MPB»	«MPH»	«MPD»	
	Contained in 06VRS:	«MPB»	«MPH»	«MPD»	«MPC»
	Contained in 07VRS:	«MPB»	«MPH»	«MPD»	«MPC»
	Contained in 08VRS:	«MPB»	«MPH»	«MPD»	«MPC»
	Supported by supply unit:	«HMV»			

The "S-0-0127, C0100 Communication phase 3 transition check" command was activated.

C0100 - Attributes	Display:	C01
	Ident N°:	C0100

10.1.2 C0200 Exit parameterization level procedure command

Allocation	Contained in 02VRS:	«MPB»	«MPH»	«MPD»	
	Contained in 03VRS:	«MPB»	«MPH»	«MPD»	
	Contained in 04VRS:	«MPB»	«MPH»	«MPD»	
	Contained in 05VRS:	«MPB»	«MPH»	«MPD»	
	Contained in 06VRS:	«MPB»	«MPH»	«MPD»	«MPC»
	Contained in 07VRS:	«MPB»	«MPH»	«MPD»	«MPC»
	Contained in 08VRS:	«MPB»	«MPH»	«MPD»	«MPC»
	Supported by supply unit:	«HMV»			



In the firmware versions 02VRS and 03VRS, the name of the command is "C0200 Communication phase 4 transition check".

02VRS / 03VRS The command "S-0-0128, C0200 Communication phase 4 transition check" has been activated.

As of 04VRS The command "S-0-0422, C0200 Exit parameterization level procedure command" has been activated.

C0200 - Attributes	Display:	C02
	Ident N°:	C0200

10.1.3 C0300 Set absolute position procedure command

Allocation	Contained in 02VRS:	«MPB»	«MPH»	«MPD»	
	Contained in 03VRS:	«MPB»	«MPH»	«MPD»	
	Contained in 04VRS:	«MPB»	«MPH»	«MPD»	
	Contained in 05VRS:	«MPB»	«MPH»	«MPD»	
	Contained in 06VRS:	«MPB»	«MPH»	«MPD»	«MPC»
	Contained in 07VRS:	«MPB»	«MPH»	«MPD»	«MPC»
	Contained in 08VRS:	«MPB»	«MPH»	«MPD»	«MPC»
	Supported by supply unit:	«-»			

The command for setting the absolute measuring ("P-0-0012, C0300 Command Set absolute measuring") was activated.

See also Functional Description of firmware "Set Absolute Measuring"

C0300 - Attributes	Display:	C03
	Ident N°:	C0300

Diagnostic Command Messages

10.1.4 C0400 Activate parameterization level 1 procedure command

Allocation	Contained in 02VRS:	«MPB»	«MPH»	«MPD»	
	Contained in 03VRS:	«MPB»	«MPH»	«MPD»	
	Contained in 04VRS:	«MPB»	«MPH»	«MPD»	
	Contained in 05VRS:	«MPB»	«MPH»	«MPD»	
	Contained in 06VRS:	«MPB»	«MPH»	«MPD»	«MPC»
	Contained in 07VRS:	«MPB»	«MPH»	«MPD»	«MPC»
	Contained in 08VRS:	«MPB»	«MPH»	«MPD»	«MPC»
	Supported by supply unit:	«HMV»			

02VRS / 03VRS The command for switching to the parameter mode was started via parameter "P-0-4023, C0400 Communication phase 2 transition".



This command has to be carried out before editing parameters that can only be written in the parameter mode.

As of 04VRS The command for switching to the parameter mode was started via parameter "S-0-0420, C0400 Activate parameterization level 1 procedure command".

C0400 - Attributes Display: C04
Ident N°: C0400

10.1.5 C0500 Reset class 1 diagnostics, error reset

Allocation	Contained in 02VRS:	«MPB»	«MPH»	«MPD»	
	Contained in 03VRS:	«MPB»	«MPH»	«MPD»	
	Contained in 04VRS:	«MPB»	«MPH»	«MPD»	
	Contained in 05VRS:	«MPB»	«MPH»	«MPD»	
	Contained in 06VRS:	«MPB»	«MPH»	«MPD»	«MPC»
	Contained in 07VRS:	«MPB»	«MPH»	«MPD»	«MPC»
	Contained in 08VRS:	«MPB»	«MPH»	«MPD»	«MPC»
	Supported by supply unit:	«HMV»			

The command for clearing errors, "S-0-0099, C0500 Reset class 1 diagnostics", was activated. All drive-internal errors are cleared.



Only those errors can be cleared that were removed! Errors that are still present after clearing will cause the error message to be generated again.

⚠ CAUTION

Damage to the internal memory (flash) caused by too many write accesses!

⇒ During the execution of this command, data are written to the internal memory (flash). As each flash only allows a limited number of write accesses before its memory locations are destroyed, you should make sure that such write accesses won't be carried out too often.

C0500 - Attributes Display: C05
Ident N°: C0500

10.1.6 C0600 Drive-controlled homing procedure command

Allocation	Contained in 02VRS:	«MPB»	«MPH»	«MPD»	
	Contained in 03VRS:	«MPB»	«MPH»	«MPD»	
	Contained in 04VRS:	«MPB»	«MPH»	«MPD»	
	Contained in 05VRS:	«MPB»	«MPH»	«MPD»	
	Contained in 06VRS:	«MPB»	«MPH»	«MPD»	«MPC»
	Contained in 07VRS:	«MPB»	«MPH»	«MPD»	«MPC»
	Contained in 08VRS:	«MPB»	«MPH»	«MPD»	«MPC»
	Supported by supply unit:	«->»			

The command for drive-controlled homing, "S-0-0148, C0600 Drive-controlled homing procedure command", was activated.

See also Functional Description of firmware "Drive-Controlled Homing"

C0600 - Attributes
 Display: C06
 Ident N°: C0600

10.1.7 C0700 Load defaults proced. command (motor-spec. controller val.)

Allocation	Contained in 02VRS:	«MPB»	«MPH»	«MPD»	
	Contained in 03VRS:	«MPB»	«MPH»	«MPD»	
	Contained in 04VRS:	«MPB»	«MPH»	«MPD»	
	Contained in 05VRS:	«MPB»	«MPH»	«MPD»	
	Contained in 06VRS:	«MPB»	«MPH»	«MPD»	«MPC»
	Contained in 07VRS:	«MPB»	«MPH»	«MPD»	«MPC»
	Contained in 08VRS:	«MPB»	«MPH»	«MPD»	«MPC»
	Supported by supply unit:	«-»			



Up to MPx07, the name of this command was "C0720 Load defaults procedure com. (load controller param.)".

The message "C07_0" on the display of the drive controller shows that the command "C0700 Load defaults proced. command (motor-spec. controller val.)" was activated.

The command can be started as follows:

- Via parameter "S-0-0262, C07_x Load defaults procedure command" or
- Via the control panel of the drive controller or
- By starting the command "S-0-0099, C0500 Reset class 1 diagnostics" when the drive controller displays "RL". ("RL" occurs if parameters "S-0-0141, Motor type" and "P-0-2141, Motor type, encoder memory" are different.)



With the parameter S-0-0262, it is possible to start other commands. In parameter "P-0-4090, Configuration for loading default values", it is possible to set which commands is started.

Command "C0700 Load defaults proced. command (motor-spec. controller val.)" can only be executed for Rexroth motors with motor encoder data memory (e.g. motors of the MHD, MKD and MKE lines). With these motors, the controller parameters are loaded from the motor encoder data memory to the drive controller and some controller parameters are set to their default values.

NOTICE

Command "C0700 Load defaults proced. command (motor-spec. controller val.)" overwrites user-defined controller settings!

Only use this command if you want to load standard controller parameter values. For saving and then loading user-defined parameter values, there are specific commands available.

Diagnostic Command Messages

NOTICE

Damage to the internal memory (flash) caused by too many write accesses!

During the execution of this command, data are written to the internal memory (flash). This memory, however, only allows a limited number of write accesses. For this reason, you should make sure that such write accesses are not carried out too often (a maximum of approx. 100,000 writing cycles).

See also Functional Description of firmware "Loading, Storing and Saving Parameters"

See also Functional Description of firmware "Control Panels of the IndraDrive Controllers"

C0700 - Attributes
Display: C07_0
Ident N°: C0700

10.1.8 C0720 Load defaults procedure command (safety technology)

Allocation	Contained in 02VRS:	«MPB»	«MPH»	«MPD»	
	Contained in 03VRS:	«MPB»	«MPH»	«MPD»	
	Contained in 04VRS:	«MPB»	«MPH»	«MPD»	
	Contained in 05VRS:	«MPB»	«MPH»	«MPD»	
	Contained in 06VRS:	«MPB»	«MPH»	«MPD»	«MPC»
	Contained in 07VRS:	«MPB»	«MPH»	«MPD»	«MPC»
	Contained in 08VRS:	«MPB»	«MPH»	«MPD»	«MPC»
	Supported by supply unit:	«-»			



Up to MPx07, the name of this command was "C0720 Load def. proc. com. (load def. pr. for safety techn.)".

Message "C07_4" on the display of the drive controller shows that command "C0740 Load defaults procedure command (safety technology)" was activated.

The command can be started as follows:

1. Enter value "0x00A5" in parameter "P-0-4090, Configuration for loading default values".
2. Start "S-0-0262, C07_x Load defaults procedure command".



With the parameter S-0-0262, it is possible to start other commands. In parameter "P-0-4090, Configuration for loading default values", it is possible to set which commands is started.

CAUTION

Command "C0720 Load defaults procedure command (safety technology)" deactivates the safety technology and overwrites user-defined safety technology settings!

Use this command only if you want to commission a new safety technology.

C0720 - Attributes
Display: C07_2
Ident N°: C0720

10.1.9 C0730 Load defaults procedure command (MLD)

Allocation	Contained in 02VRS:	«-»	«-»	«-»	
	Contained in 03VRS:	«-»	«-»	«-»	
	Contained in 04VRS:	«MPB»	«MPH»	«-»	
	Contained in 05VRS:	«MPB»	«MPH»	«-»	
	Contained in 06VRS:	«MPB»	«MPH»	«-»	«MPC»
	Contained in 07VRS:	«MPB»	«MPH»	«-»	«MPC»
	Contained in 08VRS:	«MPB»	«MPH»	«-»	«MPC»
	Supported by supply unit:	«-»			



Up to MPx07, the name of this command was "C0730 Load def. proc. com. (load defaults procedure for PLC)".

Message "C07_3" on the display of the drive controller shows that command "C0730 Load defaults procedure command (MLD)" was activated.

The command can be started as follows:

1. Enter value "0x0002" in parameter "P-0-4090, Configuration for loading default values".
2. Start "S-0-0262, C07_x Load defaults procedure command".



With the parameter S-0-0262, it is possible to start other commands. In parameter "P-0-4090, Configuration for loading default values", it is possible to set which commands is started.

CAUTION

Command "C0730 Load defaults procedure command (MLD)" deactivates the drive PLC and overwrites user-defined PLC settings!

Use this command only if you want to completely erase the PLC program and its parameters without programming system.

C0730 - Attributes	Display:	C07_3
	Ident N°:	C0730

10.1.10 C0740 Command Activate field bus profile settings

Allocation	Contained in 02VRS:	«-»	«-»	«-»	
	Contained in 03VRS:	«-»	«-»	«-»	
	Contained in 04VRS:	«-»	«-»	«-»	
	Contained in 05VRS:	«-»	«-»	«-»	
	Contained in 06VRS:	«-»	«-»	«-»	«-»
	Contained in 07VRS:	«-»	«-»	«-»	«-»
	Contained in 08VRS:	«MPB»	«MPH»	«MPD»	«MPC»
	Supported by supply unit:	«-»			

The message "C07_4" on the display of the drive controller shows that the command "C0740 Command Activate field bus profile settings" was activated. The command execution sets user-defined parameters depending on the field bus profile to their default values.

The command can be started as follows:

1. Enter the value "0x0004" in the parameter "P-0-4090, Configuration for loading default values".
2. Start "S-0-0262, C07_x Load defaults procedure command".

Diagnostic Command Messages



With the parameter S-0-0262, it is possible to start other commands. In parameter "P-0-4090, Configuration for loading default values", it is possible to set which commands is started.

C0740 - Attributes Display: C07_4
 Ident N°: C0740

10.1.11 C0750 Load defaults procedure command (factory settings)

Allocation	Contained in 02VRS:	«MPB»	«MPH»	«MPD»	
	Contained in 03VRS:	«MPB»	«MPH»	«MPD»	
	Contained in 04VRS:	«MPB»	«MPH»	«MPD»	
	Contained in 05VRS:	«MPB»	«MPH»	«MPD»	
	Contained in 06VRS:	«MPB»	«MPH»	«MPD»	«MPC»
	Contained in 07VRS:	«MPB»	«MPH»	«MPD»	«MPC»
	Contained in 08VRS:	«MPB»	«MPH»	«MPD»	«MPC»
	Supported by supply unit:	«-»			



Up to MPx07, the name of this diagnostic message was "C0750 Load defaults procedure com. (load basic parameters)".

By executing command "C0750 Load defaults procedure command (factory settings)", the parameters stored in non-volatile form are reset to the factory settings. It is possible to exclude parameters of certain subfunctions from loading of default values (see "P-0-4090, Configuration for loading default values").

The command can be started as follows:

1. Enter value "0x0001" in parameter "P-0-4090, Configuration for loading default values".
2. Use bits 4 to 7 in "P-0-4090, Configuration for loading default values" to select the parameter values to be maintained.
3. Start "S-0-0262, C07_x Load defaults procedure command".

NOTICE

Damage to the internal memory (flash) caused by too many write accesses!

During the execution of this command, data are written to the internal memory (flash). This memory, however, only allows a limited number of write accesses. For this reason, you should make sure that such write accesses are not carried out too often (a maximum of approx. 100,000 writing cycles).

C0750 - Attributes Display: C07_1
 Ident N°: C0750

10.1.12 C0800 Load basic parameters command

Allocation	Contained in 02VRS:	«-»	«-»	«-»	
	Contained in 03VRS:	«-»	«-»	«-»	
	Contained in 04VRS:	«-»	«-»	«-»	
	Contained in 05VRS:	«-»	«-»	«-»	
	Contained in 06VRS:	«-»	«-»	«-»	«-»
	Contained in 07VRS:	«-»	«-»	«-»	«-»
	Contained in 08VRS:	«-»	«-»	«-»	«-»
	Supported by supply unit:	«HMV»			



This command is only available for manufacturer-side testing and developing purposes!

C0800 - Attributes Display: C0800
 Ident N°: C0800

10.1.13 C0900 Position spindle command

Allocation	Contained in 02VRS:	«MPB»	«MPH»	«-»	
	Contained in 03VRS:	«MPB»	«MPH»	«MPD»	
	Contained in 04VRS:	«MPB»	«MPH»	«MPD»	
	Contained in 05VRS:	«MPB»	«MPH»	«MPD»	
	Contained in 06VRS:	«MPB»	«MPH»	«MPD»	«MPC»
	Contained in 07VRS:	«MPB»	«MPH»	«MPD»	«MPC»
	Contained in 08VRS:	«MPB»	«MPH»	«MPD»	«MPC»
	Supported by supply unit:	«-»			

Via the control unit the "S-0-0152, C0900 Position spindle command" parameter was activated.

See also Functional Description of firmware "Spindle Positioning"

C0900 - Attributes Display: C09
 Ident N°: C0900

10.1.14 C1200 Commutation offset setting command

Allocation	Contained in 02VRS:	«MPB»	«MPH»	«MPD»	
	Contained in 03VRS:	«MPB»	«MPH»	«MPD»	
	Contained in 04VRS:	«MPB»	«MPH»	«MPD»	
	Contained in 05VRS:	«MPB»	«MPH»	«MPD»	
	Contained in 06VRS:	«MPB»	«MPH»	«MPD»	«MPC»
	Contained in 07VRS:	«MPB»	«MPH»	«MPD»	«MPC»
	Contained in 08VRS:	«MPB»	«MPH»	«MPD»	«MPC»
	Supported by supply unit:	«-»			

The command for setting the commutation offset, "P-0-0524, C1200 Commutation offset setting command", was activated.

Which one of the two methods with current (saturation or sine-wave method) is to be active has to be set in "P-0-0522, Control word for commutation setting" before.



Correctly set commutation offset is obligatory for operating synchronous kit motors and synchronous third-party motors!

See also Functional Description of firmware "Commutation Setting"

C1200 - Attributes Display: C12
 Ident N°: C1200

10.1.15 C1300 Positive stop drive procedure command

Allocation	Contained in 02VRS:	«MPB»	«MPH»	«MPD»	
	Contained in 03VRS:	«MPB»	«MPH»	«MPD»	
	Contained in 04VRS:	«MPB»	«MPH»	«MPD»	
	Contained in 05VRS:	«MPB»	«MPH»	«MPD»	
	Contained in 06VRS:	«MPB»	«MPH»	«MPD»	«MPC»
	Contained in 07VRS:	«MPB»	«MPH»	«MPD»	«MPC»
	Contained in 08VRS:	«MPB»	«MPH»	«MPD»	«MPC»
	Supported by supply unit:	«-»			

The command "S-0-0149, C1300 Positive stop drive procedure command" was activated.

See also Functional Description of firmware "Positive Stop Drive Procedure"

C1300 - Attributes Display: C13
 Ident N°: C1300

Diagnostic Command Messages

10.1.16 C1400 Command Get marker position

Allocation	Contained in 02VRS:	«MPB»	«MPH»	«MPD»	
	Contained in 03VRS:	«MPB»	«MPH»	«MPD»	
	Contained in 04VRS:	«MPB»	«MPH»	«MPD»	
	Contained in 05VRS:	«MPB»	«MPH»	«MPD»	
	Contained in 06VRS:	«MPB»	«MPH»	«MPD»	«MPC»
	Contained in 07VRS:	«MPB»	«MPH»	«MPD»	«MPC»
	Contained in 08VRS:	«MPB»	«MPH»	«MPD»	«MPC»
	Supported by supply unit:	«-»			

The "P-0-0014, C1400 Command Get marker position command" was started.

The "C14" display signals that the command is executed.

In the case of incremental measuring systems, the reference mark is checked for correct detection.

See also Functional Description of firmware "Detect marker position"

C1400 - Attributes	Display:	C14
	Ident N°:	C1400

10.1.17 C1500 Cancel reference point procedure command

Allocation	Contained in 02VRS:	«-»	«-»	«-»	
	Contained in 03VRS:	«MPB»	«MPH»	«MPD»	
	Contained in 04VRS:	«MPB»	«MPH»	«MPD»	
	Contained in 05VRS:	«MPB»	«MPH»	«MPD»	
	Contained in 06VRS:	«MPB»	«MPH»	«MPD»	«MPC»
	Contained in 07VRS:	«MPB»	«MPH»	«MPD»	«MPC»
	Contained in 08VRS:	«MPB»	«MPH»	«MPD»	«MPC»
	Supported by supply unit:	«-»			

The command "S-0-0191, C1500 Cancel reference point procedure command" was started.

The "C15" display signals that the command is executed.

The reference of the encoder selected via "S-0-0147, Homing parameter" is cleared.

See also Functional Description of firmware "Drive-Controlled Homing"

C1500 - Attributes	Display:	C15
	Ident N°:	C1500

10.1.18 C1600 Parking axis command

Allocation	Contained in 02VRS:	«-»	«-»	«-»	
	Contained in 03VRS:	«MPB»	«MPH»	«MPD»	
	Contained in 04VRS:	«MPB»	«MPH»	«MPD»	
	Contained in 05VRS:	«MPB»	«MPH»	«MPD»	
	Contained in 06VRS:	«MPB»	«MPH»	«MPD»	«MPC»
	Contained in 07VRS:	«MPB»	«MPH»	«MPD»	«MPC»
	Contained in 08VRS:	«MPB»	«MPH»	«MPD»	«MPC»
	Supported by supply unit:	«-»			

The command "S-0-0139, C1600 Parking axis command" has been activated.

See also Functional Description of firmware "Parking Axis"

C1600 - Attributes	Display:	PA
	Ident N°:	C1600

10.1.19 C1700 Command measuring wheel mode

Allocation	Contained in 02VRS:	«MPB»	«MPH»	«MPD»	
	Contained in 03VRS:	«MPB»	«MPH»	«MPD»	
	Contained in 04VRS:	«-»	«-»	«-»	
	Contained in 05VRS:	«-»	«-»	«-»	
	Contained in 06VRS:	«-»	«-»	«-»	«-»
	Contained in 07VRS:	«-»	«-»	«-»	«-»
	Contained in 08VRS:	«-»	«-»	«-»	«-»
	Supported by supply unit:	«-»			

The "P-0-0240, C1700 Command measuring wheel mode" was started.

C1700 - Attributes	Display:	C17
	Ident N°:	C1700

10.1.20 C1800 Command Drive optimization / command value box

Allocation	Contained in 02VRS:	«MPB»	«MPH»	«MPD»	
	Contained in 03VRS:	«MPB»	«MPH»	«MPD»	
	Contained in 04VRS:	«MPB»	«MPH»	«MPD»	
	Contained in 05VRS:	«MPB»	«MPH»	«MPD»	
	Contained in 06VRS:	«MPB»	«MPH»	«MPD»	«MPC»
	Contained in 07VRS:	«MPB»	«MPH»	«MPD»	«MPC»
	Contained in 08VRS:	«MPB»	«MPH»	«MPD»	«MPC»
	Supported by supply unit:	«-»			

By starting the command "P-0-0162, C1800 Command Automatic control loop adjust" automatic control loop setting is carried out in the drive, if the drive is in control at the start of the command (i.e. drive enable must have been set).

⚠ WARNING

⇒ Starting the command C1800 can immediately trigger a motion, if **drive enable and drive start** are set at the drive.

⇒ The drive **automatically** (i.e. without external command value input) carries out **motions** within the travel range defined before with the two limits ("P-0-0166, Lower limit for autom. control loop adjust" and "P-0-0167, Upper limit for autom. control loop adjust").

Check and make sure that the E-Stop circuit and the travel range limit switches are working.

See also Functional Description of firmware "Automatic Setting of Axis Control"

C1800 - Attributes	Display:	C18
	Ident N°:	C1800

10.1.21 C2000 Command Release motor holding brake

Allocation	Contained in 02VRS:	«MPB»	«MPH»	«MPD»	
	Contained in 03VRS:	«MPB»	«MPH»	«MPD»	
	Contained in 04VRS:	«MPB»	«MPH»	«MPD»	
	Contained in 05VRS:	«MPB»	«MPH»	«MPD»	
	Contained in 06VRS:	«MPB»	«MPH»	«MPD»	«MPC»
	Contained in 07VRS:	«MPB»	«MPH»	«MPD»	«MPC»
	Contained in 08VRS:	«MPB»	«MPH»	«MPD»	«MPC»
	Supported by supply unit:	«-»			

The command "P-0-0542, C2000 Command Release motor holding brake" was started.

During the command execution, the motor holding brake is released.

Diagnostic Command Messages

The "C20" display signals that the command is executed.

See also Functional Description of firmware "Motor Holding Brake"

C2000 - Attributes	Display:	C20
	Ident N°:	C2000

10.1.22 C2100 Command Holding system check

Allocation	Contained in 02VRS:	«MPB»	«MPH»	«MPD»	
	Contained in 03VRS:	«MPB»	«MPH»	«MPD»	
	Contained in 04VRS:	«MPB»	«MPH»	«MPD»	
	Contained in 05VRS:	«MPB»	«MPH»	«MPD»	
	Contained in 06VRS:	«MPB»	«MPH»	«MPD»	«MPC»
	Contained in 07VRS:	«MPB»	«MPH»	«MPD»	«MPC»
	Contained in 08VRS:	«MPB»	«MPH»	«MPD»	«MPC»
	Supported by supply unit:	«-»			

The command "P-0-0541, C2100 Holding system check command" was activated.

See also Functional Description of firmware "Holding Brake"

C2100 - Attributes	Display:	C21
	Ident N°:	C2100

10.1.23 C2200 Backup working memory procedure command

Allocation	Contained in 02VRS:	«MPB»	«MPH»	«MPD»	
	Contained in 03VRS:	«MPB»	«MPH»	«MPD»	
	Contained in 04VRS:	«MPB»	«MPH»	«MPD»	
	Contained in 05VRS:	«MPB»	«MPH»	«MPD»	
	Contained in 06VRS:	«MPB»	«MPH»	«MPD»	«MPC»
	Contained in 07VRS:	«MPB»	«MPH»	«MPD»	«MPC»
	Contained in 08VRS:	«MPB»	«MPH»	«MPD»	«MPC»
	Supported by supply unit:	«-»			

The command "S-0-0264, C2200 Backup working memory procedure command" was activated.

⚠ CAUTION

Damage to the internal memory (flash) caused by too many write accesses!

⇒ During the execution of this command, data are written to the internal memory (flash). As each flash only allows a limited number of write accesses before its memory locations are destroyed, you should make sure that such write accesses won't be carried out too often.

C2200 - Attributes	Display:	C22
	Ident N°:	C2200

10.1.24 C2300 Load working memory procedure command

Allocation	Contained in 02VRS:	«MPB»	«MPH»	«MPD»	
	Contained in 03VRS:	«MPB»	«MPH»	«MPD»	
	Contained in 04VRS:	«MPB»	«MPH»	«MPD»	
	Contained in 05VRS:	«MPB»	«MPH»	«MPD»	
	Contained in 06VRS:	«MPB»	«MPH»	«MPD»	«MPC»
	Contained in 07VRS:	«MPB»	«MPH»	«MPD»	«MPC»
	Contained in 08VRS:	«MPB»	«MPH»	«MPD»	«MPC»
	Supported by supply unit:	«-»			

The command "S-0-0263, C2300 Load working memory procedure command" was activated.

⚠ CAUTION Damage to the internal memory (flash) caused by too many write accesses!

⇒ During the execution of this command, data are written to the internal memory (flash). As each flash only allows a limited number of write accesses before its memory locations are destroyed, you should make sure that such write accesses won't be carried out too often.

C2300 - Attributes Display: C23
 Ident N°: C2300

10.1.25 C2400 Selectively backup working memory procedure command

Allocation	Contained in 02VRS:	«MPB»	«MPH»	«MPD»	
	Contained in 03VRS:	«MPB»	«MPH»	«MPD»	
	Contained in 04VRS:	«MPB»	«MPH»	«MPD»	
	Contained in 05VRS:	«MPB»	«MPH»	«MPD»	
	Contained in 06VRS:	«MPB»	«MPH»	«MPD»	«MPC»
	Contained in 07VRS:	«MPB»	«MPH»	«MPD»	«MPC»
	Contained in 08VRS:	«MPB»	«MPH»	«MPD»	«MPC»
	Supported by supply unit:	«-»			

The "S-0-0293, C2400 Selectively backup working memory procedure command" was activated.

C2400 - Attributes Display: C24
 Ident N°: C2400

10.1.26 C2500 Copy IDN from optional memory to internal memory

Allocation	Contained in 02VRS:	«MPB»	«MPH»	«MPD»	
	Contained in 03VRS:	«MPB»	«MPH»	«MPD»	
	Contained in 04VRS:	«MPB»	«MPH»	«MPD»	
	Contained in 05VRS:	«MPB»	«MPH»	«MPD»	
	Contained in 06VRS:	«MPB»	«MPH»	«MPD»	«MPC»
	Contained in 07VRS:	«MPB»	«MPH»	«MPD»	«MPC»
	Contained in 08VRS:	«MPB»	«MPH»	«MPD»	«MPC»
	Supported by supply unit:	«-»			

The command "P-0-4091, C2500 Copy IDN from optional memory to internal memory" was started.

All parameters are copied from the optional memory (MMC) to the internal memory (flash).

The display "C25" signals that the command is executed and the parameters are loaded from the MMC to the drive.

 The MMC can only be used as an optional memory for control sections with MMC slot.

⚠ CAUTION Damage to the internal memory (flash) caused by too many write accesses!

⇒ During the execution of this command, data are written to the internal memory (flash). As each flash only allows a limited number of write accesses before its memory locations are destroyed, you should make sure that such write accesses won't be carried out too often.

See also Functional Description of firmware "Loading, Storing and Saving Parameters"

Diagnostic Command Messages

C2500 - Attributes Display: C25
 Ident N°: C2500

10.1.27 C2600 Copy IDN from internal memory to optional memory

Allocation	Contained in 02VRS:	«MPB»	«MPH»	«MPD»	
	Contained in 03VRS:	«MPB»	«MPH»	«MPD»	
	Contained in 04VRS:	«MPB»	«MPH»	«MPD»	
	Contained in 05VRS:	«MPB»	«MPH»	«MPD»	
	Contained in 06VRS:	«MPB»	«MPH»	«MPD»	«MPC»
	Contained in 07VRS:	«MPB»	«MPH»	«MPD»	«MPC»
	Contained in 08VRS:	«MPB»	«MPH»	«MPD»	«MPC»
	Supported by supply unit:	«-»			

The command "P-0-4092, C2600 Copy IDN from internal memory to optional memory" was **started**.

All parameters are copied from the internal memory (flash) to the optional memory (MMC).

The display "C26" signals that the command is executed and the parameters are written from the drive to the MMC.



The MMC can only be used as an optional memory for control sections with MMC slot.

CAUTION

Damage to the internal memory (flash) caused by too many write accesses!

⇒ During the execution of this command, data are written to the internal memory (flash). As each flash only allows a limited number of write accesses before its memory locations are destroyed, you should make sure that such write accesses won't be carried out too often.

See also Functional Description of firmware "Loading, Storing and Saving Parameters"

C2600 - Attributes Display: C26
 Ident N°: C2600

10.1.28 C2800 Analog input adjustment command

Allocation	Contained in 02VRS:	«MPB»	«MPH»	«MPD»	
	Contained in 03VRS:	«MPB»	«MPH»	«MPD»	
	Contained in 04VRS:	«MPB»	«MPH»	«MPD»	
	Contained in 05VRS:	«MPB»	«MPH»	«MPD»	
	Contained in 06VRS:	«MPB»	«MPH»	«MPD»	«MPC»
	Contained in 07VRS:	«MPB»	«MPH»	«MPD»	«MPC»
	Contained in 08VRS:	«MPB»	«MPH»	«MPD»	«MPC»
	Supported by supply unit:	«-»			

By executing the command "P-0-0220, C2800 Analog input adjustment command", it is possible to carry out an automatic adjustment (zero point and gain) of the analog input.



The command is controlled by the settings in "P-0-0218, Analog input, control parameter".

The execution of the command takes some time; the status of the command can be polled via the assigned command parameter.

See also Functional Description of firmware:

- "Command Processing"

Diagnostic Command Messages

10.1.31 C3100 Recalculate actual value cycle

Allocation	Contained in 02VRS:	«MPB»	«MPH»	«MPD»	
	Contained in 03VRS:	«MPB»	«MPH»	«MPD»	
	Contained in 04VRS:	«MPB»	«MPH»	«MPD»	
	Contained in 05VRS:	«MPB»	«MPH»	«MPD»	
	Contained in 06VRS:	«MPB»	«MPH»	«MPD»	«MPC»
	Contained in 07VRS:	«MPB»	«MPH»	«MPD»	«MPC»
	Contained in 08VRS:	«MPB»	«MPH»	«MPD»	«MPC»
	Supported by supply unit:	«-»			

When the command "P-0-0071, C3100 C3100 Command Recalculate actual value cycle" is executed, the modulo value for the actual value cycle is recalculated.

The calculated modulo value can be taken from the parameter "P-0-0786, Modulo value actual value cycle".

C3100 - Attributes	Display:	C31
	Ident N°:	C3100

10.1.32 C3200 Command Calculate motor data

Allocation	Contained in 02VRS:	«MPB»	«MPH»	«MPD»	
	Contained in 03VRS:	«MPB»	«MPH»	«MPD»	
	Contained in 04VRS:	«MPB»	«MPH»	«MPD»	
	Contained in 05VRS:	«MPB»	«MPH»	«MPD»	
	Contained in 06VRS:	«MPB»	«MPH»	«MPD»	«MPC»
	Contained in 07VRS:	«MPB»	«MPH»	«MPD»	«MPC»
	Contained in 08VRS:	«MPB»	«MPH»	«MPD»	«MPC»
	Supported by supply unit:	«-»			

The command is started via the command parameter "P-0-4033, C3200 Command Calculate motor data".

While the command is executed, the values in "P-0-4032, Motor type plate data" are checked for validity and completeness. Then the motor parameters are calculated according to type plate data.



To calculate the controller parameters the current settings is "P-0-0001, Switching frequency of the power output stage" and "P-0-0556, Control word of axis controller" (with regard to controller performance) are taken as basis. If one of these parameters is changed after the command has been started, the controller settings may not be correct any more.

C3200 - Attributes	Display:	C32
	Ident N°:	C3200

10.1.33 C3300 Set coordinate system procedure command

Allocation	Contained in 02VRS:	«MPB»	«MPH»	«MPD»	
	Contained in 03VRS:	«MPB»	«MPH»	«MPD»	
	Contained in 04VRS:	«MPB»	«MPH»	«MPD»	
	Contained in 05VRS:	«MPB»	«MPH»	«MPD»	
	Contained in 06VRS:	«MPB»	«MPH»	«MPD»	«MPC»
	Contained in 07VRS:	«MPB»	«MPH»	«MPD»	«MPC»
	Contained in 08VRS:	«MPB»	«MPH»	«MPD»	«MPC»
	Supported by supply unit:	«-»			

The command for setting the coordinate system ("S-0-0197, C3300 Set coordinate system procedure command") was activated.

See also Functional Description of firmware "Shifting the Position Data Reference for Relative and Absolute Measuring Systems"

C3300 - Attributes Display: C33
 Ident N°: C3300

10.1.34 C3400 Shift coordinate system procedure command

Allocation	Contained in 02VRS:	«MPB»	«MPH»	«MPD»	
	Contained in 03VRS:	«MPB»	«MPH»	«MPD»	
	Contained in 04VRS:	«MPB»	«MPH»	«MPD»	
	Contained in 05VRS:	«MPB»	«MPH»	«MPD»	
	Contained in 06VRS:	«MPB»	«MPH»	«MPD»	«MPC»
	Contained in 07VRS:	«MPB»	«MPH»	«MPD»	«MPC»
	Contained in 08VRS:	«MPB»	«MPH»	«MPD»	«MPC»
	Supported by supply unit:	«-»			

The command for shifting the coordinate system ("S-0-0199, C3400 Shift coordinate system procedure command") was activated.

See also Functional Description of firmware "Shifting the Position Data Reference for Relative and Absolute Measuring Systems"

C3400 - Attributes Display: C34
 Ident N°: C3400

10.1.35 C3500 Command Determine encoder correction values

Allocation	Contained in 02VRS:	«MPB»	«MPH»	«MPD»	
	Contained in 03VRS:	«MPB»	«MPH»	«MPD»	
	Contained in 04VRS:	«MPB»	«MPH»	«MPD»	
	Contained in 05VRS:	«MPB»	«MPH»	«MPD»	
	Contained in 06VRS:	«-»	«-»	«-»	«-»
	Contained in 07VRS:	«-»	«-»	«-»	«-»
	Contained in 08VRS:	«-»	«-»	«-»	«-»
	Supported by supply unit:	«-»			

By executing the command "P-0-0340, C3500 Command Determine encoder correction values" signal shape errors of a measuring system with sinusoidal signals are determined and correction values are stored in "P-0-0342, Correction value table for encoder correction".

The encoder the signal shape error of which is to be compensated has to be selected in "P-0-0341, Control word for encoder correction".

C3500 - Attributes Display: C35
 Ident N°: C3500

10.1.36 C3600 Command Motor data identification

Allocation	Contained in 02VRS:	«-»	«-»	«-»	
	Contained in 03VRS:	«MPB»	«MPH»	«MPD»	
	Contained in 04VRS:	«MPB»	«MPH»	«MPD»	
	Contained in 05VRS:	«MPB»	«MPH»	«MPD»	
	Contained in 06VRS:	«MPB»	«MPH»	«MPD»	«MPC»
	Contained in 07VRS:	«MPB»	«MPH»	«MPD»	«MPC»
	Contained in 08VRS:	«MPB»	«MPH»	«MPD»	«MPC»
	Supported by supply unit:	«-»			

The command "P-0-0565, C3600 Command Motor data identification" has been activated.

See also Functional Description of firmware "Automatic Setting of Motor Control"

C3600 - Attributes Display: C36
 Ident N°: C3600

Diagnostic Command Messages

10.1.37 C3700 Manually unlocking the safety door

Allocation	Contained in 02VRS:	«MPB»	«MPH»	«MPD»	
	Contained in 03VRS:	«MPB»	«MPH»	«MPD»	
	Contained in 04VRS:	«MPB»	«MPH»	«MPD»	
	Contained in 05VRS:	«MPB»	«MPH»	«MPD»	
	Contained in 06VRS:	«MPB»	«MPH»	«MPD»	«MPC»
	Contained in 07VRS:	«MPB»	«MPH»	«MPD»	«MPC»
	Contained in 08VRS:	«MPB»	«MPH»	«MPD»	«MPC»
	Supported by supply unit:	«-»			

In the case of an encoder error the safety technology can no longer guarantee dual-channel safety. It would then be impossible, for example, to detect a coasting spindle.



Executing command C3700 is only allowed when there is a safety technology error in the drive.

⚠ DANGER

Lethal injury caused by moving parts in the safety zone!

⇒ The locking device of the safety door may only be unlocked by command C3700 after an additional visual check.

Behavior After the execution of command C3700 ("P-0-3218, C3700 Manually unlocking the safety door"), the drive signals safety via EA20 in spite of the encoder error. In the special mode "safety related stopping process" (selected via operating mode switch), the safety technology master can unlock the locking device of the safety door although an axis in the safety zone has an encoder error.

C3700 - Attributes

Display:	C37
Ident N°:	C3700

10.1.38 C3800 Command Apply motor holding brake

Allocation	Contained in 02VRS:	«MPB»	«MPH»	«MPD»	
	Contained in 03VRS:	«MPB»	«MPH»	«MPD»	
	Contained in 04VRS:	«MPB»	«MPH»	«MPD»	
	Contained in 05VRS:	«MPB»	«MPH»	«MPD»	
	Contained in 06VRS:	«MPB»	«MPH»	«MPD»	«MPC»
	Contained in 07VRS:	«MPB»	«MPH»	«MPD»	«MPC»
	Contained in 08VRS:	«MPB»	«MPH»	«MPD»	«MPC»
	Supported by supply unit:	«-»			

The command "P-0-0543, C3800 Command Apply motor holding brake" was started.

While the command is executed the motor holding brake is applied.

See also Functional Description of firmware "Motor Holding Brake"

C3800 - Attributes

Display:	C38
Ident N°:	C3800

10.1.39 C3900 Command Holding brake resurfacing

Allocation	Contained in 02VRS:	«MPB»	«MPH»	«MPD»	
	Contained in 03VRS:	«MPB»	«MPH»	«MPD»	
	Contained in 04VRS:	«MPB»	«MPH»	«MPD»	
	Contained in 05VRS:	«MPB»	«MPH»	«MPD»	
	Contained in 06VRS:	«MPB»	«MPH»	«MPD»	«MPC»
	Contained in 07VRS:	«MPB»	«MPH»	«MPD»	«MPC»
	Contained in 08VRS:	«MPB»	«MPH»	«MPD»	«MPC»
	Supported by supply unit:	«-»			

The command "P-0-0544, C3900 Command Abrasion of holding brake" was activated.

See also Functional Description of firmware "Holding Brake"

C3900 - Attributes	Display:	C39
	Ident N°:	C3900

10.1.40 C4000 Homing procedure command channel 2

Allocation	Contained in 02VRS:	«MPB»	«MPH»	«MPD»	
	Contained in 03VRS:	«MPB»	«MPH»	«MPD»	
	Contained in 04VRS:	«MPB»	«MPH»	«MPD»	
	Contained in 05VRS:	«MPB»	«MPH»	«MPD»	
	Contained in 06VRS:	«MPB»	«MPH»	«MPD»	«MPC»
	Contained in 07VRS:	«MPB»	«MPH»	«MPD»	«MPC»
	Contained in 08VRS:	«MPB»	«MPH»	«MPD»	«MPC»
	Supported by supply unit:	«-»			

The command "P-0-3228, C4000 Homing procedure command Channel 2" was started.

See also documentation "Integrated Safety Technology", keyword "Safety Related Homing Procedure"

C4000 - Attributes	Display:	C40
	Ident N°:	C4000

10.1.41 C4100 Switch parameter set command

Allocation	Contained in 02VRS:	«-»	«-»	«-»	
	Contained in 03VRS:	«MPB»	«MPH»	«-»	
	Contained in 04VRS:	«MPB»	«MPH»	«-»	
	Contained in 05VRS:	«MPB»	«MPH»	«-»	
	Contained in 06VRS:	«MPB»	«MPH»	«-»	«MPC»
	Contained in 07VRS:	«MPB»	«MPH»	«-»	«MPC»
	Contained in 08VRS:	«MPB»	«MPH»	«-»	«MPC»
	Supported by supply unit:	«-»			

The command "S-0-0216, C4100 Switch parameter set command" was started.

See also Functional Description of firmware "Parameter Set Switching"

C4100 - Attributes	Display:	C41
	Ident N°:	C4100

10.1.42 C4200 Drive-controlled oscillation command

Allocation	Contained in 02VRS:	«-»	«-»	«-»	
	Contained in 03VRS:	«MPB»	«MPH»	«-»	
	Contained in 04VRS:	«MPB»	«MPH»	«-»	
	Contained in 05VRS:	«MPB»	«MPH»	«-»	
	Contained in 06VRS:	«MPB»	«MPH»	«-»	«MPC»
	Contained in 07VRS:	«MPB»	«MPH»	«-»	«MPC»
	Contained in 08VRS:	«MPB»	«MPH»	«-»	«MPC»
	Supported by supply unit:	«-»			

Diagnostic Command Messages

The command "S-0-0190, C4200 Drive-controlled oscillation command" was started.

See also Functional Description of firmware "Drive-Controlled Oscillation"

C4200 - Attributes Display: C42
 Ident N°: C4200

10.1.43 C4300 NC-controlled homing procedure command

Allocation	Contained in 02VRS:	«-»	«-»	«-»	
	Contained in 03VRS:	«MPB»	«MPH»	«MPD»	
	Contained in 04VRS:	«MPB»	«MPH»	«MPD»	
	Contained in 05VRS:	«MPB»	«MPH»	«MPD»	
	Contained in 06VRS:	«MPB»	«MPH»	«MPD»	«MPC»
	Contained in 07VRS:	«MPB»	«MPH»	«MPD»	«MPC»
	Contained in 08VRS:	«MPB»	«MPH»	«MPD»	«MPC»
	Supported by supply unit:	«-»			

The command for NC-controlled homing ("S-0-0146, C4300 NC-controlled homing procedure command") was activated. The master inputs the command values for moving the axis to the reference point and controls the homing procedure via commands and the respective parameters.



The control information for homing has to be defined in "S-0-0147, Homing parameter".

See also Functional Description of firmware "Establishing Position Data Reference for Relative Measuring Systems"

C4300 - Attributes Display: C43
 Ident N°: C4300

10.1.44 C4400 Calculate displacement procedure command

Allocation	Contained in 02VRS:	«-»	«-»	«-»	
	Contained in 03VRS:	«MPB»	«MPH»	«MPD»	
	Contained in 04VRS:	«MPB»	«MPH»	«MPD»	
	Contained in 05VRS:	«MPB»	«MPH»	«MPD»	
	Contained in 06VRS:	«MPB»	«MPH»	«MPD»	«MPC»
	Contained in 07VRS:	«MPB»	«MPH»	«MPD»	«MPC»
	Contained in 08VRS:	«MPB»	«MPH»	«MPD»	«MPC»
	Supported by supply unit:	«-»			

The command for calculating the displacement values ("S-0-0171, Calculate displacement procedure command") was activated.

See also "S-0-0175, Offset parameter 1" and "S-0-0176, Offset parameter 2"

See also Functional Description of firmware "Establishing Position Data Reference for Relative Measuring Systems"

C4400 - Attributes Display: C44
 Ident N°: C4400

10.1.45 C4500 Displacement to referenced system procedure command

Allocation	Contained in 02VRS:	«-»	«-»	«-»	
	Contained in 03VRS:	«MPB»	«MPH»	«MPD»	
	Contained in 04VRS:	«MPB»	«MPH»	«MPD»	
	Contained in 05VRS:	«MPB»	«MPH»	«MPD»	
	Contained in 06VRS:	«MPB»	«MPH»	«MPD»	«MPC»
	Contained in 07VRS:	«MPB»	«MPH»	«MPD»	«MPC»
	Contained in 08VRS:	«MPB»	«MPH»	«MPD»	«MPC»
	Supported by supply unit:	«-»			

Diagnostic Command Messages

The command "S-0-0172, C4500 Displacement to referenced system procedure command" was activated.

See also Functional Description of firmware "Establishing Position Data Reference for Relative Measuring Systems"

C4500 - Attributes Display: C45
 Ident N°: C4500

10.1.46 C4600 Command Calculate motor control parameters

Allocation	Contained in 02VRS:	«-»	«-»	«-»	
	Contained in 03VRS:	«MPB»	«MPH»	«MPD»	
	Contained in 04VRS:	«MPB»	«MPH»	«MPD»	
	Contained in 05VRS:	«MPB»	«MPH»	«MPD»	
	Contained in 06VRS:	«MPB»	«MPH»	«MPD»	«MPC»
	Contained in 07VRS:	«MPB»	«MPH»	«MPD»	«MPC»
	Contained in 08VRS:	«MPB»	«MPH»	«MPD»	«MPC»
	Supported by supply unit:	«-»			

The command "P-0-0566, C4600 Command Calculate motor control parameters" has been activated.

See also Functional Description of firmware "Automatic Setting of Motor Control"

C4600 - Attributes Display: C46
 Ident N°: C4600

10.1.47 C4700 Command Activate easy startup mode

Allocation	Contained in 02VRS:	«-»	«-»	«-»	
	Contained in 03VRS:	«MPB»	«MPH»	«MPD»	
	Contained in 04VRS:	«MPB»	«MPH»	«MPD»	
	Contained in 05VRS:	«-»	«-»	«-»	
	Contained in 06VRS:	«-»	«-»	«-»	«-»
	Contained in 07VRS:	«-»	«-»	«-»	«-»
	Contained in 08VRS:	«-»	«-»	«-»	«-»
	Supported by supply unit:	«-»			

The command for starting the "easy startup" mode (commissioning mode for SERCOS and field bus devices; "P-0-4085, C4700 Command Activate easy startup mode") was activated.

See also Functional Description of firmware "Initial Start in Easy Startup Mode"

C4700 - Attributes Display: C47
 Ident N°: C4700

10.1.48 C4800 Command Determine cogging torque compensation table

Allocation	Contained in 02VRS:	«-»	«-»	«-»	
	Contained in 03VRS:	«-»	«-»	«-»	
	Contained in 04VRS:	«-»	«MPH»	«MPD»	
	Contained in 05VRS:	«-»	«MPH»	«MPD»	
	Contained in 06VRS:	«-»	«MPH»	«MPD»	«MPC»
	Contained in 07VRS:	«-»	«MPH»	«MPD»	«MPC»
	Contained in 08VRS:	«-»	«MPH»	«MPD»	«MPC»
	Supported by supply unit:	«-»			

The command for determining the cogging torque compensation table, "P-0-1138, C4800 Command Determine cogging torque compensation table", was started.

See also Functional Description of firmware "Cogging Torque Compensation"

Diagnostic Command Messages

C4800 - Attributes Display: C48
 Ident N°: C4800

10.1.49 C4900 PLC command

Allocation	Contained in 02VRS:	«-»	«-»	«-»	
	Contained in 03VRS:	«-»	«-»	«-»	
	Contained in 04VRS:	«MPB»	«MPH»	«-»	
	Contained in 05VRS:	«MPB»	«MPH»	«-»	
	Contained in 06VRS:	«MPB»	«MPH»	«-»	«MPC»
	Contained in 07VRS:	«MPB»	«MPH»	«-»	«MPC»
	Contained in 08VRS:	«MPB»	«MPH»	«-»	«MPC»
	Supported by supply unit:	«-»			

The command "P-0-1449, C4900 PLC command" for controlling a PLC program was started.

See also Application Manual "Rexroth IndraMotion MLD"

C4900 - Attributes Display: C49
 Ident N°: C4900

10.1.50 C5200 Communication phase 4 transition check

Allocation	Contained in 02VRS:	«-»	«-»	«-»	
	Contained in 03VRS:	«-»	«-»	«-»	
	Contained in 04VRS:	«MPB»	«MPH»	«MPD»	
	Contained in 05VRS:	«MPB»	«MPH»	«MPD»	
	Contained in 06VRS:	«MPB»	«MPH»	«MPD»	«MPC»
	Contained in 07VRS:	«MPB»	«MPH»	«MPD»	«MPC»
	Contained in 08VRS:	«MPB»	«MPH»	«MPD»	«MPC»
	Supported by supply unit:	«-»			

The command "S-0-0128, C5200 Communication phase 4 transition check" has been activated.



This status is displayed on the control panel of the drive with "C52".

C5200 - Attributes Display: C52
 Ident N°: C5200

10.1.51 C5300 SERCOS III: Command SYNC delay measurement

Allocation	Contained in 02VRS:	«-»	«-»	«-»	
	Contained in 03VRS:	«-»	«-»	«-»	
	Contained in 04VRS:	«-»	«-»	«-»	
	Contained in 05VRS:	«-»	«-»	«-»	
	Contained in 06VRS:	«MPB»	«MPH»	«MPD»	«MPC»
	Contained in 07VRS:	«MPB»	«MPH»	«MPD»	«MPC»
	Contained in 08VRS:	«MPB»	«MPH»	«MPD»	«MPC»
	Supported by supply unit:	«-»			

The command "S-0-1024, C5300 SERCOS III: SYNC delay measuring procedure command" was activated.

C5300 - Attributes Display: C53
 Ident N°: C5300

10.1.52 C5400 Command Save PLC retain data on MMC

Allocation	Contained in 02VRS:	«-»	«-»	«-»	
	Contained in 03VRS:	«-»	«-»	«-»	
	Contained in 04VRS:	«MPB»	«MPH»	«-»	
	Contained in 05VRS:	«MPB»	«MPH»	«-»	
	Contained in 06VRS:	«MPB»	«MPH»	«-»	«MPC»
	Contained in 07VRS:	«MPB»	«MPH»	«-»	«MPC»
	Contained in 08VRS:	«MPB»	«MPH»	«-»	«MPC»
	Supported by supply unit:	«-»			



To execute the command "P-0-4054, C5400 Command Save PLC retain data on MMC",

- a PLC program must have been loaded and
- a control section with MMC slot and plugged MMC (MultiMediaCard) must be used.

It is recommended that you bring the PLC to status "STOP" before starting the command, in order not to violate the data consistency.

When the command is executed, the PLC retain data ("P-0-1359, SPS Retain data") are copied from the internal memory to the optional memory [MultiMediaCard (MMC)]. The data are stored in the folder "PLC" in the file "SPS-Retain.pbf".

See also MLD Application Manual "Working With Retain Variables" and "File System in the Drive"

C5400 - Attributes	Display:	C54
	Ident N°:	C5400

10.1.53 C5500 Command Load PLC retain data from MMC

Allocation	Contained in 02VRS:	«-»	«-»	«-»	
	Contained in 03VRS:	«-»	«-»	«-»	
	Contained in 04VRS:	«MPB»	«MPH»	«-»	
	Contained in 05VRS:	«MPB»	«MPH»	«-»	
	Contained in 06VRS:	«MPB»	«MPH»	«-»	«MPC»
	Contained in 07VRS:	«MPB»	«MPH»	«-»	«MPC»
	Contained in 08VRS:	«MPB»	«MPH»	«-»	«MPC»
	Supported by supply unit:	«-»			



To execute command "P-0-4055, C5500 Command Load PLC retain data from MMC", the following requirements must be met:

- A control section with MMC slot and plugged MMC (MultiMediaCard) must be used.
- The axis must be in status "PM".
- The PLC must be in status "STOP".
- The PLC program which is appropriate for the retain data must have been loaded as boot project.

The command causes the following actions:

1. It stops the PLC program (only if C55 was loaded via the control panel).
2. It initiates a PLC cold start.
3. It loads the PLC boot project.
4. It loads the PLC retain data ("P-0-1359, PLC retain data") from the optional memory [MultiMediaCard (MMC)] to the internal memory.

Diagnostic Command Messages

5. The PLC program starts automatically on next switchover to OM (only if C55 was started via the control panel).

See also MLD Application Manual "Working With Retain Variables" and "File System in the Drive"

C5500 - Attributes Display: C55
 Ident N°: C5500

10.1.54 C5600 Command subsequent optimization of commutation offset

Allocation	Contained in 02VRS:	«-»	«-»	«-»	
	Contained in 03VRS:	«-»	«-»	«-»	
	Contained in 04VRS:	«MPB»	«MPH»	«MPD»	
	Contained in 05VRS:	«MPB»	«MPH»	«MPD»	
	Contained in 06VRS:	«MPB»	«MPH»	«MPD»	«MPC»
	Contained in 07VRS:	«MPB»	«MPH»	«MPD»	«MPC»
	Contained in 08VRS:	«MPB»	«MPH»	«MPD»	«MPC»
	Supported by supply unit:	«-»			

The command for subsequent optimization of the commutation offset setting, "P-0-0518, C5600 Command subsequent optimization of commutation offset", was activated.

The "C56" display signals that the command is executed.

See also Functional Description of firmware "Commutation Setting"

C5600 - Attributes Display: C56
 Ident N°: C5600

10.1.55 C5800 Command Apply redundant holding brake

Allocation	Contained in 02VRS:	«-»	«-»	«-»	
	Contained in 03VRS:	«-»	«-»	«-»	
	Contained in 04VRS:	«MPB»	«MPH»	«MPD»	
	Contained in 05VRS:	«MPB»	«MPH»	«MPD»	
	Contained in 06VRS:	«MPB»	«MPH»	«MPD»	«MPC»
	Contained in 07VRS:	«MPB»	«MPH»	«MPD»	«MPC»
	Contained in 08VRS:	«MPB»	«MPH»	«MPD»	«MPC»
	Supported by supply unit:	«-»			

The command "P-0-3313, C5800 Command Apply redundant holding brake" was started.

While the command is executed the redundant motor holding brake is applied.

See also Functional Description of firmware "Motor Holding Brake"

C5800 - Attributes Display: C58
 Ident N°: C5800

10.1.56 C5900 Command Resurfacing of redundant holding brake

Allocation	Contained in 02VRS:	«-»	«-»	«-»	
	Contained in 03VRS:	«-»	«-»	«-»	
	Contained in 04VRS:	«MPB»	«MPH»	«MPD»	
	Contained in 05VRS:	«MPB»	«MPH»	«MPD»	
	Contained in 06VRS:	«MPB»	«MPH»	«MPD»	«MPC»
	Contained in 07VRS:	«MPB»	«MPH»	«MPD»	«MPC»
	Contained in 08VRS:	«MPB»	«MPH»	«MPD»	«MPC»
	Supported by supply unit:	«-»			

The command "P-0-3314, C5900 Command Resurfacing of redundant holding brake" was activated.

See also Functional Description of firmware "Motor Holding Brake"

C5900 - Attributes Display: C59
 Ident N°: C5900

10.1.57 C6000 Set absolute position procedure command

Allocation	Contained in 02VRS:	«-»	«-»	«-»	
	Contained in 03VRS:	«-»	«-»	«-»	
	Contained in 04VRS:	«MPB»	«MPH»	«MPD»	
	Contained in 05VRS:	«MPB»	«MPH»	«MPD»	
	Contained in 06VRS:	«MPB»	«MPH»	«MPD»	«MPC»
	Contained in 07VRS:	«MPB»	«MPH»	«MPD»	«MPC»
	Contained in 08VRS:	«MPB»	«MPH»	«MPD»	«MPC»
	Supported by supply unit:	«-»			

The command for setting the absolute measuring ("S-0-0447, C6000 Command Set absolute measuring") was activated.

See also Functional Description of firmware "Set Absolute Measuring"

C6000 - Attributes Display: C60
 Ident N°: C6000

10.1.58 C6100 Command Activate IP settings

Allocation	Contained in 02VRS:	«-»	«-»	«-»	
	Contained in 03VRS:	«-»	«-»	«-»	
	Contained in 04VRS:	«-»	«-»	«-»	
	Contained in 05VRS:	«MPB»	«MPH»	«MPD»	
	Contained in 06VRS:	«MPB»	«MPH»	«MPD»	«MPC»
	Contained in 07VRS:	«MPB»	«MPH»	«MPD»	«MPC»
	Contained in 08VRS:	«MPB»	«MPH»	«MPD»	«MPC»
	Supported by supply unit:	«-»			

The command "P-0-1534, C6100 Command Activate IP settings" was started.

The settings of all existing parameters for IP communication are first checked in the drive for verisimilar and changed values.

Interface	IP address	Network mask	Gateway address
SERCOS III master (CCD)	P-0-1641	P-0-1642	P-0-1643
Engineering over IP (master communication)	S-0-1020	S-0-1021	S-0-1022
Engineering	P-0-1531	P-0-1532	P-0-1533
Master communication	P-0-4089.0.13	P-0-4089.0.14	P-0-4089.0.15

Fig. 10-1: Parameters for IP Communication

If changes were made, the IP communication is aborted via the corresponding interface. The new settings are activated and communication with the new settings is started.



The IP communication via the interfaces for which the settings were not changed is not affected by the command and can continue without restrictions.



Before the command is executed, IP communication with the interfaces should be terminated by the IP client. Otherwise, error messages can occur in the corresponding clients due to missing communication.

Diagnostic Command Messages

C6100 - Attributes Display: C61
 Ident N°: C6100

10.1.59 C6200 Command Enabling SM without valid brake status

Allocation	Contained in 02VRS:	«-»	«-»	«-»	
	Contained in 03VRS:	«-»	«-»	«-»	
	Contained in 04VRS:	«-»	«-»	«-»	
	Contained in 05VRS:	«MPB»	«MPH»	«MPD»	
	Contained in 06VRS:	«MPB»	«MPH»	«MPD»	«MPC»
	Contained in 07VRS:	«MPB»	«MPH»	«MPD»	«MPC»
	Contained in 08VRS:	«MPB»	«MPH»	«MPD»	«MPC»
	Supported by supply unit:	«-»			



Up to MPx06, the name of this diagnostic message was "C6200 Command Enabling special mode without valid brake status".

⚠ WARNING

Dangerous movements! Danger to life, risk of injury, serious injury or property damage, as the holding torques of motor brake and/or redundant holding brake are not sufficient!

The command "C6200 Command Enabling SM without valid brake status" may only be used, when the use of the command was taken into account in the risk analysis of the installation ("danger to persons in the safety area due to brake defect").

If the point of time of the last brake check "C2100 Command Holding system check" has passed for a long operating time or downtime, the holding torques of motor brake and/or redundant holding brake might no longer be sufficient! Only the brake check can give information about the holding torques.

Moving the axis in special mode without the brakes having been checked causes additional dangers for the operator! This requires the following measures:

- The machine manual must contain explicit information on the additional danger caused when the axis is moved in special mode without the brakes having been checked.
- The operator must be informed (e.g., within the scope of a training course) on the additional danger caused when the axis is moved in special mode without the brakes having been checked.
- It may only be possible to start the command C62 at the machine in the specific safety technology context (key switch, warning on the display, ...).

The display C62 shows that the command "P-0-3315, C6200 Comm. Enabling SM without valid brake status" is active.

See also documentation "Integrated Safety Technology", chapter "Enabling the Special Mode Without Valid Brake Status"

C6200 - Attributes Display: C62
 Ident N°: C6200

10.1.60 C6400 Reboot command

Allocation	Contained in 02VRS:	«-»	«-»	«-»	
	Contained in 03VRS:	«-»	«-»	«-»	
	Contained in 04VRS:	«-»	«-»	«-»	
	Contained in 05VRS:	«-»	«-»	«-»	
	Contained in 06VRS:	«-»	«-»	«-»	
	Contained in 07VRS:	«-»	«-»	«-»	
	Contained in 08VRS:	«MPB»	«MPH»	«MPD»	«MPC»
	Supported by supply unit:	«-»			

The command for rebooting the drive (S-0-1350, Reboot command) was activated.

"C64" flashing on the display of the control panel signals that command S-0-1350 was started.



The command cannot be interrupted. While the command is executed, the parameters to be saved are stored and the drive is restarted with a delay of two seconds.

C6400 - Attributes	Display:	C64
	Ident N°:	C6400

10.1.61 C6500 Save operating data on backup memory

Allocation	Contained in 02VRS:	«-»	«-»	«-»	
	Contained in 03VRS:	«-»	«-»	«-»	
	Contained in 04VRS:	«-»	«-»	«-»	
	Contained in 05VRS:	«-»	«-»	«-»	
	Contained in 06VRS:	«-»	«-»	«-»	«MPC»
	Contained in 07VRS:	«-»	«-»	«-»	«MPC»
	Contained in 08VRS:	«-»	«-»	«-»	«MPC»
	Supported by supply unit:	«-»			

"C65" flashing on the display of the control panel signals that the command P-0-0665 was started.

During the command execution, the **parameters to be saved** are copied from the active, non-volatile memory (flash) to the MultiMediaCard (MMC).



When CCD slaves exist, the execution of the command can take several minutes. During this time, write access to the parameters to be saved should be avoided. Therefore, running PLC programs are automatically stopped during the runtime of the command.

See also Functional Description of firmware "MultiMediaCard (MMC)"

C6500 - Attributes	Display:	C65
	Ident N°:	C6500

10.1.62 C6600 Restore operating data from backup memory

Allocation	Contained in 02VRS:	«-»	«-»	«-»	
	Contained in 03VRS:	«-»	«-»	«-»	
	Contained in 04VRS:	«-»	«-»	«-»	
	Contained in 05VRS:	«-»	«-»	«-»	
	Contained in 06VRS:	«-»	«-»	«-»	«MPC»
	Contained in 07VRS:	«-»	«-»	«-»	«MPC»
	Contained in 08VRS:	«-»	«-»	«-»	«MPC»
	Supported by supply unit:	«-»			

"C66" flashing on the display of the control panel signals that the command P-0-0666 was started.

Diagnostic Command Messages

With the command C6600, the device data saved on the MultiMediaCard (MMC) are restored.

The data must have been generated before by means of the command C6500. The device data saved on the MMC comprise all parameters and MLD programs required for restoring a device configuration. The device configuration is restored by means of cross communication (CCD) in the CCD slaves.

See also Functional Description of firmware "MultiMediaCard (MMC)"

C6600 - Attributes Display: C66
 Ident N°: C6600

10.1.63 C7000 CCD: Command adjust slave addresses

Allocation	Contained in 02VRS:	«-»	«-»	«-»	
	Contained in 03VRS:	«-»	«-»	«-»	
	Contained in 04VRS:	«-»	«-»	«-»	
	Contained in 05VRS:	«-»	«MPH»	«-»	
	Contained in 06VRS:	«-»	«-»	«-»	«MPC»
	Contained in 07VRS:	«-»	«-»	«-»	«MPC»
	Contained in 08VRS:	«-»	«-»	«-»	«MPC»
	Supported by supply unit:	«-»			

The command for adjusting the slave addresses ("P-0-1635, C7000 CCD: Command Adjust slave addresses") was activated.

See also Functional Description of firmware "Cross Communication (CCD)"

C7000 - Attributes Display: C70
 Ident N°: C7000

10.1.64 C7100 CCD: Command Close ring

Allocation	Contained in 02VRS:	«-»	«-»	«-»	
	Contained in 03VRS:	«-»	«-»	«-»	
	Contained in 04VRS:	«-»	«-»	«-»	
	Contained in 05VRS:	«-»	«-»	«-»	
	Contained in 06VRS:	«-»	«-»	«-»	«MPC»
	Contained in 07VRS:	«-»	«-»	«-»	«MPC»
	Contained in 08VRS:	«-»	«-»	«-»	«MPC»
	Supported by supply unit:	«-»			

If "P-0-1620.0.3, CCD: Command topology"="4" (double ring), the CCD master can close the line or 2 lines with command P-0-1620.0.21 (C7100) to form a double ring.

See also Functional Description of firmware "Cross Communication (CCD)"

C7100 - Attributes Display: C71
 Ident N°: C7100

10.1.65 C7200 CCD: Command Apply I/O configuration

Allocation	Contained in 02VRS:	«-»	«-»	«-»	
	Contained in 03VRS:	«-»	«-»	«-»	
	Contained in 04VRS:	«-»	«-»	«-»	
	Contained in 05VRS:	«-»	«-»	«-»	
	Contained in 06VRS:	«-»	«-»	«-»	«-»
	Contained in 07VRS:	«-»	«-»	«-»	«-»
	Contained in 08VRS:	«-»	«-»	«-»	«MPC»
	Supported by supply unit:	«-»			

The command for applying the CCD I/O configuration (P-0-1620.0.31, C7200 CCD: Command Apply I/O configuration) was started.

See also Functional Description of firmware "Cross Communication (CCD)"

Diagnostic Command Messages

10.2 Command Errors

10.2.1 Clearing Command Errors

A command error cannot be removed by "clearing errors", but only by completing the corresponding command.

10.2.2 C0101 Invalid parameters (-> S-0-0021)

Allocation	Contained in 02VRS:	«MPB»	«MPH»	«MPD»	
	Contained in 03VRS:	«MPB»	«MPH»	«MPD»	
	Contained in 04VRS:	«MPB»	«MPH»	«MPD»	
	Contained in 05VRS:	«MPB»	«MPH»	«MPD»	
	Contained in 06VRS:	«MPB»	«MPH»	«MPD»	«MPC»
	Contained in 07VRS:	«MPB»	«MPH»	«MPD»	«MPC»
	Contained in 08VRS:	«MPB»	«MPH»	«MPD»	«MPC»
	Supported by supply unit:	«HMV»			

While command "S-0-0127, C0100 Communication phase 3 transition check" is executed, internal variables are initialized and the available parameters are checked (e.g. for validity). An error was detected during execution of the command.

Cause	Remedy
Data block elements required in communication phase 3 are missing or invalid	Write allowed operating data to parameters affected. (Affected parameters can be taken from list "S-0-0021, IDN-list of invalid operation data for CP2")
A change was made in "P-0-2003, Selection of functional packages". Then you failed to reboot before trying to switch to operating mode.	Check content of "P-0-2003, Selection of functional packages" and reboot (i.e., switch device off and on again)
A change of functional packages was made in "P-0-2003, Selection of functional packages" which has an effect on customer- and application-specific parameters lists (e.g., S-0-0279)	Correct list parameters affected. (Affected parameters can be taken from list "S-0-0021, IDN-list of invalid operation data for CP2".) Problem can also be remedied by loading basic parameters ("S-0-0262, C07_x Load defaults procedure command" with appropriate setting in "P-0-4090, Configuration for loading default values")
Internal data memory defective	Contact our service department

For removing command errors see "Command Errors"

C0101 - Attributes	Display:	C0101
	Ident N°:	C0101

10.2.3 C0102 Limit error in parameter (-> S-0-0021)

Allocation	Contained in 02VRS:	«MPB»	«MPH»	«MPD»	
	Contained in 03VRS:	«MPB»	«MPH»	«MPD»	
	Contained in 04VRS:	«MPB»	«MPH»	«MPD»	
	Contained in 05VRS:	«MPB»	«MPH»	«MPD»	
	Contained in 06VRS:	«MPB»	«MPH»	«MPD»	«MPC»
	Contained in 07VRS:	«MPB»	«MPH»	«MPD»	«MPC»
	Contained in 08VRS:	«MPB»	«MPH»	«MPD»	«MPC»
	Supported by supply unit:	«HMV»			

While the command "S-0-0127, C0100 Communication phase 3 transition check" is executed, the limit values (minimum/maximum value) are checked for some parameters. An error was detected during the execution of the command.

Diagnostic Command Messages

Cause	Remedy
Parameter values required in communication phase 3 are outside their allowed range of values (minimum or maximum value)	Write allowed values to parameters (cf. minimum/maximum value) (these parameters can be taken from list "S-0-0021, IDN list of invalid operating data for communication phase 2")

For removing command errors see "Command Errors"

C0102 - Attributes Display: C0102
 Ident N°: C0102

10.2.4 C0103 Parameter conversion error (->S-0-0021)

Allocation	Contained in 02VRS:	«MPB»	«MPH»	«MPD»	
	Contained in 03VRS:	«MPB»	«MPH»	«MPD»	
	Contained in 04VRS:	«MPB»	«MPH»	«MPD»	
	Contained in 05VRS:	«MPB»	«MPH»	«MPD»	
	Contained in 06VRS:	«MPB»	«MPH»	«MPD»	«MPC»
	Contained in 07VRS:	«MPB»	«MPH»	«MPD»	«MPC»
	Contained in 08VRS:	«MPB»	«MPH»	«MPD»	«MPC»
	Supported by supply unit:	«-»			

While the command "S-0-0127, C0100 Communication phase 3 transition check" is executed, the internal parameter formats are checked in order to ensure the internal processing. An error was detected during the execution of the command.

Cause	Remedy
Parameter values required in communication phase 3 cannot be processed	Write allowed values to parameters (these parameters can be taken from list "S-0-0021, IDN list of invalid operating data for communication phase 2")

For removing command errors see "Command Errors"

C0103 - Attributes Display: C0103
 Ident N°: C0103

10.2.5 C0104 Config. IDN for MDT not configurable

Allocation	Contained in 02VRS:	«MPB»	«MPH»	«MPD»	
	Contained in 03VRS:	«MPB»	«MPH»	«MPD»	
	Contained in 04VRS:	«MPB»	«MPH»	«MPD»	
	Contained in 05VRS:	«MPB»	«MPH»	«MPD»	
	Contained in 06VRS:	«MPB»	«MPH»	«MPD»	«MPC»
	Contained in 07VRS:	«MPB»	«MPH»	«MPD»	«MPC»
	Contained in 08VRS:	«MPB»	«MPH»	«MPD»	«MPC»
	Supported by supply unit:	«-»			

During the transition check from communication phase 2 to communication phase 3 (C0100) an error with regard to the telegram configuration of the master communication was detected.

Cause	Remedy
In "S-0-0015, Telegram type parameter", telegram type 7 (configured telegram) was set	Set priority telegram (telegram type = 0..6) in "S-0-0015, Telegram type parameter"
In "S-0-0024, Config. list of the master data telegram" there were some parameters entered that are not contained in "S-0-0188, List of configurable data in the MDT"	In "S-0-0024, Config. list of the master data telegram" those parameters have to be entered that are contained in "S-0-0188, List of configurable data in the MDT"



List parameters are only allowed in the multiplex channel.

Diagnostic Command Messages

C0104 - Attributes **Display:** C0104
Ident N°: C0104

10.2.6 C0105 Maximum length for MDT exceeded

Allocation	Contained in 02VRS:	«MPB»	«MPH»	«MPD»	
	Contained in 03VRS:	«MPB»	«MPH»	«MPD»	
	Contained in 04VRS:	«MPB»	«MPH»	«MPD»	
	Contained in 05VRS:	«MPB»	«MPH»	«MPD»	
	Contained in 06VRS:	«MPB»	«MPH»	«MPD»	«MPC»
	Contained in 07VRS:	«MPB»	«MPH»	«MPD»	«MPC»
	Contained in 08VRS:	«MPB»	«MPH»	«MPD»	«MPC»
	Supported by supply unit:	«-»			

During the execution of the command "S-0-0127, C0100 Communication phase 3 transition check" an error with regard to the telegram configuration of the master communication was detected.

Cause	Remedy
In "S-0-0015, Telegram type parameter", telegram type 7 (configured telegram) was set	Set priority telegram (telegram type = 0..6) in "S-0-0015, Telegram type parameter"
Length of configured data record in MDT that is determined by "S-0-0024, Config. list of the master data telegram" exceeds the maximum allowed value entered in "S-0-0186, Length of the configurable data record in the MDT"	Reduce number of configured parameters in MDT ("S-0-0024, Config. list of the master data telegram")



List parameters are only allowed in the multiplex channel.

For removing command errors see "Command Errors"

C0105 - Attributes **Display:** C0105
Ident N°: C0105

10.2.7 C0106 Config. IDNs for AT not configurable

Allocation	Contained in 02VRS:	«MPB»	«MPH»	«MPD»	
	Contained in 03VRS:	«MPB»	«MPH»	«MPD»	
	Contained in 04VRS:	«MPB»	«MPH»	«MPD»	
	Contained in 05VRS:	«MPB»	«MPH»	«MPD»	
	Contained in 06VRS:	«MPB»	«MPH»	«MPD»	«MPC»
	Contained in 07VRS:	«MPB»	«MPH»	«MPD»	«MPC»
	Contained in 08VRS:	«MPB»	«MPH»	«MPD»	«MPC»
	Supported by supply unit:	«-»			

During the transition check from communication phase 2 to communication phase 3 (C0100) an error with regard to the telegram configuration of the master communication was detected.

Cause	Remedy
In "S-0-0015, Telegram type parameter", telegram type 7 (configured telegram) was set	Set priority telegram (telegram type = 0..6) in "S-0-0015, Telegram type parameter"
In "S-0-0016, Custom amplifier telegram configuration list" there were some parameters entered that are not contained in "S-0-0187, List of configurable data in the AT"	In "S-0-0016, Custom amplifier telegram configuration list" those parameters have to be entered that are contained in "S-0-0187, List of configurable data in the AT"



List parameters are only allowed in the multiplex channel.

C0106 - Attributes **Display:** C0106
 Ident N°: C0106

10.2.8 C0107 Maximum length for AT exceeded

Allocation	Contained in 02VRS:	«MPB»	«MPH»	«MPD»	
	Contained in 03VRS:	«MPB»	«MPH»	«MPD»	
	Contained in 04VRS:	«MPB»	«MPH»	«MPD»	
	Contained in 05VRS:	«MPB»	«MPH»	«MPD»	
	Contained in 06VRS:	«MPB»	«MPH»	«MPD»	«MPC»
	Contained in 07VRS:	«MPB»	«MPH»	«MPD»	«MPC»
	Contained in 08VRS:	«MPB»	«MPH»	«MPD»	«MPC»
	Supported by supply unit:	«-»			

During the transition check from communication phase 2 to communication phase 3 (C0100) an error with regard to the telegram configuration of the master communication was detected.

Cause	Remedy
In "S-0-0015, Telegram type parameter", telegram type 7 (configured telegram) was set	Set priority telegram (telegram type = 0..6) in "S-0-0015, Telegram type parameter"
Length of configured data record in AT that is determined by "S-0-0016, Custom amplifier telegram configuration list", exceeds maximum allowed value entered in "S-0-0185, Length of the configurable data record in the AT"	Reduce number of configured parameters in AT in "S-0-0016, Custom amplifier telegram configuration list"

C0107 - Attributes **Display:** C0107
 Ident N°: C0107

10.2.9 C0108 Time slot parameter > Sercos cycle time

Allocation	Contained in 02VRS:	«MPB»	«MPH»	«MPD»	
	Contained in 03VRS:	«MPB»	«MPH»	«MPD»	
	Contained in 04VRS:	«MPB»	«MPH»	«MPD»	
	Contained in 05VRS:	«MPB»	«MPH»	«MPD»	
	Contained in 06VRS:	«MPB»	«MPH»	«MPD»	«MPC»
	Contained in 07VRS:	«MPB»	«MPH»	«MPD»	«MPC»
	Contained in 08VRS:	«MPB»	«MPH»	«MPD»	«MPC»
	Supported by supply unit:	«-»			

While the command "S-0-0127, C0100 Communication phase 3 transition check" is executed, the timing settings for SERCOS communication are checked. An error was detected during the execution of the command.

Diagnostic Command Messages

Cause	Remedy
SERCOS II: At least one of the following time slot parameters exceeds SERCOS cycle time ["S-0-0002, SERCOS Cycle time (TScyc)"]: <ul style="list-style-type: none"> S-0-0006, AT Transmission starting time (T1) S-0-0007, Feedback acquisition starting time (T4) S-0-0008, Command valid time (T3) S-0-0089, MDT Transmit starting time (T2) 	Correct the respective time slot parameter(s). Contact machine manufacturer or installation programmer
SERCOS III: At least one of the following time slot parameters is not correct: <ul style="list-style-type: none"> S-0-1006, SERCOS III: AT0 transmission starting time (t1) S-0-1007, SERCOS III: Feedback acquisition starting time (t4) S-0-1017, SERCOS III: NRT transmission time 	Correct the respective time slot parameter(s). Contact machine manufacturer or installation programmer



The definition of the times for the time slot parameters is the responsibility of the control unit manufacturer and is specified by SERCOS interface.

For removing command errors see "Command Errors"

C0108 - Attributes **Display:** C0108
Ident N°: C0108

10.2.10 C0109 Telegram offset unsuitable

Allocation	Contained in 02VRS:	«MPB»	«MPH»	«MPD»	
	Contained in 03VRS:	«MPB»	«MPH»	«MPD»	
	Contained in 04VRS:	«MPB»	«MPH»	«MPD»	
	Contained in 05VRS:	«MPB»	«MPH»	«MPD»	
	Contained in 06VRS:	«MPB»	«MPH»	«MPD»	«MPC»
	Contained in 07VRS:	«MPB»	«MPH»	«MPD»	«MPC»
	Contained in 08VRS:	«MPB»	«MPH»	«MPD»	«MPC»
	Supported by supply unit:	«-»			

During the execution of the command "S-0-0127, C0100 Communication phase 3 transition check" an error was detected.

Diagnostic Command Messages

10.2.12 C0111 ID9 + Record length - 1 > length MDT (S-0-0010)

Allocation	Contained in 02VRS:	«MPB»	«MPH»	«MPD»	
	Contained in 03VRS:	«MPB»	«MPH»	«MPD»	
	Contained in 04VRS:	«MPB»	«MPH»	«MPD»	
	Contained in 05VRS:	«MPB»	«MPH»	«MPD»	
	Contained in 06VRS:	«MPB»	«MPH»	«MPD»	«MPC»
	Contained in 07VRS:	«MPB»	«MPH»	«MPD»	«MPC»
	Contained in 08VRS:	«MPB»	«MPH»	«MPD»	«MPC»
	Supported by supply unit:	«-»			

During the execution of the command "S-0-0127, C0100 Communication phase 3 transition check" an error was detected.

The position of the data record in the master data telegram (MDT) (S-0-0009) plus the length of the data record in the MDT for the drive is greater than the total length of the MDT (S-0-0010).

Cause	Remedy
Parameterization of "S-0-0009, Position of data record in MDT" and "S-0-0010, Length of master data telegram" is incorrect	Correct parameterization of "S-0-0009, Position of data record in MDT" and "S-0-0010, Length of master data telegram"



The definition of the S-0-0009 and S-0-0010 parameters is the responsibility of the control unit manufacturer and is specified by SERCOS.

C0111 - Attributes	Display:	C0111
	Ident N°:	C0111

10.2.13 C0112 TNcyc (S-0-0001) or TScyc (S-0-0002) error

Allocation	Contained in 02VRS:	«MPB»	«MPH»	«MPD»	
	Contained in 03VRS:	«MPB»	«MPH»	«MPD»	
	Contained in 04VRS:	«MPB»	«MPH»	«MPD»	
	Contained in 05VRS:	«MPB»	«MPH»	«MPD»	
	Contained in 06VRS:	«MPB»	«MPH»	«MPD»	«MPC»
	Contained in 07VRS:	«MPB»	«MPH»	«MPD»	«MPC»
	Contained in 08VRS:	«MPB»	«MPH»	«MPD»	«MPC»
	Supported by supply unit:	«-»			

During the execution of the command "S-0-0127, C0100 Communication phase 3 transition check" an error with regard to the SERCOS timing settings was detected.

Cause	Remedy
Setting of parameters "S-0-0001, NC Cycle time (TNcyc)" or "S-0-0002, SERCOS Cycle time (TScyc)" is incorrect	Correct parameters "S-0-0001, NC Cycle time (TNcyc)" and "S-0-0002, SERCOS Cycle time (TScyc)". There are settings of 500 µs for control section ADVANCED (or 1 ms for control section BASIC) or integral multiples of 1 ms allowed.



The definition of the S-0-0001 and S-0-0002 parameters is the responsibility of the control unit manufacturer and is specified by SERCOS.

For removing command errors see "Command Errors"

C0112 - Attributes **Display:** C0112
 Ident N°: C0112

10.2.14 C0113 Relation TNcyc (S-0-0001) to TScyc (S-0-0002) error

Allocation	Contained in 02VRS:	«MPB»	«MPH»	«MPD»	
	Contained in 03VRS:	«MPB»	«MPH»	«MPD»	
	Contained in 04VRS:	«MPB»	«MPH»	«MPD»	
	Contained in 05VRS:	«MPB»	«MPH»	«MPD»	
	Contained in 06VRS:	«MPB»	«MPH»	«MPD»	«MPC»
	Contained in 07VRS:	«MPB»	«MPH»	«MPD»	«MPC»
	Contained in 08VRS:	«MPB»	«MPH»	«MPD»	«MPC»
	Supported by supply unit:	«-»			

During the execution of the command "S-0-0127, C0100 Communication phase 3 transition check" an error with regard to the SERCOS timing settings was detected.

Cause	Remedy
Setting of parameters "S-0-0001, NC Cycle time (TNcyc)" or "S-0-0002, SERCOS Cycle time (TScyc)" is incorrect	Value of "S-0-0001, NC Cycle time (TNcyc)" can only be equal to or a multiple of "S-0-0002, SERCOS Cycle time (TScyc)". Correct parameters "S-0-0001, NC Cycle time (TNcyc)" and "S-0-0002, SERCOS Cycle time (TScyc)".



The definition of the S-0-0001 and S-0-0002 parameters is the responsibility of the control unit manufacturer and is specified by SERCOS.

For removing command errors see "Command Errors"

C0113 - Attributes **Display:** C0113
 Ident N°: C0113

10.2.15 C0114 T4 > TScyc (S-0-0002) - T4min (S-0-0005)

Allocation	Contained in 02VRS:	«MPB»	«MPH»	«MPD»	
	Contained in 03VRS:	«MPB»	«MPH»	«MPD»	
	Contained in 04VRS:	«MPB»	«MPH»	«MPD»	
	Contained in 05VRS:	«MPB»	«MPH»	«MPD»	
	Contained in 06VRS:	«MPB»	«MPH»	«MPD»	«MPC»
	Contained in 07VRS:	«MPB»	«MPH»	«MPD»	«MPC»
	Contained in 08VRS:	«MPB»	«MPH»	«MPD»	«MPC»
	Supported by supply unit:	«-»			

During the execution of the command "S-0-0127, C0100 Communication phase 3 transition check" an error with regard to the SERCOS timing settings was detected.

Cause	Remedy
Value for "S-0-0007, Feedback acquisition starting time (T4)" is incorrect	Correct "S-0-0007, Feedback acquisition starting time (T4)". Maximum allowed value for "S-0-0007, Feedback acquisition starting time (T4)" is calculated from "S-0-0002, SERCOS cycle time (TScyc)" and "S-0-0005, Minimum feedback acquisition time (T4min)" as follows: S-0-0007 > S-0-0002 – S-0-0005

Diagnostic Command Messages



The definition of the S-0-0007 parameter is the responsibility of the control unit manufacturer and is specified by SERCOS.

For removing command errors see "Command Errors"

C0114 - Attributes Display: C0114
 Ident N°: C0114

10.2.16 C0115 T2 too small

Allocation	Contained in 02VRS:	«MPB»	«MPH»	«MPD»	
	Contained in 03VRS:	«MPB»	«MPH»	«MPD»	
	Contained in 04VRS:	«MPB»	«MPH»	«MPD»	
	Contained in 05VRS:	«MPB»	«MPH»	«MPD»	
	Contained in 06VRS:	«MPB»	«MPH»	«MPD»	«MPC»
	Contained in 07VRS:	«MPB»	«MPH»	«MPD»	«MPC»
	Contained in 08VRS:	«MPB»	«MPH»	«MPD»	«MPC»
	Supported by supply unit:	«-»			

During the execution of the command "S-0-0127, C0100 Communication phase 3 transition check" an error with regard to the SERCOS timing settings was detected.

Cause	Remedy
Value set for "S-0-0089, MDT Transmit starting time (T2)" is incorrect. Drive cannot run with this value	Correct "S-0-0089, MDT Transmit starting time (T2)"



The definition of the S-0-0089 parameter is the responsibility of the control unit manufacturer and is specified by SERCOS.

For removing command errors see "Command Errors"

C0115 - Attributes Display: C0115
 Ident N°: C0115

10.2.17 C0116 T3 (S-0-0008) within MDT (S-0-0089 + S-0-0010)

Allocation	Contained in 02VRS:	«MPB»	«MPH»	«MPD»	
	Contained in 03VRS:	«MPB»	«MPH»	«MPD»	
	Contained in 04VRS:	«MPB»	«MPH»	«MPD»	
	Contained in 05VRS:	«MPB»	«MPH»	«MPD»	
	Contained in 06VRS:	«MPB»	«MPH»	«MPD»	«MPC»
	Contained in 07VRS:	«MPB»	«MPH»	«MPD»	«MPC»
	Contained in 08VRS:	«MPB»	«MPH»	«MPD»	«MPC»
	Supported by supply unit:	«-»			

During the execution of the command "S-0-0127, C0100 Communication phase 3 transition check" an error with regard to the SERCOS timing settings was detected.

Cause	Remedy
Value for "S-0-0008, Command valid time (T3)" is within value for "S-0-0089, MDT Transmit starting time (T2)". This could cause access problems in SERCOS communication	Check and if necessary correct setting of "S-0-0089, MDT Transmit starting time (T2)" and "S-0-0008, Command valid time (T3)"



The definition of the SERCOS parameters is the responsibility of the control unit manufacturer and is specified by SERCOS.

For removing command errors see "Command Errors"

C0116 - Attributes **Display:** C0116
 Ident N°: C0116

10.2.18 C0118 Order of cyclic command value configuration incorrect

Allocation	Contained in 02VRS:	«-»	«-»	«-»	
	Contained in 03VRS:	«MPB»	«MPH»	«MPD»	
	Contained in 04VRS:	«-»	«-»	«-»	
	Contained in 05VRS:	«-»	«-»	«-»	
	Contained in 06VRS:	«MPB»	«MPH»	«MPD»	«MPC»
	Contained in 07VRS:	«MPB»	«MPH»	«MPD»	«MPC»
	Contained in 08VRS:	«MPB»	«MPH»	«MPD»	«MPC»
	Supported by supply unit:	«-»			

The chronology of the processing of cyclic command value data in the drive has the order with which the configured IDNs have been entered in parameter "S-0-0024, Config. list of the master data telegram". The following parameters are available for using multiplex mode in the cyclic command value telegram:

- "S-0-0360, Data container A: command value 1",
- "S-0-0362, Data container A: list index command values" and
- "S-0-0368, Data container A: Addressing"

If more than one of these parameters has been configured in the cyclic command value telegram, their correct order is checked in command "S-0-0127, C0100 Communication phase 3" transition check.

Cause	Remedy
Incorrect order of relevant parameters in cyclic command value telegram	Keep correct order of parameters in cyclic command value telegram: Parameters S-0-0362, S-0-0366 and S-0-0368 must precede parameters S-0-0360 and S-0-0450 to S-0-0456 in cyclic command value telegram

See also Functional Description of firmware "Multiplex Channel"

C0118 - Attributes **Display:** C0118
 Ident N°: C0118

10.2.19 C0119 Max. travel range too large

Allocation	Contained in 02VRS:	«MPB»	«MPH»	«MPD»	
	Contained in 03VRS:	«-»	«-»	«-»	
	Contained in 04VRS:	«-»	«-»	«-»	
	Contained in 05VRS:	«-»	«-»	«-»	
	Contained in 06VRS:	«-»	«-»	«-»	«-»
	Contained in 07VRS:	«-»	«-»	«-»	«-»
	Contained in 08VRS:	«-»	«-»	«-»	«-»
	Supported by supply unit:	«-»			

During the transition check from communication phase 2 to communication phase 3 (C0100) an error with regard to the scaling of the drive was detected.

Diagnostic Command Messages

Cause	Remedy
"S-0-0278, Maximum travel range" incorrectly parameterized. Defined travel range is too large	Check and, if necessary, reduce parameterization of S-0-0278. The value of "S-0-0278, Maximum travel range" is to be selected in such a way that the resulting internal position resolution guarantees a correct commutation of the motor.
Inappropriate measuring system (resolution) for maximum travel range to be displayed	Check resolution of measuring system and, if necessary, use a different measuring system

For removing command errors see "Command Errors"

See also Functional Description of firmware "Scaling"

C0119 - Attributes **Display:** C0119
 Ident N°: C0119

10.2.20 C0120 Error when reading encoder data => motor encoder

Allocation	Contained in 02VRS:	«MPB»	«MPH»	«MPD»	
	Contained in 03VRS:	«-»	«-»	«-»	
	Contained in 04VRS:	«-»	«-»	«-»	
	Contained in 05VRS:	«-»	«-»	«-»	
	Contained in 06VRS:	«-»	«-»	«-»	«-»
	Contained in 07VRS:	«-»	«-»	«-»	«-»
	Contained in 08VRS:	«-»	«-»	«-»	«-»
	Supported by supply unit:	«-»			

During the transition check from communication phase 2 to communication phase 3 (C0100) an error during the reading of the encoder data from the data memory of the motor encoder was detected.



Measuring systems with their own data memory are DSF/HSF and resolvers, as well as measuring systems with EnDat interface (Heidenhain company) and HIPERFACE® interface (Stegmann company).

Cause	Remedy
Measuring system cable defective	Check measuring system cable
Measuring system defective	Replace measuring system
Encoder interface card defective	Replace encoder interface card

C0120 - Attributes **Display:** C0120
 Ident N°: C0120

10.2.21 C0121 Incorrect parameterization of motor encoder (hardware)

Allocation	Contained in 02VRS:	«MPB»	«MPH»	«MPD»	
	Contained in 03VRS:	«-»	«-»	«-»	
	Contained in 04VRS:	«-»	«-»	«-»	
	Contained in 05VRS:	«-»	«-»	«-»	
	Contained in 06VRS:	«-»	«-»	«-»	«-»
	Contained in 07VRS:	«-»	«-»	«-»	«-»
	Contained in 08VRS:	«-»	«-»	«-»	«-»
	Supported by supply unit:	«-»			

During the transition check from communication phase 2 to communication phase 3 (C0100) an error with regard to the parameterization of the motor encoder hardware was detected.

Diagnostic Command Messages

Cause	Remedy
Parameterization "P-0-0074, Encoder type 1 (motor encoder)" does not match encoder interface (e.g. EN1 with EnDat encoder)	Check whether parameterized encoder type matches encoder interface
In the case of "current control with motor encoder" (see "P-0-0045, Control word of current controller"), "operation without encoder" was detected to have been set in "P-0-0074, Encoder type 1 (motor encoder)"	Enter value appropriate for motor encoder in "P-0-0074, Encoder type 1 (motor encoder)"
Parameterization in "P-0-0077, Assignment motor encoder->optional slot" is incorrect	Correct assignment of motor encoder and optional slot in parameter "P-0-0077, Assignment motor encoder->optional slot"

C0121 - Attributes **Display:** C0121
 Ident N°: C0121

10.2.22 C0122 Incorr. parameteriz. of motor enc. (mechanical system)

Allocation	Contained in 02VRS:	«MPB»	«MPH»	«MPD»	
	Contained in 03VRS:	«-»	«-»	«-»	
	Contained in 04VRS:	«-»	«-»	«-»	
	Contained in 05VRS:	«-»	«-»	«-»	
	Contained in 06VRS:	«-»	«-»	«-»	«-»
	Contained in 07VRS:	«-»	«-»	«-»	«-»
	Contained in 08VRS:	«-»	«-»	«-»	«-»
	Supported by supply unit:	«-»			

During the transition check from communication phase 2 to communication phase 3 (C0100) an error was detected with regard to scaling that was set and the selected motor encoder type (e.g. rotary scaling with linear motor).

Cause	Remedy
Incorrect encoder type ("S-0-0277, Position feedback 1 type")	Check and, if necessary, correct "S-0-0277, Position feedback 1 type"
Parameterized scaling ("S-0-0076, Position data scaling type") is incorrect	Check and, if necessary, correct "S-0-0076, Position data scaling type"

For removing command errors see "Command Errors"

C0122 - Attributes **Display:** C0122
 Ident N°: C0122

10.2.23 C0123 Modulo value for motor encoder cannot be displayed

Allocation	Contained in 02VRS:	«MPB»	«MPH»	«MPD»	
	Contained in 03VRS:	«-»	«-»	«-»	
	Contained in 04VRS:	«-»	«-»	«-»	
	Contained in 05VRS:	«-»	«-»	«-»	
	Contained in 06VRS:	«-»	«-»	«-»	«-»
	Contained in 07VRS:	«-»	«-»	«-»	«-»
	Contained in 08VRS:	«-»	«-»	«-»	«-»
	Supported by supply unit:	«-»			

During the transition check from communication phase 2 to communication phase 3 (C0100) an error with regard to the modulo value for the motor encoder was detected.

Diagnostic Command Messages

Cause	Remedy
Parameterized value for "S-0-0103, Modulo value" is greater than maximum travel range (cf. "S-0-0278, Maximum travel range")	Correct content of "S-0-0103, Modulo value" or value of "S-0-0278, Maximum travel range"
Parameterized value for "S-0-0103, Modulo value" cannot be internally displayed with gear ratios that have been set (S-0-0121/S-0-0122, P-0-0121/P-0-0122)	Correct content of "S-0-0103, Modulo value" or gear ratios that have been set ["S-0-0121, Input revolutions of load gear"/"S-0-0122, Output revolutions of load gear"; "P-0-0121, Gear 1 motor-side (motor encoder)"/"P-0-0122, Gear 1 encoder-side (motor encoder)"]

For removing command errors see "Command Errors"

C0123 - Attributes **Display:** C0123
 Ident N°: C0123

10.2.24 C0124 Motor encoder unknown

Allocation	Contained in 02VRS:	«MPB»	«MPH»	«MPD»
	Contained in 03VRS:	«-»	«-»	«-»
	Contained in 04VRS:	«-»	«-»	«-»
	Contained in 05VRS:	«-»	«-»	«-»
	Contained in 06VRS:	«-»	«-»	«-»
	Contained in 07VRS:	«-»	«-»	«-»
	Contained in 08VRS:	«-»	«-»	«-»
	Supported by supply unit:	«-»		

During the transition check from communication phase 2 to communication phase 3 (C0100) an error with regard to the motor encoder was detected. The content of "P-0-1000, Kind of encoder 1, encoder memory" is invalid and therefore the parameterized motor encoder is not allowed (e.g. rotary scaling with linear encoder).

Cause	Remedy
Encoder memory (feedback) is defective	Encoder (or motor) must be replaced
Kind of motor encoder ("P-0-1000, Kind of encoder 1, encoder memory") is not supported by firmware	Check content of "P-0-1000, Kind of encoder 1, encoder memory" and contact our service department
Detected kind of encoder does not match parameterized type of encoder	Check control section configuration and, if necessary, replace control section by a correctly configured control section or replace complete drive controller



Only Rexroth service engineers or especially trained users are allowed to replace the control section. The replacement of the entire drive controller is described in the Project Planning Manual for the power section.

For removing command errors see "Command Errors"

C0124 - Attributes **Display:** C0124
 Ident N°: C0124

10.2.25 C0125 Error when reading encoder data => optional encoder

Allocation	Contained in 02VRS:	«MPB»	«MPH»	«MPD»	
	Contained in 03VRS:	«-»	«-»	«-»	
	Contained in 04VRS:	«-»	«-»	«-»	
	Contained in 05VRS:	«-»	«-»	«-»	
	Contained in 06VRS:	«-»	«-»	«-»	«-»
	Contained in 07VRS:	«-»	«-»	«-»	«-»
	Contained in 08VRS:	«-»	«-»	«-»	«-»
	Supported by supply unit:	«-»			

During the transition check from communication phase 2 to communication phase 3 (C0100) an error during the reading of the encoder data from the data memory of the optional encoder was detected.



Measuring systems with their own data memory are DSF/HSF and resolvers, as well as measuring systems with EnDat interface (Heidenhain company) and HIPERFACE® interface (Stegmann company).

Cause	Remedy
Measuring system cable defective	Check measuring system cable
Measuring system defective	Replace measuring system
Encoder interface defective	Replace control section or entire drive controller



Only Rexroth service engineers or especially trained users are allowed to replace the control section. The replacement of the entire drive controller is described in the Project Planning Manual for the power section.

C0125 - Attributes Display: C0125
 Ident N°: C0125

10.2.26 C0126 Incorrect parameterization of optional enc. (hardware)

Allocation	Contained in 02VRS:	«MPB»	«MPH»	«MPD»	
	Contained in 03VRS:	«-»	«-»	«-»	
	Contained in 04VRS:	«-»	«-»	«-»	
	Contained in 05VRS:	«-»	«-»	«-»	
	Contained in 06VRS:	«-»	«-»	«-»	«-»
	Contained in 07VRS:	«-»	«-»	«-»	«-»
	Contained in 08VRS:	«-»	«-»	«-»	«-»
	Supported by supply unit:	«-»			

During the transition check from communication phase 2 to communication phase 3 (C0100) an error with regard to the parameterization of the hardware of the optional encoder was detected.

Cause	Remedy
Parameterization "P-0-0075, Encoder type 2 (optional encoder)" does not match interface card (e.g. EN1 with EnDat encoder)	Correct parameterization of "P-0-0075, Encoder type 2 (optional encoder)"
"P-0-0078, Assignment optional encoder->optional slot" incorrect	Correct parameterization of "P-0-0078, Assignment optional encoder->optional slot"

See also Functional Description of firmware "Measurement Systems"

Diagnostic Command Messages

C0126 - Attributes **Display:** C0126
Ident N°: C0126

10.2.27 C0127 Incorr. parameteriz. of opt. enc. (mechanical system)

Allocation	Contained in 02VRS:	«MPB»	«MPH»	«MPD»	
	Contained in 03VRS:	«-»	«-»	«-»	
	Contained in 04VRS:	«-»	«-»	«-»	
	Contained in 05VRS:	«-»	«-»	«-»	
	Contained in 06VRS:	«-»	«-»	«-»	«-»
	Contained in 07VRS:	«-»	«-»	«-»	«-»
	Contained in 08VRS:	«-»	«-»	«-»	«-»
	Supported by supply unit:	«-»			

During the transition check from communication phase 2 to communication phase 3 (C0100) an error was detected with regard to scaling that was set and the selected motor encoder type (e.g. rotary scaling with linear optional encoder).

Cause	Remedy
Incorrect encoder type ("S-0-0115, Position feedback 2 type")	Check and, if necessary, correct "S-0-0115, Position feedback 2 type"
Parameterized scaling ("S-0-0076, Position data scaling type") is incorrect	Check and, if necessary, correct "S-0-0076, Position data scaling type"

For removing command errors see "Command Errors"

C0127 - Attributes **Display:** C0127
Ident N°: C0127

10.2.28 C0128 Modulo value for optional encoder cannot be displayed

Allocation	Contained in 02VRS:	«MPB»	«MPH»	«MPD»	
	Contained in 03VRS:	«-»	«-»	«-»	
	Contained in 04VRS:	«-»	«-»	«-»	
	Contained in 05VRS:	«-»	«-»	«-»	
	Contained in 06VRS:	«-»	«-»	«-»	«-»
	Contained in 07VRS:	«-»	«-»	«-»	«-»
	Contained in 08VRS:	«-»	«-»	«-»	«-»
	Supported by supply unit:	«-»			

During the transition check from communication phase 2 to communication phase 3 (C0100) an error with regard to the modulo value for the optional encoder was detected.

Cause	Remedy
Parameterized value for "S-0-0103, Modulo value" is greater than maximum travel range (cf. "S-0-0278, Maximum travel range")	Correct content of "S-0-0103, Modulo value" or value of "S-0-0278, Maximum travel range"
Parameterized value for "S-0-0103, Modulo value" cannot be internally displayed with the gear ratios that have been set (S-0-0121/S-0-0122, P-0-0121/P-0-0122)	Correct content of "S-0-0103, Modulo value" or gear ratios that have been set ["S-0-0121, Input revolutions of load gear"/"S-0-0122, Output revolutions of load gear"; "P-0-0121, Gear 1 motor-side (motor encoder)"/"P-0-0122, Gear 1 encoder-side (motor encoder)"]
Encoder resolution ("S-0-0117, Feedback 2 Resolution") incorrectly parameterized	Check and, if necessary, correct parameterization of "S-0-0117, Feedback 2 Resolution"
Resolution of encoder does not match required modulo range	Replace encoder

For removing command errors see "Command Errors"

See also Functional Description of firmware "Scaling"

C0128 - Attributes **Display:** C0128
 Ident N°: C0128

10.2.29 C0129 Optional encoder unknown

Allocation	Contained in 02VRS:	«MPB»	«MPH»	«MPD»	
	Contained in 03VRS:	«-»	«-»	«-»	
	Contained in 04VRS:	«-»	«-»	«-»	
	Contained in 05VRS:	«-»	«-»	«-»	
	Contained in 06VRS:	«-»	«-»	«-»	«-»
	Contained in 07VRS:	«-»	«-»	«-»	«-»
	Contained in 08VRS:	«-»	«-»	«-»	«-»
	Supported by supply unit:	«-»			

During the transition check from communication phase 2 to communication phase 3 (C0100) an error with regard to the optional encoder was detected. The content of "P-0-1010, Kind of encoder 2, encoder memory" is invalid and therefore the parameterized optional encoder is not allowed (e.g. rotary scaling with linear encoder).

Cause	Remedy
Encoder memory (feedback) is defective	Encoder must be replaced
Kind of motor encoder ("P-0-1010, Kind of encoder 2, encoder memory") is not supported by the firmware	Check content of "P-0-1010, Kind of encoder 2, encoder memory" and contact our service department
Detected kind of encoder does not match parameterized type of encoder	Check control section configuration and, if necessary, replace control section by a correctly configured control section or replace complete drive controller



Only Rexroth service engineers or especially trained users are allowed to replace the control section. The replacement of the entire drive controller is described in the Project Planning Manual for the power section.

For removing command errors see "Command Errors"

C0129 - Attributes **Display:** C0129
 Ident N°: C0129

10.2.30 C0130 Maximum travel range cannot be displayed internally

Allocation	Contained in 02VRS:	«MPB»	«MPH»	«MPD»	
	Contained in 03VRS:	«-»	«-»	«-»	
	Contained in 04VRS:	«-»	«-»	«-»	
	Contained in 05VRS:	«-»	«-»	«-»	
	Contained in 06VRS:	«-»	«-»	«-»	«-»
	Contained in 07VRS:	«-»	«-»	«-»	«-»
	Contained in 08VRS:	«-»	«-»	«-»	«-»
	Supported by supply unit:	«-»			

In the case of absolute scaling, the maximum travel range represents the overflow limit of the actual position values. If this travel range cannot be displayed correctly internally so that position generation without error is impossible, this error is generated.

Diagnostic Command Messages

Cause	Remedy
"S-0-0278, Maximum travel range" incorrectly parameterized	Check and if necessary reduce "S-0-0278, Maximum travel range"
S-0-0116 / S-0-0117 incorrectly set (e.g. value "0")	Check and if necessary correct "S-0-0116, Feedback 1 Resolution" / "S-0-0117, Feedback 2 Resolution"
Value for "S-0-0278, Maximum travel range" is invalid although it might be within the respective absolute encoder range	Check "S-0-0278, Maximum travel range" and if necessary change value (take respective absolute encoder range into account!)
Position resolution of a pole pair or of pole pair distance is too low. Commutation offset value internally cannot be displayed precisely enough	"P-0-0018, Number of pole pairs/pole pair distance" has value "0" or a too small value (maybe incorrect unit). Check and if necessary correct "P-0-0018, Number of pole pairs/pole pair distance"

See also Functional Description of firmware "Scaling"

For removing command errors see "Command Errors"

C0130 - Attributes Display: C0130
 Ident N°: C0130

10.2.31 C0131 Switching to phase 3 impossible

Allocation	Contained in 02VRS:	«MPB»	«MPH»	«MPD»	
	Contained in 03VRS:	«MPB»	«MPH»	«MPD»	
	Contained in 04VRS:	«MPB»	«MPH»	«MPD»	
	Contained in 05VRS:	«-»	«-»	«-»	
	Contained in 06VRS:	«-»	«-»	«-»	«-»
	Contained in 07VRS:	«-»	«-»	«-»	«-»
	Contained in 08VRS:	«-»	«-»	«-»	«-»
	Supported by supply unit:	«-»			

During the transition check from communication phase 2 to communication phase 3 (C0100) a forbidden attempt to switch to phase 3 was detected.

Cause	Remedy
During a firmware download there was an attempt to switch from communication phase 2 to communication phase 3	Wait until the firmware download is completed before switching to another communication phase
After a boot error (F81xx error) there was an attempt to switch from communication phase 2 to communication phase 3	Clear error, remove its cause and then boot up drive again

C0131 - Attributes Display: C0131
 Ident N°: C0131

10.2.32 C0132 Invalid settings for controller cycle times

Allocation	Contained in 02VRS:	«MPB»	«MPH»	«MPD»	
	Contained in 03VRS:	«MPB»	«MPH»	«MPD»	
	Contained in 04VRS:	«MPB»	«MPH»	«MPD»	
	Contained in 05VRS:	«MPB»	«MPH»	«MPD»	
	Contained in 06VRS:	«MPB»	«MPH»	«MPD»	«MPC»
	Contained in 07VRS:	«MPB»	«MPH»	«MPD»	«MPC»
	Contained in 08VRS:	«MPB»	«MPH»	«MPD»	«MPC»
	Supported by supply unit:	«-»			

During the execution of the command "S-0-0127, C0100 Communication phase 3 transition check", an error in the parameterization of controller cycle times or PWM switching frequencies was detected.

Diagnostic Command Messages

P-0-0556, Config word of axis controller, bit 2	P-0-0001, Switching frequency of the power output stage	TA - position loop	TA - velocity loop	TA - current loop
0 (Basic)	16 kHz	500 µs	250 µs	62.5 µs
0 (Basic)	12 kHz	500 µs	250 µs	83.3 µs
0 (Basic)	8 kHz	500 µs	250 µs	125.0 µs
0 (Basic)	4 kHz	500 µs	250 µs	125.0 µs
0 (Basic)	2kHz	500 µs	250 µs	250.0 µs
1 (Advanced)	16 kHz	250 µs	125 µs	62.5 µs
1 (Advanced)	8 kHz	250 µs	125 µs	62.5 µs
1 (Advanced)	4 kHz	250 µs	125 µs	125.0 µs

TA Sampling time
 Fig. 10-2: Possible Controller Cycle Times Depending on Controller Performance and Switching Frequency That Have Been Set

Cause	Remedy
Parameterization of "P-0-0556, Config word of axis controller" does not comply with switching frequency of 12 kHz set in "P-0-0001, Switching frequency of the power output stage"	Select setting "Basic performance" (cf. bit 2) in "P-0-0556, Config word of axis controller"
Incorrect parameterization of switching frequency selected in "P-0-0001, Switching frequency of the power output stage" with given controller performance (= sampling rate/time)	In "P-0-0001, Switching frequency of the power output stage", select allowed switching frequency (see table)

See also Functional Description of firmware "Features of the Control Loops"
 For removing command errors see "Command Errors"

C0132 - Attributes Display: C0132
 Ident N°: C0132

10.2.33 C0134 Invalid motor data in encoder memory (->S-0-0021)

Allocation	Contained in 02VRS:	«MPB»	«MPH»	«MPD»	
	Contained in 03VRS:	«-»	«MPH»	«-»	
	Contained in 04VRS:	«-»	«-»	«-»	
	Contained in 05VRS:	«-»	«-»	«-»	
	Contained in 06VRS:	«-»	«-»	«-»	«-»
	Contained in 07VRS:	«-»	«-»	«-»	«-»
	Contained in 08VRS:	«-»	«-»	«-»	«-»
	Supported by supply unit:	«-»			

During the transition check from communication phase 2 to communication phase 3 (C0100) an error during the reading of the motor data from the data memory of the motor encoder was detected.

The respective parameters are entered in the "S-0-0021, IDN list of invalid operating data for communication phase 2" parameter.

Cause	Remedy
Measuring system cable defective	Check measuring system cable
Measuring system defective	Replace measuring system
Encoder interface defective	Replace control section or complete drive controller

Diagnostic Command Messages



Only Rexroth service engineers or especially trained users are allowed to replace the control section. The replacement of the entire drive controller is described in the Project Planning Manual for the power section.

For removing command errors see "Command Errors"

C0134 - Attributes
Display: C0134
Ident N°: C0134

10.2.34 C0135 Type of construction of motor P-0-4014 incorrect

Allocation	Contained in 02VRS:	«MPB»	«MPH»	«MPD»	
	Contained in 03VRS:	«-»	«-»	«-»	
	Contained in 04VRS:	«-»	«-»	«-»	
	Contained in 05VRS:	«-»	«-»	«-»	
	Contained in 06VRS:	«-»	«-»	«-»	«-»
	Contained in 07VRS:	«-»	«-»	«-»	«-»
	Contained in 08VRS:	«-»	«-»	«-»	«-»
	Supported by supply unit:	«-»			

During the execution of the command "S-0-0127, C0100 Communication phase 3 transition check" an error in the parameterization of the kind of motor was detected.

In "P-0-4014, Kind of motor" a motor with encoder data memory was parameterized but there wasn't any known motor type designation recognized in the encoder.

Cause	Remedy
A motor without encoder data memory was connected	Parameterize "P-0-4014, Kind of motor" correctly or connect a motor with encoder data memory
Encoder defective	Replace encoder

For removing command errors see "Command Errors"

C0135 - Attributes
Display: C0135
Ident N°: C0135

10.2.35 C0136 Several motor encoders connected

Allocation	Contained in 02VRS:	«MPB»	«MPH»	«MPD»	
	Contained in 03VRS:	«-»	«-»	«-»	
	Contained in 04VRS:	«-»	«-»	«-»	
	Contained in 05VRS:	«-»	«-»	«-»	
	Contained in 06VRS:	«-»	«-»	«-»	«-»
	Contained in 07VRS:	«-»	«-»	«-»	«-»
	Contained in 08VRS:	«-»	«-»	«-»	«-»
	Supported by supply unit:	«-»			

During the execution of the command "S-0-0127, C0100 Communication phase 3 transition check" two motor encoders were detected during the encoder configuration check.

Cause	Remedy
Two encoders were detected; in their data memories a valid and known motor type string is contained in "P-0-2141, Motor type, encoder memory"	Replace one of encoders by encoder without valid motor type string
Encoder connectors of neighboring axes were interchanged	Check axis assignment of encoder connectors and assign to correct axis

For removing command errors see "Command Errors"

Diagnostic Command Messages

10.2.38 C0139 T2 (S-0-0089)+length MDT (S-0-0010)>TScyc (S-0-0002)

Allocation	Contained in 02VRS:	«MPB»	«MPH»	«MPD»	
	Contained in 03VRS:	«MPB»	«MPH»	«MPD»	
	Contained in 04VRS:	«MPB»	«MPH»	«MPD»	
	Contained in 05VRS:	«MPB»	«MPH»	«MPD»	
	Contained in 06VRS:	«MPB»	«MPH»	«MPD»	«MPC»
	Contained in 07VRS:	«MPB»	«MPH»	«MPD»	«MPC»
	Contained in 08VRS:	«MPB»	«MPH»	«MPD»	«MPC»
	Supported by supply unit:	«-»			

During the execution of the command "S-0-0127, C0100 Communication phase 3 transition check" an error with regard to the timing setting of the SERCOS interface was detected. The phase switch to communication phase 3 is prevented.

Cause	Remedy
Sum of transmit starting time of master data telegram set by master ["S-0-0089, MDT Transmit starting time (T2)"] and length of data record of master data telegram ("S-0-0010, Length of master data telegram") exceeds SERCOS cycle time ["S-0-0002, SERCOS Cycle time (TScyc)"]. This means that master data telegram overlaps the master synchronization telegram (MST)	Parameterize smaller value for transmit starting time of master data telegram ["S-0-0089, MDT Transmit starting time (T2)"]

For removing command errors see "Command Errors"

C0139 - Attributes **Display:** C0139
 Ident N°: C0139

10.2.39 C0140 Rotary scaling not allowed

Allocation	Contained in 02VRS:	«MPB»	«MPH»	«MPD»	
	Contained in 03VRS:	«-»	«-»	«-»	
	Contained in 04VRS:	«-»	«-»	«-»	
	Contained in 05VRS:	«-»	«-»	«-»	
	Contained in 06VRS:	«-»	«-»	«-»	«-»
	Contained in 07VRS:	«-»	«-»	«-»	«-»
	Contained in 08VRS:	«-»	«-»	«-»	«-»
	Supported by supply unit:	«-»			

During the transition check from communication phase 2 to communication phase 3 (C0100) an error was detected with regard to scaling that was set and the selected motor type (e.g. rotary scaling although a linear motor is used). The phase switch to communication phase 3 is prevented.

Cause	Remedy
Although a linear motor is used, rotary scaling was selected in at least one of the following parameters: <ul style="list-style-type: none"> • S-0-0044, Velocity data scaling type • S-0-0076, Position data scaling type • S-0-0086, Torque/force data scaling type • S-0-0160, Acceleration data scaling type 	Check and correct respective scaling parameter(s) or use a linear encoder

For removing command errors see "Command Errors"

C0140 - Attributes **Display:** C0140
 Ident N°: C0140

10.2.40 C0151 IDN for command value data container not allowed

Allocation	Contained in 02VRS:	«-»	«-»	«-»	
	Contained in 03VRS:	«MPB»	«MPH»	«MPD»	
	Contained in 04VRS:	«-»	«-»	«-»	
	Contained in 05VRS:	«-»	«-»	«-»	
	Contained in 06VRS:	«MPB»	«MPH»	«MPD»	«MPC»
	Contained in 07VRS:	«MPB»	«MPH»	«MPD»	«MPC»
	Contained in 08VRS:	«MPB»	«MPH»	«MPD»	«MPC»
	Supported by supply unit:	«-»			

During the execution of the command "S-0-0127, C0100 Communication phase 3 transition check" an error with regard to the command value configuration list was detected. The phase switch to communication phase 3 is prevented.

Cause	Remedy
A command value configuration list (S-0-0370 and S-0-0490 to S-0-0496) contains one or several IDNs that aren't existing or not contained in "S-0-0188, List of configurable data in the MDT"	Check parameters "S-0-0370, Data container A: configuration list command value-1" and "S-0-0490, Data container A: configuration list command value 2" to "S-0-0496, Data container A: configuration list command value 8" for incorrect IDNs and correct them

For removing command errors see "Command Errors"

See also Functional Description of firmware "Multiplex Channel"

C0151 - Attributes	Display:	C0151
	Ident N°:	C0151

10.2.41 C0152 IDN for actual value data container not allowed

Allocation	Contained in 02VRS:	«-»	«-»	«-»	
	Contained in 03VRS:	«MPB»	«MPH»	«MPD»	
	Contained in 04VRS:	«-»	«-»	«-»	
	Contained in 05VRS:	«-»	«-»	«-»	
	Contained in 06VRS:	«MPB»	«MPH»	«MPD»	«MPC»
	Contained in 07VRS:	«MPB»	«MPH»	«MPD»	«MPC»
	Contained in 08VRS:	«MPB»	«MPH»	«MPD»	«MPC»
	Supported by supply unit:	«-»			

During the execution of the command "S-0-0127, C0100 Communication phase 3 transition check" an error with regard to the actual value configuration list was detected. The phase switch to communication phase 3 is prevented.

Cause	Remedy
An actual value configuration list (S-0-0371 and S-0-0500 to S-0-0506) contains one or several IDNs that aren't existing or not contained in "S-0-0187, List of configurable data in the AT"	Check parameters "S-0-0371, Data container A: configuration list feedback value-1" and "S-0-0500, Data container A: configuration list feedback value 2" to "S-0-0506, Data container A: configuration list feedback value 8" for incorrect IDNs and correct them

For removing command errors see "Command Errors"

See also Functional Description of firmware "Multiplex Channel"

C0152 - Attributes	Display:	C0152
	Ident N°:	C0152

Diagnostic Command Messages

10.2.42 C0153 Error at init. of synchr. motor with reluctance torque

Allocation	Contained in 02VRS:	«MPB»	«MPH»	«MPD»	
	Contained in 03VRS:	«-»	«-»	«-»	
	Contained in 04VRS:	«-»	«-»	«-»	
	Contained in 05VRS:	«-»	«-»	«-»	
	Contained in 06VRS:	«-»	«-»	«-»	«-»
	Contained in 07VRS:	«-»	«-»	«-»	«-»
	Contained in 08VRS:	«-»	«-»	«-»	«-»
	Supported by supply unit:	«-»			

During the execution of the command "S-0-0127, C0100 Communication phase 3 transition check" a validation error was detected during the initialization of a synchronous motor with reluctance torque.



The initialization of a synchronous motor with reluctance torque is only run when this has been set in parameter "P-0-4014, Type of construction of motor".

The initialization of a synchronous motor implies the following parameters:

- S-0-0109, Motor peak current
- S-0-0110, Amplifier peak current
- S-0-0111, Motor current at standstill
- P-0-0018, Number of pole pairs/pole pair distance
- P-0-0051, Torque/force constant
- P-0-4002, Charact. of quadrature-axis induct. of motor, inductances
- P-0-4003, Charact. of quadrature-axis inductance of motor, currents
- P-0-4016, Direct-axis inductance of motor
- P-0-4017, Quadrature-axis inductance of motor

Cause	Remedy
Incomplete or invalid entries in parameters for initialization of synchronous motor	Check parameter contents and enter data supplied by motor manufacturer in above parameters. If error is generated in spite of correct data, please contact our service department
Initialization for synchronous motor with reluctance torque was run although synchronous motor without reluctance torque is used	Correct setting in "P-0-4014, Type of construction of motor"

See also Functional Description of firmware "Third-Party Motors at IndraDrive Controllers"

For removing command errors see "Command Errors"

C0153 - Attributes	Display:	C0153
	Ident N°:	C0153

10.2.43 C0154 Field bus: IDN for cycl. command val. not configurable

Allocation	Contained in 02VRS:	«MPB»	«MPH»	«MPD»	
	Contained in 03VRS:	«MPB»	«MPH»	«MPD»	
	Contained in 04VRS:	«-»	«-»	«-»	
	Contained in 05VRS:	«-»	«-»	«-»	
	Contained in 06VRS:	«-»	«-»	«-»	«-»
	Contained in 07VRS:	«-»	«-»	«-»	«-»
	Contained in 08VRS:	«-»	«-»	«-»	«-»
	Supported by supply unit:	«-»			

Diagnostic Command Messages

During the execution of the command "S-0-0127, C0100 Communication phase 3 transition check" an error with regard to the telegram configuration of the master communication was detected.

Cause	Remedy
In operating data of "P-0-4081, Field bus: config. list of cyclic command value data ch." there is an IDN that is not contained in "S-0-0188, List of configurable data in the MDT"	In "P-0-4081, Field bus: config. list of cyclic command value data ch." enter allowed IDN (cf. "S-0-0188, List of configurable data in the MDT")

For removing command errors see "Command Errors"

C0154 - Attributes Display: C0154
 Ident N°: C0154

10.2.44 C0155 Field bus: Max. length for cycl. command val. exceeded

Allocation	Contained in 02VRS:	«MPB»	«MPH»	«MPD»	
	Contained in 03VRS:	«MPB»	«MPH»	«MPD»	
	Contained in 04VRS:	«-»	«-»	«-»	
	Contained in 05VRS:	«-»	«-»	«-»	
	Contained in 06VRS:	«-»	«-»	«-»	«-»
	Contained in 07VRS:	«-»	«-»	«-»	«-»
	Contained in 08VRS:	«-»	«-»	«-»	«-»
	Supported by supply unit:	«-»			

During the transition check from communication phase 2 to communication phase 3 (C0100) an error with regard to the telegram configuration of the master communication was detected.

Cause	Remedy
Sum of data widths of all IDNs entered in "P-0-4081, Field bus: config. list of cyclic command value data ch." is exceeding max. value of "P-0-4071, Field bus: length of cyclic command value data channel"	Reduce number of IDNs entered in "P-0-4081, Field bus: config. list of cyclic command value data ch."

C0155 - Attributes Display: C0155
 Ident N°: C0155

10.2.45 C0156 Field bus: IDN for cycl. actual val. not configurable

Allocation	Contained in 02VRS:	«MPB»	«MPH»	«MPD»	
	Contained in 03VRS:	«MPB»	«MPH»	«MPD»	
	Contained in 04VRS:	«-»	«-»	«-»	
	Contained in 05VRS:	«-»	«-»	«-»	
	Contained in 06VRS:	«-»	«-»	«-»	«-»
	Contained in 07VRS:	«-»	«-»	«-»	«-»
	Contained in 08VRS:	«-»	«-»	«-»	«-»
	Supported by supply unit:	«-»			

During the execution of the command "S-0-0127, C0100 Communication phase 3 transition check" an error with regard to the telegram configuration of the master communication was detected.

Cause	Remedy
In operating data of "P-0-4080, Field bus: config. list of cyclic command value data ch." there is an IDN that is not contained in "S-0-0187, List of configurable data in the AT"	In "P-0-4080, Field bus: config. list of cyclic command value data ch." enter allowed IDNs (cf. "S-0-0187, List of configurable data in the AT")

 List parameters are only allowed in the multiplex channel.

For removing command errors see "Command Errors"

Diagnostic Command Messages

C0160 - Attributes **Display:** C0160
 Ident N°: C0160

10.2.50 C0161 Incorr. parameterization of measuring enc. (hardware)

Allocation	Contained in 02VRS:	«MPB»	«MPH»	«MPD»	
	Contained in 03VRS:	«-»	«-»	«-»	
	Contained in 04VRS:	«-»	«-»	«-»	
	Contained in 05VRS:	«-»	«-»	«-»	
	Contained in 06VRS:	«-»	«-»	«-»	«-»
	Contained in 07VRS:	«-»	«-»	«-»	«-»
	Contained in 08VRS:	«-»	«-»	«-»	«-»
	Supported by supply unit:	«-»			

During the transition check from communication phase 2 to communication phase 3 (C0100) an error with regard to the parameterization of the hardware of the measuring encoder was detected.

Cause	Remedy
Parameterization of "P-0-0076, Encoder type 3 (measuring encoder)" does not match encoder interface (e.g. EN1 with EnDat encoder)	Correct parameterization of "P-0-0076, Encoder type 3 (measuring encoder)"
"P-0-0079, Assignment measuring encoder ->optional slot" incorrectly parameterized	Correct parameterization of "P-0-0079, Assignment measuring encoder ->optional slot" or change control section configuration (replacement of control section or drive controller)
In the case of double-axis device (CDB control section) "P-0-0076, Encoder type 3 (measuring encoder)" was parameterized unequal "0" for both axes	Only one measuring encoder can be connected per double-axis device (CDB control section). "P-0-0076, Encoder type 3 (measuring encoder)" may only be unequal "0" for one axis



Only Rexroth service engineers or especially trained users are allowed to replace the control section. The replacement of the entire drive controller is described in the Project Planning Manual for the power section.

See also Functional Description of firmware "Measuring Systems"

C0161 - Attributes **Display:** C0161
 Ident N°: C0161

10.2.51 C0162 Measuring encoder unknown

Allocation	Contained in 02VRS:	«MPB»	«MPH»	«MPD»	
	Contained in 03VRS:	«-»	«-»	«-»	
	Contained in 04VRS:	«-»	«-»	«-»	
	Contained in 05VRS:	«-»	«-»	«-»	
	Contained in 06VRS:	«-»	«-»	«-»	«-»
	Contained in 07VRS:	«-»	«-»	«-»	«-»
	Contained in 08VRS:	«-»	«-»	«-»	«-»
	Supported by supply unit:	«-»			

During the transition check from communication phase 2 to communication phase 3 (C0100) an error with regard to the measuring encoder was detected. The content of "P-0-1020, Kind of encoder 3, encoder memory" is invalid and the measuring encoder therefore is not allowed.

Diagnostic Command Messages

Cause	Remedy
Encoder memory (feedback) is defective	Encoder must be replaced
Kind of motor encoder ("P-0-1020, Kind of encoder 3, encoder memory") is not supported by software	Check content of "P-0-1020, Kind of encoder 3, encoder memory" and contact our service department
Detected kind of encoder does not match parameterized type of encoder ("P-0-0079, Assignment measuring encoder ->optional slot")	Check "P-0-0079, Assignment measuring encoder ->optional slot" and, if necessary, replace control section by correctly configured control section or replace complete drive controller



Only Rexroth service engineers or especially trained users are allowed to replace the control section. The replacement of the entire drive controller is described in the Project Planning Manual for the power section.

C0162 - Attributes Display: C0162
 Ident N°: C0162

10.2.52 C0163 Modulo value for measuring encoder cannot be displayed

Allocation	Contained in 02VRS:	«MPB»	«MPH»	«MPD»
Contained in 03VRS:	«-»	«-»	«-»	
Contained in 04VRS:	«-»	«-»	«-»	
Contained in 05VRS:	«-»	«-»	«-»	
Contained in 06VRS:	«-»	«-»	«-»	«-»
Contained in 07VRS:	«-»	«-»	«-»	«-»
Contained in 08VRS:	«-»	«-»	«-»	«-»
Supported by supply unit:	«-»			

During the transition check from communication phase 2 to communication phase 3 (C0100) an error was detected.

Cause	Remedy
Value parameterized for "P-0-0765, Modulo factor measuring encoder" cannot be displayed internally with gear that was set	Correct content of "S-0-0103, Modulo value" or measuring gear settings ("P-0-0127, Input revolutions of measuring gear" and "P-0-0128, Output revolutions of measuring gear")
"P-0-0327, Encoder resolution of measuring encoder" incorrectly parameterized	Check and, if necessary, correct content of "P-0-0327, Encoder resolution of measuring encoder"

See also Functional Description of firmware "Scaling"

C0163 - Attributes Display: C0163
 Ident N°: C0163

10.2.53 C0164 Incorrect measuring encoder configuration

Allocation	Contained in 02VRS:	«MPB»	«MPH»	«MPD»
Contained in 03VRS:	«-»	«-»	«-»	
Contained in 04VRS:	«-»	«-»	«-»	
Contained in 05VRS:	«-»	«-»	«-»	
Contained in 06VRS:	«-»	«-»	«-»	«-»
Contained in 07VRS:	«-»	«-»	«-»	«-»
Contained in 08VRS:	«-»	«-»	«-»	«-»
Supported by supply unit:	«-»			

During the execution of the command "S-0-0127, C0100 Communication phase 3 transition check" an error with regard to the measuring encoder configuration was detected.

Diagnostic Command Messages

Cause	Remedy
At least one of selected operating modes is synchronization mode (velocity synchronization, phase synchronization or electronic cam shaft) and control encoder of synchronization mode has simultaneously been configured as measuring encoder. This configuration is not useful.	Check and, if necessary, correct parameterization of operating mode parameters ("S-0-0032, Primary mode of operation"; "S-0-0033, Secondary operation mode 1"; "S-0-0034, Secondary operation mode 2";...) if synchronization mode is not required. If synchronization mode is required, deactivate measuring encoder or use additional encoder as measuring encoder.

For removing command errors see "Command Errors"

C0164 - Attributes Display: C0164
 Ident N°: C0164

10.2.54 C0170 Config. IDNs for connection not configurable

Allocation	Contained in 02VRS:	«-»	«-»	«-»	
	Contained in 03VRS:	«-»	«-»	«-»	
	Contained in 04VRS:	«-»	«-»	«-»	
	Contained in 05VRS:	«MPB»	«MPH»	«MPD»	
	Contained in 06VRS:	«MPB»	«MPH»	«MPD»	«MPC»
	Contained in 07VRS:	«MPB»	«MPH»	«MPD»	«MPC»
	Contained in 08VRS:	«MPB»	«MPH»	«MPD»	«MPC»
	Supported by supply unit:	«-»			

Cause	Remedy
When SERCOS III connections had been configured (S-0-1050.x.6, SIII-Connection: Configuration list), an inadmissible IDN was parameterized.	Allowed IDNs for consumer connections : "S-0-0134, Master control word" and all IDNs from "S-0-0188, List of configurable data in the MDT" Allowed IDNs for producer connections : "S-0-0135, Drive status word" and all IDNs from "S-0-0187, List of configurable data in the AT"

C0170 - Attributes Display: C0170
 Ident N°: C0170

10.2.55 C0171 Maximum length for connections exceeded

Allocation	Contained in 02VRS:	«-»	«-»	«-»	
	Contained in 03VRS:	«-»	«-»	«-»	
	Contained in 04VRS:	«-»	«-»	«-»	
	Contained in 05VRS:	«MPB»	«MPH»	«MPD»	
	Contained in 06VRS:	«MPB»	«MPH»	«MPD»	«MPC»
	Contained in 07VRS:	«MPB»	«MPH»	«MPD»	«MPC»
	Contained in 08VRS:	«MPB»	«MPH»	«MPD»	«MPC»
	Supported by supply unit:	«-»			

Cause	Remedy
When SERCOS III connections had been configured, allowed connection length was exceeded; i.e. total length of all configured IDNs in "S-0-1050.x.6, SIII-Connection: Configuration list" exceed value in "S-0-1050.x.4, SIII-Connection: Max. length of connection".	Reduce number of IDNs in "S-0-1050.x.6, SIII-Connection: Configuration list".

C0171 - Attributes Display: C0171
 Ident N°: C0171

10.2.56 C0172 Delay measurement (S-0-1024) not carried out

Allocation	Contained in 02VRS:	«-»	«-»	«-»	
	Contained in 03VRS:	«-»	«-»	«-»	
	Contained in 04VRS:	«-»	«-»	«-»	
	Contained in 05VRS:	«-»	«-»	«-»	
	Contained in 06VRS:	«MPB»	«MPH»	«MPD»	«MPC»
	Contained in 07VRS:	«MPB»	«MPH»	«MPD»	«MPC»
	Contained in 08VRS:	«MPB»	«MPH»	«MPD»	«MPC»
	Supported by supply unit:	«-»			

A check run during the execution of the command "S-0-0127, C0100 Communication phase 3 transition check" showed that there is no correctly executed delay measurement with usable measured values available.

Cause	Remedy
Command "S-0-1024, C5300 SERCOS III: SYNC delay measuring procedure command" was not executed or aborted with error.	Execute command "S-0-1024, C5300 SERCOS III: SYNC delay measuring procedure command" and then start command "S-0-0127, C0100 Communication phase 3 transition check" again.

C0172 - Attributes Display: C0172
 Ident N°: C0172

10.2.57 C0173 Connections (number) not configurable

Allocation	Contained in 02VRS:	«-»	«-»	«-»	
	Contained in 03VRS:	«-»	«-»	«-»	
	Contained in 04VRS:	«-»	«-»	«-»	
	Contained in 05VRS:	«-»	«-»	«-»	
	Contained in 06VRS:	«MPB»	«MPH»	«MPD»	«MPC»
	Contained in 07VRS:	«MPB»	«MPH»	«MPD»	«MPC»
	Contained in 08VRS:	«MPB»	«MPH»	«MPD»	«MPC»
	Supported by supply unit:	«-»			

Cause	Remedy
Parameterized connections in S-0-1050 cannot be realized, because resources of SERCOS III FPGA have been exceeded.	Arrange connections of slave better in telegram (put them one after another). (Can only be corrected by bus master or configurator.)

C0173 - Attributes Display: C0173
 Ident N°: C0173

10.2.58 C0174 Connection configuration not allowed

Allocation	Contained in 02VRS:	«-»	«-»	«-»	
	Contained in 03VRS:	«-»	«-»	«-»	
	Contained in 04VRS:	«-»	«-»	«-»	
	Contained in 05VRS:	«-»	«-»	«-»	
	Contained in 06VRS:	«MPB»	«MPH»	«MPD»	«MPC»
	Contained in 07VRS:	«MPB»	«MPH»	«MPD»	«MPC»
	Contained in 08VRS:	«MPB»	«MPH»	«MPD»	«MPC»
	Supported by supply unit:	«-»			

Cause	Remedy
For a SERCOS III connection, a configuration has been set which is not supported by drive controller/firmware	"S-0-1050.x.1, SIII-Connection: Connection setup" is to be checked in all SERCOS III connections and has to be compared to allowed configurations in Parameter Description

Diagnostic Command Messages

C0174 - Attributes **Display:** C0174
Ident N°: C0174

10.2.59 C0175 Producer cycle time of a connection not correct

Allocation	Contained in 02VRS:	«-»	«-»	«-»
	Contained in 03VRS:	«-»	«-»	«-»
	Contained in 04VRS:	«-»	«-»	«-»
	Contained in 05VRS:	«-»	«-»	«-»
	Contained in 06VRS:	«MPB»	«MPH»	«MPD» «MPC»
	Contained in 07VRS:	«MPB»	«MPH»	«MPD» «MPC»
	Contained in 08VRS:	«MPB»	«MPH»	«MPD» «MPC»
	Supported by supply unit:	«-»		

Cause	Remedy
For a SERCOS IIIconnection, a producer cycle time has been set which is not supported by drive controller/firmware	"S-0-1050.x.10, SIII-Connection: Producer cycle time" is to be checked in all SERCOS IIIconnections and has to be compared to allowed producer cycle times in Parameter Description

C0175 - Attributes **Display:** C0175
Ident N°: C0175

10.2.60 C0199 Functional package selection changed. Restart

Allocation	Contained in 02VRS:	«MPB»	«MPH»	«MPD»
	Contained in 03VRS:	«MPB»	«MPH»	«MPD»
	Contained in 04VRS:	«-»	«-»	«-»
	Contained in 05VRS:	«-»	«-»	«-»
	Contained in 06VRS:	«-»	«-»	«-» «-»
	Contained in 07VRS:	«-»	«-»	«-» «-»
	Contained in 08VRS:	«-»	«-»	«-» «-»
	Supported by supply unit:	«-»		

During the execution of the command "S-0-0127, C0100 Communication phase 3 transition check", the drive detected that the functional package selection was changed in communication phase 2 but the drive was not rebooted.

Cause	Remedy
Parameter "P-0-2003, Selection of functional packages" contains functional package selection not corresponding to active functional package selection (cf. "P-0-2004, Active functional packages")	Switch drive off and on again in order to accept functional package selection of "P-0-2003, Selection of functional packages" in "P-0-2004, Active functional packages"
Incorrect functional package selection in "P-0-2003, Selection of functional packages"	Set value in "P-0-2003, Selection of functional packages" to value in "P-0-2004, Active functional packages"

See also Functional Description of firmware "Enabling of Functional Packages"

For removing command errors see "Command Errors"

C0199 - Attributes **Display:** C0199
Ident N°: C0199

10.2.61 C0201 Invalid parameters (->S-0-0423)

Allocation	Contained in 02VRS:	«MPB»	«MPH»	«MPD»	
	Contained in 03VRS:	«MPB»	«MPH»	«MPD»	
	Contained in 04VRS:	«MPB»	«MPH»	«MPD»	
	Contained in 05VRS:	«MPB»	«MPH»	«MPD»	
	Contained in 06VRS:	«MPB»	«MPH»	«MPD»	«MPC»
	Contained in 07VRS:	«MPB»	«MPH»	«MPD»	«MPC»
	Contained in 08VRS:	«MPB»	«MPH»	«MPD»	«MPC»
	Supported by supply unit:	«HMV»			



In firmware versions 02VRS and 03VRS, the name of the command error is "C0201 Invalid parameters (->S-0-0022)".

02VRS / 03VRS While command "S-0-0128, C5200 Communication phase 4 transition check" is executed, internal variables are initialized and the available parameters are checked (e.g., for validity). An error was detected during execution of the command.

Cause	Remedy
Data block elements required in communication phase 4 are missing or invalid	Write allowed operating data to parameters affected. (Affected parameters can be taken from list "S-0-0022, IDN-list of invalid operation data for CP3")

As of 04VRS While command "S-0-0422, C0200 Exit parameterization level procedure command" is executed, internal variables are initialized and the available parameters are checked (e.g., for validity). An error was detected during execution of the command.

Cause	Remedy
Data required in operating mode is missing or invalid	Write allowed operating data to parameters affected. (Respective parameters can be taken from list "S-0-0423, IDN-list of invalid data for parameterization levels")

For removing command errors see "Command Errors"

C0201 - Attributes **Display:** C0201
 Ident N°: C0201

10.2.62 C0202 Parameter limit error (->S-0-0423)

Allocation	Contained in 02VRS:	«MPB»	«MPH»	«MPD»	
	Contained in 03VRS:	«MPB»	«MPH»	«MPD»	
	Contained in 04VRS:	«MPB»	«MPH»	«MPD»	
	Contained in 05VRS:	«MPB»	«MPH»	«MPD»	
	Contained in 06VRS:	«MPB»	«MPH»	«MPD»	«MPC»
	Contained in 07VRS:	«MPB»	«MPH»	«MPD»	«MPC»
	Contained in 08VRS:	«MPB»	«MPH»	«MPD»	«MPC»
	Supported by supply unit:	«HMV»			



In the firmware versions 02VRS and 03VRS, the name of the command error is "C0202 Parameter limit error (->S-0-0022)".

02VRS / 03VRS While the command "S-0-0128, C0200 Communication phase 4 transition check" is executed, the limit values (minimum/maximum value) are checked for some parameters. An error was detected during the execution of the command.

Diagnostic Command Messages

Cause	Remedy
Parameter values required in communication phase 4 are outside of their allowed range of values (minimum or maximum value)	Write allowed values to parameters (cf. min./max. value). (Respective parameters can be taken from list "S-0-0022, IDN list of invalid operating data for communication phase 3")

As of 04VRS While the command "S-0-0422, C0200 Exit parameterization level procedure command" is executed, the limit values (minimum/maximum value) are checked for some parameters. An error was detected during the execution of the command.

Cause	Remedy
Parameter values required in operating mode are outside of their allowed range of values (minimum or maximum value)	Write allowed values to parameters (cf. min./max. value). (Respective parameters can be taken from list "S-0-0423, IDN-list of invalid op. data for parameterization level")

For removing command errors see "Command Errors"

C0202 - Attributes **Display:** C0202
 Ident N°: C0202

10.2.63 C0203 Parameter conversion error (->S-0-0423)

Allocation	Contained in 02VRS:	«MPB»	«MPH»	«MPD»	
	Contained in 03VRS:	«MPB»	«MPH»	«MPD»	
	Contained in 04VRS:	«MPB»	«MPH»	«MPD»	
	Contained in 05VRS:	«MPB»	«MPH»	«MPD»	
	Contained in 06VRS:	«MPB»	«MPH»	«MPD»	«MPC»
	Contained in 07VRS:	«MPB»	«MPH»	«MPD»	«MPC»
	Contained in 08VRS:	«MPB»	«MPH»	«MPD»	«MPC»
	Supported by supply unit:	«HMV»			



In the firmware versions 02VRS and 03VRS, the name of the command error is "C0203 Parameter calculation error (->S-0-0022)".

02VRS / 03VRS While the command "S-0-0128, C0200 Communication phase 4 transition check" is executed, the internal parameter formats are checked in order to ensure the internal processing. An error was detected during the execution of the command.

Cause	Remedy
Parameter values required in communication phase 4 cannot be processed	Write allowed values to parameters. (Respective parameters can be taken from list "S-0-0022, IDN list of invalid operating data for communication phase 3")

As of 04VRS While the command "S-0-0422, C0200 Exit parameterization level procedure command" is executed, the internal parameter formats are checked in order to ensure the internal processing. An error was detected during the execution of the command.

Cause	Remedy
Parameter values required in operating mode cannot be processed	Write allowed values to parameters. (Respective parameters can be taken from list "S-0-0423, IDN-list of invalid op. data for parameterization level")

For removing command errors see "Command Errors"

C0203 - Attributes **Display:** C0203
 Ident N°: C0203

10.2.64 C0210 Feedback 2 required (->S-0-0423)

Allocation	Contained in 02VRS:	«-»	«-»	«-»	
	Contained in 03VRS:	«-»	«-»	«-»	
	Contained in 04VRS:	«MPB»	«MPH»	«MPD»	
	Contained in 05VRS:	«MPB»	«MPH»	«MPD»	
	Contained in 06VRS:	«MPB»	«MPH»	«MPD»	«MPC»
	Contained in 07VRS:	«MPB»	«MPH»	«MPD»	«MPC»
	Contained in 08VRS:	«MPB»	«MPH»	«MPD»	«MPC»
	Supported by supply unit:	«-»			

Incorrect parameter setting was detected during the execution of command "S-0-0422, C0200 Exit parameterization level procedure command".



"S-0-0423, IDN-list of invalid op. data for parameterization level" contains the data which were detected to be invalid during the execution of command "S-0-0422, C0200 Exit parameterization level procedure command".

Cause	Remedy
Bit for measuring wheel mode has been set in "P-0-0185, Control word of encoder 2 (optional encoder)". Measuring wheel mode requires second encoder which has not been parameterized	Parameterize encoder 2 in "P-0-0075, Encoder type 2 (optional encoder)" - or - Deselect function "measuring wheel mode" in "P-0-0185, Control word of encoder 2 (optional encoder)"
Bit for redundant motor encoder has been set in "P-0-0185, Control word of encoder 2 (optional encoder)". Second encoder, however, has not been parameterized	Parameterize encoder 2 in "P-0-0075, Encoder type 2 (optional encoder)" - or - Deselect redundant motor encoder in "P-0-0185, Control word of encoder 2 (optional encoder)"

C0210 - Attributes **Display:** C0210
 Ident N°: C0210

10.2.65 C0212 Invalid control section data (->S-0-0423)

Allocation	Contained in 02VRS:	«MPB»	«MPH»	«MPD»	
	Contained in 03VRS:	«MPB»	«MPH»	«MPD»	
	Contained in 04VRS:	«MPB»	«MPH»	«MPD»	
	Contained in 05VRS:	«MPB»	«MPH»	«MPD»	
	Contained in 06VRS:	«MPB»	«MPH»	«MPD»	«MPC»
	Contained in 07VRS:	«MPB»	«MPH»	«MPD»	«MPC»
	Contained in 08VRS:	«MPB»	«MPH»	«MPD»	«MPC»
	Supported by supply unit:	«HMV»			



In the firmware versions 02VRS and 03VRS, the name of the command error is "C0212 Invalid control section data (->S-0-0022)".

02VRS / 03VRS:

For HMS, HMD, HCS

During the execution of the command "S-0-0128, C0200 Communication phase 4 transition check" an error during the initialization of the control section data was detected. The respective parameters are entered in the list "S-0-0022, IDN list of invalid operating data for communication phase 3".

Diagnostic Command Messages

For HMV During the initialization of the device data an error was detected.

Cause	Remedy
Reading error from I2C-Prom due to hardware defect	If possible, replace hardware; otherwise contact our service department

As of 04VRS:

For HMS, HMD, HCS During the execution of the command "S-0-0422, C0200 Exit parameterization level procedure command" an error was detected during the initialization of the amplifier data. The respective parameters are entered in the list "S-0-0423, IDN-list of invalid op. data for parameterization level".

For HMV During the initialization of the device data an error was detected.

Cause	Remedy
Reading error from I2C-Prom due to hardware defect	If possible, replace hardware; otherwise contact our service department

For removing command errors see "Command Errors"

C0212 - Attributes **Display:** C0212
 Ident N°: C0212

10.2.66 C0218 Double signal selection master axis format converter

Allocation	Contained in 02VRS:	«-»	«-»	«-»	
	Contained in 03VRS:	«-»	«-»	«-»	
	Contained in 04VRS:	«-»	«-»	«MPD»	
	Contained in 05VRS:	«-»	«-»	«MPD»	
	Contained in 06VRS:	«-»	«-»	«MPD»	«-»
	Contained in 07VRS:	«-»	«-»	«MPD»	«-»
	Contained in 08VRS:	«-»	«-»	«MPD»	«-»
	Supported by supply unit:	«-»			

During the execution of the command "S-0-0422, C0200 Exit parameterization level procedure command" an error occurred.

Cause	Remedy
In the case of a double-axis device, a parameter was selected in both axes in parameter "P-0-0916, Master axis format converter signal selection" the value of which is to be converted to master axis format; however, there is only one master axis format converter available for a double axis device	Set parameter "P-0-0916, Master axis format converter signal selection" of one axis of double-axis device to "S-0-0000"

C0218 - Attributes **Display:** C0218
 Ident N°: C0218

10.2.67 C0219 Max. travel range too large

Allocation	Contained in 02VRS:	«-»	«-»	«-»	
	Contained in 03VRS:	«MPB»	«MPH»	«MPD»	
	Contained in 04VRS:	«MPB»	«MPH»	«MPD»	
	Contained in 05VRS:	«MPB»	«MPH»	«MPD»	
	Contained in 06VRS:	«MPB»	«MPH»	«MPD»	«MPC»
	Contained in 07VRS:	«MPB»	«MPH»	«MPD»	«MPC»
	Contained in 08VRS:	«MPB»	«MPH»	«MPD»	«MPC»
	Supported by supply unit:	«-»			

While the command "C0200" is executed an error with regard to the scaling of the drive was detected.

Diagnostic Command Messages

10.2.69 C0221 Initialization velocity encoder 1 too high

Allocation	Contained in 02VRS:	«MPB»	«MPH»	«MPD»	
	Contained in 03VRS:	«MPB»	«MPH»	«MPD»	
	Contained in 04VRS:	«MPB»	«MPH»	«MPD»	
	Contained in 05VRS:	«MPB»	«MPH»	«MPD»	
	Contained in 06VRS:	«MPB»	«MPH»	«MPD»	«MPC»
	Contained in 07VRS:	«MPB»	«MPH»	«MPD»	«MPC»
	Contained in 08VRS:	«MPB»	«MPH»	«MPD»	«MPC»
	Supported by supply unit:	«-»			

During the execution of the command C0200, an error in the initialization velocity of encoder 1 (motor encoder) was detected.

Cause	Remedy
Velocity for initialization of encoder 1 was too high	Reduce velocity during encoder initialization [comply with initialization velocity (encoder-related); rotary: <30 rpm, linear: 30 mm/min]

For removing command errors see "Command Errors"

C0221 - Attributes	Display:	C0221
	Ident N°:	C0221

10.2.70 C0223 Invalid settings for controller cycle times

Allocation	Contained in 02VRS:	«-»	«-»	«-»	
	Contained in 03VRS:	«-»	«-»	«-»	
	Contained in 04VRS:	«MPB»	«MPH»	«MPD»	
	Contained in 05VRS:	«MPB»	«MPH»	«MPD»	
	Contained in 06VRS:	«MPB»	«MPH»	«MPD»	«MPC»
	Contained in 07VRS:	«MPB»	«MPH»	«MPD»	«MPC»
	Contained in 08VRS:	«MPB»	«MPH»	«MPD»	«MPC»
	Supported by supply unit:	«-»			

During the execution of the command "C0200" an error in the parameterization of controller cycle times or PWM switching frequencies was detected.

For cause and remedy see "C0132 Invalid settings for controller cycle times".

C0223 - Attributes	Display:	C0223
	Ident N°:	C0223

10.2.71 C0224 Error when initializing position of encoder 2

Allocation	Contained in 02VRS:	«MPB»	«MPH»	«MPD»	
	Contained in 03VRS:	«MPB»	«MPH»	«MPD»	
	Contained in 04VRS:	«MPB»	«MPH»	«MPD»	
	Contained in 05VRS:	«MPB»	«MPH»	«MPD»	
	Contained in 06VRS:	«MPB»	«MPH»	«MPD»	«MPC»
	Contained in 07VRS:	«MPB»	«MPH»	«MPD»	«MPC»
	Contained in 08VRS:	«MPB»	«MPH»	«MPD»	«MPC»
	Supported by supply unit:	«-»			

While command "C0200" is executed, the following checks are carried out for initializing encoder 2 (optional encoder):

- Offset between high-resolution and low-resolution track
- Communication with encoder
- Generation of position of an initialization track
- Reading of analog signals of an initialization track

If the optional encoder is an HSF encoder, the following checks are additionally carried out:

- Access to angle correction data

Diagnostic Command Messages

- Pointer length of analog signals of an initialization track
- If one of the above checks fails, the command error "C0224" is generated.

Cause	Remedy
Encoder cable defective	Check and, if necessary, replace encoder cable
Encoder defective or error in micro controller of measuring system	Replace encoder
Measuring system interface defective	Have measuring system interface replaced by service department
Absolute position in relation to incremental track shifted	Absolute position in relation to incremental track was shifted deliberately (as of MPx07V12, MPx06V14, MPx08): Deactivate offset monitoring (see S-0-0115) Absolute position in relation to incremental track was shifted by a defect : Check other causes mentioned

For removing command errors see "Command Errors"

C0224 - Attributes **Display:** C0224
 Ident N°: C0224

10.2.72 C0225 Initialization velocity encoder 2 too high

Allocation	Contained in 02VRS:	«MPB»	«MPH»	«MPD»	
	Contained in 03VRS:	«MPB»	«MPH»	«MPD»	
	Contained in 04VRS:	«MPB»	«MPH»	«MPD»	
	Contained in 05VRS:	«MPB»	«MPH»	«MPD»	
	Contained in 06VRS:	«MPB»	«MPH»	«MPD»	«MPC»
	Contained in 07VRS:	«MPB»	«MPH»	«MPD»	«MPC»
	Contained in 08VRS:	«MPB»	«MPH»	«MPD»	«MPC»
	Supported by supply unit:	«-»			

During the execution of the command C0200, an error in the initialization velocity of encoder 2 (optional encoder) was detected.

Cause	Remedy
Velocity for initialization of encoder 2 was too high	Reduce velocity during encoder initialization [comply with initialization velocity (encoder-related); rotary: <30 rpm, linear: 30 mm/min]

For removing command errors see "Command Errors"

C0225 - Attributes **Display:** C0225
 Ident N°: C0225

10.2.73 C0227 Error when initializing position of measuring encoder

Allocation	Contained in 02VRS:	«MPB»	«MPH»	«MPD»	
	Contained in 03VRS:	«MPB»	«MPH»	«MPD»	
	Contained in 04VRS:	«MPB»	«MPH»	«MPD»	
	Contained in 05VRS:	«MPB»	«MPH»	«MPD»	
	Contained in 06VRS:	«MPB»	«MPH»	«MPD»	«MPC»
	Contained in 07VRS:	«MPB»	«MPH»	«MPD»	«MPC»
	Contained in 08VRS:	«MPB»	«MPH»	«MPD»	«MPC»
	Supported by supply unit:	«-»			

While command "C0200" is executed, the following checks are carried out for initializing the measuring encoder:

- Offset between high-resolution and low-resolution track
- Communication with encoder

Diagnostic Command Messages

- Generation of position of an initialization track
- Reading of analog signals of an initialization track

If the measuring encoder is an HSF encoder, the following checks are additionally carried out:

- Access to angle correction data
- Pointer length of analog signals of an initialization track

If one of the above checks fails, the command error "C0227" is generated.

Cause	Remedy
Encoder cable defective	Check and, if necessary, replace encoder cable
Interference caused by incorrect shielding	Check and, if necessary, correct cable shielding
Encoder defective or error in micro controller of measuring system	Replace encoder
Measuring system interface defective	Have measuring system interface replaced by service department
Absolute position in relation to incremental track shifted	Absolute position in relation to incremental track was shifted deliberately (as of MPx07V12, MPx06V14, MPx08): Deactivate offset monitoring (see P-0-0328) Absolute position in relation to incremental track was shifted by a defect : Check other causes mentioned

For removing command errors see "Command Errors"

C0227 - Attributes Display: C0227
 Ident N°: C0227

10.2.74 C0228 Initialization velocity measuring encoder too high

Allocation	Contained in 02VRS:	«MPB»	«MPH»	«MPD»	
	Contained in 03VRS:	«MPB»	«MPH»	«MPD»	
	Contained in 04VRS:	«MPB»	«MPH»	«MPD»	
	Contained in 05VRS:	«MPB»	«MPH»	«MPD»	
	Contained in 06VRS:	«MPB»	«MPH»	«MPD»	«MPC»
	Contained in 07VRS:	«MPB»	«MPH»	«MPD»	«MPC»
	Contained in 08VRS:	«MPB»	«MPH»	«MPD»	«MPC»
	Supported by supply unit:	«-»			

During the execution of the command C0200, an error in the initialization velocity of the measuring encoder was detected.

Cause	Remedy
Velocity for initialization of measuring encoder was too high	Reduce velocity during encoder initialization [comply with initialization velocity (encoder-related); rotary : <30 rpm, linear : 30 mm/min]

For removing command errors see "Command Errors"

C0228 - Attributes Display: C0228
 Ident N°: C0228

10.2.75 C0229 Field bus: IDN for cycl. command val. not configurable

Allocation	Contained in 02VRS:	«-»	«-»	«-»	
	Contained in 03VRS:	«-»	«-»	«-»	
	Contained in 04VRS:	«MPB»	«MPH»	«MPD»	
	Contained in 05VRS:	«MPB»	«MPH»	«MPD»	
	Contained in 06VRS:	«MPB»	«MPH»	«MPD»	«MPC»
	Contained in 07VRS:	«MPB»	«MPH»	«MPD»	«MPC»
	Contained in 08VRS:	«MPB»	«MPH»	«MPD»	«MPC»
	Supported by supply unit:	«-»			

During the execution of the command "C0200" an error with regard to the telegram configuration of master communication was detected.

Cause	Remedy
In operating data of "P-0-4081, Field bus: config. list of cyclic command value data ch." there is an IDN that is not contained in "S-0-0188, List of configurable data in the MDT"	In "P-0-4081, Field bus: config. list of cyclic command value data ch." enter allowed IDN (cf. "S-0-0188, List of configurable data in the MDT")

For removing command errors see "Command Errors"

C0229 - Attributes	Display:	C0229
	Ident N°:	C0229

10.2.76 C0230 Field bus: Max. length for cycl. command val. exceeded

Allocation	Contained in 02VRS:	«-»	«-»	«-»	
	Contained in 03VRS:	«-»	«-»	«-»	
	Contained in 04VRS:	«MPB»	«MPH»	«MPD»	
	Contained in 05VRS:	«MPB»	«MPH»	«MPD»	
	Contained in 06VRS:	«MPB»	«MPH»	«MPD»	«MPC»
	Contained in 07VRS:	«MPB»	«MPH»	«MPD»	«MPC»
	Contained in 08VRS:	«MPB»	«MPH»	«MPD»	«MPC»
	Supported by supply unit:	«-»			

While command "C0200" is executed, an error with regard to the axis-specific telegram configuration of a local axis of master communication was detected.

Cause	Remedy
Sum of data widths of all IDNs entered in "P-0-4081, Field bus: Config. list of cyclic command value data ch." exceeds maximum value	Reduce number of IDNs entered in "P-0-4081, Field bus: Config. list of cyclic command value data ch."

C0230 - Attributes	Display:	C0230
	Ident N°:	C0230

10.2.77 C0231 Field bus: IDN for cycl. actual val. not configurable

Allocation	Contained in 02VRS:	«-»	«-»	«-»	
	Contained in 03VRS:	«-»	«-»	«-»	
	Contained in 04VRS:	«MPB»	«MPH»	«MPD»	
	Contained in 05VRS:	«MPB»	«MPH»	«MPD»	
	Contained in 06VRS:	«MPB»	«MPH»	«MPD»	«MPC»
	Contained in 07VRS:	«MPB»	«MPH»	«MPD»	«MPC»
	Contained in 08VRS:	«MPB»	«MPH»	«MPD»	«MPC»
	Supported by supply unit:	«-»			

During the execution of the command "C0200" an error with regard to the telegram configuration of master communication was detected.

Diagnostic Command Messages

Cause	Remedy
In operating data of "P-0-4080, Field bus: config. list of cyclic command value data ch." there is an IDN that is not contained in "S-0-0187, List of configurable data in the AT"	In "P-0-4080, Field bus: config. list of cyclic command value data ch." enter allowed IDNs (cf. "S-0-0187, List of configurable data in the AT")



List parameters are only allowed in the multiplex channel.

For removing command errors see "Command Errors"

C0231 - Attributes **Display:** C0231
 Ident N°: C0231

10.2.78 C0232 Field bus: Length for cycl. actual values exceeded

Allocation	Contained in 02VRS:	«-»	«-»	«-»	
	Contained in 03VRS:	«-»	«-»	«-»	
	Contained in 04VRS:	«MPB»	«MPH»	«MPD»	
	Contained in 05VRS:	«MPB»	«MPH»	«MPD»	
	Contained in 06VRS:	«MPB»	«MPH»	«MPD»	«MPC»
	Contained in 07VRS:	«MPB»	«MPH»	«MPD»	«MPC»
	Contained in 08VRS:	«MPB»	«MPH»	«MPD»	«MPC»
	Supported by supply unit:	«-»			

While command "C0200 Exit parameterization level procedure command" is executed, an error with regard to the axis-specific telegram configuration of a local axis of master communication was detected.

Cause	Remedy
Sum of data widths of all IDNs entered in "P-0-4080, Field bus: Config. list of cyclic command actual data ch." exceeds maximum value	Reduce number of IDNs entered in "P-0-4080, Field bus: Config. list of cyclic actual value data ch."

C0232 - Attributes **Display:** C0232
 Ident N°: C0232

10.2.79 C0233 Field bus: Tcyc (P-0-4076) incorrect

Allocation	Contained in 02VRS:	«-»	«-»	«-»	
	Contained in 03VRS:	«-»	«-»	«-»	
	Contained in 04VRS:	«MPB»	«MPH»	«MPD»	
	Contained in 05VRS:	«MPB»	«MPH»	«MPD»	
	Contained in 06VRS:	«MPB»	«MPH»	«MPD»	«MPC»
	Contained in 07VRS:	«MPB»	«MPH»	«MPD»	«MPC»
	Contained in 08VRS:	«MPB»	«MPH»	«MPD»	«MPC»
	Supported by supply unit:	«-»			

Cause	Remedy
While command C0200 was executed, error in parameterization of P-0-4076 was detected.	Observe allowed input values (minimum/maximum values) of "P-0-4076, Field bus: Field bus: Process data - updating clock"; step size of allowed input values: 1 ms

For removing command errors see "Command Errors"

C0233 - Attributes **Display:** C0233
 Ident N°: C0233

10.2.80 C0234 Field bus: P-0-4077 missing for cycl. command values

Allocation	Contained in 02VRS:	«-»	«-»	«-»	
	Contained in 03VRS:	«-»	«-»	«-»	
	Contained in 04VRS:	«MPB»	«MPH»	«MPD»	
	Contained in 05VRS:	«MPB»	«MPH»	«MPD»	
	Contained in 06VRS:	«MPB»	«MPH»	«MPD»	«MPC»
	Contained in 07VRS:	«MPB»	«MPH»	«MPD»	«MPC»
	Contained in 08VRS:	«MPB»	«MPH»	«MPD»	«MPC»
	Supported by supply unit:	«-»			

During the execution of the command "C0200" an error with regard to the telegram configuration of master communication was detected.

Cause	Remedy
Operating data of "P-0-4081, Field bus: config. list of cyclic command value data ch." contains neither "P-0-4077, Field bus: control word" nor "P-0-4068, Field bus: control word IO". At least one control word has to be contained	According to profile type configure one of both control words in "P-0-4081, Field bus: config. list of cyclic command value data ch."

For removing command errors see "Command Errors"

C0234 - Attributes
 Display: C0234
 Ident N°: C0234

10.2.81 C0238 Order of cyclic command value configuration incorrect

Allocation	Contained in 02VRS:	«-»	«-»	«-»	
	Contained in 03VRS:	«-»	«-»	«-»	
	Contained in 04VRS:	«MPB»	«MPH»	«MPD»	
	Contained in 05VRS:	«MPB»	«MPH»	«MPD»	
	Contained in 06VRS:	«MPB»	«MPH»	«MPD»	«MPC»
	Contained in 07VRS:	«MPB»	«MPH»	«MPD»	«MPC»
	Contained in 08VRS:	«MPB»	«MPH»	«MPD»	«MPC»
	Supported by supply unit:	«-»			

The cyclic command value data in the drive is processed chronologically in the order in which the configured IDNs have been entered in the list of cyclic command values. The following parameters are available for using multiplex mode in the cyclic command value telegram:

- S-0-0360, Data container A: command value 1,
- S-0-0362, Data container A: list index command values and
- S-0-0368, Data container A: Addressing

If more of these parameters than one are configured in the cyclic command value telegram, their correct order is checked in command "S-0-0128, C5200 Communication phase 4 transition check" (02VRS / 03VRS) or "S-0-0422, C0200 Exit parameterization level procedure command" (as of 04VRS).

Cause	Remedy
Incorrect order of relevant parameters in cyclic command value telegram	Observe correct order of parameters in cyclic command value telegram: Parameters S-0-0362, S-0-0366 and S-0-0368 must precede parameters S-0-0360 and S-0-0450 to S-0-0456 in cyclic command value telegram

See also Functional Description of firmware "Multiplex Channel"

C0238 - Attributes
 Display: C0238
 Ident N°: C0238

Diagnostic Command Messages

10.2.82 C0239 IDN for command value data container not allowed

Allocation	Contained in 02VRS:	«-»	«-»	«-»	
	Contained in 03VRS:	«-»	«-»	«-»	
	Contained in 04VRS:	«MPB»	«MPH»	«MPD»	
	Contained in 05VRS:	«MPB»	«MPH»	«MPD»	
	Contained in 06VRS:	«MPB»	«MPH»	«MPD»	«MPC»
	Contained in 07VRS:	«MPB»	«MPH»	«MPD»	«MPC»
	Contained in 08VRS:	«MPB»	«MPH»	«MPD»	«MPC»
	Supported by supply unit:	«-»			

During the execution of command "S-0-0128, C0200 Communication phase 4 transition check" (02VRS / 03VRS) or "S-0-0422, C0200 Exit parameterization level procedure command" (as of 04VRS), an error with regard to the command value configuration list was detected.

Cause	Remedy
A command value configuration list (S-0-0370 and S-0-0490 to S-0-0496) contains one or several IDNs that aren't existing or not contained in "S-0-0188, List of configurable data in the MDT"	Check parameters "S-0-0370, Data container A: configuration list command value-1" and "S-0-0490, Data container A: configuration list command value 2" to "S-0-0496, Data container A: configuration list command value 8" for incorrect IDNs and correct them

For removing command errors see "Command Errors"

See also Functional Description of firmware "Multiplex Channel"

C0239 - Attributes	Display:	C0239
	Ident N°:	C0239

10.2.83 C0240 IDN for actual value data container not allowed

Allocation	Contained in 02VRS:	«-»	«-»	«-»	
	Contained in 03VRS:	«-»	«-»	«-»	
	Contained in 04VRS:	«MPB»	«MPH»	«MPD»	
	Contained in 05VRS:	«MPB»	«MPH»	«MPD»	
	Contained in 06VRS:	«MPB»	«MPH»	«MPD»	«MPC»
	Contained in 07VRS:	«MPB»	«MPH»	«MPD»	«MPC»
	Contained in 08VRS:	«MPB»	«MPH»	«MPD»	«MPC»
	Supported by supply unit:	«-»			

During the execution of command "S-0-0128, C0200 Communication phase 4 transition check" (02VRS / 03VRS) or "S-0-0422, C0200 Exit parameterization level procedure command" (as of 04VRS), an error with regard to the actual value configuration list was detected.

Cause	Remedy
An actual value configuration list (S-0-0371 and S-0-0500 to S-0-0506) contains one or several IDNs that aren't existing or not contained in "S-0-0187, List of configurable data in the AT"	Check parameters "S-0-0371, Data container A: configuration list feedback value-1" and "S-0-0500, Data container A: configuration list feedback value 2" to "S-0-0506, Data container A: configuration list feedback value 8" for incorrect IDNs and correct them

For removing command errors see "Command Errors"

See also Functional Description of firmware "Multiplex Channel"

C0240 - Attributes	Display:	C0240
	Ident N°:	C0240

10.2.84 C0241 Incorrect parameterization of motion task

Allocation	Contained in 02VRS:	«-»	«-»	«-»	
	Contained in 03VRS:	«-»	«-»	«-»	
	Contained in 04VRS:	«-»	«-»	«-»	
	Contained in 05VRS:	«MPB»	«MPH»	«-»	
	Contained in 06VRS:	«MPB»	«MPH»	«-»	«MPC»
	Contained in 07VRS:	«MPB»	«MPH»	«-»	«MPC»
	Contained in 08VRS:	«MPB»	«MPH»	«-»	«MPC»
	Supported by supply unit:	«-»			

A motion task is of the type "externally event-controlled".

Two of these motion tasks are available as of firmware version MP05VRS.

- Motion task which is synchronous to master communication (via the system event **FKM_SYNCHRONIZED_TASK**)
- Motion task which is synchronous to CCD group (via the system event **CCD_SYNCHRONIZED_TASK**)

When switching from parameter mode to operating mode takes place, checks are run for a loaded boot project, with a motion task synchronous to master communication or CCD group, to find out whether the motion task can be operated with the settings made; an error was detected during this check. (See also Application Manual "Rexroth IndraMotion MLD", chapter "Basic Functions of Rexroth IndraMotion MLD", "Task System".)

Cause	Remedy
A motion task which is synchronous to master communication cannot be operated with NC cycle time (S-0-0001 or S-0-1001 for master communication SERCOS III) which was set	Advanced and Basic performance: Minimum allowed NC cycle time is 1000µs. Other values in steps of 1000µs are allowed. Economy performance: Minimum allowed NC cycle time is 2000µs. Other values in steps of 2000µs are allowed.
A motion task which is synchronous to CCD group is not operated in MLD-M system mode	Activate MLD-M system mode - or - Change your PLC project for MLD in such a way that no CCD-synchronous motion task is configured

For removing command errors see "Command Errors"

C0241 - Attributes **Display:** C0241
 Ident N°: C0241

10.2.85 C0242 Multiple configuration of a parameter (->S-0-0423)

Allocation	Contained in 02VRS:	«MPB»	«MPH»	«MPD»	
	Contained in 03VRS:	«MPB»	«MPH»	«MPD»	
	Contained in 04VRS:	«MPB»	«MPH»	«MPD»	
	Contained in 05VRS:	«MPB»	«MPH»	«MPD»	
	Contained in 06VRS:	«MPB»	«MPH»	«MPD»	«MPC»
	Contained in 07VRS:	«MPB»	«MPH»	«MPD»	«MPC»
	Contained in 08VRS:	«MPB»	«MPH»	«MPD»	«MPC»
	Supported by supply unit:	«-»			



In the firmware versions 02VRS and 03VRS, the name of the command error is "C0242 Multiple configuration of a parameter (->S-0-0022)".

02VRS / 03VRS During the execution of the command "S-0-0128, C0200 Communication phase 4 transition check" an error was detected.

Diagnostic Command Messages

Cause	Remedy
For a double-axis device, a device-specific function has been activated in both axes (e.g. position switch activated in both axes or encoder emulation activated in both axes)	Read IDNs entered in "S-0-0022, IDN list of invalid operating data for communication phase 3" to find out function activated in both axes. Then deactivate function in one of both axes
For cyclic parameter write, a parameter was simultaneously configured in different interfaces. It is impossible, however, to simultaneously write data to same parameter from different interfaces. Note: "Interfaces" means as well analog and digital inputs as complete bus systems.	Read IDNs entered in "S-0-0022, IDN list of invalid operating data for communication phase 3" to detect and remove multiple configuration.



Each multiple configuration/each conflict is listed in parameter "S-0-0022, IDN list of invalid operating data for communication phase 3" and displayed in the following form:

- The 1st entry contains the IDN of the parameter that was configured in a multiple way.
- The subsequent entries contain the IDNs of the parameters in which the multiple-configuration parameter was configured for cyclic parameter write.
- Up to 5 entries are displayed.
- In the IDN list, each conflict is concluded by the IDN S-0-0000. If several conflicts occur at the same time, they are displayed one after the other in "S-0-0022, IDN list of invalid operating data for communication phase 3", being separated by the IDN **S-0-0000**.

For each conflict, the configurations of the involved interfaces have to be modified in such a way that only one interface writes data to a parameter.

As of 04VRS During the execution of the command "S-0-0422, C0200 Exit parameterization level procedure command" an error was detected.

Cause	Remedy
For a double-axis device, a device-specific function has been activated in both axes (e.g. position switch activated in both axes or encoder emulation activated in both axes)	Read IDNs entered in "S-0-0423, IDN-list of invalid op. data for parameterization level" to find out function activated in both axes. Then deactivate function in one of both axes
For cyclic parameter write, a parameter was simultaneously configured in different interfaces. It is impossible, however, to simultaneously write data to same parameter from different interfaces. Note: "Interfaces" means as well analog and digital inputs as complete bus systems.	Read IDNs entered in "S-0-0423, IDN-list of invalid op. data for parameterization level" to detect and remove multiple configuration.

Diagnostic Command Messages

Cause	Remedy
Holding brake is not controlled	Activate holding brake control in parameter "P-0-0525, Holding brake control word"
"P-0-0540, Torque of holding brake" is too low	Parameterize "P-0-0540, Torque of holding brake" correctly by means of data sheet of brake or motor. Note: This value is automatically set with Rexroth motors equipped with feedback data storage.
"P-0-0547, Nominal load of holding system" is too high	Check parameterized value in "P-0-0547, Nominal load of holding system" with regard to "P-0-0540, Torque of motor holding brake" [observe the scaling type for torque/force data (S-0-0086)]. Up to MPx-07 Force/torque scaling: $P-0-0540 > 1,3 \times P-0-0547$ Percentage scaling: $P-0-0540 > \frac{1,3 \times P-0-0547[\%]}{100\%} \times S-0-0111 \times P-0-0051 \times f_k$ <hr/> As of MPx08 Scaled force/moment: $P-0-0540 > P-0-0553 \times P-0-0547$ Percentage scaling: $P-0-0540 > \frac{P-0-0553 \times P-0-0547[\%]}{100\%} \times S-0-0111 \times P-0-0051 \times f_k$ Legend: <ul style="list-style-type: none">• P-0-0051, Torque/force constant• P-0-0540, Torque of holding brake• P-0-0547, Nominal load of holding system• P-0-0553, test moment factor for brake check• S-0-0111, Motor current at standstill• f_k: Cooling factor, derived from "P-0-0640, Cooling type"

For removing command errors see "Command Errors"

C0243 - AttributesDisplay: C0243
Ident N°: C0243**10.2.87 C0244 Act. modulo value cycle greater than max. travel range**

Allocation	Contained in 02VRS:	«MPB»	«MPH»	«MPD»	
	Contained in 03VRS:	«MPB»	«MPH»	«MPD»	
	Contained in 04VRS:	«MPB»	«MPH»	«MPD»	
	Contained in 05VRS:	«MPB»	«MPH»	«MPD»	
	Contained in 06VRS:	«MPB»	«MPH»	«MPD»	«MPC»
	Contained in 07VRS:	«MPB»	«MPH»	«MPD»	«MPC»
	Contained in 08VRS:	«MPB»	«MPH»	«MPD»	«MPC»
	Supported by supply unit:	«-»			

During the execution of the command "C0200" an error was detected.

Diagnostic Command Messages

Cause	Remedy
Calculated modulo value for actual value cycle is greater than value parameterized in "S-0-0278, Maximum travel range"	Check parameterization of "S-0-0278, Maximum travel range" and if necessary adjust it to modulo value for actual value cycle – or – Check parameterization of modulo value for actual value cycle and adjust it to "S-0-0278, Maximum travel range"

For removing command errors see "Command Errors"

C0244 - Attributes Display: C0244
 Ident N°: C0244

10.2.88 C0245 Operation mode configuration (->S-0-0423) not allowed

Allocation	Contained in 02VRS:	«MPB»	«MPH»	«MPD»	
	Contained in 03VRS:	«MPB»	«MPH»	«MPD»	
	Contained in 04VRS:	«MPB»	«MPH»	«MPD»	
	Contained in 05VRS:	«MPB»	«MPH»	«MPD»	
	Contained in 06VRS:	«MPB»	«MPH»	«MPD»	«MPC»
	Contained in 07VRS:	«MPB»	«MPH»	«MPD»	«MPC»
	Contained in 08VRS:	«MPB»	«MPH»	«MPD»	«MPC»
	Supported by supply unit:	«-»			



In the firmware versions 02VRS and 03VRS, the name of the command error is "C0245 Operating mode configuration (->S-0-0022) not allowed".

02VRS / 03VRS

During the execution of the command "S-0-0128, C0200 Communication phase 4 transition check" an invalid operating mode configuration was detected.

In the operating mode parameters, it is not allowed to parameterize synchronization modes with outer position control loop (phase synchronization or electronic cam shaft) with different control encoders.

Operating mode parameters:

- S-0-0032, Primary mode of operation,
- S-0-0033, Secondary operation mode 1,
- S-0-0034, Secondary operation mode 2,
- S-0-0035, Secondary operation mode 3,
- etc.

Cause	Remedy
Operating mode configuration is invalid (phase synchronization or electronic cam shaft with different control encoders)	Parameter contents of operating mode parameters have to be changed in such a way that invalid operating mode configuration no longer occurs (respective operating mode parameters are listed in "S-0-0022, IDN list of invalid operating data for communication phase 3")
An operating mode was configured for control with encoder 2; but encoder 2 does not exist or interface has not been assigned	Select control with encoder 1 (motor encoder) or connect encoder 2 and assign interface ("P-0-0078, Assignment optional encoder ->optional slot")

Diagnostic Command Messages



If several operating modes are invalid, only the first operating mode found is entered in "S-0-0022, IDN list of invalid operating data for communication phase 3".

As of 04VRS

During the execution of the command "S-0-0422, C0200 Exit parameterization level procedure command" an invalid operating mode configuration was detected.

In the operating mode parameters, it is not allowed to parameterize synchronization modes with outer position control loop (phase synchronization or electronic cam shaft) with different control encoders.

Operating mode parameters:

- S-0-0032, Primary mode of operation,
- S-0-0033, Secondary operation mode 1,
- S-0-0034, Secondary operation mode 2,
- S-0-0035, Secondary operation mode 3,
- etc.

Cause	Remedy
Operating mode configuration is invalid (phase synchronization or electronic cam shaft with different control encoders)	Parameter contents of operating mode parameters have to be changed in such a way that invalid operating mode configuration no longer occurs (respective operating mode parameters are listed in "S-0-0423, IDN-list of invalid op. data for parameterization level")
An operating mode was configured for control with encoder 2; but encoder 2 does not exist or interface has not been assigned	Select control with encoder 1 (motor encoder) or connect encoder 2 and assign interface ("P-0-0078, Assignment optional encoder ->optional slot")



If several operating modes are invalid, only the first operating mode found is entered in "S-0-0423, IDN-list of invalid op. data for parameterization level".

See also Functional Description of firmware "Measuring Systems"

For removing command errors see "Command Errors"

C0245 - Attributes

Display: C0245
 Ident N°: C0245

10.2.89 C0246 Trav. range lim. switch not ass. to dig. input

Allocation	Contained in 02VRS:	«MPB»	«MPH»	«MPD»	
	Contained in 03VRS:	«MPB»	«MPH»	«MPD»	
	Contained in 04VRS:	«MPB»	«MPH»	«MPD»	
	Contained in 05VRS:	«MPB»	«MPH»	«MPD»	
	Contained in 06VRS:	«MPB»	«MPH»	«MPD»	«MPC»
	Contained in 07VRS:	«MPB»	«MPH»	«MPD»	«MPC»
	Contained in 08VRS:	«MPB»	«MPH»	«MPD»	«MPC»
	Supported by supply unit:	«-»			

During the execution of the command "C0200" the configuration of the digital inputs with activated travel range limit switches is checked in order to ensure the function of the travel range limit switches that are relevant for machine safety.

Diagnostic Command Messages

See also Functional Description of firmware "Digital Inputs/Outputs"

C0248 - Attributes **Display:** C0248
 Ident N°: C0248

10.2.92 C0249 Dig. I/Os: Bit number too large

Allocation	Contained in 02VRS:	«MPB»	«MPH»	«MPD»	
	Contained in 03VRS:	«MPB»	«MPH»	«MPD»	
	Contained in 04VRS:	«MPB»	«MPH»	«MPD»	
	Contained in 05VRS:	«MPB»	«MPH»	«MPD»	
	Contained in 06VRS:	«MPB»	«MPH»	«MPD»	«MPC»
	Contained in 07VRS:	«MPB»	«MPH»	«MPD»	«MPC»
	Contained in 08VRS:	«MPB»	«MPH»	«MPD»	«MPC»
	Supported by supply unit:	«-»			

During the execution of the command "C0200", the configuration of the digital I/Os is checked with regard to the configured bit numbers.

Cause	Remedy
Bit number ("P-0-0301, Digital I/Os, bit numbers") for an assigned IDN ("P-0-0300, Digital I/Os, assignment list") is not available (e.g. bit number 25 but IDN only 2 bytes long)	Check parameterization of "P-0-0300, Digital I/Os, assignment list" and "P-0-0301, Digital I/Os, bit numbers" and adjust "P-0-0301, Digital I/Os, bit numbers" to data format of corresponding IDN

For removing command errors see "Command Errors"

C0249 - Attributes **Display:** C0249
 Ident N°: C0249

10.2.93 C0250 Probe inputs incorrectly configured

Allocation	Contained in 02VRS:	«MPB»	«MPH»	«MPD»	
	Contained in 03VRS:	«MPB»	«MPH»	«MPD»	
	Contained in 04VRS:	«MPB»	«MPH»	«MPD»	
	Contained in 05VRS:	«MPB»	«MPH»	«MPD»	
	Contained in 06VRS:	«MPB»	«MPH»	«MPD»	«MPC»
	Contained in 07VRS:	«MPB»	«MPH»	«MPD»	«MPC»
	Contained in 08VRS:	«MPB»	«MPH»	«MPD»	«MPC»
	Supported by supply unit:	«-»			

During the execution of the command "C0200" an error was detected.

Cause	Remedy
At least one of both probes was activated in "S-0-0169, Probe control parameter" but not assigned to any digital input	Assign probes to digital inputs via "P-0-0300, Digital I/Os, assignment list", "P-0-0301, Digital I/Os, bit numbers" and "P-0-0302, Digital I/Os, direction"
Probes were accidentally activated	Deactivate probes in "S-0-0169, Probe control parameter"

See also Functional Description of firmware "Digital Inputs/Outputs"

See also Functional Description of firmware "Probe Function"

C0250 - Attributes **Display:** C0250
 Ident N°: C0250

10.2.94 C0251 Error during synchronization to master communication

Allocation	Contained in 02VRS:	«MPB»	«MPH»	«MPD»	
	Contained in 03VRS:	«MPB»	«MPH»	«MPD»	
	Contained in 04VRS:	«MPB»	«MPH»	«MPD»	
	Contained in 05VRS:	«MPB»	«MPH»	«MPD»	
	Contained in 06VRS:	«MPB»	«MPH»	«MPD»	«MPC»
	Contained in 07VRS:	«MPB»	«MPH»	«MPD»	«MPC»
	Contained in 08VRS:	«MPB»	«MPH»	«MPD»	«MPC»
	Supported by supply unit:	«-»			

During the execution of the command "C0200" the drive checks whether the drive control is synchronized to the bus interface (SERCOS, Profibus, Interbus,...) via two phase control loops. The synchronization process must have been completed until the end of the command. If not, this error message is generated.

Cause	Remedy
Hardware defect on control section	Replace control section or entire drive controller



Only Rexroth service engineers or especially trained users are allowed to replace the control section. The replacement of the entire drive controller is described in the Project Planning Manual for the power section.

For removing command errors see "Command Errors"

See also Functional Description of firmware "Master Communication"

C0251 - Attributes	Display:	C0251
	Ident N°:	C0251

10.2.95 C0252 Incorrect MLD initialization (write access->S-0-0423)

Allocation	Contained in 02VRS:	«-»	«-»	«-»	
	Contained in 03VRS:	«-»	«-»	«-»	
	Contained in 04VRS:	«-»	«-»	«-»	
	Contained in 05VRS:	«MPB»	«MPH»	«-»	
	Contained in 06VRS:	«MPB»	«MPH»	«-»	«MPC»
	Contained in 07VRS:	«MPB»	«MPH»	«-»	«MPC»
	Contained in 08VRS:	«MPB»	«MPH»	«-»	«MPC»
	Supported by supply unit:	«-»			

Due to an incorrect write access of the firmware (e.g. S-0-0269), switching from the parameter mode to the operating mode was prevented.



Parameter S-0-0423 displays the parameter for which write access has failed.

Cause	Remedy
Internal error or control section defective	Please contact our service department

For removing command errors see "Command Errors"

C0252 - Attributes	Display:	C0252
	Ident N°:	C0252

Diagnostic Command Messages

10.2.96 C0253 Error in combination operation mode - encoder (->S-0-0423)

Allocation	Contained in 02VRS:	«-»	«-»	«-»	
	Contained in 03VRS:	«-»	«-»	«-»	
	Contained in 04VRS:	«-»	«-»	«-»	
	Contained in 05VRS:	«MPB»	«MPH»	«MPD»	
	Contained in 06VRS:	«MPB»	«MPH»	«MPD»	«MPC»
	Contained in 07VRS:	«MPB»	«MPH»	«MPD»	«MPC»
	Contained in 08VRS:	«MPB»	«MPH»	«MPD»	«MPC»
	Supported by supply unit:	«-»			

During the check of operating mode and encoder an error occurred.



"S-0-0423, IDN-list of invalid op. data for parameterization level" contains the faulty parameter.

Cause	Remedy
Operating modes were parameterized which obligatorily require an optional encoder or operating modes were parameterized for which a certain encoder mustn't be set	<p>Correct settings for primary mode of operation and secondary oper. modes (S-0-0032 to S-0-0035 and S-0-0284 to S-0-0287)</p> <p>- or -</p> <p>"P-0-0077, Assignment motor encoder->optional slot" and "P-0-0078, Assignment optional encoder ->optional slot"</p> <p>- and -</p> <p>check motor control which was set (U/f, FXC, FOC) (see Functional Description of firmware "Motor Control")</p>

C0253 - Attributes Display: C0253
 Ident N°: C0253

10.2.97 C0254 Configuration error PROFIsafe

Allocation	Contained in 02VRS:	«-»	«-»	«-»	
	Contained in 03VRS:	«MPB»	«MPH»	«MPD»	
	Contained in 04VRS:	«MPB»	«MPH»	«MPD»	
	Contained in 05VRS:	«MPB»	«MPH»	«MPD»	
	Contained in 06VRS:	«MPB»	«MPH»	«MPD»	«MPC»
	Contained in 07VRS:	«MPB»	«MPH»	«MPD»	«MPC»
	Contained in 08VRS:	«MPB»	«MPH»	«MPD»	«MPC»
	Supported by supply unit:	«-»			

When PROFIsafe was configured, a check is run during the execution of the command "C0200" to find out whether the conditions for successful operation have been fulfilled.

Cause	Remedy
PROFIsafe was accidentally activated	Deactivate PROFIsafe (write zero to "P-0-3290, PROFIsafe: F_Destination_Address")
Control section doesn't have Profibus master communication	Replace control section; use correct hardware configuration
Due to hardware error, Profibus master communication wasn't recognized during initialization of control section	Replace control section or entire drive controller; use hardware configuration of same type



Only Rexroth service engineers or especially trained users are allowed to replace the control section. The replacement of the entire drive controller is described in the Project Planning Manual for the power section.

Only Rexroth service engineers are allowed to replace optional modules of the control section (e.g. optional encoder module).

For removing command errors see "Command Errors"

C0254 - Attributes
 Display: C0254
 Ident N°: C0254

10.2.98 C0255 Safety command for system init. incorrect

Allocation	Contained in 02VRS:	«MPB»	«MPH»	«MPD»	
	Contained in 03VRS:	«MPB»	«MPH»	«MPD»	
	Contained in 04VRS:	«MPB»	«MPH»	«MPD»	
	Contained in 05VRS:	«MPB»	«MPH»	«MPD»	
	Contained in 06VRS:	«MPB»	«MPH»	«MPD»	«MPC»
	Contained in 07VRS:	«MPB»	«MPH»	«MPD»	«MPC»
	Contained in 08VRS:	«MPB»	«MPH»	«MPD»	«MPC»
	Supported by supply unit:	«-»			

While command "C0200" was executed, an error was detected during check of the safety technology configuration.

1. Read error code entered in "P-0-3219, Extended safety technology diagnosis".
2. Based on the command error codes (here: C0255) and the error code in P-0-3219, information about the error cause and/or error location is provided as follows:
 - **Up to MPx06:** "Extended Diagnosis (P-0-3219)".
 - **As of MPx07:** "Extended Diagnosis (P-0-3219) as of MPx07".

For removing command errors see "Command Errors"

C0255 - Attributes
 Display: C0255
 Ident N°: C0255

10.2.99 C0256 Safety technology configuration error

Allocation	Contained in 02VRS:	«-»	«-»	«-»	
	Contained in 03VRS:	«MPB»	«MPH»	«MPD»	
	Contained in 04VRS:	«MPB»	«MPH»	«MPD»	
	Contained in 05VRS:	«MPB»	«MPH»	«MPD»	
	Contained in 06VRS:	«MPB»	«MPH»	«MPD»	«MPC»
	Contained in 07VRS:	«MPB»	«MPH»	«MPD»	«MPC»
	Contained in 08VRS:	«MPB»	«MPH»	«MPD»	«MPC»
	Supported by supply unit:	«-»			

During the execution of the command "C0200", an error was detected during checks of the safety technology configuration.

Cause	Remedy
For the cause, please see the documentation "Troubleshooting Guide"	Remove cause of error
Up to MPx06: "Extended Diagnosis (P-0-3219)"	
As of MPx07: "Extended Diagnosis (P-0-3219) as of MPx07"	

For removing command errors see "Command Errors"

Diagnostic Command Messages

C0256 - Attributes **Display:** C0256
Ident N°: C0256

10.2.100 C0257 Error in safety technology encoder initialization

Allocation	Contained in 02VRS:	«MPB»	«MPH»	«MPD»	
	Contained in 03VRS:	«MPB»	«MPH»	«MPD»	
	Contained in 04VRS:	«MPB»	«MPH»	«MPD»	
	Contained in 05VRS:	«MPB»	«MPH»	«MPD»	
	Contained in 06VRS:	«MPB»	«MPH»	«MPD»	«MPC»
	Contained in 07VRS:	«MPB»	«MPH»	«MPD»	«MPC»
	Contained in 08VRS:	«MPB»	«MPH»	«MPD»	«MPC»
	Supported by supply unit:	«-»			



In firmware versions 02VRS, 03VRS and 04VRS, the name of the command error is "C0257 No encoder assigned to slot 1".

While command "C0200" was executed, an error was detected during encoder-related safety technology initialization.

Cause	Remedy
There is no encoder plugged in optional slot X4 (X4.1 and X4.2 in double-axis device)	Remove cause of error
Encoder plugged in optional slot X4 (X4.1 and X4.2 in double axis-device) is not configured because either encoder type (P-0-0074, P-0-0075) or encoder assignment (P-0-0077, P-0-0078) is "0".	Remove cause of error
Encoder plugged in optional slot X4 (X4.1 and X4.2 in double-axis device) is not allowed See also documentation "Integrated Safety Technology", index entry "Requirements of safety technology, measuring system"	Remove cause of error



When using the optional module "safety technology I/O" (S1) (up to MPx06) or "Safe Motion" (S2) (as of MPx07), you can, in addition to the error message, obtain detailed information with regard to the cause of the error or the error location. For this purpose, evaluate parameter "P-0-3219, Diagnostic safety technology message".

Up to MPx06: See "Extended Diagnosis (P-0-3219)".

As of MPx07: See "Extended Diagnosis (P-0-3219) as of MPx07".

For removing command errors see "Command Errors"

C0257 - Attributes **Display:** C0257
Ident N°: C0257

10.2.101 C0258 Error in relation TNcyc (S-0-0001) to fine interpol.

Allocation	Contained in 02VRS:	«MPB»	«MPH»	«MPD»	
	Contained in 03VRS:	«MPB»	«MPH»	«MPD»	
	Contained in 04VRS:	«MPB»	«MPH»	«MPD»	
	Contained in 05VRS:	«MPB»	«MPH»	«MPD»	
	Contained in 06VRS:	«MPB»	«MPH»	«MPD»	«MPC»
	Contained in 07VRS:	«MPB»	«MPH»	«MPD»	«MPC»
	Contained in 08VRS:	«MPB»	«MPH»	«MPD»	«MPC»
	Supported by supply unit:	«-»			

During the execution of the command "C0200", a check is run, when the cubic fine interpolator or the interpolator according to contour ("P-0-0187, Position command processing mode" = "1" or "2") is used, to find out whether the selected NC cycle time is supported by the respective fine interpolator.

Cause	Remedy
"S-0-0001, NC cycle time (TNcyc)" incorrectly parameterized	Select appropriate "S-0-0001, NC cycle time (TNcyc)". Allowed NC cycle times, when using cubic fine interpolator or fine interpolator according to contour, depend on relation of NC cycle time (S-0-0001) and position loop clock (P-0-0556, Control word of axis controller). Allowed clock relations: <ul style="list-style-type: none"> • From 1 to 8 in steps of one • From 10 to 16 in steps of two • From 20 to 32 in steps of four Example [allowed NC cycle times with Advanced performance (position loop clock=250 µs)]: <ul style="list-style-type: none"> • 250 µs to 2000 µs • 2500 µs to 4000 µs • 5000 µs to 8000 µs
Cubic fine interpolation or fine interpolation according to contour cannot be used with present NC cycle time ("S-0-0001, NC cycle time (TNcyc)")	Use linear fine interpolator ("P-0-0187, Position command processing mode" = "0")

For removing command errors see "Command Errors"

C0258 - Attributes	Display:	C0258
	Ident N°:	C0258

10.2.102 C0259 MLD configuration error (->S-0-0423)

Allocation	Contained in 02VRS:	«-»	«-»	«-»	
	Contained in 03VRS:	«-»	«-»	«-»	
	Contained in 04VRS:	«-»	«-»	«-»	
	Contained in 05VRS:	«MPB»	«MPH»	«-»	
	Contained in 06VRS:	«MPB»	«MPH»	«-»	«MPC»
	Contained in 07VRS:	«MPB»	«MPH»	«-»	«MPC»
	Contained in 08VRS:	«MPB»	«MPH»	«-»	«MPC»
	Supported by supply unit:	«-»			

The execution of the command "C0200" (switching from parameter mode to operating mode) was impeded due to an incorrect MLD configuration.



In S-0-0423, the incorrectly configured parameters are listed.

Diagnostic Command Messages

Cause	Remedy
In "P-0-1367, PLC configuration" , permanent control was set, but in "P-0-4084, Field bus: profile type" the "operating mode neutral" profile was not set (P-0-4084=FFFD)	(Local) axis can be controlled either via field bus (P-0-4084=FFFE) or via MLD (P-0-1367, bit 4=1); it is impossible to have both settings at the same time
In "P-0-1367, PLC configuration" , "boot project on MMC" was set, but in "P-0-4070, Parameter storage configuration" "programming module mode" was not set	To store boot project on an MMC, the MMC must be permanently available and in P-0-4070 you must have set "programming module mode"; otherwise, boot project cannot be stored on an MMC, but only in PLC parameters

For removing command errors see "Command Errors"

C0259 - Attributes Display: C0259
 Ident N°: C0259

10.2.103 C0260 Incremental enc. emulator resol. cannot be displayed

Allocation	Contained in 02VRS:	«MPB»	«MPH»	«MPD»	
	Contained in 03VRS:	«MPB»	«MPH»	«MPD»	
	Contained in 04VRS:	«MPB»	«MPH»	«MPD»	
	Contained in 05VRS:	«MPB»	«MPH»	«MPD»	
	Contained in 06VRS:	«MPB»	«MPH»	«MPD»	«MPC»
	Contained in 07VRS:	«MPB»	«MPH»	«MPD»	«MPC»
	Contained in 08VRS:	«MPB»	«MPH»	«MPD»	«MPC»
	Supported by supply unit:	«-»			

In the case of incremental encoder emulation, inadmissible overflow can occur for increment output. In order to avoid this overflow, "P-0-0903, Encoder emulation resolution" has to be parameterized accordingly.

In the case of modulo processing, the overflow takes place at the modulo value entered in "S-0-0103, Modulo value":

$$P-0-0903 = \frac{S-0-0079}{S-0-0103} * 2^{29}$$

- S-0-0103 "S-0-0103, Modulo value"
- P-0-0903 "P-0-0903, Encoder emulation resolution"
- S-0-0079 "S-0-0079, Rotational position resolution"

Fig. 10-3: *Overflow in the case of modulo processing*

Otherwise, the overflow takes place at the value entered in "S-0-0278, Maximum travel range":

$$P-0-0903 = \frac{S-0-0079}{S-0-0278} * 2^{29}$$

- P-0-0903 "P-0-0903, Encoder emulation resolution"
- S-0-0079 "S-0-0079, Rotational position resolution"
- S-0-0278 "S-0-0278, Maximum travel range"

Fig. 10-4: *Overflow in case of maximum travel range*

Diagnostic Command Messages

Cause	Remedy
Resolution of emulated signal does not match modulo range / travel range	Reduce resolution entered in "P-0-0901.0.3, Encoder emulation resolution" - or - Reduce "S-0-0278, Maximum travel range"

See also Functional Description of firmware "Incremental Encoder Emulation"

C0260 - Attributes Display: C0260
 Ident N°: C0260

10.2.104 C0261 Emulator (P-0-0902) activated for both axes

Allocation	Contained in 02VRS:	«-»	«-»	«MPD»	
	Contained in 03VRS:	«-»	«-»	«-»	
	Contained in 04VRS:	«-»	«-»	«-»	
	Contained in 05VRS:	«-»	«-»	«-»	
	Contained in 06VRS:	«-»	«-»	«-»	«-»
	Contained in 07VRS:	«-»	«-»	«-»	«-»
	Contained in 08VRS:	«-»	«-»	«-»	«-»
	Supported by supply unit:	«-»			

Cause	Remedy
For double axis devices encoder emulation can only be activated in one axis. Encoder emulation was activated in both axes	Deactivate encoder emulation in one of both axes ("P-0-0902, Encoder emulation control parameter")

See also Functional Description of firmware "Incremental Encoder Emulation"

C0261 - Attributes Display: C0261
 Ident N°: C0261

10.2.105 C0265 Incorrect CCD address configuration

Allocation	Contained in 02VRS:	«-»	«-»	«-»	
	Contained in 03VRS: <td>«-» <td>«-» <td>«-»</td> </td></td>	«-» <td>«-» <td>«-»</td> </td>	«-» <td>«-»</td>	«-»	
	Contained in 04VRS: <td>«-»</td> <td>«MPH»</td> <td>«-»</td>	«-»	«MPH»	«-»	
	Contained in 05VRS: <td>«-»</td> <td>«MPH»</td> <td>«-»</td>	«-»	«MPH»	«-»	
	Contained in 06VRS: <td>«-»</td> <td>«-»</td> <td>«-»</td> <td>«MPC»</td>	«-»	«-»	«-»	«MPC»
	Contained in 07VRS: <td>«-»</td> <td>«-»</td> <td>«-»</td> <td>«MPC»</td>	«-»	«-»	«-»	«MPC»
	Contained in 08VRS: <td>«-»</td> <td>«-»</td> <td>«-»</td> <td>«MPC»</td>	«-»	«-»	«-»	«MPC»
	Supported by supply unit:	«-»			

While command "S-0-0422, C0200 Exit parameterization level procedure command" was executed, an error with regard to the drive cross-communication [CCD (Cross Communication Drives)] was detected.

Cause	Remedy
"P-0-1601, CCD: Addresses of projected drives" or "P-0-1604, CCD: Addresses of projected I/Os" (as of MPx05) of the CCD master contains the address of a SERCOS III slave which is not contained in "P-0-1636, CCD: Command topology addresses". - or - The same address is entered in "P-0-1601, CCD: Addresses of projected drives" and "P-0-1604, CCD: Addresses of projected I/Os".	Check "P-0-1601, CCD: Addresses of projected drives" or "P-0-1604, CCD: Addresses of projected I/Os" (as of MPx05) and addresses of connected slaves; if necessary, change address on slave or assign remote address. Note: When the address of a slave is changed, a new SERCOS III phase progression must be carried out via phase 0. Phase 0 scans the connected slaves.

Diagnostic Command Messages

See also Functional Description of firmware "Cross Communication (CCD)"

C0265 - Attributes **Display:** C0265
Ident N°: C0265

10.2.106 C0266 Incorrect CCD phase switch

Allocation	Contained in 02VRS:	«-»	«-»	«-»	
	Contained in 03VRS:	«-»	«-»	«-»	
	Contained in 04VRS:	«-»	«MPH»	«-»	
	Contained in 05VRS:	«-»	«MPH»	«-»	
	Contained in 06VRS:	«-»	«MPH»	«-»	«MPC»
	Contained in 07VRS:	«-»	«MPH»	«-»	«MPC»
	Contained in 08VRS:	«-»	«MPH»	«-»	«MPC»
	Supported by supply unit:	«-»			

While command "S-0-0422, C0200 Exit parameterization level procedure command" was executed, an error with regard to the drive cross-communication [CCD (Cross Communication Drives)] was detected.

Cause	Remedy
<p>After command "C0200 Exit parameterization level procedure command" is started, CCD master attempts to put SERCOS III slaves to phase 4 by starting commands C01 and C52 in CCD slaves; here, values are written to all required slave parameters.</p> <p>Command error occurred in CCD slave during one of these actions.</p>	<p>Check up "P-0-1630, CCD: Diagnosis" correct rejected parameter, if any.</p> <p>- or -</p> <p>Check configuration of CCD process data:</p> <ul style="list-style-type: none"> • P-0-1621, CCD: configuration list master communication cmd values • P-0-1622, CCD: configuration list master communication actual values • P-0-1623, CCD: configuration list master cmd values • P-0-1624, CCD: configuration list actual master values • P-0-1625, CCD: configuration list slave cmd values • P-0-1626, CCD: configuration list actual slave values <p>- or -</p> <p>Eliminate cause of command error in CCD slave.</p>

See also Functional Description of firmware "Cross Communication (CCD)"

C0266 - Attributes **Display:** C0266
Ident N°: C0266

10.2.107 C0267 CCD timeout phase switch

Allocation	Contained in 02VRS:	«-»	«-»	«-»	
	Contained in 03VRS:	«-»	«-»	«-»	
	Contained in 04VRS:	«-»	«MPH»	«-»	
	Contained in 05VRS:	«-»	«MPH»	«-»	
	Contained in 06VRS:	«-»	«-»	«-»	«MPC»
	Contained in 07VRS:	«-»	«-»	«-»	«MPC»
	Contained in 08VRS:	«-»	«-»	«-»	«MPC»
	Supported by supply unit:	«-»			

Command "S-0-0422, C0200 Exit parameterization level procedure command" was executed without any errors in SERCOS III master. Master did not generate any error during phase switching (C0266).

Diagnostic Command Messages

The maximum delay time (60 seconds) for switching the SERCOS III slaves to phase 4 has elapsed but one or more slaves which did not enter phase 4 yet.

Cause	Remedy
One or more SERCOS III slaves entered in "P-0-1601, CCD: Addresses of projected drives" or "P-0-1604, CCD: Addresses of projected I/Os" (as of MPx05) do not react to service channel communication	Locate defective SERCOS-III slave(s) and remove cause of error for this (these) slave(s)
Transition command "S-0-0127, C0100 Communication phase 3 transition check" or "S-0-0128, C5200 Communication phase 4 transition check" is not completed or only completed with error in one or more SERCOS III slaves	Locate defective SERCOS-III slave(s) and remove cause of error for this (these) slave(s)

See also Functional Description of firmware "Cross Communication (CCD)"

C0267 - Attributes **Display:** C0267
 Ident N°: C0267

10.2.108 C0270 Error when reading encoder data => motor encoder

Allocation	Contained in 02VRS:	«-»	«-»	«-»	
	Contained in 03VRS:	«MPB»	«MPH»	«MPD»	
	Contained in 04VRS:	«MPB»	«MPH»	«MPD»	
	Contained in 05VRS:	«MPB»	«MPH»	«MPD»	
	Contained in 06VRS:	«MPB»	«MPH»	«MPD»	«MPC»
	Contained in 07VRS:	«MPB»	«MPH»	«MPD»	«MPC»
	Contained in 08VRS:	«MPB»	«MPH»	«MPD»	«MPC»
	Supported by supply unit:	«-»			

During the execution of the command "C0200" an error during the reading of the encoder data from the data memory of the motor encoder was detected.



Measuring systems with their own data memory are DSF/HSF and resolvers, as well as measuring systems with EnDat interface (Heidenhain company) and HIPERFACE® interface (Stegmann company).

Cause	Remedy
Measuring system cable defective	Check measuring system cable
Measuring system defective	Replace measuring system
Encoder interface defective	Replace control section or entire drive controller



Only Rexroth service engineers or especially trained users are allowed to replace the control section. The replacement of the entire drive controller is described in the Project Planning Manual for the power section.

C0270 - Attributes **Display:** C0270
 Ident N°: C0270

Diagnostic Command Messages

10.2.109 C0271 Incorrect parameterization of motor encoder (hardware)

Allocation	Contained in 02VRS:	«-»	«-»	«-»	
	Contained in 03VRS:	«MPB»	«MPH»	«MPD»	
	Contained in 04VRS:	«MPB»	«MPH»	«MPD»	
	Contained in 05VRS:	«MPB»	«MPH»	«MPD»	
	Contained in 06VRS:	«MPB»	«MPH»	«MPD»	«MPC»
	Contained in 07VRS:	«MPB»	«MPH»	«MPD»	«MPC»
	Contained in 08VRS:	«MPB»	«MPH»	«MPD»	«MPC»
	Supported by supply unit:	«-»			

During the execution of the command "C0200" an error with regard to the parameterization of the motor encoder hardware was detected.

Cause	Remedy
Parameterization "P-0-0074, Encoder type 1 (motor encoder)" does not match interface card (e.g. EN1 with EnDat encoder)	Check whether parameterized encoder type matches interface card that has been plugged in
In the case of "current control with motor encoder" (see "P-0-0045, Control word of current controller"), "operation without encoder" was detected to have been set in "P-0-0074, Encoder type 1 (motor encoder)"	Enter value appropriate for motor encoder in "P-0-0074, Encoder type 1 (motor encoder)"
Parameterization in "P-0-0077, Assignment motor encoder->optional slot" is incorrect	Correct assignment of motor encoder and optional slot in parameter "P-0-0077, Assignment motor encoder->optional slot"

C0271 - Attributes Display: C0271
 Ident N°: C0271

10.2.110 C0272 Incorr. parameteriz. of motor enc. (mechanical system)

Allocation	Contained in 02VRS:	«-»	«-»	«-»	
	Contained in 03VRS:	«MPB»	«MPH»	«MPD»	
	Contained in 04VRS:	«MPB»	«MPH»	«MPD»	
	Contained in 05VRS:	«MPB»	«MPH»	«MPD»	
	Contained in 06VRS:	«MPB»	«MPH»	«MPD»	«MPC»
	Contained in 07VRS:	«MPB»	«MPH»	«MPD»	«MPC»
	Contained in 08VRS:	«MPB»	«MPH»	«MPD»	«MPC»
	Supported by supply unit:	«-»			

During the execution of the command "C0200" an error was detected with regard to the scaling that has been set and the selected motor encoder type (e.g. rotary scaling with linear motor).

Cause	Remedy
Incorrect encoder type ("S-0-0277, Position feedback 1 type")	Check and, if necessary, correct "S-0-0277, Position feedback 1 type"
Parameterized scaling ("S-0-0076, Position data scaling type") is incorrect	Check and, if necessary, correct "S-0-0076, Position data scaling type"
Parameterized type of construction of motor ("P-0-4014, Type of construction of motor") is not correct	Correct "P-0-4014, Type of construction of motor"
Maximum travel range ("S-0-0278, Maximum travel range") was incorrectly input	Make input greater than "0" for "S-0-0278, Maximum travel range"

For removing command errors see "Command Errors"

C0272 - Attributes **Display:** C0272
 Ident N°: C0272

10.2.111 C0273 Modulo value for motor encoder cannot be displayed

Allocation	Contained in 02VRS:	«-»	«-»	«-»	
	Contained in 03VRS:	«MPB»	«MPH»	«MPD»	
	Contained in 04VRS:	«MPB»	«MPH»	«MPD»	
	Contained in 05VRS:	«MPB»	«MPH»	«MPD»	
	Contained in 06VRS:	«MPB»	«MPH»	«MPD»	«MPC»
	Contained in 07VRS:	«MPB»	«MPH»	«MPD»	«MPC»
	Contained in 08VRS:	«MPB»	«MPH»	«MPD»	«MPC»
	Supported by supply unit:	«-»			

During the execution of the command "C0200" an error with regard to the modulo value for the motor encoder was detected.

Cause	Remedy
Parameterized value for "S-0-0103, Modulo value" is greater than maximum travel range (cf. "S-0-0278, Maximum travel range")	Correct content of "S-0-0103, Modulo value" or value of "S-0-0278, Maximum travel range"
Parameterized value for "S-0-0103, Modulo value" cannot be internally displayed with gear ratios that have been set (S-0-0121/S-0-0122, P-0-0121/P-0-0122)	Correct content of "S-0-0103, Modulo value" or gear ratios that have been set ["S-0-0121, Input revolutions of load gear"/"S-0-0122, Output revolutions of load gear"; "P-0-0121, Gear 1 motor-side (motor encoder)"/"P-0-0122, Gear 1 encoder-side (motor encoder)"]

For removing command errors see "Command Errors"

C0273 - Attributes **Display:** C0273
 Ident N°: C0273

10.2.112 C0274 Motor encoder unknown

Allocation	Contained in 02VRS:	«-»	«-»	«-»	
	Contained in 03VRS:	«MPB»	«MPH»	«MPD»	
	Contained in 04VRS:	«MPB»	«MPH»	«MPD»	
	Contained in 05VRS:	«MPB»	«MPH»	«MPD»	
	Contained in 06VRS:	«MPB»	«MPH»	«MPD»	«MPC»
	Contained in 07VRS:	«MPB»	«MPH»	«MPD»	«MPC»
	Contained in 08VRS:	«MPB»	«MPH»	«MPD»	«MPC»
	Supported by supply unit:	«-»			

During the execution of the command "C0200" an error with regard to the motor encoder was detected. The content of "P-0-1000, Kind of encoder 1, encoder memory" is invalid and therefore the parameterized motor encoder is not allowed (e.g. rotary scaling with linear encoder).

Cause	Remedy
Encoder memory (feedback) is defective	Encoder (or motor) must be replaced
Kind of motor encoder ("P-0-1000, Kind of encoder 1, encoder memory") is not supported by the firmware	Check content of "P-0-1000, Kind of encoder 1, encoder memory" and contact our service department
Detected kind of encoder does not match parameterized type of encoder	Check control section configuration and, if necessary, replace control section by a correctly configured control section or replace complete drive controller

Diagnostic Command Messages



Only Rexroth service engineers or especially trained users are allowed to replace the control section. The replacement of the entire drive controller is described in the Project Planning Manual for the power section.

For removing command errors see "Command Errors"

C0274 - Attributes
Display: C0274
Ident N°: C0274

10.2.113 C0275 Error when reading encoder data => optional encoder

Allocation	Contained in 02VRS:	«-»	«-»	«-»	
	Contained in 03VRS:	«MPB»	«MPH»	«MPD»	
	Contained in 04VRS:	«MPB»	«MPH»	«MPD»	
	Contained in 05VRS:	«MPB»	«MPH»	«MPD»	
	Contained in 06VRS:	«MPB»	«MPH»	«MPD»	«MPC»
	Contained in 07VRS:	«MPB»	«MPH»	«MPD»	«MPC»
	Contained in 08VRS:	«MPB»	«MPH»	«MPD»	«MPC»
	Supported by supply unit:	«-»			

During the execution of the command "C0200" an error during the reading of the encoder data from the data memory of the optional encoder was detected.



Measuring systems with their own data memory are DSF/HSF and resolvers, as well as measuring systems with EnDat interface (Heidenhain company) and HIPERFACE® interface (Stegmann company).

Cause	Remedy
Measuring system cable defective	Check measuring system cable
Measuring system defective	Replace measuring system
Encoder interface defective	Replace control section or entire drive controller



Only Rexroth service engineers or especially trained users are allowed to replace the control section. The replacement of the entire drive controller is described in the Project Planning Manual for the power section.

C0275 - Attributes
Display: C0275
Ident N°: C0275

10.2.114 C0276 Incorrect parameterization of optional enc. (hardware)

Allocation	Contained in 02VRS:	«-»	«-»	«-»	
	Contained in 03VRS:	«MPB»	«MPH»	«MPD»	
	Contained in 04VRS:	«MPB»	«MPH»	«MPD»	
	Contained in 05VRS:	«MPB»	«MPH»	«MPD»	
	Contained in 06VRS:	«MPB»	«MPH»	«MPD»	«MPC»
	Contained in 07VRS:	«MPB»	«MPH»	«MPD»	«MPC»
	Contained in 08VRS:	«MPB»	«MPH»	«MPD»	«MPC»
	Supported by supply unit:	«-»			

During the execution of the command "C0200" an error with regard to the parameterization of the hardware of the optional encoder was detected.

Diagnostic Command Messages

Cause	Remedy
Parameterization "P-0-0075, Encoder type 2 (optional encoder)" does not match encoder interface (e.g. EN1 with En-Dat encoder)	Correct parameterization of "P-0-0075, Encoder type 2 (optional encoder)"
"P-0-0078, Assignment optional encoder->optional slot" incorrect	Correct parameterization of "P-0-0078, Assignment optional encoder->optional slot"

See also Functional Description of firmware "Measurement Systems"

C0276 - Attributes **Display:** C0276
 Ident N°: C0276

10.2.115 C0277 Incorr. parameteriz. of opt. enc. (mechanical system)

Allocation	Contained in 02VRS:	«-»	«-»	«-»	
	Contained in 03VRS:	«MPB»	«MPH»	«MPD»	
	Contained in 04VRS:	«MPB»	«MPH»	«MPD»	
	Contained in 05VRS:	«MPB»	«MPH»	«MPD»	
	Contained in 06VRS:	«MPB»	«MPH»	«MPD»	«MPC»
	Contained in 07VRS:	«MPB»	«MPH»	«MPD»	«MPC»
	Contained in 08VRS:	«MPB»	«MPH»	«MPD»	«MPC»
	Supported by supply unit:	«-»			

During the execution of the command "C0200" an error was detected with regard to scaling that was set and the selected motor encoder type (e.g. rotary scaling with linear optional encoder).

Cause	Remedy
Incorrect encoder type ("S-0-0115, Position feedback 2 type")	Check and, if necessary, correct "S-0-0115, Position feedback 2 type"
Parameterized scaling ("S-0-0076, Position data scaling type") is incorrect	Check and, if necessary, correct "S-0-0076, Position data scaling type"

For removing command errors see "Command Errors"

C0277 - Attributes **Display:** C0277
 Ident N°: C0277

10.2.116 C0278 Modulo value for optional encoder cannot be displayed

Allocation	Contained in 02VRS:	«-»	«-»	«-»	
	Contained in 03VRS:	«MPB»	«MPH»	«MPD»	
	Contained in 04VRS:	«MPB»	«MPH»	«MPD»	
	Contained in 05VRS:	«MPB»	«MPH»	«MPD»	
	Contained in 06VRS:	«MPB»	«MPH»	«MPD»	«MPC»
	Contained in 07VRS:	«MPB»	«MPH»	«MPD»	«MPC»
	Contained in 08VRS:	«MPB»	«MPH»	«MPD»	«MPC»
	Supported by supply unit:	«-»			

During the execution of the command "C0200" an error with regard to the modulo value for the optional encoder was detected.

Diagnostic Command Messages

Cause	Remedy
Parameterized value for "S-0-0103, Modulo value" is greater than maximum travel range (cf. "S-0-0278, Maximum travel range")	Correct content of "S-0-0103, Modulo value" or value of S-0-0278, Maximum travel range"
Parameterized value for "S-0-0103, Modulo value" cannot be internally displayed with gear ratios that have been set (S-0-0121/S-0-0122, P-0-0121/P-0-0122)	Correct content of "S-0-0103, Modulo value" or gear ratios that have been set ["S-0-0121, Input revolutions of load gear"/"S-0-0122, Output revolutions of load gear"; "P-0-0121, Gear 1 motor-side (motor encoder)"/"P-0-0122, Gear 1 encoder-side (motor encoder)"]
Encoder resolution ("S-0-0117, Feedback 2 Resolution") in- correctly parameterized	Check and, if necessary, correct parameterization of "S-0-0117, Feedback 2 Resolution"
Resolution of encoder does not match required modulo range	Replace encoder

For removing command errors see "Command Errors"

See also Functional Description of firmware "Scaling"

C0278 - Attributes Display: C0278
 Ident N°: C0278

10.2.117 C0279 Optional encoder unknown

Allocation	Contained in 02VRS:	«-»	«-»	«-»	
	Contained in 03VRS:	«MPB»	«MPH»	«MPD»	
	Contained in 04VRS:	«MPB»	«MPH»	«MPD»	
	Contained in 05VRS:	«MPB»	«MPH»	«MPD»	
	Contained in 06VRS:	«MPB»	«MPH»	«MPD»	«MPC»
	Contained in 07VRS:	«MPB»	«MPH»	«MPD»	«MPC»
	Contained in 08VRS:	«MPB»	«MPH»	«MPD»	«MPC»
	Supported by supply unit:	«-»			

During the execution of the command "C0200" an error with regard to the optional encoder was detected. The content of "P-0-1010, Kind of encoder 2, encoder memory" is invalid and therefore the parameterized optional encoder is not allowed (e.g. rotary scaling with linear encoder).

Cause	Remedy
Encoder memory (feedback) is defective	Encoder must be replaced
Kind of motor encoder ("P-0-1010, Kind of encoder 2, encoder memory") is not supported by firmware	Check content of "P-0-1010, Kind of encoder 2, encoder memory" and contact our service department
Detected kind of encoder does not match parameterized type of encoder	Check control section configuration and, if necessary, re- place control section by a correctly configured control sec- tion or replace complete drive controller



Only Rexroth service engineers or especially trained users are al- lowed to replace the control section. The replacement of the en- tire drive controller is described in the Project Planning Manual for the power section.

For removing command errors see "Command Errors"

C0279 - Attributes Display: C0279
 Ident N°: C0279

10.2.118 C0280 Maximum travel range cannot be displayed internally

Allocation	Contained in 02VRS:	«-»	«-»	«-»	
	Contained in 03VRS:	«MPB»	«MPH»	«MPD»	
	Contained in 04VRS:	«MPB»	«MPH»	«MPD»	
	Contained in 05VRS:	«MPB»	«MPH»	«MPD»	
	Contained in 06VRS:	«MPB»	«MPH»	«MPD»	«MPC»
	Contained in 07VRS:	«MPB»	«MPH»	«MPD»	«MPC»
	Contained in 08VRS:	«MPB»	«MPH»	«MPD»	«MPC»
	Supported by supply unit:	«-»			

In the case of absolute scaling, the maximum travel range represents the overflow limit of the actual position values. If this travel range cannot be displayed correctly internally so that position generation without error is impossible, this error is generated.

Cause	Remedy
"S-0-0278, Maximum travel range" incorrectly parameterized	Check and if necessary reduce "S-0-0278, Maximum travel range"
S-0-0116 / S-0-0117 incorrectly set (e.g. value "0")	Check and if necessary correct "S-0-0116, Feedback 1 Resolution" / "S-0-0117, Feedback 2 Resolution"
Value for "S-0-0278, Maximum travel range" is invalid although it might be within the respective absolute encoder range	Check "S-0-0278, Maximum travel range" and if necessary change value (take respective absolute encoder range into account!)
Position resolution of a pole pair or of pole pair distance is too low. Commutation offset value internally cannot be displayed precisely enough	"P-0-0018, Number of pole pairs/pole pair distance" has value "0" or a too small value (maybe incorrect unit). Check and if necessary correct "P-0-0018, Number of pole pairs/pole pair distance"

See also Functional Description of firmware "Scaling"

For removing command errors see "Command Errors"

C0280 - Attributes	Display:	C0280
	Ident N°:	C0280

10.2.119 C0281 Commutation via encoder-2 impossible

Allocation	Contained in 02VRS:	«-»	«-»	«-»	
	Contained in 03VRS:	«-»	«-»	«-»	
	Contained in 04VRS:	«MPB»	«MPH»	«MPD»	
	Contained in 05VRS:	«MPB»	«MPH»	«MPD»	
	Contained in 06VRS:	«MPB»	«MPH»	«MPD»	«MPC»
	Contained in 07VRS:	«MPB»	«MPH»	«MPD»	«MPC»
	Contained in 08VRS:	«MPB»	«MPH»	«MPD»	«MPC»
	Supported by supply unit:	«-»			

Commutation or commutation initialization via encoder 2 is impossible.

Cause	Remedy
Parameterized mechanical system does not allow unequivocal commutation via optional measuring system	<ul style="list-style-type: none"> Reduce maximum travel range ("S-0-0278, Maximum travel range") Adjust gear ("S-0-0121, Input revolutions of load gear"; "S-0-0122, Output revolutions of load gear"; ...) Use appropriate encoder (e.g. multi-turn)

Diagnostic Command Messages

C0281 - Attributes **Display:** C0281
Ident N°: C0281

10.2.120 C0282 Sensorless posit. of synchr. motors, invalid ctrl parameters

Allocation	Contained in 02VRS:	«-»	«-»	«-»	
	Contained in 03VRS:	«-»	«-»	«-»	
	Contained in 04VRS:	«-»	«-»	«-»	
	Contained in 05VRS:	«MPB»	«MPH»	«MPD»	
	Contained in 06VRS:	«MPB»	«MPH»	«MPD»	«MPC»
	Contained in 07VRS:	«MPB»	«MPH»	«MPD»	«MPC»
	Contained in 08VRS:	«MPB»	«MPH»	«MPD»	«MPC»
	Supported by supply unit:	«-»			

During the execution of the command "S-0-0422, C0200 Exit parameterization level procedure command" an error was detected in the parameterization of sensorless positioning of synchronous motors.

Cause	Remedy
Sensorless positioning of synchronous motors was incorrectly parameterized	Use parameter file made available by Bosch Rexroth
Incorrect motor control mode was parameterized	Check parameters P-0-0045, P-0-4014 and P-0-0074
Parameter file made available by Bosch Rexroth is defective	Please contact our service department

C0282 - Attributes **Display:** C0282
Ident N°: C0282

10.2.121 C0283 Error during initialization of motor control (->S-0-0423)

Allocation	Contained in 02VRS:	«-»	«-»	«-»	
	Contained in 03VRS:	«-»	«-»	«-»	
	Contained in 04VRS:	«-»	«-»	«-»	
	Contained in 05VRS:	«MPB»	«MPH»	«MPD»	
	Contained in 06VRS:	«MPB»	«MPH»	«MPD»	«MPC»
	Contained in 07VRS:	«MPB»	«MPH»	«MPD»	«MPC»
	Contained in 08VRS:	«MPB»	«MPH»	«MPD»	«MPC»
	Supported by supply unit:	«-»			

During the execution of the command "S-0-0422, C0200 Exit parameterization level procedure command" or "S-0-0128, C5200 Communication phase 4 transition check" an error was detected.

During the command, the following parameters are checked for consistency:

- P-0-0045, Control word of current controller
- P-0-0074, Encoder type 1 (motor encoder)
- P-0-4014, Type of construction of motor
- P-0-3980, FOCsl: configuration word
- P-0-2003, Selection of functional packages



If inconsistencies in the parameter setting are detected, the parameters are entered in parameter "S-0-0423, IDN-list of invalid op. data for parameterization level".

Diagnostic Command Messages

Cause	Remedy
An error was detected during adjust of type of construction of motor, encoder type, kind of current control	Check and correct parameters in "S-0-0423, IDN-list of invalid op. data for parameterization level"
An error was detected in enabling of functional packages	There was an attempt to activate sensorless positioning of synchronous motors in functional package open-loop. Check and correct parameters in "S-0-0423, IDN-list of invalid op. data for parameterization level"

For removing command errors see "Command Errors"

C0283 - Attributes **Display:** C0283
 Ident N°: C0283

10.2.122 C0284 Invalid motor data in encoder memory (->S-0-0423)

Allocation	Contained in 02VRS:	«-»	«-»	«-»	
	Contained in 03VRS:	«MPB»	«MPH»	«MPD»	
	Contained in 04VRS:	«MPB»	«MPH»	«MPD»	
	Contained in 05VRS:	«MPB»	«MPH»	«MPD»	
	Contained in 06VRS:	«MPB»	«MPH»	«MPD»	«MPC»
	Contained in 07VRS:	«MPB»	«MPH»	«MPD»	«MPC»
	Contained in 08VRS:	«MPB»	«MPH»	«MPD»	«MPC»
	Supported by supply unit:	«-»			



In the firmware versions 02VRS and 03VRS, the name of the command error is "C0284 Invalid motor data in encoder memory (->S-0-0022)".

02VRS / 03VRS

During the transition check from communication phase 3 to communication phase 4 (C0200) an error during the reading of the motor data from the data memory of the motor encoder was detected.

The respective parameters are entered in "S-0-0022, IDN list of invalid operating data for communication phase 3".

Cause	Remedy
Measuring system cable defective	Replace measuring system cable
Measuring system defective	Replace measuring system
Encoder interface defective	Replace control section or entire drive controller



Only Rexroth service engineers or especially trained users are allowed to replace the control section. The replacement of the entire drive controller is described in the Project Planning Manual for the power section.

As of 04VRS

During the execution of the command "C0200" an error during the reading of the motor data from the data memory of the motor encoder was detected

The respective parameters are entered in parameter "S-0-0423, IDN-list of invalid op. data for parameterization level".

Diagnostic Command Messages

Cause	Remedy
Measuring system cable defective	Replace measuring system cable
Measuring system defective	Replace measuring system
Encoder interface defective	Replace control section or entire drive controller



Only Rexroth service engineers or especially trained users are allowed to replace the control section. The replacement of the entire drive controller is described in the Project Planning Manual for the power section.

For removing command errors see "Command Errors"

C0284 - Attributes

Display: C0284
Ident N°: C0284

10.2.123 C0285 Type of construction of motor P-0-4014 incorrect

Allocation	Contained in 02VRS:	«-»	«-»	«-»	
	Contained in 03VRS:	«MPB»	«MPH»	«MPD»	
	Contained in 04VRS:	«MPB»	«MPH»	«MPD»	
	Contained in 05VRS:	«MPB»	«MPH»	«MPD»	
	Contained in 06VRS:	«MPB»	«MPH»	«MPD»	«MPC»
	Contained in 07VRS:	«MPB»	«MPH»	«MPD»	«MPC»
	Contained in 08VRS:	«MPB»	«MPH»	«MPD»	«MPC»
	Supported by supply unit:	«-»			

02VRS / 03VRS

During the execution of the command "S-0-0128, C0200 Communication phase 4 transition check" an error was detected in "P-0-4014, Type of construction of motor".



The respective parameter is entered in "S-0-0022, IDN list of invalid operating data for communication phase 3".

Cause	Remedy
A motor without encoder data memory was connected	Parameterize "P-x-4014, Type of construction of motor" correctly or connect a motor with encoder data memory. Note: "x" in parameter number is a wild card for parameter set; e.g. "P-0-4014" for first parameter set.
A motor with encoder data memory was connected, but data stored in memory are incomplete or encoder line resp. encoder is defective	Check whether "P-0-2141, Motor type, encoder memory" contains correct type designation of connected motor. If not, contact our service department. If "P-0-2141, Motor type, encoder memory" cannot be read, replace encoder line or motor encoder

As of 04VRS

During the execution of the command "S-0-0422, C0200 Exit parameterization level procedure command" or "S-0-0128, C5200 Communication phase 4 transition check" an error in the parameterization of the type of construction of the motor was detected.



The respective parameter is entered in "S-0-0423, IDN-list of invalid op. data for parameterization level".

Diagnostic Command Messages

Cause	Remedy
A motor without encoder data memory was connected	Parameterize "P-x-4014, Type of construction of motor" correctly or connect a motor with encoder data memory. Note: "x" in parameter number is a wild card for parameter set; e.g. "P-0-4014" for first parameter set.
A motor with encoder data memory was connected, but data stored in memory are incomplete or encoder line resp. encoder is defective	Check whether "P-0-2141, Motor type, encoder memory" contains correct type designation of connected motor. If not, contact our service department. If "P-0-2141, Motor type, encoder memory" cannot be read, replace encoder line or motor encoder

For removing command errors see "Command Errors"

C0285 - Attributes **Display:** C0285
 Ident N°: C0285

10.2.124 C0286 Several motor encoders connected

Allocation	Contained in 02VRS:	«-»	«-»	«-»	
	Contained in 03VRS:	«MPB»	«MPH»	«MPD»	
	Contained in 04VRS:	«MPB»	«MPH»	«MPD»	
	Contained in 05VRS:	«MPB»	«MPH»	«MPD»	
	Contained in 06VRS:	«MPB»	«MPH»	«MPD»	«MPC»
	Contained in 07VRS:	«MPB»	«MPH»	«MPD»	«MPC»
	Contained in 08VRS:	«MPB»	«MPH»	«MPD»	«MPC»
	Supported by supply unit:	«-»			

During the execution of the command "C0200" two motor encoders were detected during the encoder configuration check.

Cause	Remedy
Two encoders were detected; in their data memories a valid and known motor type string is contained in "P-0-2141, Motor type, encoder memory"	Replace one of encoders by encoder without valid motor type string
Encoder connectors of neighboring axes were interchanged	Check axis assignment of encoder connectors and assign to correct axis

For removing command errors see "Command Errors"

C0286 - Attributes **Display:** C0286
 Ident N°: C0286

10.2.125 C0287 Error during initialization of motor data (->S-0-0423)

Allocation	Contained in 02VRS:	«-»	«-»	«-»	
	Contained in 03VRS:	«MPB»	«MPH»	«MPD»	
	Contained in 04VRS:	«MPB»	«MPH»	«MPD»	
	Contained in 05VRS:	«MPB»	«MPH»	«MPD»	
	Contained in 06VRS:	«MPB»	«MPH»	«MPD»	«MPC»
	Contained in 07VRS:	«MPB»	«MPH»	«MPD»	«MPC»
	Contained in 08VRS:	«MPB»	«MPH»	«MPD»	«MPC»
	Supported by supply unit:	«-»			



In the firmware versions 02VRS and 03VRS, the name of the command error is "C0287 Error during initialization of motor data (->S-0-0022)".

Diagnostic Command Messages

02VRS / 03VRS During the execution of the command "S-0-0128, C0200 Communication phase 4 transition check" an error during the initialization of the motor data was detected. The respective parameters are entered in the list "S-0-0022, IDN list of invalid operating data for communication phase 3".

Cause	Remedy
Invalid motor data stored in motor data memory	Replace motor or contact service department for correction of motor data
Synchronous motor with motor encoder data memory (MSK, MHD, MKD, MKE) was connected to controller which so far had controlled motor in open-loop operation	Check whether closed-loop operation required for synchronous motors was set in "P-0-0045, Control word of current controller"; set closed-loop operation, if necessary
Encoder cable defective or bad shielding	Check encoder cable and shielding
Encoder memory or encoder electronics defective	Replace encoder
Hardware defect on control section	Replace control section or entire drive controller



Only Rexroth service engineers or especially trained users are allowed to replace the control section. The replacement of the entire drive controller is described in the Project Planning Manual for the power section.

04VRS During the execution of the command "S-0-0422, C0200 Exit parameterization level procedure command" an error was detected during the initialization of the motor data. The respective parameters are entered in the list "S-0-0423, IDN-list of invalid op. data for parameterization level".

Cause	Remedy
Invalid motor data stored in motor data memory	Replace motor or contact service department for correction of motor data
Synchronous motor with motor encoder data memory (MSK, MHD, MKD, MKE) was connected to controller which so far had controlled motor in open-loop operation	Check whether closed-loop operation required for synchronous motors was set in "P-0-0045, Control word of current controller"; set closed-loop operation, if necessary
Encoder cable defective or bad shielding	Check encoder cable and shielding
Encoder memory or encoder electronics defective	Replace encoder
Hardware defect on control section	Replace control section or entire drive controller



Only Rexroth service engineers or especially trained users are allowed to replace the control section. The replacement of the entire drive controller is described in the Project Planning Manual for the power section.

As of 05VRS During the execution of the command "S-0-0422, C0200 Exit parameterization level procedure command" an error was detected during the initialization of the motor data. The respective parameters are entered in the list "S-0-0423, IDN-list of invalid op. data for parameterization level".

Cause	Remedy
Invalid motor data stored in motor data memory	Replace motor or contact service department for correction of motor data
Encoder cable defective or bad shielding	Check encoder cable and shielding

Diagnostic Command Messages

Cause	Remedy
Encoder memory or encoder electronics defective	Replace encoder
Hardware defect on control section	Replace control section or entire drive controller



Only Rexroth service engineers or especially trained users are allowed to replace the control section. The replacement of the entire drive controller is described in the Project Planning Manual for the power section.

For removing command errors see "Command Errors"

C0287 - Attributes
 Display: C0287
 Ident N°: C0287

10.2.126 C0288 Rotary scaling not allowed

Allocation	Contained in 02VRS:	«-»	«-»	«-»	
	Contained in 03VRS:	«MPB»	«MPH»	«MPD»	
	Contained in 04VRS:	«MPB»	«MPH»	«MPD»	
	Contained in 05VRS:	«MPB»	«MPH»	«MPD»	
	Contained in 06VRS:	«MPB»	«MPH»	«MPD»	«MPC»
	Contained in 07VRS:	«MPB»	«MPH»	«MPD»	«MPC»
	Contained in 08VRS:	«MPB»	«MPH»	«MPD»	«MPC»
	Supported by supply unit:	«-»			

During the execution of the command "C0200" an error was detected with regard to scaling that was set and the selected motor type (e.g. rotary scaling although a linear motor is used). The phase switch to communication phase 4 is prevented.

Cause	Remedy
Although a linear motor is used, rotary scaling was selected in at least one of the following parameters: <ul style="list-style-type: none"> S-0-0044, Velocity data scaling type S-0-0076, Position data scaling type S-0-0086, Torque/force data scaling type S-0-0160, Acceleration data scaling type 	Check and correct respective scaling parameter(s) or use a linear encoder

For removing command errors see "Command Errors"

C0288 - Attributes
 Display: C0288
 Ident N°: C0288

10.2.127 C0289 Error at init. of synchr. motor with reluctance torque

Allocation	Contained in 02VRS:	«-»	«-»	«-»	
	Contained in 03VRS:	«MPB»	«MPH»	«MPD»	
	Contained in 04VRS:	«MPB»	«MPH»	«MPD»	
	Contained in 05VRS:	«MPB»	«MPH»	«MPD»	
	Contained in 06VRS:	«MPB»	«MPH»	«MPD»	«MPC»
	Contained in 07VRS:	«MPB»	«MPH»	«MPD»	«MPC»
	Contained in 08VRS:	«MPB»	«MPH»	«MPD»	«MPC»
	Supported by supply unit:	«-»			

During the execution of the command "C0200" a validation error was detected during the initialization of a synchronous motor with reluctance torque.

Diagnostic Command Messages



The initialization of a synchronous motor with reluctance torque is only run when this has been set in parameter "P-0-4014, Type of construction of motor".

The initialization of a synchronous motor implies the following parameters:

- S-0-0109, Motor peak current
- S-0-0110, Amplifier peak current
- S-0-0111, Motor current at standstill
- P-0-0018, Number of pole pairs/pole pair distance
- P-0-0051, Torque/force constant
- P-0-4002, Charact. of quadrature-axis induct. of motor, inductances
- P-0-4003, Charact. of quadrature-axis inductance of motor, currents
- P-0-4016, Direct-axis inductance of motor
- P-0-4017, Quadrature-axis inductance of motor

Cause	Remedy
Incomplete or invalid entries in parameters for initialization of synchronous motor	Check parameter contents and enter data supplied by motor manufacturer in above parameters. If error is generated in spite of correct data, please contact our service department
Initialization for synchronous motor with reluctance torque was run although synchronous motor without reluctance torque is used	Correct setting in "P-0-4014, Type of construction of motor"

See also Functional Description of firmware "Third-Party Motors at IndraDrive Controllers"

For removing command errors see "Command Errors"

C0289 - Attributes Display: C0289
 Ident N°: C0289

10.2.128 C0290 Error when reading encoder data => measuring encoder

Allocation	Contained in 02VRS:	«-»	«-»	«-»	
	Contained in 03VRS:	«MPB»	«MPH»	«MPD»	
	Contained in 04VRS:	«MPB»	«MPH»	«MPD»	
	Contained in 05VRS:	«MPB»	«MPH»	«MPD»	
	Contained in 06VRS:	«MPB»	«MPH»	«MPD»	«MPC»
	Contained in 07VRS:	«MPB»	«MPH»	«MPD»	«MPC»
	Contained in 08VRS:	«MPB»	«MPH»	«MPD»	«MPC»
	Supported by supply unit:	«-»			

It was impossible to read the encoder data (P-0-1020, Kind of encoder 3, encoder memory"; "P-0-1021, Encoder 3 resolution, encoder memory"; "P-0-1022, Absolute encoder offset 3, encoder memory") correctly from the encoder memory during the initialization of the control section.

Cause	Remedy
Interference caused by incorrect shielding or defective encoder cable	Check encoder cable (incl. shielding) and, if necessary, replace or run it correctly
Encoder defective	Check encoder function and, if necessary, replace encoder

Diagnostic Command Messages

10.2.130 C0292 Measuring encoder unknown

Allocation	Contained in 02VRS:	«-»	«-»	«-»	
	Contained in 03VRS:	«MPB»	«MPH»	«MPD»	
	Contained in 04VRS:	«MPB»	«MPH»	«MPD»	
	Contained in 05VRS:	«MPB»	«MPH»	«MPD»	
	Contained in 06VRS:	«MPB»	«MPH»	«MPD»	«MPC»
	Contained in 07VRS:	«MPB»	«MPH»	«MPD»	«MPC»
	Contained in 08VRS:	«MPB»	«MPH»	«MPD»	«MPC»
	Supported by supply unit:	«-»			

During the execution of the command "C0200" an error with regard to the measuring encoder was detected. The content of "P-0-1020, Kind of encoder 3, encoder memory" is invalid and the measuring encoder therefore is not allowed.

Cause	Remedy
Encoder memory (feedback) is defective	Encoder must be replaced
Kind of motor encoder ("P-0-1020, Kind of encoder 3, encoder memory") is not supported by the software	Check content of "P-0-1020, Kind of encoder 3, encoder memory" and contact our service department
Detected kind of encoder does not match parameterized type of encoder ("P-0-0079, Assignment measuring encoder ->optional slot")	Check "P-0-0079, Assignment measuring encoder ->optional slot" and, if necessary, replace control section by correctly configured control section or replace complete drive controller



Only Rexroth service engineers or especially trained users are allowed to replace the control section. The replacement of the entire drive controller is described in the Project Planning Manual for the power section.

C0292 - Attributes	Display:	C0292
	Ident N°:	C0292

10.2.131 C0293 Modulo value for measuring encoder cannot be displayed

Allocation	Contained in 02VRS:	«-»	«-»	«-»	
	Contained in 03VRS:	«MPB»	«MPH»	«MPD»	
	Contained in 04VRS:	«MPB»	«MPH»	«MPD»	
	Contained in 05VRS:	«MPB»	«MPH»	«MPD»	
	Contained in 06VRS:	«MPB»	«MPH»	«MPD»	«MPC»
	Contained in 07VRS:	«MPB»	«MPH»	«MPD»	«MPC»
	Contained in 08VRS:	«MPB»	«MPH»	«MPD»	«MPC»
	Supported by supply unit:	«-»			

During the execution of command "C0200" an error was detected.

Cause	Remedy
Value parameterized for "P-0-0765, Modulo factor measuring encoder" cannot be displayed internally with gear that was set	Correct content of "P-0-0765, Modulo factor measuring encoder" or measuring gear settings ("P-0-0127, Input revolutions of measuring gear" and "P-0-0128, Output revolutions of measuring gear")
"P-0-0327, Encoder resolution of measuring encoder" incorrectly parameterized	Check and, if necessary, correct content of "P-0-0327, Encoder resolution of measuring encoder"

See also Functional Description of firmware "Scaling"

Diagnostic Command Messages

10.2.134 C0299 Configuration changed. Restart

Allocation	Contained in 02VRS:	«-»	«-»	«-»	
	Contained in 03VRS:	«-»	«-»	«-»	
	Contained in 04VRS:	«MPB»	«MPH»	«MPD»	
	Contained in 05VRS:	«MPB»	«MPH»	«MPD»	
	Contained in 06VRS:	«MPB»	«MPH»	«MPD»	«MPC»
	Contained in 07VRS:	«MPB»	«MPH»	«MPD»	«MPC»
	Contained in 08VRS:	«MPB»	«MPH»	«MPD»	«MPC»
	Supported by supply unit:	«-»			

While command "S-0-0422, C0200 Exit parameterization level procedure command" was executed, the configuration was detected to have been changed without the drive having been rebooted.

Cause	Remedy
"P-0-2003, Selection of functional packages" contains functional package selection not corresponding to active functional package selection (cf. "P-0-2004, Active functional packages")	Switch drive off and on again in order to apply functional package selection of P-0-2003 to P-0-2004
Incorrect functional package selection in "P-0-2003, Selection of functional packages"	Set value in "P-0-2003, Selection of functional packages" to value in "P-0-2004, Active functional packages"
Up to MPx05: Different input channel of master communication was selected in P-0-4088 (bits 14/15) As of MPx06: Different field bus protocol was selected in "P-0-4089.0.1, Master communication: Protocol"	Switch drive off and on again to apply change in P-0-4088 and "P-0-4089.0.1, Master communication: Protocol"

See also Functional Description of firmware "Enabling of Functional Packages".

For removing command errors see "Command Errors"

C0299 - Attributes	Display:	C0299
	Ident N°:	C0299

10.2.135 C0301 Measuring system unavailable

Allocation	Contained in 02VRS:	«MPB»	«MPH»	«MPD»	
	Contained in 03VRS:	«MPB»	«MPH»	«MPD»	
	Contained in 04VRS:	«MPB»	«MPH»	«MPD»	
	Contained in 05VRS:	«MPB»	«MPH»	«MPD»	
	Contained in 06VRS:	«MPB»	«MPH»	«MPD»	«MPC»
	Contained in 07VRS:	«MPB»	«MPH»	«MPD»	«MPC»
	Contained in 08VRS:	«MPB»	«MPH»	«MPD»	«MPC»
	Supported by supply unit:	«-»			

During the execution of the "Set absolute measuring" command (C0300) the measuring system selected by parameter "P-0-0612, Control word for setting absolute measuring" was detected to be unavailable.

Cause	Remedy
Command was activated by mistake	Prevent command from being activated
Measuring system has not been parameterized	Parameterize measuring system

See also Functional Description of firmware "Establishing the Position Data Reference"

C0301 - Attributes Display: C0301
 Ident N°: C0301

10.2.136 C0302 Absolute evaluation of measuring system impossible

Allocation	Contained in 02VRS:	«MPB»	«MPH»	«MPD»	
	Contained in 03VRS:	«MPB»	«MPH»	«MPD»	
	Contained in 04VRS:	«MPB»	«MPH»	«MPD»	
	Contained in 05VRS:	«MPB»	«MPH»	«MPD»	
	Contained in 06VRS:	«MPB»	«MPH»	«MPD»	«MPC»
	Contained in 07VRS:	«MPB»	«MPH»	«MPD»	«MPC»
	Contained in 08VRS:	«MPB»	«MPH»	«MPD»	«MPC»
	Supported by supply unit:	«-»			

During the execution of the command "set absolute measuring"(C0300), it was detected that absolute evaluation of the selected measuring system is impossible.



The command "set absolute measuring" can only be executed, when an absolute measuring system is available (see "S-0-0277, Position feedback 1 type" or "S-0-0115, Position feedback 2 type").

Cause	Remedy
Command was activated by mistake	Prevent command from being activated
Motor encoder or optional measuring system have not been designed as absolute encoders	Equip motor or optional measuring system with absolute encoder function
Selected maximum travel range is too big	Check value in parameter "S-0-0278, Maximum travel range"

See also Functional Description of firmware "Establishing Position Data Reference for Absolute Measuring Systems"

C0302 - Attributes Display: C0302
 Ident N°: C0302

10.2.137 C0303 Absolute encoder offset cannot be saved

Allocation	Contained in 02VRS:	«MPB»	«MPH»	«MPD»	
	Contained in 03VRS:	«MPB»	«MPH»	«MPD»	
	Contained in 04VRS:	«MPB»	«MPH»	«MPD»	
	Contained in 05VRS:	«MPB»	«MPH»	«MPD»	
	Contained in 06VRS:	«MPB»	«MPH»	«MPD»	«MPC»
	Contained in 07VRS:	«MPB»	«MPH»	«MPD»	«MPC»
	Contained in 08VRS:	«MPB»	«MPH»	«MPD»	«MPC»
	Supported by supply unit:	«-»			

When executing the command for setting absolute measuring (C0300) the offset of the encoder zero point with regard to the machine zero point is determined and stored in the data memory of the encoder. It was impossible to store the offset correctly.

Cause	Remedy
Communication between encoder and drive is disturbed	Check encoder cable and repair it, if necessary - or - Replace encoder

Diagnostic Command Messages

C0303 - Attributes **Display:** C0303
Ident N°: C0303

10.2.138 C0401 Switching not allowed

Allocation	Contained in 02VRS:	«MPB»	«MPH»	«MPD»	
	Contained in 03VRS:	«MPB»	«MPH»	«MPD»	
	Contained in 04VRS:	«MPB»	«MPH»	«MPD»	
	Contained in 05VRS:	«MPB»	«MPH»	«MPD»	
	Contained in 06VRS:	«MPB»	«MPH»	«MPD»	«MPC»
	Contained in 07VRS:	«MPB»	«MPH»	«MPD»	«MPC»
	Contained in 08VRS:	«MPB»	«MPH»	«MPD»	«MPC»
	Supported by supply unit:	«HMV»			



In the firmware versions 02VRS and 03VRS, the name of the command error is "C0401 Drive active, switching not allowed".

02VRS / 03VRS When switching to communication phase 2 (C0400) an error was detected.

Cause	Remedy
Command for switching to parameter mode was started by means of parameter "P-0-4023, C0400 Communication phase 2 transition" although drive enable had been activated	Terminate command and switch drive enable off, then command can be started again

As of 04VRS When switching to parameterization level 1 (C0400) an error was detected.

Cause	Remedy
Command "S-0-0420, C0400 Activate parameterization level 1 procedure command" was started although command "S-0-0422, C0200 Exit parameterization level procedure command" had still been active	Terminate command C0400 and wait until command C0200 has been completed. Then you can restart command C0400
Command for switching to parameterization level 1 was started by means of parameter "S-0-0420, C0400 Activate parameterization level 1 procedure command" although drive enable had been activated	Terminate command and switch drive enable off, then command can be started again

C0401 - Attributes **Display:** C0401
Ident N°: C0401

10.2.139 C0403 Switching to CCD phase 2 impossible

Allocation	Contained in 02VRS:	«-»	«-»	«-»	
	Contained in 03VRS:	«-»	«-»	«-»	
	Contained in 04VRS:	«-»	«MPH»	«-»	
	Contained in 05VRS:	«-»	«MPH»	«-»	
	Contained in 06VRS:	«-»	«-»	«-»	«MPC»
	Contained in 07VRS:	«-»	«-»	«-»	«MPC»
	Contained in 08VRS:	«-»	«-»	«-»	«MPC»
	Supported by supply unit:	«-»			

While command "S-0-0420, C0400 Activate parameterization level 1 procedure command" was executed, an error with regard to the CCD slaves (CCD: Cross Communication Drives) occurred.

Diagnostic Command Messages



As of MPx08, P-0-1600, bit 5 can be used to define in the CCD slaves whether the SERCOS phase progression is decoupled from the device switchover. As a result, an error during initialization of the axis does not necessarily cause abortion of the CCD phase progression.



Parameterization level 1 is activated despite incorrect execution of command "S-0-0420, C0400 Activate parameterization level 1 procedure command".

Cause	Remedy
Attempt to bring CCD slaves to CCD phase 2, 30 seconds after start of command "S-0-0420, C0400 Activate parameterization level 1 procedure command", has failed due to communication problem with CCD slaves	Check communication with CCD slaves

See also Functional Description of firmware "Cross Communication (CCD)"

C0403 - Attributes **Display:** C0403
 Ident N°: C0403

10.2.140 C0501 Error clearing only in parameter mode

Allocation	Contained in 02VRS:	«MPB»	«MPH»	«MPD»	
	Contained in 03VRS:	«MPB»	«MPH»	«MPD»	
	Contained in 04VRS:	«MPB»	«MPH»	«MPD»	
	Contained in 05VRS:	«MPB»	«MPH»	«MPD»	
	Contained in 06VRS:	«MPB»	«MPH»	«MPD»	«MPC»
	Contained in 07VRS:	«MPB»	«MPH»	«MPD»	«MPC»
	Contained in 08VRS:	«MPB»	«MPH»	«MPD»	«MPC»
	Supported by supply unit:	«-»			

During the execution of the error clearing command (C0500) an error was detected.

Cause	Remedy
There was an attempt to clear error "F8022 Enc. 1 error: sign. amplitude (can be cleared in ph.2)" in communication phase 4 (operating mode). This is only possible in communication phase 2 (parameterization mode).	Switch drive to communication phase 2 by means of command "P-0-4023, C0400 Communication phase 2 transition" and start error clearing command again.

C0501 - Attributes **Display:** C0501
 Ident N°: C0501

10.2.141 C0601 Homing only possible with drive enable

Allocation	Contained in 02VRS:	«MPB»	«MPH»	«MPD»	
	Contained in 03VRS:	«MPB»	«MPH»	«MPD»	
	Contained in 04VRS:	«MPB»	«MPH»	«MPD»	
	Contained in 05VRS:	«MPB»	«MPH»	«MPD»	
	Contained in 06VRS:	«MPB»	«MPH»	«MPD»	«MPC»
	Contained in 07VRS:	«MPB»	«MPH»	«MPD»	«MPC»
	Contained in 08VRS:	«MPB»	«MPH»	«MPD»	«MPC»
	Supported by supply unit:	«-»			

During the execution of the "Drive-controlled homing procedure" command (C0600) an error was detected.

Diagnostic Command Messages

Cause	Remedy
Command was started without drive enable. This is not allowed.	Enable drive and start command again.

See also Functional Description of firmware "Drive-Controlled Homing"

C0601 - Attributes Display: C0601
 Ident N°: C0601

10.2.142 C0602 Distance home switch - reference mark erroneous

Allocation	Contained in 02VRS:	«MPB»	«MPH»	«MPD»	
	Contained in 03VRS:	«MPB»	«MPH»	«MPD»	
	Contained in 04VRS:	«MPB»	«MPH»	«MPD»	
	Contained in 05VRS:	«MPB»	«MPH»	«MPD»	
	Contained in 06VRS:	«MPB»	«MPH»	«MPD»	«MPC»
	Contained in 07VRS:	«MPB»	«MPH»	«MPD»	«MPC»
	Contained in 08VRS:	«MPB»	«MPH»	«MPD»	«MPC»
	Supported by supply unit:	«-»			

During the execution of the command for drive-controlled homing (C0600) an error was detected.

Cause	Remedy
Evaluation of home switch has been switched on ("S-0-0147, Homing parameter"). Distance between selected home switch edge and reference mark to be evaluated is outside of allowed range.	Read value from parameter "S-0-0298, Reference cam shift" and apply it to parameter "S-0-0299, Home switch offset" - or - Shift reference cam

See also Functional Description of firmware "Establishing Position Data Reference for Relative Measuring Systems"

C0602 - Attributes Display: C0602
 Ident N°: C0602

10.2.143 C0603 Homing impossible with optional encoder

Allocation	Contained in 02VRS:	«-»	«-»	«-»	
	Contained in 03VRS:	«-»	«-»	«-»	
	Contained in 04VRS:	«MPB»	«MPH»	«MPD»	
	Contained in 05VRS:	«MPB»	«MPH»	«MPD»	
	Contained in 06VRS:	«MPB»	«MPH»	«MPD»	«MPC»
	Contained in 07VRS:	«MPB»	«MPH»	«MPD»	«MPC»
	Contained in 08VRS:	«MPB»	«MPH»	«MPD»	«MPC»
	Supported by supply unit:	«-»			

During the execution of the command "C0600 Drive-controlled homing procedure command" an error occurred.

Cause	Remedy
Optional encoder has been parameterized as homing encoder in "S-0-0147, Homing parameter" although optional encoder does not exist	Parameterize motor encoder as homing encoder in "S-0-0147, Homing parameter"
Optional encoder has not been activated	Activate optional encoder in "P-0-0075, Encoder type 2 (optional encoder)"

C0603 - Attributes Display: C0603
 Ident N°: C0603

10.2.144 C0604 Homing impossible with absolute encoder

Allocation	Contained in 02VRS:	«MPB»	«MPH»	«MPD»	
	Contained in 03VRS:	«MPB»	«MPH»	«MPD»	
	Contained in 04VRS:	«MPB»	«MPH»	«MPD»	
	Contained in 05VRS:	«MPB»	«MPH»	«MPD»	
	Contained in 06VRS:	«MPB»	«MPH»	«MPD»	«MPC»
	Contained in 07VRS:	«MPB»	«MPH»	«MPD»	«MPC»
	Contained in 08VRS:	«MPB»	«MPH»	«MPD»	«MPC»
	Supported by supply unit:	«-»			

During the execution of the command for drive-controlled homing (C0600) an error was detected.

Cause	Remedy
By encoder selection in "S-0-0147, Homing parameter" an absolute measuring system was selected. Command for drive-controlled homing can only be executed if command "P-0-0012, C0300 Command Set absolute measuring" had been activated before.	First activate command "P-0-0012, C0300 Command Set absolute measuring" and then start command "S-0-0148, C0600 Drive-controlled homing procedure command"; by doing this, absolute position data reference is established.

C0604 - Attributes Display: C0604
 Ident N°: C0604

10.2.145 C0606 Reference mark not detected

Allocation	Contained in 02VRS:	«MPB»	«MPH»	«MPD»	
	Contained in 03VRS:	«MPB»	«MPH»	«MPD»	
	Contained in 04VRS:	«MPB»	«MPH»	«MPD»	
	Contained in 05VRS:	«MPB»	«MPH»	«MPD»	
	Contained in 06VRS:	«MPB»	«MPH»	«MPD»	«MPC»
	Contained in 07VRS:	«MPB»	«MPH»	«MPD»	«MPC»
	Contained in 08VRS:	«MPB»	«MPH»	«MPD»	«MPC»
	Supported by supply unit:	«-»			

During the execution of the command for drive-controlled homing (C0600) an error with regard to the reference marks of the encoder was detected.

If the reference marks of the relative encoder to be homed (selected in "S-0-0147, Homing parameter") occur cyclically over the travel range, the position difference of the reference marks detected by the controller is monitored. This requires the correct setting for "P-0-0153, Optimum distance home switch-reference mark".

Cause	Remedy
Reference marks do not occur in expected position difference	Check measuring system to be homed and corresponding wiring - or - Check and, if necessary, correct setting of "P-0-0153, Optimum distance home switch-reference mark"
Value set in "P-0-0153, Optimum distance home switch-reference mark" does not match encoder that is used	Correct setting of "P-0-0153, Optimum distance home switch-reference mark"

See also Functional Description of firmware "Establishing Position Data Reference for Relative Measuring Systems"

C0606 - Attributes Display: C0606
 Ident N°: C0606

Diagnostic Command Messages

10.2.146 C0607 Reference cam input not assigned

Allocation	Contained in 02VRS:	«MPB»	«MPH»	«MPD»	
	Contained in 03VRS:	«MPB»	«MPH»	«MPD»	
	Contained in 04VRS:	«MPB»	«MPH»	«MPD»	
	Contained in 05VRS:	«MPB»	«MPH»	«MPD»	
	Contained in 06VRS:	«MPB»	«MPH»	«MPD»	«MPC»
	Contained in 07VRS:	«MPB»	«MPH»	«MPD»	«MPC»
	Contained in 08VRS:	«MPB»	«MPH»	«MPD»	«MPC»
	Supported by supply unit:	«-»			

During the execution of the "Drive-controlled homing procedure" command (C0600) an error was detected.

Cause	Remedy
Home switch hasn't been assigned to any digital input	Assign home switch ("S-0-0400, Home switch") to a digital input via parameter "P-0-0300, Digital I/Os, assignment list"

C0607 - Attributes Display: C0607
 Ident N°: C0607

10.2.147 C0608 Pos. stop a. HW lim. switch not allowed f. modulo axes

Allocation	Contained in 02VRS:	«-»	«-»	«-»	
	Contained in 03VRS:	«MPB»	«MPH»	«MPD»	
	Contained in 04VRS:	«MPB»	«MPH»	«MPD»	
	Contained in 05VRS:	«MPB»	«MPH»	«MPD»	
	Contained in 06VRS:	«MPB»	«MPH»	«MPD»	«MPC»
	Contained in 07VRS:	«MPB»	«MPH»	«MPD»	«MPC»
	Contained in 08VRS:	«MPB»	«MPH»	«MPD»	«MPC»
	Supported by supply unit:	«-»			

During the execution of the command for drive-controlled homing (C0600) an error was detected.

Cause	Remedy
Drive-controlled homing at positive stop or travel range limit switch with modulo axes isn't a useful combination and therefore not allowed!	Modify control information for homing in "S-0-0147, Homing parameter" in a useful way

C0608 - Attributes Display: C0608
 Ident N°: C0608

10.2.148 C0609 Different travel directions parameterized

Allocation	Contained in 02VRS:	«-»	«-»	«-»	
	Contained in 03VRS:	«MPB»	«MPH»	«MPD»	
	Contained in 04VRS:	«MPB»	«MPH»	«MPD»	
	Contained in 05VRS:	«MPB»	«MPH»	«MPD»	
	Contained in 06VRS:	«MPB»	«MPH»	«MPD»	«MPC»
	Contained in 07VRS:	«MPB»	«MPH»	«MPD»	«MPC»
	Contained in 08VRS:	«MPB»	«MPH»	«MPD»	«MPC»
	Supported by supply unit:	«-»			

When, in the case of modulo scaling, the homing direction parameterized in "S-0-0147, Homing parameter" and the positioning direction set for spindle positioning in "S-0-0393, Command value mode" do not match, the command error C0609 is output during the execution of the command for drive-controlled homing (C0600).

Diagnostic Command Messages

Cause	Remedy
Travel directions for homing and positioning were differently parameterized	Parameterize travel directions in "S-0-0147, Homing parameter" and "S-0-0393, Command value mode" in such a way that they match

C0609 - Attributes **Display:** C0609
 Ident N°: C0609

10.2.149 C0610 Absolute encoder offset could not be saved

Allocation	Contained in 02VRS:	«-»	«-»	«-»	
	Contained in 03VRS:	«-»	«-»	«-»	
	Contained in 04VRS:	«MPB»	«MPH»	«MPD»	
	Contained in 05VRS:	«MPB»	«MPH»	«MPD»	
	Contained in 06VRS:	«MPB»	«MPH»	«MPD»	«MPC»
	Contained in 07VRS:	«MPB»	«MPH»	«MPD»	«MPC»
	Contained in 08VRS:	«MPB»	«MPH»	«MPD»	«MPC»
	Supported by supply unit:	«-»			

During the execution of the command for drive-controlled homing (C0600) an error occurred: In the case of a measuring system with feedback data memory evaluated in absolute form, the determined absolute encoder offset could not be saved in the feedback data memory.

Cause	Remedy
Cable defective	Check connection between encoder and drive controller
Feedback data memory defective	Replace encoder

C0610 - Attributes **Display:** C0610
 Ident N°: C0610

10.2.150 C0702 Default parameters not available

Allocation	Contained in 02VRS:	«MPB»	«MPH»	«MPD»	
	Contained in 03VRS:	«MPB»	«MPH»	«MPD»	
	Contained in 04VRS:	«MPB»	«MPH»	«MPD»	
	Contained in 05VRS:	«MPB»	«MPH»	«MPD»	
	Contained in 06VRS:	«MPB»	«MPH»	«MPD»	«MPC»
	Contained in 07VRS:	«MPB»	«MPH»	«MPD»	«MPC»
	Contained in 08VRS:	«MPB»	«MPH»	«MPD»	«MPC»
	Supported by supply unit:	«-»			

While command "C0700 Load defaults proced. command (motor-spec. controller val.)" was executed, an error occurred.

Cause	Remedy
Control loops of motors with motor encoder data memory are adjusted to connected digital drive by activating controller parameters stored in it. Message C0702 on display of drive controller signals that no data memory is available at connected motor.	Data sheets of Rexroth motors are made available by the service department. Enter controller parameters.

See also Functional Description of firmware "Loading, Storing and Saving Parameters"

See also Functional Description of firmware "Rexroth Housing Motors with Encoder Data Memory"

Diagnostic Command Messages

C0702 - Attributes **Display:** C0702
Ident N°: C0702

10.2.151 C0703 Default parameters invalid

Allocation	Contained in 02VRS:	«MPB»	«MPH»	«MPD»	
	Contained in 03VRS:	«MPB»	«MPH»	«MPD»	
	Contained in 04VRS:	«MPB»	«MPH»	«MPD»	
	Contained in 05VRS:	«MPB»	«MPH»	«MPD»	
	Contained in 06VRS:	«MPB»	«MPH»	«MPD»	«MPC»
	Contained in 07VRS:	«MPB»	«MPH»	«MPD»	«MPC»
	Contained in 08VRS:	«MPB»	«MPH»	«MPD»	«MPC»
	Supported by supply unit:	«-»			

While command "C0700 Load defaults proced. command (motor-spec. controller val.)" was executed, an error occurred.

Cause	Remedy
Default parameters are read from motor encoder data memory. At least one of these parameters is invalid.	Check connection to motor encoder. Replace motor, if necessary.

See also Functional Description of firmware "Loading, Storing and Saving Parameters"

See also Functional Description of firmware "Rexroth Housing Motors with Encoder Data Memory"

C0703 - Attributes **Display:** C0703
Ident N°: C0703

10.2.152 C0704 Parameters not copyable

Allocation	Contained in 02VRS:	«MPB»	«MPH»	«MPD»	
	Contained in 03VRS:	«MPB»	«MPH»	«MPD»	
	Contained in 04VRS:	«MPB»	«MPH»	«MPD»	
	Contained in 05VRS:	«MPB»	«MPH»	«MPD»	
	Contained in 06VRS:	«MPB»	«MPH»	«MPD»	«MPC»
	Contained in 07VRS:	«MPB»	«MPH»	«MPD»	«MPC»
	Contained in 08VRS:	«MPB»	«MPH»	«MPD»	«MPC»
	Supported by supply unit:	«-»			

While command "C0700 Load defaults proced. command (motor-spec. controller val.)" was executed, an error occurred.

Cause	Remedy
It was impossible to load default values for motor-specific control loop parameters, available in encoder memory, to associated parameters. Firmware version is incompatible with motor or motor encoder	Load appropriate firmware version to controller; observe motor type and motor encoder type
Performance and switching frequency setting do not match	Correct performance setting in "P-0-0556, Control word of axis controller" and switching frequency setting in "P-0-0001, Switching frequency of the power output stage"

See also Functional Description of firmware "Loading, Storing and Saving Parameters"

See also Functional Description of firmware "Rexroth Housing Motors with Encoder Data Memory"

Diagnostic Command Messages

10.2.155 C0723 Safety command for load defaults procedure incorrect

Allocation	Contained in 02VRS:	«MPB»	«MPH»	«MPD»	
	Contained in 03VRS:	«MPB»	«MPH»	«MPD»	
	Contained in 04VRS:	«MPB»	«MPH»	«MPD»	
	Contained in 05VRS:	«MPB»	«MPH»	«MPD»	
	Contained in 06VRS:	«MPB»	«MPH»	«MPD»	«MPC»
	Contained in 07VRS:	«MPB»	«MPH»	«MPD»	«MPC»
	Contained in 08VRS:	«MPB»	«MPH»	«MPD»	«MPC»
	Supported by supply unit:	«-»			

Command "C0720 Load defaults procedure command (safety technology)" causes the safety parameters of channel 1 to be set to default values and an internal command to be started to ensure that channel 2 accepts the default values. The safety technology is deactivated by the command because valid safety parameters are no longer available. The safety technology is in its condition as supplied.

Cause	Remedy
Internal command for channel 2 was incorrectly executed	Clear command "C0720 Load defaults procedure command (safety technology)" and restart. If error is signaled again, reset optional safety technology module (switch control voltage off and on again)
Channel 2 executes a second internal command which may not be interrupted	Complete internal command that is still running
Hardware defect on optional safety technology module	Restart command "C0720 Load defaults procedure command (safety technology)". If command error occurs repeatedly, replace control section or entire drive controller



Only Rexroth service engineers or especially trained users are allowed to replace the control section. The replacement of the entire drive controller is described in the Project Planning Manual for the power section.

C0723 - Attributes	Display:	C0723
	Ident N°:	C0723

10.2.156 C0724 Timeout of safety command for load defaults procedure

Allocation	Contained in 02VRS:	«MPB»	«MPH»	«MPD»	
	Contained in 03VRS:	«MPB»	«MPH»	«MPD»	
	Contained in 04VRS:	«MPB»	«MPH»	«MPD»	
	Contained in 05VRS:	«MPB»	«MPH»	«MPD»	
	Contained in 06VRS:	«MPB»	«MPH»	«MPD»	«MPC»
	Contained in 07VRS:	«MPB»	«MPH»	«MPD»	«MPC»
	Contained in 08VRS:	«MPB»	«MPH»	«MPD»	«MPC»
	Supported by supply unit:	«-»			

Command "C0720 Load defaults procedure command (safety technology)" includes an internal command that is started for safety technology channel 2. The internal command was aborted with timeout.

Diagnostic Command Messages

10.2.158 C0752 Locked with password

Allocation	Contained in 02VRS:	«MPB»	«MPH»	«MPD»	
	Contained in 03VRS:	«MPB»	«MPH»	«MPD»	
	Contained in 04VRS:	«MPB»	«MPH»	«MPD»	
	Contained in 05VRS:	«MPB»	«MPH»	«MPD»	
	Contained in 06VRS:	«MPB»	«MPH»	«MPD»	«MPC»
	Contained in 07VRS:	«MPB»	«MPH»	«MPD»	«MPC»
	Contained in 08VRS:	«MPB»	«MPH»	«MPD»	«MPC»
	Supported by supply unit:	«-»			

While command "C0750 Load defaults procedure command (factory settings)" was executed, an error occurred.

Cause	Remedy
Drive parameters were write-protected by means of parameter "S-0-0267, Password". Diagnostic message C0752 signals that command "C0750 Load defaults procedure command (factory settings)" was started without deactivating customer password beforehand.	Deactivate write protection by entering password. Then re-start command.

See also Functional Description of firmware "Using a Password"

C0752 - Attributes	Display:	C0752
	Ident N°:	C0752

10.2.159 C0799 An invalid index was set

Allocation	Contained in 02VRS:	«MPB»	«MPH»	«MPD»	
	Contained in 03VRS:	«MPB»	«MPH»	«MPD»	
	Contained in 04VRS:	«MPB»	«MPH»	«MPD»	
	Contained in 05VRS:	«MPB»	«MPH»	«MPD»	
	Contained in 06VRS:	«MPB»	«MPH»	«MPD»	«MPC»
	Contained in 07VRS:	«MPB»	«MPH»	«MPD»	«MPC»
	Contained in 08VRS:	«MPB»	«MPH»	«MPD»	«MPC»
	Supported by supply unit:	«-»			

At the time command "C0700 Load defaults proced. command (motor-spec. controller val.)" was started, no valid value had been entered in "P-0-4090, Configuration for loading default values".



"P-0-4090, Configuration for loading default values" can be used to set the function of command "C0700 Load defaults proced. command (motor-spec. controller val.)".

After the command was cleared, the value in "P-0-4090, Configuration for loading default values" is automatically set to "0" again.

C0799 - Attributes	Display:	C0799
	Ident N°:	C0799

10.2.160 C0851 Parameter default value incorrect (-> S-0-0021)

Allocation	Contained in 02VRS:	«-»	«-»	«-»	
	Contained in 03VRS:	«-»	«-»	«-»	
	Contained in 04VRS:	«-»	«-»	«-»	
	Contained in 05VRS:	«-»	«-»	«-»	
	Contained in 06VRS:	«-»	«-»	«-»	«-»
	Contained in 07VRS:	«-»	«-»	«-»	«-»
	Contained in 08VRS:	«-»	«-»	«-»	«-»
	Supported by supply unit:	«HMV»			



This command error can only occur as a result of the "C0800 Load basic parameters command" that can only be used by the manufacturer!

C0851 - Attributes Display: C0851
 Ident N°:

10.2.161 C0852 Locked with password

Allocation	Contained in 02VRS:	«-»	«-»	«-»	
	Contained in 03VRS:	«-»	«-»	«-»	
	Contained in 04VRS:	«-»	«-»	«-»	
	Contained in 05VRS:	«-»	«-»	«-»	
	Contained in 06VRS:	«-»	«-»	«-»	«-»
	Contained in 07VRS:	«-»	«-»	«-»	«-»
	Contained in 08VRS:	«-»	«-»	«-»	«-»
	Supported by supply unit:	«HMV»			



This command error can only occur as a result of the "C0800 Load basic parameters command" that can only be used by the manufacturer!

C0852 - Attributes Display: C0852
 Ident N°:

10.2.162 C0902 Spindle positioning requires drive enable

Allocation	Contained in 02VRS:	«MPB»	«MPH»	«-»	
	Contained in 03VRS:	«MPB»	«MPH»	«MPD»	
	Contained in 04VRS:	«MPB»	«MPH»	«MPD»	
	Contained in 05VRS:	«MPB»	«MPH»	«MPD»	
	Contained in 06VRS:	«MPB»	«MPH»	«MPD»	«MPC»
	Contained in 07VRS:	«MPB»	«MPH»	«MPD»	«MPC»
	Contained in 08VRS:	«MPB»	«MPH»	«MPD»	«MPC»
	Supported by supply unit:	«-»			

During the execution of the command for spindle positioning (C0900) an error was detected.

Cause	Remedy
At start of "S-0-0152, C0900 Position spindle command", drive was not yet in drive enable	Set drive enable before starting command

C0902 - Attributes Display: C0902
 Ident N°: C0902

Diagnostic Command Messages

10.2.163 C0903 Error during initialization

Allocation	Contained in 02VRS:	«MPB»	«MPH»	«-»	
	Contained in 03VRS:	«MPB»	«MPH»	«MPD»	
	Contained in 04VRS:	«MPB»	«MPH»	«MPD»	
	Contained in 05VRS:	«MPB»	«MPH»	«MPD»	
	Contained in 06VRS:	«MPB»	«MPH»	«MPD»	«MPC»
	Contained in 07VRS:	«MPB»	«MPH»	«MPD»	«MPC»
	Contained in 08VRS:	«MPB»	«MPH»	«MPD»	«MPC»
	Supported by supply unit:	«-»			

While the command for spindle positioning (C0900) was executed, an error was detected.

Cause	Remedy
When "S-0-0152, C0900 Position spindle command" was started, respective encoder had not yet been initialized (homed)	<p>For incremental measuring systems, check whether "S-0-0400, Home switch" was assigned to a digital input. Assignment, connection and function of home switch must have been realized (only when home switch is evaluated)!</p> <p>For absolute measuring systems, check whether drive is in reference. If this is not the case, establish absolute position data reference, e.g., by "P-0-0012, C0300 Set absolute position procedure command" (as of MPx07: "S-0-0447, Set absolute position procedure command")</p>

C0903 - Attributes Display: C0903
 Ident N°: C0903

10.2.164 C0906 Error during search for zero pulse

Allocation	Contained in 02VRS:	«MPB»	«MPH»	«-»	
	Contained in 03VRS:	«MPB»	«MPH»	«MPD»	
	Contained in 04VRS:	«MPB»	«MPH»	«MPD»	
	Contained in 05VRS:	«MPB»	«MPH»	«MPD»	
	Contained in 06VRS:	«MPB»	«MPH»	«MPD»	«MPC»
	Contained in 07VRS:	«MPB»	«MPH»	«MPD»	«MPC»
	Contained in 08VRS:	«MPB»	«MPH»	«MPD»	«MPC»
	Supported by supply unit:	«-»			

During the execution of the command for spindle positioning (C0900) an error was detected.

Cause	Remedy
Homing procedure integrated in spindle positioning was not executed successfully. Encoder zero mark was not found or it was impossible to assign it correctly.	<p>Check parameterization of spindle positioning and of drive-controlled homing procedure, especially encoder and home switch combination used.</p> <p>- or -</p> <p>Check encoder parameterization.</p> <p>- or -</p> <p>Check distance zero pulse - home switch.</p> <p>- or -</p> <p>Carry out drive-controlled homing in order to check homing procedure.</p>

Diagnostic Command Messages

Cause	Remedy
Drive controller is not in phase 4 (ready for operation, display: bb ; with sine-wave and saturation method, display: Ab); the command "P-0-0524, C1200 Commutation offset setting command" can only be executed in phase 4.	Switch drive controller to phase 4 and then execute command "P-0-0524, C1200 Commutation offset setting command" again.

C1209 - Attributes Display: C1209
 Ident N°: C1209

10.2.168 C1211 Commutation offset could not be determined.

Allocation	Contained in 02VRS:	«MPB»	«MPH»	«MPD»	
	Contained in 03VRS:	«MPB»	«MPH»	«MPD»	
	Contained in 04VRS:	«MPB»	«MPH»	«MPD»	
	Contained in 05VRS:	«MPB»	«MPH»	«MPD»	
	Contained in 06VRS:	«MPB»	«MPH»	«MPD»	«MPC»
	Contained in 07VRS:	«MPB»	«MPH»	«MPD»	«MPC»
	Contained in 08VRS:	«MPB»	«MPH»	«MPD»	«MPC»
	Supported by supply unit:	«-»			

An error has occurred during the execution of the command "P-0-0524, C1200 Commutation offset setting command" (in this case: sine-wave method).



Simultaneously output Fxxxx error messages allow more precise diagnosis.

See also Functional Description of firmware "Commutation Setting"

C1211 - Attributes Display: C1211
 Ident N°: C1211

10.2.169 C1212 Motion range exceeded during commutation

Allocation	Contained in 02VRS:	«-»	«-»	«-»	
	Contained in 03VRS:	«MPB»	«MPH»	«MPD»	
	Contained in 04VRS:	«MPB»	«MPH»	«MPD»	
	Contained in 05VRS:	«MPB»	«MPH»	«MPD»	
	Contained in 06VRS:	«MPB»	«MPH»	«MPD»	«MPC»
	Contained in 07VRS:	«MPB»	«MPH»	«MPD»	«MPC»
	Contained in 08VRS:	«MPB»	«MPH»	«MPD»	«MPC»
	Supported by supply unit:	«-»			

The axis left the allowed actual position value range while commutation settings were made.

Cause	Remedy
Command was started while axis was still moving	Wait until axis has come to standstill and restart command
Axis was moved by mechanical force	Exclude influence of mechanical force
Parameter values for "P-0-0506, Amplitude for angle acquisition" and "P-0-0507, Test frequency for angle acquisition" are too high. Possibly, mechanical axis conditions, such as friction and load due to weight, have changed	Reduce parameter values for "P-0-0506, Amplitude for angle acquisition" and "P-0-0507, Test frequency for angle acquisition". They can also be set to default values of 25% for "P-0-0506, Amplitude for angle acquisition" and 500 Hz for "P-0-0507, Test frequency for angle acquisition".

See also Functional Description of firmware "Commutation Setting".

Diagnostic Command Messages

10.2.172 C1216 Commutation determination not selected

Allocation	Contained in 02VRS:	«MPB»	«MPH»	«MPD»	
	Contained in 03VRS:	«MPB»	«MPH»	«MPD»	
	Contained in 04VRS:	«MPB»	«MPH»	«MPD»	
	Contained in 05VRS:	«MPB»	«MPH»	«MPD»	
	Contained in 06VRS:	«MPB»	«MPH»	«MPD»	«MPC»
	Contained in 07VRS:	«MPB»	«MPH»	«MPD»	«MPC»
	Contained in 08VRS:	«MPB»	«MPH»	«MPD»	«MPC»
	Supported by supply unit:	«-»			

During the execution of the command for commutation offset determination (C1200) an error was detected.

Cause	Remedy
There wasn't any mode for commutation determination selected	Set a mode for commutation determination in parameter "P-0-0522, Commutation setting control word"

C1216 - Attributes Display: C1216
 Ident N°: C1216

10.2.173 C1217 Setting only possible in 'Ab'

Allocation	Contained in 02VRS:	«MPB»	«MPH»	«MPD»	
	Contained in 03VRS:	«MPB»	«MPH»	«MPD»	
	Contained in 04VRS:	«MPB»	«MPH»	«MPD»	
	Contained in 05VRS:	«MPB»	«MPH»	«MPD»	
	Contained in 06VRS:	«MPB»	«MPH»	«MPD»	«MPC»
	Contained in 07VRS:	«MPB»	«MPH»	«MPD»	«MPC»
	Contained in 08VRS:	«MPB»	«MPH»	«MPD»	«MPC»
	Supported by supply unit:	«-»			

During the execution of the command for commutation offset determination (C1200) an error was detected.

Cause	Remedy
Drive was not ready at start of command, display did not read "Ab"	<ol style="list-style-type: none"> 1. Switch drive to communication phase 4, if there isn't any error present, display reads "bb" ("betriebsbereit" = ready for operation) 2. Switch power on, drive goes to operating mode, display reads "Ab" ("Antrieb bereit" = drive ready) 3. Now start command C1200

C1217 - Attributes Display: C1217
 Ident N°: C1217

10.2.174 C1218 Automatic commutation: Current too low

Allocation	Contained in 02VRS:	«MPB»	«MPH»	«MPD»	
	Contained in 03VRS:	«MPB»	«MPH»	«MPD»	
	Contained in 04VRS:	«MPB»	«MPH»	«MPD»	
	Contained in 05VRS:	«MPB»	«MPH»	«MPD»	
	Contained in 06VRS:	«MPB»	«MPH»	«MPD»	«MPC»
	Contained in 07VRS:	«MPB»	«MPH»	«MPD»	«MPC»
	Contained in 08VRS:	«MPB»	«MPH»	«MPD»	«MPC»
	Supported by supply unit:	«-»			

Diagnostic Command Messages

10.2.176 C1220 Automatic commutation: Timeout

Allocation	Contained in 02VRS:	«MPB»	«MPH»	«MPD»	
	Contained in 03VRS:	«MPB»	«MPH»	«MPD»	
	Contained in 04VRS:	«MPB»	«MPH»	«MPD»	
	Contained in 05VRS:	«MPB»	«MPH»	«MPD»	
	Contained in 06VRS:	«MPB»	«MPH»	«MPD»	«MPC»
	Contained in 07VRS:	«MPB»	«MPH»	«MPD»	«MPC»
	Contained in 08VRS:	«MPB»	«MPH»	«MPD»	«MPC»
	Supported by supply unit:	«-»			

During the execution of the command for commutation offset determination (C1200) an error was detected.

Cause	Remedy
An error occurred in signal generator	Switch drive off and on again. If error continues to be signaled, contact our service department

C1220 - Attributes **Display:** C1220
Ident N°: C1220

10.2.177 C1221 Automatic commutation: Iteration without result

Allocation	Contained in 02VRS:	«MPB»	«MPH»	«MPD»	
	Contained in 03VRS:	«MPB»	«MPH»	«MPD»	
	Contained in 04VRS:	«MPB»	«MPH»	«MPD»	
	Contained in 05VRS:	«MPB»	«MPH»	«MPD»	
	Contained in 06VRS:	«MPB»	«MPH»	«MPD»	«MPC»
	Contained in 07VRS:	«MPB»	«MPH»	«MPD»	«MPC»
	Contained in 08VRS:	«MPB»	«MPH»	«MPD»	«MPC»
	Supported by supply unit:	«-»			

The commutation offset determination ("P-0-0524, C1200 Commutation offset setting command") was unsuccessful. It was impossible to find appropriate values for "P-0-0506, Amplitude for angle acquisition" and "P-0-0507, Test frequency for angle acquisition" with which it would have been possible to obtain sufficient magnetic saturation effects in the motor. It was therefore impossible to determine a functioning value for the commutation offset.

Cause	Remedy
Type current of controller too low	Use controller that can supply motor with sufficiently high current (for Rexroth kit motors, required minimum current for magnetic saturation effects is approx. 2.0...2.5-fold continuous current at standstill). If without success, check whether sine-wave method can be used for commutation offset setting
Test current generated in motor is too low	Manually increase value of "P-0-0506, Amplitude for angle acquisition" or reduce value of "P-0-0507, Test frequency for angle acquisition" so that higher test current is generated. If without success, check whether sine-wave method can be used for commutation offset setting

See also Functional Description of firmware "Commutation Setting"

C1221 - Attributes **Display:** C1221
Ident N°: C1221

Diagnostic Command Messages

10.2.180 C1301 Class 1 diagnostics error at command start

Allocation	Contained in 02VRS:	«MPB»	«MPH»	«MPD»	
	Contained in 03VRS:	«MPB»	«MPH»	«MPD»	
	Contained in 04VRS:	«MPB»	«MPH»	«MPD»	
	Contained in 05VRS:	«MPB»	«MPH»	«MPD»	
	Contained in 06VRS:	«MPB»	«MPH»	«MPD»	«MPC»
	Contained in 07VRS:	«MPB»	«MPH»	«MPD»	«MPC»
	Contained in 08VRS:	«MPB»	«MPH»	«MPD»	«MPC»
	Supported by supply unit:	«-»			

The command "S-0-0149, C1300 Positive stop drive procedure command" cannot be carried out as a class 1 diagnostics error has occurred.

See also Functional Description of firmware "Positive Stop Drive Procedure"

C1301 - Attributes	Display:	C1301
	Ident N°:	C1301

10.2.181 C1402 Faulty reference mark signal

Allocation	Contained in 02VRS:	«MPB»	«MPH»	«MPD»	
	Contained in 03VRS:	«MPB»	«MPH»	«MPD»	
	Contained in 04VRS:	«MPB»	«MPH»	«MPD»	
	Contained in 05VRS:	«MPB»	«MPH»	«MPD»	
	Contained in 06VRS:	«MPB»	«MPH»	«MPD»	«MPC»
	Contained in 07VRS:	«MPB»	«MPH»	«MPD»	«MPC»
	Contained in 08VRS:	«MPB»	«MPH»	«MPD»	«MPC»
	Supported by supply unit:	«-»			

During the execution of command "P-0-0014, C1400 Command Get marker position" the reference mark signal is checked for its allowed signal width and the assignment to the track signals. If the signal is outside of the allowed specification or disturbed, this error is generated.

Cause	Remedy
Encoder sensor not correctly mounted	Correct mounting of encoder sensor
Reference mark signal disturbed	Check / correct wiring and shielding of reference mark signal

For removing command errors see "Command Errors"

C1402 - Attributes	Display:	C1402
	Ident N°:	C1402

10.2.182 C1701 Measuring wheel mode not possible

Allocation	Contained in 02VRS:	«MPB»	«MPH»	«MPD»	
	Contained in 03VRS:	«MPB»	«MPH»	«MPD»	
	Contained in 04VRS:	«-»	«-»	«-»	
	Contained in 05VRS:	«-»	«-»	«-»	
	Contained in 06VRS:	«-»	«-»	«-»	«-»
	Contained in 07VRS:	«-»	«-»	«-»	«-»
	Contained in 08VRS:	«-»	«-»	«-»	«-»
	Supported by supply unit:	«-»			

The "P-0-0240, C1700 Command measuring wheel mode" cannot be executed.

Diagnostic Command Messages

Cause	Remedy
There aren't two encoders available	Connect measuring wheel encoder

C1701 - Attributes Display: C1701
 Ident N°: C1701

10.2.183 C1801 Start requires drive enable

Allocation	Contained in 02VRS:	«MPB»	«MPH»	«MPD»	
	Contained in 03VRS:	«MPB»	«MPH»	«MPD»	
	Contained in 04VRS:	«MPB»	«MPH»	«MPD»	
	Contained in 05VRS:	«MPB»	«MPH»	«MPD»	
	Contained in 06VRS:	«MPB»	«MPH»	«MPD»	«MPC»
	Contained in 07VRS:	«MPB»	«MPH»	«MPD»	«MPC»
	Contained in 08VRS:	«MPB»	«MPH»	«MPD»	«MPC»
	Supported by supply unit:	«-»			

In order to make sure that the drive is in control when the command "P-0-0162, C1800 Command Automatic control loop adjust" is started, this is queried at the start of the command.

Cause	Remedy
Drive enable not set at start of command	Set drive enable and restart command "P-0-0162, C1800 Command Automatic control loop adjust"

See also Functional Description of firmware "Automatic Setting of Axis Control"

C1801 - Attributes Display: C1801
 Ident N°: C1801

10.2.184 C1802 Motor feedback data not valid

Allocation	Contained in 02VRS:	«MPB»	«MPH»	«MPD»	
	Contained in 03VRS:	«MPB»	«MPH»	«MPD»	
	Contained in 04VRS:	«MPB»	«MPH»	«MPD»	
	Contained in 05VRS:	«MPB»	«MPH»	«MPD»	
	Contained in 06VRS:	«MPB»	«MPH»	«MPD»	«MPC»
	Contained in 07VRS:	«MPB»	«MPH»	«MPD»	«MPC»
	Contained in 08VRS:	«MPB»	«MPH»	«MPD»	«MPC»
	Supported by supply unit:	«-»			

At the beginning of the automatic control loop setting ("P-0-0162, C1800 Command Automatic control loop adjust"), the parameters

- "P-0-0051, Torque/force constant",
- "P-0-0018, Number of pole pairs/pole pair distance" and
- "S-0-0110, Amplifier peak current"

are read from the memory in motor encoder or power section.

Diagnostic Command Messages

Cause	Remedy
One of above-mentioned parameters has a value equal to or less than zero (<= 0) which would cause incorrect calculation of controller parameters	<p>For Rexroth motors with encoder data memory: Service staff writes stored motor parameters or replacement of motor</p> <p>For Rexroth motors without encoder data memory and third-party motors: User writes correct values to motor parameters</p> <p>When device type current is incorrect (S-0-0110): Service staff writes parameter stored in power section or replacement of device</p>

See also Functional Description of firmware "Automatic Setting of Axis Control"

C1802 - Attributes Display: C1802
 Ident N°: C1802

10.2.185 C1803 Inertia detection failed

Allocation	Contained in 02VRS:	«MPB»	«MPH»	«MPD»	
	Contained in 03VRS:	«MPB»	«MPH»	«MPD»	
	Contained in 04VRS:	«MPB»	«MPH»	«MPD»	
	Contained in 05VRS:	«MPB»	«MPH»	«MPD»	
	Contained in 06VRS:	«MPB»	«MPH»	«MPD»	«MPC»
	Contained in 07VRS:	«MPB»	«MPH»	«MPD»	«MPC»
	Contained in 08VRS:	«MPB»	«MPH»	«MPD»	«MPC»
	Supported by supply unit:	«-»			

Automatic control loop setting was aborted; mass moment of inertia (sum of rotor moment of inertia and load moment of inertia) could not be determined



In MPx05V08 and below, the mass moment of inertia had to be determined by evaluating acceleration and deceleration processes.

In MPx05V10 and above, parameter "P-0-0165, Drive optimization, control word" could be used to parameterize whether the mass moment of inertia is to be determined by evaluating acceleration and deceleration processes or by applying the values from P-0-0510 and P-0-4010.

The mass moment of inertia is determined by evaluating acceleration and deceleration processes:

Cause	Remedy
Drive acceleration too low	Increase "S-0-0260, Positioning acceleration"
Load inertia too high	Increase "S-0-0092, Bipolar torque/force limit value"
Motor speed too low	<p>Up to MPx04VRS: Increase "S-0-0259, Positioning velocity"</p> <p>As of MPx05VRS: Increase "P-0-0171, Drive optimization, velocity"</p>
Not enough measured values for automatic control loop setting	Increase "S-0-0108, Feedrate override"
Load inertia too high	Check design of drive correct, if necessary

10.2.189 C1807 Determining travel range only via travel distance

Allocation	Contained in 02VRS:	«MPB»	«MPH»	«MPD»	
	Contained in 03VRS:	«MPB»	«MPH»	«MPD»	
	Contained in 04VRS:	«MPB»	«MPH»	«MPD»	
	Contained in 05VRS:	«MPB»	«MPH»	«MPD»	
	Contained in 06VRS:	«MPB»	«MPH»	«MPD»	«MPC»
	Contained in 07VRS:	«MPB»	«MPH»	«MPD»	«MPC»
	Contained in 08VRS:	«MPB»	«MPH»	«MPD»	«MPC»
	Supported by supply unit:	«-»			

When the travel range for the automatic control loop setting had been parameterized, the modulo scaling was not taken into account.

Cause	Remedy
There was an attempt to parameterize travel range via "P-0-0166, Drive optimization, end position negative" / "P-0-0167, Drive optimization, end position positive". In this case, travel range can only be parameterized directly	Set travel range by parameterizing "P-0-0169, Drive optimization, travel distance"

C1807 - Attributes Display: C1807
 Ident N°: C1807

10.2.190 C1808 Drive not homed

Allocation	Contained in 02VRS:	«-»	«-»	«-»	
	Contained in 03VRS:	«-»	«-»	«-»	
	Contained in 04VRS:	«-»	«-»	«-»	
	Contained in 05VRS:	«MPB»	«MPH»	«MPD»	
	Contained in 06VRS:	«MPB»	«MPH»	«MPD»	«MPC»
	Contained in 07VRS:	«MPB»	«MPH»	«MPD»	«MPC»
	Contained in 08VRS:	«MPB»	«MPH»	«MPD»	«MPC»
	Supported by supply unit:	«-»			

During the execution of the command "P-0-0162, C1800 Command Drive optimization / command value box", an error occurred. It was impossible to record the tables for cogging torque compensation.

Cause	Remedy
Linear motor hasn't been homed	Establish reference; then record table for cogging torque compensation (see also Functional Description of firmware "Cogging Torque Compensation")

C1808 - Attributes Display: C1808
 Ident N°: C1808

10.2.191 C2001 Command not enabled

Allocation	Contained in 02VRS:	«MPB»	«MPH»	«MPD»	
	Contained in 03VRS:	«MPB»	«MPH»	«MPD»	
	Contained in 04VRS:	«MPB»	«MPH»	«MPD»	
	Contained in 05VRS:	«MPB»	«MPH»	«MPD»	
	Contained in 06VRS:	«MPB»	«MPH»	«MPD»	«MPC»
	Contained in 07VRS:	«MPB»	«MPH»	«MPD»	«MPC»
	Contained in 08VRS:	«MPB»	«MPH»	«MPD»	«MPC»
	Supported by supply unit:	«-»			

The execution of the "Release motor holding brake" command (C2000) was aborted by an error.

Diagnostic Command Messages

Cause	Remedy
Command can only be executed, if it is allowed by bit 5 in parameter "P-0-0525, Holding brake control word"	Set bit 5 in parameter P-0-0525 to "1"

See also Functional Description of firmware "Motor Holding Brake"

C2001 - Attributes Display: C2001
 Ident N°: C2001

10.2.192 C2101 Holding system check only possible with drive enable

Allocation	Contained in 02VRS:	«MPB»	«MPH»	«MPD»	
	Contained in 03VRS:	«MPB»	«MPH»	«MPD»	
	Contained in 04VRS:	«MPB»	«MPH»	«MPD»	
	Contained in 05VRS:	«MPB»	«MPH»	«MPD»	
	Contained in 06VRS:	«MPB»	«MPH»	«MPD»	«MPC»
	Contained in 07VRS:	«MPB»	«MPH»	«MPD»	«MPC»
	Contained in 08VRS:	«MPB»	«MPH»	«MPD»	«MPC»
	Supported by supply unit:	«-»			

It is impossible to execute the "brake check" command (C2100).

Cause	Remedy
Command "P-0-0541, C2100 Brake check command" was activated, but drive enable ("AF") had not been set.	Switch drive to "AF", then start command C2100

See also Functional Description of firmware "Motor Holding Brake"

C2101 - Attributes Display: C2101
 Ident N°: C2101

10.2.193 C2103 Holding brake: Torque too low

Allocation	Contained in 02VRS:	«MPB»	«MPH»	«MPD»	
	Contained in 03VRS:	«MPB»	«MPH»	«MPD»	
	Contained in 04VRS:	«MPB»	«MPH»	«MPD»	
	Contained in 05VRS:	«MPB»	«MPH»	«MPD»	
	Contained in 06VRS:	«MPB»	«MPH»	«MPD»	«MPC»
	Contained in 07VRS:	«MPB»	«MPH»	«MPD»	«MPC»
	Contained in 08VRS:	«MPB»	«MPH»	«MPD»	«MPC»
	Supported by supply unit:	«-»			

When the command "P-0-0541, C2100 Holding system check command" had been executed, the holding torque of the brake was detected to be too low.

Cause	Remedy
Due to storage, brake is covered with an oxide layer. - or - Brake is wetted with oil or grease. - or - Brake is worn.	Start command "P-0-0544, C3900 Command Abrasion of holding brake" for holding system check again to reestablish full brake torque by repeated resurfacing of holding brake. If brake torque is still too low after several attempts to reestablish it, brake or motor must be replaced.

See also Functional Description of firmware "Holding Brake"

C2103 - Attributes Display: C2103
 Ident N°: C2103

10.2.194 C2104 Command execution impossible

Allocation	Contained in 02VRS:	«MPB»	«MPH»	«MPD»	
	Contained in 03VRS:	«MPB»	«MPH»	«MPD»	
	Contained in 04VRS:	«MPB»	«MPH»	«MPD»	
	Contained in 05VRS:	«MPB»	«MPH»	«MPD»	
	Contained in 06VRS:	«MPB»	«MPH»	«MPD»	«MPC»
	Contained in 07VRS:	«MPB»	«MPH»	«MPD»	«MPC»
	Contained in 08VRS:	«MPB»	«MPH»	«MPD»	«MPC»
	Supported by supply unit:	«-»			

The command "P-0-0541, C2100 Holding system check command" could not be started.

Cause	Remedy
Brake control has not been activated in parameter "P-0-0525, Holding brake control word"	Activate brake control in parameter "P-0-0525, Holding brake control word"
Value in "P-0-0540, Torque of holding brake" is "0"	Enter correct value for "P-0-0540, Torque of holding brake"
Drive is in a safety related operating status, cf. "P-0-3213, Safety technology operating status" or "P-0-3213, Safety technology status"	Deselect safety related operating status and execute "C2100 Holding system check command" again

See also Functional Description of firmware "Holding Brake"

See also documentation "Integrated Safety Technology"

C2104 - Attributes	Display:	C2104
	Ident N°:	C2104

10.2.195 C2105 Load of holding system greater than test torque

Allocation	Contained in 02VRS:	«-»	«-»	«-»	
	Contained in 03VRS:	«MPB»	«MPH»	«MPD»	
	Contained in 04VRS:	«MPB»	«MPH»	«MPD»	
	Contained in 05VRS:	«MPB»	«MPH»	«MPD»	
	Contained in 06VRS:	«MPB»	«MPH»	«MPD»	«MPC»
	Contained in 07VRS:	«MPB»	«MPH»	«MPD»	«MPC»
	Contained in 08VRS:	«MPB»	«MPH»	«MPD»	«MPC»
	Supported by supply unit:	«-»			

Execution of the command "P-0-0541, C2100 Holding system check command" was aborted. The current load due to weight of the axis ("holding system") was detected to be greater than the force or the torque with which the blocking of the axis is checked on the drive side.



To reliably block the axis, the holding torque or the holding force must be greater than the load due to weight of the axis. Therefore, the test torque or the test force must be greater than the load due to weight, too.

The test torque depends on the value in P-0-0547:

- If P-0-0547 is unequal to "0", the value of the test torque is 1.3 times the value of "P-0-0547, Nominal load of holding system".
- If P-0-0547 is equal to "0", the test torque is equal to the value entered in "P-0-0540, Torque of holding brake".

Diagnostic Command Messages

Cause	Remedy
Load due to weight is greater than nominal load which was input (if "P-0-0547, Nominal load of holding system" is unequal to "0")	Remedy during initial commissioning: Determine load due to weight of axis and compare it to value entered in "P-0-0547, Nominal load of holding system". If necessary, correct (increase) value.
	Remedy during operation of axis drive: DANGER! Dangerous movements! Danger to life, risk of injury, serious injury or property damage! Load due to weight of axis was increased compared to initial commissioning. Check cause. Reduce load due to weight - or - Determine load due to weight of axis and compare it to value entered in "P-0-0547, Nominal load of holding system". If necessary, increase value in "P-0-0547, Nominal load of holding system". Check drive dimensioning!
Load due to weight is greater than holding torque or holding force of holding brake (if "P-0-0547, Nominal load of holding system" = "0")	Remedy during initial commissioning: Determine load due to weight of axis and compare it to value of "P-0-0540, Torque of holding brake". Mount stronger holding brake, if necessary.
	Remedy during operation of axis drive: DANGER! Dangerous movements! Danger to life, risk of injury, serious injury or property damage! Load due to weight of axis is higher than "P-0-0540, Torque of holding brake". Check cause. Reduce load due to weight - or - Determine load due to weight of axis and compare it to value of "P-0-0540, Torque of holding brake". Mount stronger holding brake, if necessary. Check drive dimensioning!

See also Functional Description of firmware "Holding Brake"

C2105 - Attributes **Display:** C2105
Ident N°: C2105

10.2.196 C2106 Test torque of holding system not reached

Allocation	Contained in 02VRS:	«-»	«-»	«-»	
	Contained in 03VRS:	«MPB»	«MPH»	«MPD»	
	Contained in 04VRS:	«MPB»	«MPH»	«MPD»	
	Contained in 05VRS:	«MPB»	«MPH»	«MPD»	
	Contained in 06VRS:	«MPB»	«MPH»	«MPD»	«MPC»
	Contained in 07VRS:	«MPB»	«MPH»	«MPD»	«MPC»
	Contained in 08VRS:	«MPB»	«MPH»	«MPD»	«MPC»
	Supported by supply unit:	«-»			

The execution of the command "P-0-0541, C2100 Holding system check command" was aborted. The holding system check detected that it is impossible to generate the test torque required on the drive side with which the blocking of the axis is to be tested.

Diagnostic Command Messages

The test lasts for one second with regard to the 1.3-fold value of

- "P-0-0547, Nominal load of holding system" (if P-0-0547 is unequal "0")
or
- "P-0-0540, Torque of holding brake" (if P-0-0547="0").

Cause	Remedy
<p>Static limitation of drive torque or drive force is active</p>	<p>Check or increase static torque or force limit values so that 1.3-fold value of "P-0-0547, Nominal load of holding system" (if P-0-0547 is unequal "0") or "P-0-0540, Torque of holding brake" (if P-0-0547="0") is possible. By way of trial, set maximum values, if necessary:</p> <ul style="list-style-type: none"> • "S-0-0092, Bipolar torque/force limit value" • "S-0-0082, Torque/force limit value positive" • "S-0-0083, Torque/force limit value negative" • "P-0-0109, Torque/force peak limit"
<p>Dynamic limitation of drive torque or drive force is active and "P-0-0547, Nominal load of holding system" is unequal "0"</p>	<p>Check dynamic limitations (static limit values mustn't be effective!).</p> <p>If value displayed in "P-0-0444, Actual value peak torque limit" does not allow 1.3-fold of "P-0-0547, Nominal load of holding system", drive is underdimensioned! Check thermal load of motor and controller. Replace overloaded component(s) by appropriate component(s), if necessary.</p>
<p>Dynamic limitation of drive torque or drive force is active and "P-0-0547, Nominal load of holding system"="0"</p>	<p>Check dynamic limitations (static limit values mustn't be effective!).</p> <p>If value displayed in "P-0-0444, Actual value peak torque limit" does not allow 1.3-fold of "P-0-0540, Torque of holding brake", check whether value depending on axis load can be input in "P-0-0547, Nominal load of holding system". If not, controller is underdimensioned! Replace controller by an appropriate one, if necessary.</p>

Diagnostic Command Messages

Cause	Remedy
<p>If value of "P-0-0547, Nominal load of holding system" is unequal "0":</p> <p>Input of nominal load of axis ("P-0-0547, Nominal load of holding system") is greater than actual load due to weight.</p> <p>This means that load current demanded from controller cannot be made available for test duration. Dynamic limitation of drive torque or drive force is active</p>	<p>Remedy during initial commissioning:</p> <p>Determine force due to weight of axis and compare it to value entered in "P-0-0547, Nominal load of holding system". If "P-0-0547, Nominal load of holding system" is greater and no check for "increased holding torque or holding force" is to be run, set (reduce) "P-0-0547, Nominal load of holding system" according to load due to weight.</p> <p>If check is to be run for entered value, controller is underdimensioned; see remedy for "Dynamic limitation of drive torque or drive force is active"</p> <p>Remedy during operation of axis drive:</p> <p>DANGER! Dangerous movements! Danger to life, risk of injury, serious injury or property damage! Check is run for holding torque or holding force of holding brake. Controller is underdimensioned.</p> <p>If possible, carry out remedy during initial commissioning (see above)</p> <p>- or -</p> <p>Mount controller with sufficiently high continuous current, see remedy for "Dynamic limitation of drive torque or drive force is active"</p>
<p>If "P-0-0547, Nominal load of holding system"="0":</p> <p>Holding torque or holding force of holding brake is greater than actual load due to weight of axis.</p> <p>This means that load current demanded from controller cannot be made available for test duration. Dynamic limitation of drive torque or drive force is active</p>	<p>Remedy during initial commissioning:</p> <p>Determine load due to weight of axis and compare it to value of "P-0-0540, Torque of holding brake". If load due to weight requires less holding torque than "P-0-0540, Torque of holding brake" displays and no check for "increased holding torque or holding force" is to be run, enter actual load due to weight in "P-0-0547, Nominal load of holding system". In this way, actual axis load is checked in the future. Otherwise, controller is underdimensioned, see remedy for "Dynamic limitation of drive torque or drive force is active"</p> <p>Remedy during operation of axis drive:</p> <p>DANGER! Dangerous movements! Danger to life, risk of injury, serious injury or property damage! Check is run for holding torque or holding force of holding brake. Controller is underdimensioned.</p> <p>If possible, carry out remedy during initial commissioning (see above)</p> <p>- or -</p> <p>Mount controller with sufficiently high continuous current, see remedy for "Dynamic limitation of drive torque or drive force is active"</p>

See also Functional Description of firmware "Holding Brake"

C2106 - Attributes

Display: C2106
Ident N°: C2106

10.2.197 C2107 Redundant holding brake: Torque too low

Allocation	Contained in 02VRS:	«-»	«-»	«-»	
	Contained in 03VRS:	«-»	«-»	«-»	
	Contained in 04VRS:	«-»	«MPH»	«MPD»	
	Contained in 05VRS:	«-»	«MPH»	«MPD»	
	Contained in 06VRS:	«-»	«MPH»	«MPD»	«MPC»
	Contained in 07VRS:	«-»	«MPH»	«MPD»	«MPC»
	Contained in 08VRS:	«-»	«MPH»	«MPD»	«MPC»
	Supported by supply unit:	«-»			

The execution of the command "P-0-0541, C2100 Holding system check command" was aborted. Due to the test torque added, the redundant holding brake was inadmissibly distorted.

Cause	Remedy
Due to a too high degree of backlash or torsion, allowed travel distance selected in "P-0-3310, Safe holding system: travel range brake check" is too short	Check parameterization of "P-0-3310, Safe holding system: travel range brake check"
Parameter "P-0-3303, Safe holding system: nominal load" is greater than value entered in "P-0-0547, Nominal load of holding system"	Change parameter setting: Test torque in "P-0-0547, Nominal load of holding system" should correspond to test torque in "P-0-3303, Safe holding system: nominal load"
Redundant holding brake no longer achieves required brake torque	Carry out resurfacing procedure according to manufacturer's specification - or - Replace redundant holding brake

See also Functional Description of firmware "Holding Brake"

C2107 - Attributes	Display:	C2107
	Ident N°:	C2107

10.2.198 C2108 Error when releasing the holding system

Allocation	Contained in 02VRS:	«-»	«-»	«-»	
	Contained in 03VRS:	«-»	«-»	«-»	
	Contained in 04VRS:	«MPB»	«MPH»	«MPD»	
	Contained in 05VRS:	«MPB»	«MPH»	«MPD»	
	Contained in 06VRS:	«MPB»	«MPH»	«MPD»	«MPC»
	Contained in 07VRS:	«MPB»	«MPH»	«MPD»	«MPC»
	Contained in 08VRS:	«MPB»	«MPH»	«MPD»	«MPC»
	Supported by supply unit:	«-»			

The execution of the command "P-0-0541, C2100 Holding system check command" was aborted. An error was detected when the redundant holding brake was released.

Diagnostic Command Messages

Cause	Remedy
Incorrect control of holding system, holding system does not release	Check wiring - or - If third-party brake was connected: Check parameter setting
Test torque for releasing holding system set too low	Increase value in parameter "P-0-0545, Test torque for releasing holding system"
Increased breakaway torque of axis due to increased friction within installation, etc.	Remove malfunction in installation

See also Functional Description of firmware "Holding Brake"

C2108 - Attributes Display: C2108
 Ident N°: C2108

10.2.199 C2109 SBS: Test torque invalid

Allocation	Contained in 02VRS:	«-»	«-»	«-»	
	Contained in 03VRS:	«-»	«-»	«-»	
	Contained in 04VRS:	«-»	«-»	«-»	
	Contained in 05VRS:	«MPB»	«MPH»	«MPD»	
	Contained in 06VRS:	«MPB»	«MPH»	«MPD»	«MPC»
	Contained in 07VRS:	«MPB»	«MPH»	«MPD»	«MPC»
	Contained in 08VRS:	«MPB»	«MPH»	«MPD»	«MPC»
	Supported by supply unit:	«-»			



Up to MPx06, the name of this diagnostic message was "C2109 Safety related holding system: Test torque invalid".

The execution of the command "P-0-0541, C2100 Holding system check command" was aborted. The value of the applied test torque is not verisimilar, i.e. the measured torque does not comply with the calculated torque of the safety technology channels.

Cause	Remedy
Incorrect parameterization P-0-3304 ≠ P-0-0051	Check parameterization
"P-0-0051, Torque/force constant" was changed due to replacement of motor by motor which is not of the same type of construction	Mount appropriate motor according to safety technology acceptance test protocol - or - Carry out safety technology acceptance test again

See also Functional Description of firmware "Holding Brake"

C2109 - Attributes Display: C2109
 Ident N°: C2109

10.2.200 C2202 Error when writing data to non-volatile memory

Allocation	Contained in 02VRS:	«MPB»	«MPH»	«MPD»	
	Contained in 03VRS:	«MPB»	«MPH»	«MPD»	
	Contained in 04VRS:	«MPB»	«MPH»	«MPD»	
	Contained in 05VRS:	«MPB»	«MPH»	«MPD»	
	Contained in 06VRS:	«MPB»	«MPH»	«MPD»	«MPC»
	Contained in 07VRS:	«MPB»	«MPH»	«MPD»	«MPC»
	Contained in 08VRS:	«MPB»	«MPH»	«MPD»	«MPC»
Supported by supply unit:	«-»				

During the execution of the "S-0-0264, C2200 Backup working memory procedure command" an error occurred.

Cause	Remedy
It was impossible to address active, non-volatile memory (internal flash memory or MMC, if plugged in) without error.	First start command "S-0-0264, C2200 Backup working memory procedure command" again. If error occurs again, then replace MMC (if plugged in) if necessary, then start command again. If error occurs again, contact our service department.

C2202 - Attributes Display: C2202
 Ident N°: C2202

10.2.201 C2301 Error when reading non-volatile memory

Allocation	Contained in 02VRS:	«MPB»	«MPH»	«MPD»	
	Contained in 03VRS:	«MPB»	«MPH»	«MPD»	
	Contained in 04VRS:	«MPB»	«MPH»	«MPD»	
	Contained in 05VRS:	«MPB»	«MPH»	«MPD»	
	Contained in 06VRS:	«MPB»	«MPH»	«MPD»	«MPC»
	Contained in 07VRS:	«MPB»	«MPH»	«MPD»	«MPC»
	Contained in 08VRS:	«MPB»	«MPH»	«MPD»	«MPC»
Supported by supply unit:	«-»				

During the execution of the "S-0-0263, C2300 Load working memory procedure command" an error occurred.

Cause	Remedy
It was impossible to read active, non-volatile memory [internal flash memory or MMC (if plugged in)] without error.	Restart command. If error occurs again, contact our service department. Have control section checked for functional safety.

C2301 - Attributes Display: C2301
 Ident N°: C2301

10.2.202 C2302 Error when converting parameters

Allocation	Contained in 02VRS:	«MPB»	«MPH»	«MPD»	
	Contained in 03VRS:	«MPB»	«MPH»	«MPD»	
	Contained in 04VRS:	«MPB»	«MPH»	«MPD»	
	Contained in 05VRS:	«MPB»	«MPH»	«MPD»	
	Contained in 06VRS:	«MPB»	«MPH»	«MPD»	«MPC»
	Contained in 07VRS:	«MPB»	«MPH»	«MPD»	«MPC»
	Contained in 08VRS:	«MPB»	«MPH»	«MPD»	«MPC»
Supported by supply unit:	«-»				

During the execution of the "S-0-0263, C2300 Load working memory procedure command" an error occurred.

Diagnostic Command Messages

Cause	Remedy
When reading parameters from active, non-volatile memory, an error occurred.	Enter faulty parameter values correctly by hand and save them again in non-volatile memory.

C2302 - Attributes **Display:** C2302
Ident N°: C2302

10.2.203 C2402 Error when saving parameters

Allocation	Contained in 02VRS:	«MPB»	«MPH»	«MPD»	
	Contained in 03VRS:	«MPB»	«MPH»	«MPD»	
	Contained in 04VRS:	«MPB»	«MPH»	«MPD»	
	Contained in 05VRS:	«MPB»	«MPH»	«MPD»	
	Contained in 06VRS:	«MPB»	«MPH»	«MPD»	«MPC»
	Contained in 07VRS:	«MPB»	«MPH»	«MPD»	«MPC»
	Contained in 08VRS:	«MPB»	«MPH»	«MPD»	«MPC»
	Supported by supply unit:	«-»			

During the execution of the "S-0-0293, C2400 Selectively backup working memory procedure command" an error occurred.

Cause	Remedy
It was impossible to address active, non-volatile memory (internal flash memory or MMC, if plugged in) without error.	Start "S-0-0293, C2400 Selectively backup working memory procedure command" again. If error occurs again, then replace MMC (if plugged in) if necessary, then start command again. If error occurs again, contact our service department.

C2402 - Attributes **Display:** C2402
Ident N°: C2402

10.2.204 C2502 Error when accessing the MMC

Allocation	Contained in 02VRS:	«MPB»	«MPH»	«MPD»	
	Contained in 03VRS:	«MPB»	«MPH»	«MPD»	
	Contained in 04VRS:	«MPB»	«MPH»	«MPD»	
	Contained in 05VRS:	«MPB»	«MPH»	«MPD»	
	Contained in 06VRS:	«MPB»	«MPH»	«MPD»	«MPC»
	Contained in 07VRS:	«MPB»	«MPH»	«MPD»	«MPC»
	Contained in 08VRS:	«MPB»	«MPH»	«MPD»	«MPC»
	Supported by supply unit:	«-»			

During the execution of "P-0-4091, C2500 Copy IDN from optional memory to internal memory" an error occurred.



The MMC can only be used as an optional memory for control sections with MMC slot.

Cause	Remedy
MMC had not been active before, there haven't been any valid parameter contents stored on it	Write parameter contents of internal memory to MMC by executing command "P-0-4092, C2600 Copy IDN from internal memory to optional memory"
MMC has not (or not completely) been plugged in the MMC slot provided for this purpose	Put MMC into controller. Then restart command "P-0-4091, C2500 Copy IDN from optional memory to internal memory"

Diagnostic Command Messages

Cause	Remedy
Error occurs sporadically due to voltage fluctuations in device	Check power supply and then restart command "P-0-4091, C2500 Copy IDN from optional memory to internal memory". If error occurs repeatedly, you should contact our service department
MMC was not or not correctly formatted	Format MMC or contact our service department. Then restart command "P-0-4091, C2500 Copy IDN from optional memory to internal memory"
MMC is defective	Check MMC and restart command "P-0-4091, C2500 Copy IDN from optional memory to internal memory". If diagnostic message appears repeatedly: replace MMC
MMC slot in control section is defective	Check MMC slot and, if necessary, replace control section or complete drive controller



If the MMC must be replaced, the values stored on it are lost.



Only Rexroth service engineers or especially trained users are allowed to replace the control section. The replacement of the entire drive controller is described in the Project Planning Manual for the power section.

For removing command errors see "Command Errors"

See also Functional Description of firmware "MultiMediaCard (MMC)"

C2502 - Attributes Display: C2502
 Ident N°: C2502

10.2.205 C2504 Error when writing data to internal memory

Allocation	Contained in 02VRS:	«MPB»	«MPH»	«MPD»	
	Contained in 03VRS:	«MPB»	«MPH»	«MPD»	
	Contained in 04VRS:	«MPB»	«MPH»	«MPD»	
	Contained in 05VRS:	«MPB»	«MPH»	«MPD»	
	Contained in 06VRS:	«MPB»	«MPH»	«MPD»	«MPC»
	Contained in 07VRS:	«MPB»	«MPH»	«MPD»	«MPC»
	Contained in 08VRS:	«MPB»	«MPH»	«MPD»	«MPC»
	Supported by supply unit:	«-»			

During the execution of the "P-0-4091, C2500 Copy IDN from optional memory to internal memory" an error occurred.

Cause	Remedy
Error when writing to internal, non-volatile flash memory	Restart "P-0-4091, C2500 Copy IDN from optional memory to internal memory". If diagnostic message is displayed repeatedly: contact our service department

C2504 - Attributes Display: C2504
 Ident N°: C2504

Diagnostic Command Messages

10.2.206 C2602 Error when accessing the MMC

Allocation	Contained in 02VRS:	«MPB»	«MPH»	«MPD»	
	Contained in 03VRS:	«MPB»	«MPH»	«MPD»	
	Contained in 04VRS:	«MPB»	«MPH»	«MPD»	
	Contained in 05VRS:	«MPB»	«MPH»	«MPD»	
	Contained in 06VRS:	«MPB»	«MPH»	«MPD»	«MPC»
	Contained in 07VRS:	«MPB»	«MPH»	«MPD»	«MPC»
	Contained in 08VRS:	«MPB»	«MPH»	«MPD»	«MPC»
	Supported by supply unit:	«-»			

During the execution of the command "P-0-4092, C2600 Copy IDN from internal memory to optional memory" a check is run in order to find out whether a functioning MMC (MultiMediaCard) is available.



The MMC can only be used as an optional memory for control sections with MMC slot.

Cause	Remedy
MMC has not (or not completely) been plugged in MMC slot provided for this purpose	Put MMC into controller. Then restart command "P-0-4092, C2600 Copy IDN from internal memory to optional memory"
MMC was not or not correctly formatted	Format MMC or contact our service department. Then restart command "P-0-4092, C2600 Copy IDN from internal memory to optional memory"
At least one of required files is missing in "Parameters" folder on MMC	Check whether files with extension "...#1.pbf" or "...#1.rbf" are contained in "Parameters" folder on MMC. For double-axis devices, files with extension "...#2.pbf" or "...#2.rbf" have to be available! If diagnostic message appears repeatedly: replace MMC
MMC is defective	Check MMC and restart command "P-0-4092, C2600 Copy IDN from internal memory to optional memory". If diagnostic message appears repeatedly: replace MMC
MMC slot in control section is defective	Check MMC slot and, if necessary, replace control section or entire drive controller



Only Rexroth service engineers or especially trained users are allowed to replace the control section. The replacement of the entire drive controller is described in the Project Planning Manual for the power section.



If the MMC must be replaced, the values stored on it are lost.

See also Functional Description of firmware "MultiMediaCard (MMC)"

C2602 - Attributes

Display: C2602
Ident N°: C2602

10.2.207 C2604 Error when reading the internal memory

Allocation	Contained in 02VRS:	«MPB»	«MPH»	«MPD»	
	Contained in 03VRS:	«MPB»	«MPH»	«MPD»	
	Contained in 04VRS:	«MPB»	«MPH»	«MPD»	
	Contained in 05VRS:	«MPB»	«MPH»	«MPD»	
	Contained in 06VRS:	«MPB»	«MPH»	«MPD»	«MPC»
	Contained in 07VRS:	«MPB»	«MPH»	«MPD»	«MPC»
	Contained in 08VRS:	«MPB»	«MPH»	«MPD»	«MPC»
	Supported by supply unit:	«-»			

During the execution of the "P-0-4092, C2600 Copy IDN from internal memory to optional memory" an error occurred.

Cause	Remedy
Error when reading internal flash memory	Restart "P-0-4092, C2600 Copy IDN from internal memory to optional memory". If diagnostic message is displayed repeatedly: save parameter values via serial interface or SERCOS interface, if required. In the medium term, have control section checked for functional safety

C2604 - Attributes Display: C2604
 Ident N°: C2604

10.2.208 C2801 Analog input not configured

Allocation	Contained in 02VRS:	«MPB»	«MPH»	«MPD»	
	Contained in 03VRS:	«MPB»	«MPH»	«MPD»	
	Contained in 04VRS:	«MPB»	«MPH»	«MPD»	
	Contained in 05VRS:	«MPB»	«MPH»	«MPD»	
	Contained in 06VRS:	«MPB»	«MPH»	«MPD»	«MPC»
	Contained in 07VRS:	«MPB»	«MPH»	«MPD»	«MPC»
	Contained in 08VRS:	«MPB»	«MPH»	«MPD»	«MPC»
	Supported by supply unit:	«-»			

During the execution of the command for adjusting the analog input ("P-0-0220, C2800 Analog input adjust command") an error was detected. The execution of the command was aborted.

Cause	Remedy
Command for automatic adjust of analog input was started although there hadn't any analog input been configured on drive controller	Check parameter "P-0-0218, Analog input, control parameter". In this parameter an analog input has to be assigned for selected analog input assignment

See also Functional Description of firmware "Analog Input"

C2801 - Attributes Display: C2801
 Ident N°: C2801

Diagnostic Command Messages

10.2.209 C2802 Oscillations of input signal outside tolerance range

Allocation	Contained in 02VRS:	«MPB»	«MPH»	«MPD»	
	Contained in 03VRS:	«MPB»	«MPH»	«MPD»	
	Contained in 04VRS:	«MPB»	«MPH»	«MPD»	
	Contained in 05VRS:	«MPB»	«MPH»	«MPD»	
	Contained in 06VRS:	«MPB»	«MPH»	«MPD»	«MPC»
	Contained in 07VRS:	«MPB»	«MPH»	«MPD»	«MPC»
	Contained in 08VRS:	«MPB»	«MPH»	«MPD»	«MPC»
Supported by supply unit:	«-»				

When the command "P-0-0220, C2800 Analog input adjust command" is executed, the quality of the reference signal used is checked.

Cause	Remedy
During gain adjust , reference voltage was used that fluctuates by more than 1% of input voltage range	Check input signal used for precision; if necessary, use different calibration signal
During zero point adjust , input voltage is not exactly "0" and fluctuates by more than 1% of input voltage range	Short circuit analog inputs by means of wire bridge

See also Functional Description of firmware "Analog Inputs"

C2802 - Attributes	Display:	C2802
	Ident N°:	C2802

10.2.210 C2803 Measured values at zero point and max. value identical

Allocation	Contained in 02VRS:	«MPB»	«MPH»	«MPD»	
	Contained in 03VRS:	«MPB»	«MPH»	«MPD»	
	Contained in 04VRS:	«MPB»	«MPH»	«MPD»	
	Contained in 05VRS:	«MPB»	«MPH»	«MPD»	
	Contained in 06VRS:	«MPB»	«MPH»	«MPD»	«MPC»
	Contained in 07VRS:	«MPB»	«MPH»	«MPD»	«MPC»
	Contained in 08VRS:	«MPB»	«MPH»	«MPD»	«MPC»
Supported by supply unit:	«-»				

During the execution of the command "P-0-0220, C2800 Analog input adjust command" an error was detected. The execution of the command was aborted.

Cause	Remedy
During zero point and gain adjust, the same voltage value was provided at analog input	Voltage provided at input has to be modified between two steps of adjust (voltage value for zero adjust: 0 V, voltage value for gain adjust: maximum input voltage)

See also Functional Description of firmware "Analog Inputs"

C2803 - Attributes	Display:	C2803
	Ident N°:	C2803

10.2.211 C2804 Automatic adjustment failed

Allocation	Contained in 02VRS:	«MPB»	«MPH»	«MPD»	
	Contained in 03VRS:	«MPB»	«MPH»	«MPD»	
	Contained in 04VRS:	«MPB»	«MPH»	«MPD»	
	Contained in 05VRS:	«MPB»	«MPH»	«MPD»	
	Contained in 06VRS:	«MPB»	«MPH»	«MPD»	«MPC»
	Contained in 07VRS:	«MPB»	«MPH»	«MPD»	«MPC»
	Contained in 08VRS:	«MPB»	«MPH»	«MPD»	«MPC»
	Supported by supply unit:	«-»			

The command "P-0-0220, C2800 Analog input adjust command" was aborted due to an unspecified error. Please contact our service department.

C2804 - Attributes	Display:	C2804
	Ident N°:	C2804

10.2.212 C2903 Error when accessing the MMC

Allocation	Contained in 02VRS:	«MPB»	«MPH»	«MPD»	
	Contained in 03VRS:	«MPB»	«MPH»	«MPD»	
	Contained in 04VRS:	«MPB»	«MPH»	«MPD»	
	Contained in 05VRS:	«MPB»	«MPH»	«MPD»	
	Contained in 06VRS:	«MPB»	«MPH»	«MPD»	«MPC»
	Contained in 07VRS:	«MPB»	«MPH»	«MPD»	«MPC»
	Contained in 08VRS:	«MPB»	«MPH»	«MPD»	«MPC»
	Supported by supply unit:	«-»			

During the execution of the command "P-0-4072, C2900 Command Firmware update from MMC" a check is run to find out whether the firmware was correctly loaded.

Cause	Remedy
A transmission error occurred during transmission of firmware from MMC	Execute command "P-0-4072, C2900 Command Firmware update from MMC" again If error occurs again, contact a Rexroth service engineer
Firmware file (ibf file) available on MMC is not correct (does not match control section)	Use different MMC with firmware file appropriate for control section <ul style="list-style-type: none"> Control section CSH01.1C: Firmware MPH Control section CSB01.1x: Firmware MPB Control section CDB01.1x: Firmware MPD
Command C6600 was started. During subsequent automatic execution of command C2900, command error C2903 was generated: There is not enough memory space available on MMC to copy new firmware	Via file system of a PC, copy content of MMC, with which error occurred, to MMC with more memory space
Command C6600 was started. During subsequent automatic execution of command C2900, command error C2903 was generated: An error occurred when new firmware had been read or copied. MMC was removed or is defective	Make sure that MMC has been correctly plugged in slot of control section. Execute command "P-0-0666, C6600 Command Restore parameters from MMC" again If error occurs again, replace MMC and check slot on control section; if necessary, replace control section.

Diagnostic Command Messages



Only Rexroth service engineers or especially trained users are allowed to replace the control section. The replacement of the entire drive controller is described in the Project Planning Manual for the power section.



If the command error occurs during the transmission of the firmware to an optional module, the respective system error (F8xxx) is displayed in addition to the command error C2903.

C2903 - Attributes Display: C2903
 Ident N°: C2903

10.2.213 C2904 Error when accessing the flash

Allocation	Contained in 02VRS:	«MPB»	«MPH»	«MPD»	
	Contained in 03VRS:	«MPB»	«MPH»	«MPD»	
	Contained in 04VRS:	«MPB»	«MPH»	«MPD»	
	Contained in 05VRS:	«MPB»	«MPH»	«MPD»	
	Contained in 06VRS:	«MPB»	«MPH»	«MPD»	«MPC»
	Contained in 07VRS:	«MPB»	«MPH»	«MPD»	«MPC»
	Contained in 08VRS:	«MPB»	«MPH»	«MPD»	«MPC»
	Supported by supply unit:	«-»			

During the execution of the "P-0-4072, C2900 Command Firmware update from MMC" an error occurred.

Cause	Remedy
Due to voltage fluctuations in device an active request was aborted	Execute "P-0-4072, C2900 Command Firmware update from MMC" again
Control section is defective	Replace control section or entire drive controller



Only Rexroth service engineers or especially trained users are allowed to replace the control section. The replacement of the entire drive controller is described in the Project Planning Manual for the power section.



If the command error occurs during the transmission of the firmware to an optional module, the respective system error (F8xxx) is displayed in addition to the command error C2904.

C2904 - Attributes Display: C2904
 Ident N°: C2904

10.2.214 C2905 Programmed firmware defective

Allocation	Contained in 02VRS:	«MPB»	«MPH»	«MPD»	
	Contained in 03VRS:	«MPB»	«MPH»	«MPD»	
	Contained in 04VRS:	«MPB»	«MPH»	«MPD»	
	Contained in 05VRS:	«MPB»	«MPH»	«MPD»	
	Contained in 06VRS:	«MPB»	«MPH»	«MPD»	«MPC»
	Contained in 07VRS:	«MPB»	«MPH»	«MPD»	«MPC»
	Contained in 08VRS:	«MPB»	«MPH»	«MPD»	«MPC»
	Supported by supply unit:	«-»			

During the execution of the "P-0-4072, C2900 Command Firmware update from MMC" an error occurred.

Diagnostic Command Messages

10.2.216 C3101 Act. modulo value cycle greater than max. travel range

Allocation	Contained in 02VRS:	«MPB»	«MPH»	«MPD»	
	Contained in 03VRS:	«MPB»	«MPH»	«MPD»	
	Contained in 04VRS:	«MPB»	«MPH»	«MPD»	
	Contained in 05VRS:	«MPB»	«MPH»	«MPD»	
	Contained in 06VRS:	«MPB»	«MPH»	«MPD»	«MPC»
	Contained in 07VRS:	«MPB»	«MPH»	«MPD»	«MPC»
	Contained in 08VRS:	«MPB»	«MPH»	«MPD»	«MPC»
	Supported by supply unit:	«-»			

The command error C3101 is generated when the calculated modulo value for the actual value cycle is greater than the maximum travel range ("S-0-0278, Maximum travel range").

C3101 - Attributes

Display:	C3101
Ident N°:	C3101

10.2.217 C3102 Drive is still in drive enable

Allocation	Contained in 02VRS:	«MPB»	«MPH»	«MPD»	
	Contained in 03VRS:	«MPB»	«MPH»	«MPD»	
	Contained in 04VRS:	«MPB»	«MPH»	«MPD»	
	Contained in 05VRS:	«MPB»	«MPH»	«MPD»	
	Contained in 06VRS:	«MPB»	«MPH»	«MPD»	«MPC»
	Contained in 07VRS:	«MPB»	«MPH»	«MPD»	«MPC»
	Contained in 08VRS:	«MPB»	«MPH»	«MPD»	«MPC»
	Supported by supply unit:	«-»			

Cause	Remedy
Drive enable has been set and command "P-0-0071, C3100 Recalculate actual value cycle" was started	To be able to carry out the command, drive enable has to be removed

C3102 - Attributes

Display:	C3102
Ident N°:	C3102

10.2.218 C3201 Incorrect input for current

Allocation	Contained in 02VRS:	«MPB»	«MPH»	«MPD»	
	Contained in 03VRS:	«MPB»	«MPH»	«MPD»	
	Contained in 04VRS:	«MPB»	«MPH»	«MPD»	
	Contained in 05VRS:	«MPB»	«MPH»	«MPD»	
	Contained in 06VRS:	«MPB»	«MPH»	«MPD»	«MPC»
	Contained in 07VRS:	«MPB»	«MPH»	«MPD»	«MPC»
	Contained in 08VRS:	«MPB»	«MPH»	«MPD»	«MPC»
	Supported by supply unit:	«-»			

During the execution of the command "P-0-4033, C3200 Command Calculate data for asynchronous motor" an error was detected.

Cause	Remedy
List element 1 (rated current) in "P-0-4032, Type plate list asynchronous motor" is outside of useful limits	Value for rated current has to be inside of following limits: rated current > 0.01 * amplifier peak current and rated current < 10 * amplifier peak current

Diagnostic Command Messages

Cause	Remedy
There is no useful relation between list element 4 (rated speed) in "P-0-4032, Type plate list asynchronous motor" and rated frequency, i.e. number of pole pairs cannot be calculated	Correct list element 4 (rated speed) in "P-0-4032, Type plate list asynchronous motor"

C3204 - Attributes Display: C3204
 Ident N°: C3204

10.2.222 C3205 Incorrect input for power factor

Allocation	Contained in 02VRS:	«MPB»	«MPH»	«MPD»	
	Contained in 03VRS:	«MPB»	«MPH»	«MPD»	
	Contained in 04VRS:	«MPB»	«MPH»	«MPD»	
	Contained in 05VRS:	«MPB»	«MPH»	«MPD»	
	Contained in 06VRS:	«MPB»	«MPH»	«MPD»	«MPC»
	Contained in 07VRS:	«MPB»	«MPH»	«MPD»	«MPC»
	Contained in 08VRS:	«MPB»	«MPH»	«MPD»	«MPC»
	Supported by supply unit:	«-»			

During the execution of the command "P-0-4033, C3200 Command Calculate data for asynchronous motor" an error was detected.

Cause	Remedy
Power factor of motor is outside of useful limits	List element 5 (power factor cos phi) in "P-0-4032, Type plate list asynchronous motor" has to be between 0.5 and 0.999

C3205 - Attributes Display: C3205
 Ident N°: C3205

10.2.223 C3206 Incorrect input for power

Allocation	Contained in 02VRS:	«MPB»	«MPH»	«MPD»	
	Contained in 03VRS:	«MPB»	«MPH»	«MPD»	
	Contained in 04VRS:	«MPB»	«MPH»	«MPD»	
	Contained in 05VRS:	«MPB»	«MPH»	«MPD»	
	Contained in 06VRS:	«MPB»	«MPH»	«MPD»	«MPC»
	Contained in 07VRS:	«MPB»	«MPH»	«MPD»	«MPC»
	Contained in 08VRS:	«MPB»	«MPH»	«MPD»	«MPC»
	Supported by supply unit:	«-»			

During the execution of the command "P-0-4033, C3200 Command Calculate data for asynchronous motor" an error was detected.

Cause	Remedy
There is no useful relation between list element 6 (rated power) in "P-0-4032, Type plate list asynchronous motor" and electric power that results from the other rated data. Mechanical power output has to be smaller than effective electric power of motor at rated point because an efficiency of less than 1 is assumed. Furthermore a mechanical power output smaller than 40% of effective electric power is not valid	Correct values in "P-0-4032, Type plate list asynchronous motor" and restart command "P-0-4033, C3200 Command Calculate data for asynchronous motor"

C3206 - Attributes Display: C3206
 Ident N°: C3206

10.2.224 C3207 Type plate list incomplete

Allocation	Contained in 02VRS:	«MPB»	«MPH»	«MPD»	
	Contained in 03VRS:	«MPB»	«MPH»	«MPD»	
	Contained in 04VRS:	«MPB»	«MPH»	«MPD»	
	Contained in 05VRS:	«MPB»	«MPH»	«MPD»	
	Contained in 06VRS:	«MPB»	«MPH»	«MPD»	«MPC»
	Contained in 07VRS:	«MPB»	«MPH»	«MPD»	«MPC»
	Contained in 08VRS:	«MPB»	«MPH»	«MPD»	«MPC»
	Supported by supply unit:	«-»			

During the execution of the command "P-0-4033, C3200 Command Calculate data for asynchronous motor" an error was detected.

Cause	Remedy
List length of parameter "P-0-4032, Type plate list asynchronous motor" is shorter than 6 elements or at least one element has value "0"	Please check: To calculate motor and controller parameters from type plate of an asynchronous motor, value higher than "0" has to be entered in all 6 list elements of "P-0-4032, Type plate list asynchronous motor"

C3207 - Attributes Display: C3207
 Ident N°: C3207

10.2.225 C3208 Error when writing parameters (->S-0-0423)

Allocation	Contained in 02VRS:	«MPB»	«MPH»	«MPD»	
	Contained in 03VRS:	«MPB»	«MPH»	«MPD»	
	Contained in 04VRS:	«MPB»	«MPH»	«MPD»	
	Contained in 05VRS:	«MPB»	«MPH»	«MPD»	
	Contained in 06VRS:	«MPB»	«MPH»	«MPD»	«MPC»
	Contained in 07VRS:	«MPB»	«MPH»	«MPD»	«MPC»
	Contained in 08VRS:	«MPB»	«MPH»	«MPD»	«MPC»
	Supported by supply unit:	«-»			

During the execution of the command "P-0-4033, C3200 Command Calculate data for asynchronous motor" an error occurred (e.g. violation of limit values) when a parameter for motor control was written.

Cause	Remedy
At least one list element in "P-0-4032, Type plate list asynchronous motor" has no useful value so that at least one parameter is outside of allowed limits when motor data are calculated	Correct values in "P-0-4032, Type plate list asynchronous motor" and restart command "P-0-4033, C3200 Command Calculate data for asynchronous motor"

C3208 - Attributes Display: C3208
 Ident N°: C3208

10.2.226 C3209 Command execution impossible

Allocation	Contained in 02VRS:	«-»	«-»	«-»	
	Contained in 03VRS:	«-»	«-»	«-»	
	Contained in 04VRS:	«MPB»	«MPH»	«MPD»	
	Contained in 05VRS:	«MPB»	«MPH»	«MPD»	
	Contained in 06VRS:	«MPB»	«MPH»	«MPD»	«MPC»
	Contained in 07VRS:	«MPB»	«MPH»	«MPD»	«MPC»
	Contained in 08VRS:	«MPB»	«MPH»	«MPD»	«MPC»
	Supported by supply unit:	«-»			

Diagnostic Command Messages

During the execution of the command "P-0-4033, C3200 Command Calculate motor data" an error occurred.

Cause	Remedy
Command cannot be executed with connected motor	Connect asynchronous motor and parameterize "P-4014, Type of construction of motor" accordingly

C3209 - Attributes Display: C3209
 Ident N°: C3209

10.2.227 C3501 Acquisition velocity not allowed

Allocation	Contained in 02VRS:	«MPB»	«MPH»	«MPD»
	Contained in 03VRS:	«MPB»	«MPH»	«MPD»
	Contained in 04VRS:	«MPB»	«MPH»	«MPD»
	Contained in 05VRS:	«MPB»	«MPH»	«MPD»
	Contained in 06VRS:	«-»	«-»	«-» «-»
	Contained in 07VRS:	«-»	«-»	«-» «-»
	Contained in 08VRS:	«-»	«-»	«-» «-»
	Supported by supply unit:	«-»		

During the execution of the command "P-0-0340, C3500 Command Determine encoder correction values" an error was detected.

To acquire the signal shape the axis has to be moved at constant velocity; the velocity command value has to be within an allowed range of values. The controller monitors the velocity command value and, if necessary, signals inadmissible acquisition velocity.

Cause	Remedy
Acquisition velocity outside of allowed range of values	Check range of values for acquisition velocity (range of values relates to encoder shaft or sensor head)

"Acquisition velocity" see Functional Description of firmware "Encoder Correction"

C3501 - Attributes Display: C3501
 Ident N°: C3501

10.2.228 C3502 Motor encoder not available

Allocation	Contained in 02VRS:	«MPB»	«MPH»	«MPD»
	Contained in 03VRS:	«MPB»	«MPH»	«MPD»
	Contained in 04VRS:	«MPB»	«MPH»	«MPD»
	Contained in 05VRS:	«MPB»	«MPH»	«MPD»
	Contained in 06VRS:	«-»	«-»	«-» «-»
	Contained in 07VRS:	«-»	«-»	«-» «-»
	Contained in 08VRS:	«-»	«-»	«-» «-»
	Supported by supply unit:	«-»		

During the execution of the command "P-0-0340, C3500 Command Determine encoder correction values" an error was detected.

Diagnostic Command Messages

Cause	Remedy
Motor encoder does not supply any signal or is not recognized by controller	Check whether signals of motor encoder are reaching controller. If necessary, replace motor encoder or motor encoder cable
Motor encoder not available, not connected or not registered ("open-loop" operation)	Connect motor encoder and register it in "P-0-0074, Encoder type 1 (motor encoder)"

C3502 - Attributes Display: C3502
 Ident N°: C3502

10.2.229 C3503 Optional encoder not available

Allocation	Contained in 02VRS:	«MPB»	«MPH»	«MPD»
	Contained in 03VRS:	«MPB»	«MPH»	«MPD»
	Contained in 04VRS:	«MPB»	«MPH»	«MPD»
	Contained in 05VRS:	«MPB»	«MPH»	«MPD»
	Contained in 06VRS:	«-»	«-»	«-»
	Contained in 07VRS:	«-»	«-»	«-»
	Contained in 08VRS:	«-»	«-»	«-»
	Supported by supply unit:	«-»		

During the execution of the command "P-0-0340, C3500 Command Determine encoder correction values" an error was detected.

Cause	Remedy
Optional encoder does not supply any signal or is not recognized by controller	Check whether signals of optional encoder are reaching controller. If necessary, replace encoder or encoder cable
Optional encoder not available, not connected or not registered	Connect optional encoder and register it in "P-0-0075, Encoder type 2 (optional encoder)"

C3503 - Attributes Display: C3503
 Ident N°: C3503

10.2.230 C3504 Measuring encoder not available

Allocation	Contained in 02VRS:	«MPB»	«MPH»	«MPD»
	Contained in 03VRS:	«MPB»	«MPH»	«MPD»
	Contained in 04VRS:	«MPB»	«MPH»	«MPD»
	Contained in 05VRS:	«MPB»	«MPH»	«MPD»
	Contained in 06VRS:	«-»	«-»	«-»
	Contained in 07VRS:	«-»	«-»	«-»
	Contained in 08VRS:	«-»	«-»	«-»
	Supported by supply unit:	«-»		

During the execution of the command "P-0-0340, C3500 Command Determine encoder correction values" an error was detected.

Cause	Remedy
Measuring encoder does not supply any signal or is not recognized by controller	Check whether signals of measuring encoder are reaching controller. If necessary, replace encoder or encoder cable
Measuring encoder not available, not connected or not registered	Connect measuring encoder and register it in "P-0-0076, Encoder type 3 (measuring encoder)"

C3504 - Attributes Display: C3504
 Ident N°: C3504

Diagnostic Command Messages

10.2.231 C3505 No encoder selected

Allocation	Contained in 02VRS:	«MPB»	«MPH»	«MPD»
	Contained in 03VRS:	«MPB»	«MPH»	«MPD»
	Contained in 04VRS:	«MPB»	«MPH»	«MPD»
	Contained in 05VRS:	«MPB»	«MPH»	«MPD»
	Contained in 06VRS:	«-»	«-»	«-»
	Contained in 07VRS:	«-»	«-»	«-»
	Contained in 08VRS:	«-»	«-»	«-»
	Supported by supply unit:	«-»		

During the execution of the command "P-0-0340, C3500 Command Determine encoder correction values" an error was detected.

Cause	Remedy
At start of command "P-0-0340, C3500 Command Determine encoder correction values" there hadn't any encoder been selected in "P-0-0341, Control word for encoder correction"	Select encoder in "P-0-0341, Control word for encoder correction"

C3505 - Attributes Display: C3505
 Ident N°: C3505

10.2.232 C3506 Correction value table cannot be stored

Allocation	Contained in 02VRS:	«MPB»	«MPH»	«MPD»
	Contained in 03VRS:	«MPB»	«MPH»	«MPD»
	Contained in 04VRS:	«MPB»	«MPH»	«MPD»
	Contained in 05VRS:	«MPB»	«MPH»	«MPD»
	Contained in 06VRS:	«-»	«-»	«-»
	Contained in 07VRS:	«-»	«-»	«-»
	Contained in 08VRS:	«-»	«-»	«-»
	Supported by supply unit:	«-»		

During the execution of the command "P-0-0340, C3500 Command Determine encoder correction values" an error was detected.

Cause	Remedy
Determined correction value table ("P-0-0342, Correction value table for encoder correction") is incomplete	Execute command "P-0-0340, C3500 Command Determine encoder correction values" again, select different acquisition velocity
Due to hardware problem, determined correction value table ("P-0-0342, Correction value table for encoder correction") cannot be stored in drive	Replace device

C3506 - Attributes Display: C3506
 Ident N°: C3506

Diagnostic Command Messages

10.2.235 C3603 Device current limit too low

Allocation	Contained in 02VRS:	«-»	«-»	«-»	
	Contained in 03VRS:	«MPB»	«MPH»	«MPD»	
	Contained in 04VRS:	«MPB»	«MPH»	«MPD»	
	Contained in 05VRS:	«MPB»	«MPH»	«MPD»	
	Contained in 06VRS:	«MPB»	«MPH»	«MPD»	«MPC»
	Contained in 07VRS:	«MPB»	«MPH»	«MPD»	«MPC»
	Contained in 08VRS:	«MPB»	«MPH»	«MPD»	«MPC»
	Supported by supply unit:	«-»			

When executing the command "P-0-0565, C3600 Command Motor data identification" the drive detected that the required measuring current couldn't be generated.

Cause	Remedy
Controller cannot make sufficient measuring current available	If possible, reduce value in "P-0-0001, Switching frequency of the power output stage" - or - use controller with higher type current

See also Functional Description of firmware "Automatic Setting of Motor Control"

C3603 - Attributes	Display:	C3603
	Ident N°:	C3603

10.2.236 C3604 Error when writing parameters (->S-0-0423)

Allocation	Contained in 02VRS:	«-»	«-»	«-»	
	Contained in 03VRS:	«MPB»	«MPH»	«MPD»	
	Contained in 04VRS:	«MPB»	«MPH»	«MPD»	
	Contained in 05VRS:	«MPB»	«MPH»	«MPD»	
	Contained in 06VRS:	«MPB»	«MPH»	«MPD»	«MPC»
	Contained in 07VRS:	«MPB»	«MPH»	«MPD»	«MPC»
	Contained in 08VRS:	«MPB»	«MPH»	«MPD»	«MPC»
	Supported by supply unit:	«-»			

When the command "P-0-0565, C3600 Command Motor data identification" was executed, the writing of at least one of the calculated parameters caused a limit error.

Cause	Remedy
Type plate data not entered correctly	Check values, correct them if necessary, then successively start "C3200 Command Calculate data for asynchronous motor" and "C3600 Command Motor data identification"

See also Functional Description of firmware "Automatic Setting of Motor Control"

C3604 - Attributes	Display:	C3604
	Ident N°:	C3604

Diagnostic Command Messages

10.2.239 C3607 Motor revolution/motion impeded

Allocation	Contained in 02VRS:	«-»	«-»	«-»	
	Contained in 03VRS:	«-»	«-»	«-»	
	Contained in 04VRS:	«-»	«-»	«-»	
	Contained in 05VRS:	«-»	«-»	«-»	
	Contained in 06VRS:	«-»	«-»	«-»	«-»
	Contained in 07VRS:	«-»	«-»	«-»	«-»
	Contained in 08VRS:	«MPB»	«MPH»	«MPD»	«MPC»
	Supported by supply unit:	«-»			

Command "P-0-0565, C3600 Command Motor data identification" was configured for a freely moving motor via "P-0-0601, Configuration motor data identification". It was aborted unsuccessfully because the motor could not be put into motion.

Cause	Remedy
Motor jammed because it is coupled to an axis/load	Check and enable mobility
Motor is not connected in delta	Check three-phase motor connection

See also Functional Description of firmware "Automatic Setting of Motor Control" or "Determining the Parameter Values of Third-Party Motors"

C3607 - Attributes
 Display: C3607
 Ident N°: C3607

10.2.240 C3608 Incorrect motor phases or rotational direction of encoder

Allocation	Contained in 02VRS:	«-»	«-»	«-»	
	Contained in 03VRS:	«-»	«-»	«-»	
	Contained in 04VRS:	«-»	«-»	«-»	
	Contained in 05VRS:	«-»	«-»	«-»	
	Contained in 06VRS:	«-»	«-»	«-»	«-»
	Contained in 07VRS:	«-»	«-»	«-»	«-»
	Contained in 08VRS:	«MPB»	«MPH»	«MPD»	«MPC»
	Supported by supply unit:	«-»			

Command "P-0-0565, C3600 Command Motor data identification" was aborted unsuccessfully because there was no validity of motor and motor encoder.

Cause	Remedy
2 motor phases interchanged	Exchange 2 motor phases
Sense of rotation of encoder is inverted as compared with sense of rotation of motor	Change sense of rotation of encoder using appropriate bit in "S-0-0277, Position feedback 1 type" - or - Exchange connection of encoder tracks. NOTE: Also check the properties with regard to the sense of rotation of the motor encoder gear if any is available.

See also Functional Description of firmware "Automatic Setting of Motor Control" or "Determining the Parameter Values of Third-Party Motors"

C3608 - Attributes
 Display: C3608
 Ident N°: C3608

Diagnostic Command Messages

10.2.243 C3611 Test velocity not reached

Allocation	Contained in 02VRS:	«-»	«-»	«-»	
	Contained in 03VRS:	«-»	«-»	«-»	
	Contained in 04VRS:	«-»	«-»	«-»	
	Contained in 05VRS:	«-»	«-»	«-»	
	Contained in 06VRS:	«-»	«-»	«-»	«-»
	Contained in 07VRS:	«-»	«-»	«-»	«-»
	Contained in 08VRS:	«MPB»	«MPH»	«MPD»	«MPC»
	Supported by supply unit:	«-»			

Command "P-0-0565, C3600 Command Motor data identification" was aborted because required test speed (half the nominal motor speed) could not be reached. The nominal speed related to the nominal voltage of the motor is too high.

Cause	Remedy
If supply is unregulated [HMV (type "E", feed), HCS]: Nominal motor voltage and speed are too high as compared with line voltage (requirement: $U_{\text{motor_nom}} < 150\% U_{\text{LN}}$).	If possible, adjust line voltage until requirement is met. Observe permitted line voltage range! - or - Reduce nominal motor data until requirement is met. Observe corresponding motor data (nominal speed, voltage, power)!
If supply is regulated [HMV (type "R", feedback)]: Nominal motor voltage and speed are too high as compared with maximum output voltage of controller (requirement: $U_{\text{motor_nom}} < 100\%$ DC voltage of DC bus).	Reduce nominal motor data until requirement is met. Observe corresponding motor data (nominal speed, voltage, power)!
Motor cannot follow drive-internal velocity command value. Acceleration ramp is too steep!	Flatten acceleration ramp by reducing P-0-0569 accordingly; ramp-up time should be at least 1 second. If synchronous motors fail to start nevertheless: Additionally increase value in P-0-0602!

See also Functional Description of firmware "Automatic Setting of Motor Control" or "Determining the Parameter Values of Third-Party Motors"

C3611 - Attributes	Display:	C3611
	Ident N°:	C3611

10.2.244 C3701 Error when manually unlocking the safety door

Allocation	Contained in 02VRS:	«MPB»	«MPH»	«MPD»	
	Contained in 03VRS:	«MPB»	«MPH»	«MPD»	
	Contained in 04VRS:	«MPB»	«MPH»	«MPD»	
	Contained in 05VRS:	«MPB»	«MPH»	«MPD»	
	Contained in 06VRS:	«MPB»	«MPH»	«MPD»	«MPC»
	Contained in 07VRS:	«MPB»	«MPH»	«MPD»	«MPC»
	Contained in 08VRS:	«MPB»	«MPH»	«MPD»	«MPC»
	Supported by supply unit:	«-»			

The command "C3700 Manually unlocking the safety door" was not or incorrectly executed.

Diagnostic Command Messages

Cause	Remedy
Drive still is in normal operation, there hasn't been any safety function activated yet - or - Drive is not in operating mode	Clear command "C3700 Manually unlocking the safety door". Select safety function via mode selector. Execute command again

See also documentation

- Up to MPx06: "Integrated Safety Technology"
- As of MPx07: "Integrated Safety Technology According to IEC61508"

C3701 - Attributes Display: C3701
 Ident N°: C3701

10.2.245 C3901 Resurfacing of holding brake only possible with drive enable

Allocation	Contained in 02VRS:	«MPB»	«MPH»	«MPD»	
	Contained in 03VRS:	«MPB»	«MPH»	«MPD»	
	Contained in 04VRS:	«MPB»	«MPH»	«MPD»	
	Contained in 05VRS:	«MPB»	«MPH»	«MPD»	
	Contained in 06VRS:	«MPB»	«MPH»	«MPD»	«MPC»
	Contained in 07VRS:	«MPB»	«MPH»	«MPD»	«MPC»
	Contained in 08VRS:	«MPB»	«MPH»	«MPD»	«MPC»
	Supported by supply unit:	«-»			

It is impossible to execute the command "P-0-0544, C3900 Command Abrasion of holding brake".

Cause	Remedy
Command was activated without drive enable ("AF") having been set	Switch drive to "AF", then start command "P-0-0544, C3900 Command Abrasion of holding brake"

See also Functional Description of firmware "Holding Brake"

C3901 - Attributes Display: C3901
 Ident N°: C3901

10.2.246 C3902 Error during resurfacing of holding brake

Allocation	Contained in 02VRS:	«MPB»	«MPH»	«MPD»	
	Contained in 03VRS:	«MPB»	«MPH»	«MPD»	
	Contained in 04VRS:	«MPB»	«MPH»	«MPD»	
	Contained in 05VRS:	«MPB»	«MPH»	«MPD»	
	Contained in 06VRS:	«MPB»	«MPH»	«MPD»	«MPC»
	Contained in 07VRS:	«MPB»	«MPH»	«MPD»	«MPC»
	Contained in 08VRS:	«MPB»	«MPH»	«MPD»	«MPC»
	Supported by supply unit:	«-»			

The execution of the command "P-0-0544, C3900 Command Abrasion of holding brake" was aborted by an error.

Cause	Remedy
Torque of amplifier is reduced	Remove reduction
Axis is mechanically blocked	Remove mechanical blocking
Axis is at end stop or runs towards it	Choose axis position such that sufficient motion is possible

Diagnostic Command Messages

Cause	Remedy
Resurfacing of brake is impossible, because motor generates less torque than holding torque of brake	Check whether there are torque limitations active in drive or whether controller has been sufficiently dimensioned
Sum of load due to weight and brake torque is greater than motor peak torque	Reduce load due to weight, if possible

See also Functional Description of firmware "Holding Brake"

C3902 - Attributes Display: C3902
 Ident N°: C3902

10.2.247 C3903 Command execution impossible

Allocation	Contained in 02VRS:	«MPB»	«MPH»	«MPD»	
	Contained in 03VRS:	«MPB»	«MPH»	«MPD»	
	Contained in 04VRS:	«MPB»	«MPH»	«MPD»	
	Contained in 05VRS:	«MPB»	«MPH»	«MPD»	
	Contained in 06VRS:	«MPB»	«MPH»	«MPD»	«MPC»
	Contained in 07VRS:	«MPB»	«MPH»	«MPD»	«MPC»
	Contained in 08VRS:	«MPB»	«MPH»	«MPD»	«MPC»
	Supported by supply unit:	«-»			

The command "P-0-0544, C3900 Command Holding brake resurfacing" could not be started.

Cause	Remedy
Brake control has not been activated in parameter "P-0-0525, Holding brake control word"	Activate brake control in parameter "P-0-0525, Holding brake control word"
Value in "P-0-0540, Torque of holding brake" is "0"	Enter correct value for "P-0-0540, Torque of holding brake"
Velocity limit value is too low to resurface holding brake	Value greater than or equal to 100 min ⁻¹ or 100 mm/min must be parameterized in S-0-0091

See also Functional Description of firmware "Holding Brake"

C3903 - Attributes Display: C3903
 Ident N°: C3903

10.2.248 C4001 Error during safe homing procedure

Allocation	Contained in 02VRS:	«MPB»	«MPH»	«MPD»	
	Contained in 03VRS:	«MPB»	«MPH»	«MPD»	
	Contained in 04VRS:	«MPB»	«MPH»	«MPD»	
	Contained in 05VRS:	«MPB»	«MPH»	«MPD»	
	Contained in 06VRS:	«MPB»	«MPH»	«MPD»	«MPC»
	Contained in 07VRS:	«MPB»	«MPH»	«MPD»	«MPC»
	Contained in 08VRS:	«MPB»	«MPH»	«MPD»	«MPC»
	Supported by supply unit:	«-»			

During the execution of the command "P-0-3228, C4000 Homing procedure command channel 2" an error occurred.



The command was not or incorrectly executed so that there is no safe reference or position.

Diagnostic Command Messages

Cause	Remedy
No home switch was configured for channel 2	Configure a home switch in "P-0-3211, Safety technology I/O configuration list, channel 2"
Actual position value difference between channel 1 and channel 2 is greater than value entered in "P-0-3229, Tolerance window for safe homing procedure"	Check parameter setting of "P-0-3229, Tolerance window for safe homing procedure" and "P-0-3231, Reference position for safe reference"
Failure on home switch input signal	Check wiring of home switch; check signal quality



In addition to troubleshooting, you have to reboot the drive; to do this, switch control voltage off and then on again.

See also documentation

- **Up to MPx06:** "Integrated Safety Technology"
- **As of MPx07:** "Integrated Safety Technology According to IEC61508"

C4001 - Attributes Display: C4001
 Ident N°: C4001

10.2.249 C4002 Incorrect distance of dedicated point channel 1-2

Allocation	Contained in 02VRS:	«MPB»	«MPH»	«MPD»	
	Contained in 03VRS:	«MPB»	«MPH»	«MPD»	
	Contained in 04VRS:	«MPB»	«MPH»	«MPD»	
	Contained in 05VRS:	«MPB»	«MPH»	«MPD»	
	Contained in 06VRS:	«MPB»	«MPH»	«MPD»	«MPC»
	Contained in 07VRS:	«MPB»	«MPH»	«MPD»	«MPC»
	Contained in 08VRS:	«MPB»	«MPH»	«MPD»	«MPC»
	Supported by supply unit:	«-»			

For encoders which without home switch do not have unequivocal reference to the axis position, a check is run at the beginning of command "P-0-3228, C4000 Homing procedure command channel 2" to find out whether the distance of the dedicated points of channel 1 and channel 2 is greater than the tolerance window plus a tolerance of 10 percent:

$$(S-0-0052/S-0-0054 - S-0-0150/S-0-0151 - P-0-3231) > (P-0-3229 * 1,1)$$

- S-0-0052 S-0-0052, Reference distance 1
- S-0-0054 S-0-0054, Reference distance 2
- S-0-0150 S-0-0150, Reference offset 1
- S-0-0151 S-0-0151, Reference offset 2
- P-0-3231 P-0-3231, Safety related reference position channel 2
- P-0-3229 P-0-3229, Tolerance window for safety related homing procedure

Fig. 10-5: Checking the distance of dedicated points of channel 1 and channel 2

This check allows detecting failures which are simultaneously taking effect on both reference inputs; incorrect position data reference can thereby be excluded.

10.2.252 C4103 Preselect parameter set forbidden value

Allocation	Contained in 02VRS:	«-»	«-»	«-»	
	Contained in 03VRS:	«MPB»	«MPH»	«-»	
	Contained in 04VRS:	«MPB»	«MPH»	«-»	
	Contained in 05VRS:	«MPB»	«MPH»	«-»	
	Contained in 06VRS:	«MPB»	«MPH»	«-»	«MPC»
	Contained in 07VRS:	«MPB»	«MPH»	«-»	«MPC»
	Contained in 08VRS:	«MPB»	«MPH»	«-»	«MPC»
	Supported by supply unit:	«-»			

"C4100 Switch parameter set command" couldn't be executed.

Cause	Remedy
Value entered in parameter "S-0-0217, Preselect parameter set command" is greater than value in "P-0-2217, Parameter set switching, preselection range"	Before starting "C4100 Switch parameter set command", set value in "S-0-0217, Preselect parameter set command" to valid value

See also Functional Description of firmware "Parameter Set Switching"

C4103 - Attributes	Display:	C4103
	Ident N°:	C4103

10.2.253 C4104 Error during parameter set switching (->S-0-0423)

Allocation	Contained in 02VRS:	«-»	«-»	«-»	
	Contained in 03VRS:	«-»	«-»	«-»	
	Contained in 04VRS:	«MPB»	«MPH»	«-»	
	Contained in 05VRS:	«MPB»	«MPH»	«-»	
	Contained in 06VRS:	«MPB»	«MPH»	«-»	«MPC»
	Contained in 07VRS:	«MPB»	«MPH»	«-»	«MPC»
	Contained in 08VRS:	«MPB»	«MPH»	«-»	«MPC»
	Supported by supply unit:	«-»			

"C4100 Switch parameter set command" could not be executed.

Cause	Remedy
A calculation error occurred during parameter set switching	IDN of parameter which caused error is displayed in "S-0-0423, IDN-list of invalid data for parameterization levels". Write valid value to displayed parameter

See also Functional Description of firmware "Parameter Set Switching"

C4104 - Attributes	Display:	C4104
	Ident N°:	C4104

10.2.254 C4201 Oscillation requires drive enable

Allocation	Contained in 02VRS:	«-»	«-»	«-»	
	Contained in 03VRS:	«MPB»	«MPH»	«-»	
	Contained in 04VRS:	«MPB»	«MPH»	«-»	
	Contained in 05VRS:	«MPB»	«MPH»	«-»	
	Contained in 06VRS:	«MPB»	«MPH»	«-»	«MPC»
	Contained in 07VRS:	«MPB»	«MPH»	«-»	«MPC»
	Contained in 08VRS:	«MPB»	«MPH»	«-»	«MPC»
	Supported by supply unit:	«-»			

During the execution of the command "S-0-0190, C4200 Drive-controlled oscillation command" an error was detected.

Diagnostic Command Messages

Cause	Remedy
At start of command, drive wasn't yet ready for power output	Before starting C4200 switch power on and set drive enable

See also Functional Description of firmware "Drive-Controlled Oscillation"

C4201 - Attributes **Display:** C4201
 Ident N°: C4201

10.2.255 C4202 Oscillation command speed cannot be reached

Allocation	Contained in 02VRS:	«-»	«-»	«-»	
	Contained in 03VRS:	«MPB»	«MPH»	«-»	
	Contained in 04VRS:	«MPB»	«MPH»	«-»	
	Contained in 05VRS:	«MPB»	«MPH»	«-»	
	Contained in 06VRS:	«MPB»	«MPH»	«-»	«MPC»
	Contained in 07VRS:	«MPB»	«MPH»	«-»	«MPC»
	Contained in 08VRS:	«MPB»	«MPH»	«-»	«MPC»
	Supported by supply unit:	«-»			

Five seconds after the start of "C4200 Drive-controlled oscillation command" the deviation of the actual velocity value from the oscillation start speed still is greater than or equal to the value of "S-0-0157, Velocity window".

Cause	Remedy
Value of "S-0-0157, Velocity window" is zero	Set "S-0-0157, Velocity window" to valid value greater zero
Motor is blocked or speed is too low due to high degree of friction	Check mechanical drive system for blocking or stiffness

See also Functional Description of firmware "Drive-Controlled Oscillation"

C4202 - Attributes **Display:** C4202
 Ident N°: C4202

10.2.256 C4302 Distance home switch - reference mark erroneous

Allocation	Contained in 02VRS:	«-»	«-»	«-»	
	Contained in 03VRS:	«MPB»	«MPH»	«MPD»	
	Contained in 04VRS:	«MPB»	«MPH»	«MPD»	
	Contained in 05VRS:	«MPB»	«MPH»	«MPD»	
	Contained in 06VRS:	«MPB»	«MPH»	«MPD»	«MPC»
	Contained in 07VRS:	«MPB»	«MPH»	«MPD»	«MPC»
	Contained in 08VRS:	«MPB»	«MPH»	«MPD»	«MPC»
	Supported by supply unit:	«-»			

During the execution of the command for NC-controlled homing (C4300) an error was detected.

The axis is equipped with a home switch connected to the controller (see settings for home switch and reference mark in "S-0-0147, Homing parameter").

Cause	Remedy
Distance between home switch edge and next reference mark determined by controller is not inside allowed range	Read value from parameter "S-0-0298, Reference cam shift" and take it over to parameter "S-0-0299, Home switch offset" - or - Shift reference cam by value of "S-0-0299, Home switch offset"

Diagnostic Command Messages

10.2.259 C4307 Reference cam input not assigned

Allocation	Contained in 02VRS:	«-»	«-»	«-»	
	Contained in 03VRS:	«MPB»	«MPH»	«MPD»	
	Contained in 04VRS:	«MPB»	«MPH»	«MPD»	
	Contained in 05VRS:	«MPB»	«MPH»	«MPD»	
	Contained in 06VRS:	«MPB»	«MPH»	«MPD»	«MPC»
	Contained in 07VRS:	«MPB»	«MPH»	«MPD»	«MPC»
	Contained in 08VRS:	«MPB»	«MPH»	«MPD»	«MPC»
	Supported by supply unit:	«-»			

During the execution of the command "S-0-0146, C4300 NC-controlled homing procedure command" an error was detected.

Cause	Remedy
Home switch hasn't been assigned to any digital input	Assign home switch ("S-0-0400, Home switch") to a digital input via parameter "P-0-0300, Digital I/Os, assignment list"
Home switch was connected to NC but "S-0-0147, Homing parameter" was incorrectly parameterized	Correct setting of respective bit of "S-0-0147, Homing parameter"

See also Functional Description of firmware "Establishing Position Data Reference for Relative Measuring Systems"

C4307 - Attributes	Display:	C4307
	Ident N°:	C4307

10.2.260 C4308 Pos. stop a. HW lim. switch not allowed f. modulo axes

Allocation	Contained in 02VRS:	«-»	«-»	«-»	
	Contained in 03VRS:	«MPB»	«MPH»	«MPD»	
	Contained in 04VRS:	«MPB»	«MPH»	«MPD»	
	Contained in 05VRS:	«MPB»	«MPH»	«MPD»	
	Contained in 06VRS:	«MPB»	«MPH»	«MPD»	«MPC»
	Contained in 07VRS:	«MPB»	«MPH»	«MPD»	«MPC»
	Contained in 08VRS:	«MPB»	«MPH»	«MPD»	«MPC»
	Supported by supply unit:	«-»			

During the execution of the command for NC-controlled homing (C4300) an error was detected:

Cause	Remedy
NC-controlled homing at positive stop or travel range limit switch with modulo axes isn't a useful combination and therefore not allowed!	Modify control information for homing in "S-0-0147, Homing parameter" in a useful way

C4308 - Attributes	Display:	C4308
	Ident N°:	C4308

10.2.261 C4601 Error when writing parameters (->S-0-0423)

Allocation	Contained in 02VRS:	«-»	«-»	«-»	
	Contained in 03VRS:	«MPB»	«MPH»	«MPD»	
	Contained in 04VRS:	«MPB»	«MPH»	«MPD»	
	Contained in 05VRS:	«MPB»	«MPH»	«MPD»	
	Contained in 06VRS:	«MPB»	«MPH»	«MPD»	«MPC»
	Contained in 07VRS:	«MPB»	«MPH»	«MPD»	«MPC»
	Contained in 08VRS:	«MPB»	«MPH»	«MPD»	«MPC»
	Supported by supply unit:	«-»			

Diagnostic Command Messages

Cause	Remedy
Position command value characteristic preset by control master has caused too high measuring velocity at motor	Check position command value characteristic of control master and, if necessary, reduce time-related position command value increase; take possibly existing gear ratio into account. Note: Values in table 1 always refer to motor shaft!

C4801 - Attributes Display: C4801
 Ident N°: C4801

10.2.264 C4802 Cogging torque compensation: Measuring vel. too low

Allocation	Contained in 02VRS:	«-»	«-»	«-»	
	Contained in 03VRS:	«-»	«-»	«-»	
	Contained in 04VRS:	«-»	«MPH»	«MPD»	
	Contained in 05VRS:	«-»	«MPH»	«MPD»	
	Contained in 06VRS:	«-»	«MPH»	«MPD»	«MPC»
	Contained in 07VRS:	«-»	«MPH»	«MPD»	«MPC»
	Contained in 08VRS:	«-»	«MPH»	«MPD»	«MPC»
	Supported by supply unit:	«-»			

An error occurred during the execution of the command "P-0-1138, C4800 Command Determine cogging torque compensation table".

Cause	Remedy
Position command value characteristic preset by control master has caused too low measuring velocity at motor	Check position command value characteristic of control master and, if necessary, increase time-related position command value increase; take possibly existing gear ratio into account. Note: Values in table 1 always refer to motor shaft!

C4802 - Attributes Display: C4802
 Ident N°: C4802

10.2.265 C4803 Cogging torque compensation: Inadmissible acceleration

Allocation	Contained in 02VRS:	«-»	«-»	«-»	
	Contained in 03VRS:	«-»	«-»	«-»	
	Contained in 04VRS:	«-»	«MPH»	«MPD»	
	Contained in 05VRS:	«-»	«MPH»	«MPD»	
	Contained in 06VRS:	«-»	«MPH»	«MPD»	«MPC»
	Contained in 07VRS:	«-»	«MPH»	«MPD»	«MPC»
	Contained in 08VRS:	«-»	«MPH»	«MPD»	«MPC»
	Supported by supply unit:	«-»			

An error occurred during the execution of the command "P-0-1138, C4800 Command Determine cogging torque compensation table".

Cause	Remedy
Position command value characteristic preset by control master has caused too high acceleration during measured value detection for cogging torque/force compensation	Check position command value characteristic of control master and, if necessary, change it in such a way that motor moves with constant velocity in measured value detection range (see "P-0-1133, Status word of cogging torque compensation")

C4803 - Attributes Display: C4803
 Ident N°: C4803

10.2.266 C4804 Cogging torque comp.: Err. when storing corr. val table

Allocation	Contained in 02VRS:	«-»	«-»	«-»	
	Contained in 03VRS:	«-»	«-»	«-»	
	Contained in 04VRS:	«-»	«MPH»	«MPD»	
	Contained in 05VRS:	«-»	«MPH»	«MPD»	
	Contained in 06VRS:	«-»	«MPH»	«MPD»	«MPC»
	Contained in 07VRS:	«-»	«MPH»	«MPD»	«MPC»
	Contained in 08VRS:	«-»	«MPH»	«MPD»	«MPC»
	Supported by supply unit:	«-»			

An error occurred during the execution of the command "P-0-1138, C4800 Command Determine cogging torque compensation table".

Cause	Remedy
Active non-volatile memory couldn't be addressed without error	Restart "P-0-1138, C4800 Command Determine cogging torque compensation table"; should error occur repeatedly, please contact our service department

C4804 - Attributes Display: C4804
 Ident N°: C4804

10.2.267 C4805 Cogging torque comp.: Motor measuring system not homed

Allocation	Contained in 02VRS:	«-»	«-»	«-»	
	Contained in 03VRS:	«-»	«-»	«-»	
	Contained in 04VRS:	«-»	«MPH»	«MPD»	
	Contained in 05VRS:	«-»	«MPH»	«MPD»	
	Contained in 06VRS:	«-»	«MPH»	«MPD»	«MPC»
	Contained in 07VRS:	«-»	«MPH»	«MPD»	«MPC»
	Contained in 08VRS:	«-»	«MPH»	«MPD»	«MPC»
	Supported by supply unit:	«-»			

An error occurred during the execution of the command "P-0-1138, C4800 Command Determine cogging torque compensation table".

Cause	Remedy
Motor encoder (relative) of a rotary motor didn't yet have position data reference	Before starting command "P-0-1138, C4800 Command Determine cogging torque compensation table", make motor turn until reference mark of motor encoder is read
Motor encoder (relative) of a linear motor didn't yet have position data reference	Before starting command "P-0-1138, C4800 Command Determine cogging torque compensation table", establish position data reference

See also Functional Description of firmware "Establishing Position Data Reference for Relative Measuring Systems"

C4805 - Attributes Display: C4805
 Ident N°: C4805

Diagnostic Command Messages

10.2.268 C4901 PLC command error no. 1

Allocation	Contained in 02VRS:	«-»	«-»	«-»	
	Contained in 03VRS:	«-»	«-»	«-»	
	Contained in 04VRS:	«MPB»	«MPH»	«-»	
	Contained in 05VRS:	«MPB»	«MPH»	«-»	
	Contained in 06VRS:	«MPB»	«MPH»	«-»	«MPC»
	Contained in 07VRS:	«MPB»	«MPH»	«-»	«MPC»
	Contained in 08VRS:	«MPB»	«MPH»	«-»	«MPC»
	Supported by supply unit:	«-»			

The command "P-0-1449, C4900 PLC command" for controlling a PLC program was started.

Cause	Remedy
PLC program has generated "PLC command error no. 1"	See program description of PLC program for how to react to C4901

See also Application Manual "Rexroth IndraMotion MLD"

C4901 - Attributes	Display:	C4901
	Ident N°:	C4901

10.2.269 C4902 PLC command error no. 2

Allocation	Contained in 02VRS:	«-»	«-»	«-»	
	Contained in 03VRS:	«-»	«-»	«-»	
	Contained in 04VRS:	«MPB»	«MPH»	«-»	
	Contained in 05VRS:	«MPB»	«MPH»	«-»	
	Contained in 06VRS:	«MPB»	«MPH»	«-»	«MPC»
	Contained in 07VRS:	«MPB»	«MPH»	«-»	«MPC»
	Contained in 08VRS:	«MPB»	«MPH»	«-»	«MPC»
	Supported by supply unit:	«-»			

The command "P-0-1449, C4900 PLC command" for controlling a PLC program was started.

Cause	Remedy
PLC program has generated "PLC command error no. 2"	See program description of PLC program for how to react to C4902

See also Application Manual "Rexroth IndraMotion MLD"

C4902 - Attributes	Display:	C4902
	Ident N°:	C4902

10.2.270 C4903 PLC command error no. 3

Allocation	Contained in 02VRS:	«-»	«-»	«-»	
	Contained in 03VRS:	«-»	«-»	«-»	
	Contained in 04VRS:	«MPB»	«MPH»	«-»	
	Contained in 05VRS:	«MPB»	«MPH»	«-»	
	Contained in 06VRS:	«MPB»	«MPH»	«-»	«MPC»
	Contained in 07VRS:	«MPB»	«MPH»	«-»	«MPC»
	Contained in 08VRS:	«MPB»	«MPH»	«-»	«MPC»
	Supported by supply unit:	«-»			

The command "P-0-1449, C4900 PLC command" for controlling a PLC program was started.

Diagnostic Command Messages

10.2.273 C5301 SERCOS III: Delay measurement failed

Allocation	Contained in 02VRS:	«-»	«-»	«-»
	Contained in 03VRS:	«-»	«-»	«-»
	Contained in 04VRS:	«-»	«-»	«-»
	Contained in 05VRS:	«-»	«-»	«-»
	Contained in 06VRS:	«MPB»	«MPH»	«MPD» «MPC»
	Contained in 07VRS:	«MPB»	«MPH»	«MPD» «MPC»
	Contained in 08VRS:	«MPB»	«MPH»	«MPD» «MPC»
	Supported by supply unit:	«-»		

During the execution of the command "S-0-1024, C5300 SERCOS III: SYNC delay measuring procedure command" an error occurred or the command could not be started.

Cause	Remedy
Parameterization for execution of command is incomplete; measurement cannot be started	Enter valid value in "S-0-1015, SERCOS III: Ring delay"
Measurement was unsuitable, because deviations in measured values were too big	Repeat measurement
Measurement was unsuitable, because topology changed during measuring process	Repeat measurement

C5301 - Attributes Display: C5301
 Ident N°: C5301

10.2.274 C5401 PLC program not ready for retain data backup

Allocation	Contained in 02VRS:	«-»	«-»	«-»
	Contained in 03VRS:	«-»	«-»	«-»
	Contained in 04VRS:	«MPB»	«MPH»	«-»
	Contained in 05VRS:	«MPB»	«MPH»	«-»
	Contained in 06VRS:	«MPB»	«MPH»	«-» «MPC»
	Contained in 07VRS:	«MPB»	«MPH»	«-» «MPC»
	Contained in 08VRS:	«MPB»	«MPH»	«-» «MPC»
	Supported by supply unit:	«-»		

During the execution of the command "P-0-4054, C5400 Command Save PLC retain data on MMC" an error occurred.

Cause	Remedy
No PLC program has been loaded (cf. "P-0-1351, PLC status word")	Check PLC programs (load them, if necessary) and then start "P-0-4054, C5400 Command Save PLC retain data on MMC"



The MMC is an optional component of the control section.

C5401 - Attributes Display: C5401
 Ident N°: C5401

10.2.275 C5402 Error when writing data to the MMC

Allocation	Contained in 02VRS:	«-»	«-»	«-»	
	Contained in 03VRS:	«-»	«-»	«-»	
	Contained in 04VRS:	«MPB»	«MPH»	«-»	
	Contained in 05VRS:	«MPB»	«MPH»	«-»	
	Contained in 06VRS:	«MPB»	«MPH»	«-»	«MPC»
	Contained in 07VRS:	«MPB»	«MPH»	«-»	«MPC»
	Contained in 08VRS:	«MPB»	«MPH»	«-»	«MPC»
	Supported by supply unit:	«-»			

During the execution of the command "P-0-4054, C5400 Command Save PLC retain data on MMC" an error occurred.

Cause	Remedy
MMC (MultiMediaCard) has not been plugged	Plug MMC into controller and then start "P-0-4054, C5400 Command Save PLC retain data on MMC"
MMC (MultiMediaCard) was not formatted correctly	Start command "P-0-4072, C2900 Command Firmware update from MMC" and then "P-0-4054, C5400 Command Save PLC retain data on MMC"

 The MMC is an optional component of the control section.

C5402 - Attributes Display: C5402
 Ident N°: C5402

10.2.276 C5501 PLC program not ready for loading retain data

Allocation	Contained in 02VRS:	«-»	«-»	«-»	
	Contained in 03VRS:	«-»	«-»	«-»	
	Contained in 04VRS:	«MPB»	«MPH»	«-»	
	Contained in 05VRS:	«MPB»	«MPH»	«-»	
	Contained in 06VRS:	«MPB»	«MPH»	«-»	«MPC»
	Contained in 07VRS:	«MPB»	«MPH»	«-»	«MPC»
	Contained in 08VRS:	«MPB»	«MPH»	«-»	«MPC»
	Supported by supply unit:	«-»			

While command "P-0-4055, C5500 Command Load PLC retain data from MMC" was executed, an error occurred.

Cause	Remedy
No PLC boot project has been loaded (cf. "P-0-1351, PLC status word")	Command C55 can only be executed if PLC boot project loaded is appropriate for retain data. Check PLC boot project (load it, if necessary) and then start "P-0-4055, C5500 Command Load PLC retain data from MMC"
PLC program is still active (cf. "P-0-1351, PLC status word")	Stop PLC program and then start "P-0-4055, C5500 Command Load PLC retain data from MMC"

 The MMC is an optional component of the control section.

C5501 - Attributes Display: C5501
 Ident N°: C5501

Diagnostic Command Messages

10.2.277 C5502 MMC not available or not OK

Allocation	Contained in 02VRS:	«-»	«-»	«-»	
	Contained in 03VRS:	«-»	«-»	«-»	
	Contained in 04VRS:	«MPB»	«MPH»	«-»	
	Contained in 05VRS:	«MPB»	«MPH»	«-»	
	Contained in 06VRS:	«MPB»	«MPH»	«-»	«MPC»
	Contained in 07VRS:	«MPB»	«MPH»	«-»	«MPC»
	Contained in 08VRS:	«MPB»	«MPH»	«-»	«MPC»
	Supported by supply unit:	«-»			

During the execution of the command "P-0-4055, C5500 Command Load PLC retain data from MMC" an error occurred.

Cause	Remedy
MMC (MultiMediaCard) has not been plugged	Plug MMC into controller and then start "P-0-4055, C5500 Command Load PLC retain data from MMC"
MMC (MultiMediaCard) was not formatted correctly	Start command "P-0-4072, C2900 Command Firmware update from MMC" and then "P-0-4055, C5500 Command Load PLC retain data from MMC"



The MMC is an optional component of the control section.

C5502 - Attributes	Display:	C5502
	Ident N°:	C5502

10.2.278 C5503 PLC retain data do not match PLC program

Allocation	Contained in 02VRS:	«-»	«-»	«-»	
	Contained in 03VRS:	«-»	«-»	«-»	
	Contained in 04VRS:	«MPB»	«MPH»	«-»	
	Contained in 05VRS:	«MPB»	«MPH»	«-»	
	Contained in 06VRS:	«MPB»	«MPH»	«-»	«MPC»
	Contained in 07VRS:	«MPB»	«MPH»	«-»	«MPC»
	Contained in 08VRS:	«MPB»	«MPH»	«-»	«MPC»
	Supported by supply unit:	«-»			

During the execution of the command "P-0-4055, C5500 Command Load PLC retain data from MMC" an error occurred.

Cause	Remedy
PLC retain data on MMC do not match currently running PLC program (see "P-0-1360, PLC program identifier")	Plug appropriate MMC into controller and then start "P-0-4055, C5500 Command Load PLC retain data from MMC" - or - Load appropriate PLC program and then start "P-0-4055, C5500 Command Load PLC retain data from MMC"



The MMC is an optional component of the control section.

C5503 - Attributes	Display:	C5503
	Ident N°:	C5503

10.2.279 C5504 Unknown format in PLC retain file

Allocation	Contained in 02VRS:	«-»	«-»	«-»	
	Contained in 03VRS:	«-»	«-»	«-»	
	Contained in 04VRS:	«MPB»	«MPH»	«-»	
	Contained in 05VRS:	«MPB»	«MPH»	«-»	
	Contained in 06VRS:	«MPB»	«MPH»	«-»	«MPC»
	Contained in 07VRS:	«MPB»	«MPH»	«-»	«MPC»
	Contained in 08VRS:	«MPB»	«MPH»	«-»	«MPC»
	Supported by supply unit:	«-»			

During the execution of the command "P-0-4055, C5500 Command Load PLC retain data from MMC" an error occurred.

Cause	Remedy
File "SPS-Retain.pbf" has unknown format	Load appropriate firmware to controller and then start "P-0-4055, C5500 Command Load PLC retain data from MMC"



The MMC is an optional component of the control section.

C5504 - Attributes Display: C5504
 Ident N°: C5504

10.2.280 C5505 Invalid PLC retain data

Allocation	Contained in 02VRS:	«-»	«-»	«-»	
	Contained in 03VRS:	«-»	«-»	«-»	
	Contained in 04VRS:	«MPB»	«MPH»	«-»	
	Contained in 05VRS:	«MPB»	«MPH»	«-»	
	Contained in 06VRS:	«MPB»	«MPH»	«-»	«MPC»
	Contained in 07VRS:	«MPB»	«MPH»	«-»	«MPC»
	Contained in 08VRS:	«MPB»	«MPH»	«-»	«MPC»
	Supported by supply unit:	«-»			

During the execution of the command "P-0-4055, C5500 Command Load PLC retain data from MMC" an error occurred.

Cause	Remedy
Stored PLC retain data in file "SPS-Retain.pbf" are invalid	Again generate file "SPS-Retain.pbf" with "P-0-4054, C5400 Command Save PLC retain data on MMC" and then start "P-0-4055, C5500 Command Load PLC retain data from MMC"



The MMC is an optional component of the control section.

C5505 - Attributes Display: C5505
 Ident N°: C5505

Diagnostic Command Messages

10.2.281 C5601 Command requires drive enable

Allocation	Contained in 02VRS:	«-»	«-»	«-»	
	Contained in 03VRS:	«-»	«-»	«-»	
	Contained in 04VRS:	«MPB»	«MPH»	«MPD»	
	Contained in 05VRS:	«MPB»	«MPH»	«MPD»	
	Contained in 06VRS:	«MPB»	«MPH»	«MPD»	«MPC»
	Contained in 07VRS:	«MPB»	«MPH»	«MPD»	«MPC»
	Contained in 08VRS:	«MPB»	«MPH»	«MPD»	«MPC»
	Supported by supply unit:	«-»			

During the execution of the "P-0-0518, C5600 Command subsequent optimization of commutation offset" an error occurred.

Cause	Remedy
Command for subsequent optimization of commutation offset setting was started, but drive is not in "AF"	Switch drive to "AF" and then restart command "P-0-0518, C5600 Command subsequent optimization of commutation offset"

See also Functional Description of firmware "Commutation Setting"

C5601 - Attributes	Display:	C5601
	Ident N°:	C5601

10.2.282 C5602 Axis blocked

Allocation	Contained in 02VRS:	«-»	«-»	«-»	
	Contained in 03VRS:	«-»	«-»	«-»	
	Contained in 04VRS:	«MPB»	«MPH»	«MPD»	
	Contained in 05VRS:	«MPB»	«MPH»	«MPD»	
	Contained in 06VRS:	«MPB»	«MPH»	«MPD»	«MPC»
	Contained in 07VRS:	«MPB»	«MPH»	«MPD»	«MPC»
	Contained in 08VRS:	«MPB»	«MPH»	«MPD»	«MPC»
	Supported by supply unit:	«-»			

During the execution of the "P-0-0518, C5600 Command subsequent optimization of commutation offset" an error occurred.

Cause	Remedy
To successfully carry out command for subsequent optimization of commutation offset setting, motor/axis must be able to freely move by some degrees; this is not the case	Remove axis blocking and then restart command "P-0-0518, C5600 Command subsequent optimization of commutation offset"

See also Functional Description of firmware "Commutation Setting"

C5602 - Attributes	Display:	C5602
	Ident N°:	C5602

10.2.283 C5603 Timeout: Axis in motion

Allocation	Contained in 02VRS:	«-»	«-»	«-»	
	Contained in 03VRS:	«-»	«-»	«-»	
	Contained in 04VRS:	«MPB»	«MPH»	«MPD»	
	Contained in 05VRS:	«MPB»	«MPH»	«MPD»	
	Contained in 06VRS:	«MPB»	«MPH»	«MPD»	«MPC»
	Contained in 07VRS:	«MPB»	«MPH»	«MPD»	«MPC»
	Contained in 08VRS:	«MPB»	«MPH»	«MPD»	«MPC»
	Supported by supply unit:	«-»			

Diagnostic Command Messages

During the execution of the command "P-0-0518, C5600 Command subsequent optimization of commutation offset", the axis must have stopped or after motion triggered by the execution of the command, the axis must come to standstill again. If this is impossible, the command is aborted.

Cause	Remedy
External motion mechanically coupled	Remove external motion; uncouple motor, if necessary
Axis has very long post-pulse oscillation	Reduce oscillation time of axis, generate slight additional friction at axis, if necessary

See also Functional Description of firmware "Commutation Setting"

C5603 - Attributes Display: C5603
 Ident N°: C5603

10.2.284 C5801 Command Apply redundant holding brake not possible

Allocation	Contained in 02VRS:	«-»	«-»	«-»	
	Contained in 03VRS:	«-»	«-»	«-»	
	Contained in 04VRS:	«MPB»	«MPH»	«MPD»	
	Contained in 05VRS:	«MPB»	«MPH»	«MPD»	
	Contained in 06VRS:	«MPB»	«MPH»	«MPD»	«MPC»
	Contained in 07VRS:	«MPB»	«MPH»	«MPD»	«MPC»
	Contained in 08VRS:	«MPB»	«MPH»	«MPD»	«MPC»
Supported by supply unit:	«-»				

The execution of the command "P-0-3313, C5800 Command Apply redundant holding brake" was aborted by an error.

Cause	Remedy
Channel 2 of safety technology prevented redundant holding brake from applying	Parameterize channel 2 of safety technology in such a way that execution of command "P-0-3313, C5800 Command Apply redundant holding brake" is allowed

C5801 - Attributes Display: C5801
 Ident N°: C5801

10.2.285 C5901 Comm. Resurfacing of red. holding brake only possible AF

Allocation	Contained in 02VRS:	«-»	«-»	«-»	
	Contained in 03VRS:	«-»	«-»	«-»	
	Contained in 04VRS:	«MPB»	«MPH»	«MPD»	
	Contained in 05VRS:	«MPB»	«MPH»	«MPD»	
	Contained in 06VRS:	«MPB»	«MPH»	«MPD»	«MPC»
	Contained in 07VRS:	«MPB»	«MPH»	«MPD»	«MPC»
	Contained in 08VRS:	«MPB»	«MPH»	«MPD»	«MPC»
Supported by supply unit:	«-»				

Executing command "P-0-3314, C5900 Command Resurfacing of redundant holding brake" is impossible.

Cause	Remedy
Command "P-0-3314, C5900 Command Resurfacing of redundant holding brake" was activated without drive enable ("AF") having been set	Clear command error, switch drive to "AF" and then start command "P-0-3314, C5900 Command Resurfacing of redundant holding brake"

See also Functional Description of firmware "Motor Holding Brake"

Diagnostic Command Messages

C5901 - Attributes **Display:** C5901
Ident N°: C5901

10.2.286 C5902 Error when resurfacing redundant holding brake

Allocation	Contained in 02VRS:	«-»	«-»	«-»	
	Contained in 03VRS:	«-»	«-»	«-»	
	Contained in 04VRS:	«MPB»	«MPH»	«MPD»	
	Contained in 05VRS:	«MPB»	«MPH»	«MPD»	
	Contained in 06VRS:	«MPB»	«MPH»	«MPD»	«MPC»
	Contained in 07VRS:	«MPB»	«MPH»	«MPD»	«MPC»
	Contained in 08VRS:	«MPB»	«MPH»	«MPD»	«MPC»
	Supported by supply unit:	«-»			

The execution of the command "P-0-3314, C5900 Command Resurfacing of redundant holding brake" was aborted by an error.

Cause	Remedy
Torque of amplifier is reduced	Remove reduction
Axis is mechanically blocked	Remove mechanical blocking
Axis is at end stop or runs towards it	Choose axis position such that sufficient motion is possible
Resurfacing of brake is impossible because motor generates less torque than holding torque of brake	Check whether there are torque limitations active in drive or whether controller has been sufficiently dimensioned
Sum of load due to weight and brake torque is greater than motor peak torque	Reduce load due to weight, if possible

See also Functional Description of firmware "Motor Holding Brake"

C5902 - Attributes **Display:** C5902
Ident N°: C5902

10.2.287 C5903 Command execution impossible

Allocation	Contained in 02VRS:	«-»	«-»	«-»	
	Contained in 03VRS:	«-»	«-»	«-»	
	Contained in 04VRS:	«MPB»	«MPH»	«MPD»	
	Contained in 05VRS:	«MPB»	«MPH»	«MPD»	
	Contained in 06VRS:	«MPB»	«MPH»	«MPD»	«MPC»
	Contained in 07VRS:	«MPB»	«MPH»	«MPD»	«MPC»
	Contained in 08VRS:	«MPB»	«MPH»	«MPD»	«MPC»
	Supported by supply unit:	«-»			

It is impossible to execute the command "P-0-3314, C5900 Command Resurfacing of redundant holding brake".

Cause	Remedy
Brake control has not been activated	Activate brake control in parameter is "P-0-3300, Redundant holding brake: Configuration"
A form-fitting holding brake is configured	Command "P-0-3314, C5900 Command Resurfacing of redundant holding brake" can only be executed with friction-fitting holding brakes.
Safety technology prevents command from being executed because drive is in special mode	Switch to normal operation

See also Functional Description of firmware "Motor Holding Brake"

Diagnostic Command Messages

10.2.290 C6003 Absolute encoder offset cannot be saved

Allocation	Contained in 02VRS:	«-»	«-»	«-»	
	Contained in 03VRS:	«-»	«-»	«-»	
	Contained in 04VRS:	«MPB»	«MPH»	«MPD»	
	Contained in 05VRS:	«MPB»	«MPH»	«MPD»	
	Contained in 06VRS:	«MPB»	«MPH»	«MPD»	«MPC»
	Contained in 07VRS:	«MPB»	«MPH»	«MPD»	«MPC»
	Contained in 08VRS:	«MPB»	«MPH»	«MPD»	«MPC»
	Supported by supply unit:	«-»			

When executing the command for setting absolute measuring (C6000) the offset of the encoder zero point with regard to the machine zero point is determined and stored in the data memory of the encoder. It was impossible to store the offset correctly.

Cause	Remedy
Communication between encoder and drive is disturbed	Check encoder cable and repair it, if necessary - or - Replace encoder

C6003 - Attributes **Display:** C6003
Ident N°: C6003

10.2.291 C6004 Command cannot be executed under drive enable

Allocation	Contained in 02VRS:	«-»	«-»	«-»	
	Contained in 03VRS:	«-»	«-»	«-»	
	Contained in 04VRS:	«MPB»	«MPH»	«MPD»	
	Contained in 05VRS:	«MPB»	«MPH»	«MPD»	
	Contained in 06VRS:	«MPB»	«MPH»	«MPD»	«MPC»
	Contained in 07VRS:	«MPB»	«MPH»	«MPD»	«MPC»
	Contained in 08VRS:	«MPB»	«MPH»	«MPD»	«MPC»
	Supported by supply unit:	«-»			

Cause	Remedy
Command "C6000 Command Set absolute measuring" was started with drive enable having been activated; in first stage of expansion of function "set absolute measuring" according to SERCOS specification, this is not supported	Reset drive enable, then clear command error and restart command "C6000 Command Set absolute measuring"

C6004 - Attributes **Display:** C6004
Ident N°: C6004

10.2.292 C6101 Incorrect IP settings

Allocation	Contained in 02VRS:	«-»	«-»	«-»	
	Contained in 03VRS:	«-»	«-»	«-»	
	Contained in 04VRS:	«-»	«-»	«-»	
	Contained in 05VRS:	«MPB»	«MPH»	«MPD»	
	Contained in 06VRS:	«MPB»	«MPH»	«MPD»	«MPC»
	Contained in 07VRS:	«MPB»	«MPH»	«MPD»	«MPC»
	Contained in 08VRS:	«MPB»	«MPH»	«MPD»	«MPC»
	Supported by supply unit:	«-»			

During the execution of the command "P-0-1534, C6100 Command Activate IP settings", the settings made by the user are checked.

Diagnostic Command Messages

10.2.294 C6401 reboot command impossible

Allocation	Contained in 02VRS:	«-»	«-»	«-»	
	Contained in 03VRS:	«-»	«-»	«-»	
	Contained in 04VRS:	«-»	«-»	«-»	
	Contained in 05VRS:	«-»	«-»	«-»	
	Contained in 06VRS:	«-»	«-»	«-»	«-»
	Contained in 07VRS:	«-»	«-»	«-»	«-»
	Contained in 08VRS:	«MPB»	«MPH»	«MPD»	«MPC»
	Supported by supply unit:	«-»			

While command "S-0-1350, C6400 reboot command" was executed, an error occurred.

Cause	Remedy
At least one axis of multi-axis device fails to be in "PM"	<ol style="list-style-type: none"> 1. Reset command 2. Switch all axes of multi-axis device to "PM" 3. Restart command

C6401 - Attributes Display: C6401
 Ident N°: C6401

10.2.295 C6501 Error when writing backup data (backup memory)

Allocation	Contained in 02VRS:	«-»	«-»	«-»	
	Contained in 03VRS:	«-»	«-»	«-»	
	Contained in 04VRS:	«-»	«-»	«-»	
	Contained in 05VRS:	«-»	«-»	«-»	
	Contained in 06VRS:	«-»	«-»	«-»	«MPC»
	Contained in 07VRS:	«-»	«-»	«-»	«MPC»
	Contained in 08VRS:	«-»	«-»	«-»	«MPC»
	Supported by supply unit:	«-»			

During the execution of the command C6500, an error occurred when the backup data had been written to the MultiMediaCard (MMC).



The parameter backup is incomplete or faulty!



See the file "Backup.log" for the parameters which were successfully backed up and for the parameters with which an error occurred during backup; "Backup.log" is contained in the directory "User/Backup" on the MMC.

Cause	Remedy
Not enough available memory space on MMC	Use MMC with more memory space or delete unrequired files from MMC, then execute command C6500 again
MMC was not or not correctly formatted	Format MMC and execute command C6500 again. Notes: Directory "user" must exist on MMC. When MMC is formatted, all data stored on MMC are lost.
MMC has not (or not completely) been plugged in MMC slot provided for this purpose	Plug MMC in controller and execute command C6500 again

Diagnostic Command Messages

Cause	Remedy
MMC is defective	Check MMC and execute command C6500 again If diagnostic message is displayed repeatedly: Replace MMC
MMC slot in control section is defective	Check MMC slot and, if necessary, replace control section or entire drive controller



Only Rexroth service engineers or especially trained users are allowed to replace the control section. The replacement of the entire drive controller is described in the Project Planning Manual for the power section.

See also Functional Description of firmware "MultiMediaCard (MMC)"

C6501 - Attributes Display: C6501
 Ident N°: C6501

10.2.296 C6502 Error when reading backup data (device)

Allocation	Contained in 02VRS:	«-»	«-»	«-»	
	Contained in 03VRS:	«-»	«-»	«-»	
	Contained in 04VRS:	«-»	«-»	«-»	
	Contained in 05VRS:	«-»	«-»	«-»	
	Contained in 06VRS:	«-»	«-»	«-»	«MPC»
	Contained in 07VRS:	«-»	«-»	«-»	«MPC»
	Contained in 08VRS:	«-»	«-»	«-»	«MPC»
	Supported by supply unit:	«-»			

During the execution of the command C6500, an error occurred when a parameter in the active, non-volatile memory of the drive controller or a CCD slave had been read.



The parameter backup is incomplete or faulty!



See the file "user/Backup/Backup.log" for the parameters which were successfully backed up and for the parameters with which an error occurred.

Cause	Remedy
Incorrect parameter access to a CCD slave	Check cross communication (CCD) and execute command C6500 again

C6502 - Attributes Display: C6502
 Ident N°: C6502

Diagnostic Command Messages

10.2.297 C6503 Error when checking backup data (comparison)

Allocation	Contained in 02VRS:	«-»	«-»	«-»	
	Contained in 03VRS:	«-»	«-»	«-»	
	Contained in 04VRS:	«-»	«-»	«-»	
	Contained in 05VRS:	«-»	«-»	«-»	
	Contained in 06VRS:	«-»	«-»	«-»	«MPC»
	Contained in 07VRS:	«-»	«-»	«-»	«MPC»
	Contained in 08VRS:	«-»	«-»	«-»	«MPC»
	Supported by supply unit:	«-»			

The command C6500 was terminated with error. The comparative data are different.

To verify the backup parameters, the comparative data at the beginning of backup are compared to the comparative data upon completed backup. These data must be identical. Otherwise, the value of one or several parameters changed while the command had been active.



The parameter backup might possibly be inconsistent!

Cause	Remedy
Write access to one or several parameters during backup procedure	Execute command C6500 again



The comparative value S-0-0531 temporarily changes with PLC program active, because the PLC program is stopped while the command C6500 is active.

C6503 - Attributes	Display:	C6503
	Ident N°:	C6503

10.2.298 C6601 Error when reading backup data (backup memory)

Allocation	Contained in 02VRS:	«-»	«-»	«-»	
	Contained in 03VRS:	«-»	«-»	«-»	
	Contained in 04VRS:	«-»	«-»	«-»	
	Contained in 05VRS:	«-»	«-»	«-»	
	Contained in 06VRS:	«-»	«-»	«-»	«MPC»
	Contained in 07VRS:	«-»	«-»	«-»	«MPC»
	Contained in 08VRS:	«-»	«-»	«-»	«MPC»
	Supported by supply unit:	«-»			

During the execution of the command C6600, an error occurred when the backup data had been read on the MultiMediaCard (MMC).



The restored parameters are incomplete or faulty!



See the file "user/Backup/Backup.log" for the parameters which were successfully restored and for the parameters with which an error occurred, or after which parameter the error occurred.

Diagnostic Command Messages

Cause	Remedy
A parameter file is faulty	Check parameter files. Error occurs with manually created or modified parameter files, or in the case of incorrect transmission of parameter file to MMC
A required parameter file is not available or was incorrectly named	Check whether all files generated by command C6500 are available
File with comparative data is faulty or not available	Generate backup data again: Execute command C6500
An error occurred when a file in directory "user/Update" had been read	Check file in directory "user/Update"
MMC is defective	Check MMC and execute command C6600 again. If diagnostic message is displayed repeatedly: Replace MMC
MMC slot in control section is defective	Check MMC slot and, if necessary, replace control section or entire drive controller
MMC was not or not correctly formatted	Format MMC and generate backup data again: Execute command C6500. Directory "user" must have been created on MMC
MMC has not (or not completely) been plugged in MMC slot provided for this purpose	Plug MMC in controller and execute command C6600 again



Only Rexroth service engineers or especially trained users are allowed to replace the control section. The replacement of the entire drive controller is described in the Project Planning Manual for the power section.



Before replacing or formatting the MMC, save the stored data to avoid data loss.

See also Functional Description of firmware "MultiMediaCard (MMC)"

C6601 - Attributes Display: C6601
 Ident N°: C6601

10.2.299 C6602 Error when writing backup data (device)

Allocation	Contained in 02VRS:	«-»	«-»	«-»	
	Contained in 03VRS:	«-»	«-»	«-»	
	Contained in 04VRS:	«-»	«-»	«-»	
	Contained in 05VRS:	«-»	«-»	«-»	
	Contained in 06VRS:	«-»	«-»	«-»	«MPC»
	Contained in 07VRS:	«-»	«-»	«-»	«MPC»
	Contained in 08VRS:	«-»	«-»	«-»	«MPC»
	Supported by supply unit:	«-»			

During the execution of the command C6600, an error occurred when a parameter had been written to the active, non-volatile memory of the drive controller or a CCD slave.



The restored parameters are incomplete or faulty!

Diagnostic Command Messages



See the file "user/Backup/Backup.log" for the parameters which were successfully restored and for the parameters with which an error occurred, or after which parameter the error occurred.

Cause	Remedy
Incorrect access to parameter of a CCD slave	Check cross communication (CCD) and execute command C6600 again
Error when starting or stopping command C2200 or C2900	Check cross communication (CCD) and execute command C6600 again
An error occurred when a file from directory "user/Update" had been copied	Check available memory space on MMC

C6602 - Attributes **Display:** C6602
 Ident N°: C6602

10.2.300 C6603 Error when writing comparative data (backup memory)

Allocation	Contained in 02VRS:	«-»	«-»	«-»	
	Contained in 03VRS:	«-»	«-»	«-»	
	Contained in 04VRS:	«-»	«-»	«-»	
	Contained in 05VRS:	«-»	«-»	«-»	
	Contained in 06VRS:	«-»	«-»	«-»	«MPC»
	Contained in 07VRS:	«-»	«-»	«-»	«MPC»
	Contained in 08VRS:	«-»	«-»	«-»	«MPC»
	Supported by supply unit:	«-»			

During the execution of the command C6600, an error occurred when the comparative data had been written to the MultiMediaCard (MMC).



The restored parameters are basically complete! However, it was impossible to update the comparative data on the MMC; this causes parameters to be unnecessarily restored when the command is called again.



See the file "user/Backup/Backup.log" for the parameters which were restored.

Cause	Remedy
File with comparative data could not be written	Check available memory space on MMC and execute command C6600 again
MMC is defective	Check MMC and execute command C6600 again. If diagnostic message is displayed repeatedly: Replace MMC
MMC slot in control section is defective	Check MMC slot and, if necessary, replace control section or entire drive controller
MMC was not or not correctly formatted	Format MMC and generate backup data again: Execute command C6500. Directory "user" must have been created on MMC
MMC has not (or not completely) been plugged in MMC slot provided for this purpose	Plug MMC in controller and execute command C6600 again

Diagnostic Command Messages

 Only Rexroth service engineers or especially trained users are allowed to replace the control section. The replacement of the entire drive controller is described in the Project Planning Manual for the power section.

 Before replacing or formatting the MMC, save the stored data to avoid data loss.

See also Functional Description of firmware "MultiMediaCard (MMC)"

C6603 - Attributes Display: C6603
 Ident N°: C6603

10.2.301 C6604 Error when reading comparative data (device)

Allocation	Contained in 02VRS:	«-»	«-»	«-»	
	Contained in 03VRS:	«-»	«-»	«-»	
	Contained in 04VRS:	«-»	«-»	«-»	
	Contained in 05VRS:	«-»	«-»	«-»	
	Contained in 06VRS:	«-»	«-»	«-»	«MPC»
	Contained in 07VRS:	«-»	«-»	«-»	«MPC»
	Contained in 08VRS:	«-»	«-»	«-»	«MPC»
	Supported by supply unit:	«-»			

While command C6600 was executed, an error occurred in the drive controller or in a CCD slave when the comparative data was read.

 The restored parameters are basically complete! However, it was impossible to update the comparative data on the MMC; this causes parameters to be unnecessarily restored when the command is called again.

Cause	Remedy
Incorrect parameter access to a CCD slave	Check cross communication (CCD) and execute command C6600 again

C6604 - Attributes Display: C6604
 Ident N°: C6604

10.2.302 C6605 Warning, restoration incomplete (device)

Allocation	Contained in 02VRS:	«-»	«-»	«-»	
	Contained in 03VRS:	«-»	«-»	«-»	
	Contained in 04VRS:	«-»	«-»	«-»	
	Contained in 05VRS:	«-»	«-»	«-»	
	Contained in 06VRS:	«-»	«-»	«-»	«MPC»
	Contained in 07VRS:	«-»	«-»	«-»	«MPC»
	Contained in 08VRS:	«-»	«-»	«-»	«MPC»
	Supported by supply unit:	«-»			

During the execution of the command C6600, one or several parameters could not be restored in the active, non-volatile memory of the drive controller or a CCD slave.

Diagnostic Command Messages



The restored parameters are incomplete. No technical error occurred! Individual values of the parameters to be restored were not allowed, individual parameters were unknown in the firmware, or an integrated update of the firmware to be carried out was terminated with error.



See the file "user/Backup/Backup.log" for the parameters which were not restored.

Cause	Remedy
One or several parameters are unknown in firmware of drive controller or CCD slave	If update of firmware was carried out in special case update , command C6600 should be executed again. Otherwise: Check parameter files for parameters which are unknown or cannot be written.
One or several values in parameter files are not allowed (limit ranges, list size)	Check parameter files. Actually, error can only be caused by manually created or modified parameter files, or be due to incorrect transmission to MMC In exceptional cases, when firmware versions of backup firmware and restoring firmware are different, changes in parameter definitions can make individual parameter values become invalid.
Firmware update:	Check available memory space on local MMC of faulty drive

C6605 - Attributes **Display:** C6605
Ident N°: C6605

10.2.303 C7001 CCD: Impossible to adjust slave addresses

Allocation	Contained in 02VRS:	«-»	«-»	«-»	
	Contained in 03VRS:	«-»	«-»	«-»	
	Contained in 04VRS:	«-»	«-»	«-»	
	Contained in 05VRS:	«-»	«MPH»	«-»	
	Contained in 06VRS:	«-»	«-»	«-»	«MPC»
	Contained in 07VRS:	«-»	«-»	«-»	«MPC»
	Contained in 08VRS:	«-»	«-»	«-»	«MPC»
	Supported by supply unit:	«-»			

While command "S-0-1635, C7000 CCD: Command Adjust slave addresses " was executed, an error occurred.

Cause	Remedy
During execution of command C7000 and within the scope of remote address assignment, an attempt is made to write corresponding addresses of CCD slaves ("S-0-1040, Drive address of master communication") such as parameterized in "P-0-1636, CCD: Command topology". This is impossible, as CCD slaves are not in phase 2.	Put CCD slaves to phase 2: For example, switch CCD master to parameterization mode - or - As of MPx07: Execute command C7400

See also Functional Description of firmware "Cross Communication (CCD)"

C7001 - Attributes **Display:** C7001
Ident N°: C7001

10.2.304 C7101 CCD: Impossible to close ring

Allocation	Contained in 02VRS:	«-»	«-»	«-»	
	Contained in 03VRS:	«-»	«-»	«-»	
	Contained in 04VRS:	«-»	«-»	«-»	
	Contained in 05VRS:	«-»	«-»	«-»	
	Contained in 06VRS:	«-»	«-»	«-»	«MPC»
	Contained in 07VRS:	«-»	«-»	«-»	«MPC»
	Contained in 08VRS:	«-»	«-»	«-»	«MPC»
	Supported by supply unit:	«-»			

While command "P-0-1620.0.21, CCD: Command Close ring" (C7100) was executed, an error occurred.

Cause	Remedy
CCD group is not in SERCOS phase 4	Switch CCD group to SERCOS phase 4
Double ring is already existing (command execution was unnecessary)	-
There is not connection between last slaves of lines	Check connection between last slaves of lines (green link LED).
New ring delay could not be transferred to slave(s)	Restart command

For removing command errors see "Command Errors"

See also Functional Description of firmware "Cross Communication (CCD)"

C7101 - Attributes	Display:	C7101
	Ident N°:	C7101

10.2.305 C7201 CCD: Impossible to apply I/O configuration

Allocation	Contained in 02VRS:	«-»	«-»	«-»	
	Contained in 03VRS:	«-»	«-»	«-»	
	Contained in 04VRS:	«-»	«-»	«-»	
	Contained in 05VRS:	«-»	«-»	«-»	
	Contained in 06VRS:	«-»	«-»	«-»	«-»
	Contained in 07VRS:	«-»	«-»	«-»	«-»
	Contained in 08VRS:	«-»	«-»	«-»	«MPC»
	Supported by supply unit:	«-»			

While the command for applying the CCD I/O configuration (P-0-1620.0.31, C7200 CCD: Command Apply I/O configuration) was executed, an error occurred; the CCD I/O configuration cannot be applied.

Cause	Remedy
CCD group is not in SERCOS phase 2	Switch CCD group to SERCOS phase 2 using command "P-0-1620.0.5, C7400 CCD: Switching to phase 2"

See also Functional Description of firmware "Cross Communication (CCD)"

C7201 - Attributes	Display:	C7201
	Ident N°:	C7201

Diagnostic Command Messages

10.2.306 C7401 CCD: Impossible to switch to phase 2

Allocation	Contained in 02VRS:	«-»	«-»	«-»	
	Contained in 03VRS:	«-»	«-»	«-»	
	Contained in 04VRS:	«-»	«-»	«-»	
	Contained in 05VRS:	«-»	«-»	«-»	
	Contained in 06VRS:	«-»	«-»	«-»	«-»
	Contained in 07VRS:	«-»	«-»	«-»	«-»
	Contained in 08VRS:	«-»	«-»	«-»	«MPC»
	Supported by supply unit:	«-»			

While the command for switching to CCD phase 2 (P-0-1620.0.5, C7400 CCD: Switching to phase 2) was executed, an error occurred; switching to CCD phase 2 is not possible.

Cause	Remedy
Projected slaves were not detected in CCD phase 0	Observe note in P-0-1630 of CCD master. Check slave configuration or connected slaves.
Master does not receive its transmitted telegrams	Check SERCOS III wiring
Switching to CCD phase 1 was not possible	Observe note in P-0-1630 of CCD master
Switching to CCD phase 2 was not possible	Observe note in P-0-1630 of CCD master

See also Functional Description of firmware "Cross Communication (CCD)"

C7401 - Attributes
Display: C7401
Ident N°: C7401

10.2.307 C7501 CCD: Impossible to switch to phase 4

Allocation	Contained in 02VRS:	«-»	«-»	«-»	
	Contained in 03VRS:	«-»	«-»	«-»	
	Contained in 04VRS:	«-»	«-»	«-»	
	Contained in 05VRS:	«-»	«-»	«-»	
	Contained in 06VRS:	«-»	«-»	«-»	«-»
	Contained in 07VRS:	«-»	«-»	«-»	«-»
	Contained in 08VRS:	«-»	«-»	«-»	«MPC»
	Supported by supply unit:	«-»			

While the command for switching to CCD phase 4 (P-0-1620.0.6, C7500 CCD: Switching to phase 4) was executed, an error occurred; switching to CCD phase 4 is not possible.

Cause	Remedy
Error occurred in timing calculation of CCD master. Maybe, SERCOS timing cannot be set due to number of slaves or selected CCD modes.	Observe note in P-0-1630 of CCD master
An error occurred while telegram structure was checked. Maybe, it is not possible to transfer desired parameter cyclically or combine them in master-slave lists	Observe note in P-0-1630 of CCD master
Error in switching command "S-0-0127, C0100 Communication phase 3 transition check" of slaves	Observe note in S-0-0021 of faulty slave
Error in switching command "S-0-0128, C5200 Communication phase 4 transition check" of slaves	Observe note in S-0-0022 of faulty slave

See also Functional Description of firmware "Cross Communication (CCD)"

11 Extended Diagnosis (P-0-3219)

11.1 Displays C0254 to C0265

If an error code is not contained in the documentation, please contact our service department.

Display	E-code channel 1 (P3219 [0])	E-code channel 2 (P3219 [1])	Safety technology error
C0254	53		PROFIsafe is not allowed in conjunction with this firmware
	213		PROFIsafe configuration error: PROFIsafe was activated by P-0-3290 unequal zero. The precondition for this, however, is missing, as there is no PROFIBUS master communication available
C0255		596	Validation check with regard to parameterization "deceleration in the case of error reaction": Parameterization in parameters P-0-0119, P-0-0117 and P-0-3210 (bit 9) is not allowed
		600	No measuring system connected to connector X4
		33, 43	Encoder type is not supported by channel 2

Extended Diagnosis (P-0-3219)

Display	E-code channel 1 (P3219 [0])	E-code channel 2 (P3219 [1])	Safety technology error
C0256	216		Configuration error: "Safety related limited absolute position" or "safety related limited absolute end position" was configured, but the required homing encoder has not been connected to X4.x
	420		Configuration of a safety function that has not been released (safety related braking and holding system)
	421		Configuration of "safety related braking and holding system" (P-0-3300, bit0=1) with main spindle brake (P-0-0525, bit1=1) is not allowed
	422		Configuration of "safety related braking and holding system" (P-0-3300, bit0=1) and "best possible deceleration with torque disable" is not allowed
	423		Configuration of "safety related braking and holding system" (P-0-3300, bit0=1) and reaction "torque disable in the case of F7 errors" (P-0-3210, bit9=1) is not allowed
	424		Configuration of a safety function that has not been released (safety related I/Os)
	425		Configuration of a safety function that has not been released (safety related limited absolute end position)
	426		Configuration error: "Safety related braking and holding system" requires motor holding brake (P-0-0525, bit 2)
	428		Configuration of "safety related braking and holding system" (P-0-3300, bit0=1) and "best possible deceleration with return motion" is not allowed
	435		Configuration error: "Safety related braking and holding system" mustn't be operated with "self-releasing holding brake" (P-0-0525)!
	436		Configuration error: P-0-3307 mustn't be smaller than S-0-0207
	437		Configuration error: "NC or MLD error reaction" (P-0-0117) is not allowed together with "safety related braking and holding system"!
	438		Configuration error: "Safety related monitored deceleration" (P-0-3210, bit 13) mustn't be deselected!
	440		Configuration error: Signal "HAT-Steuer" (P-0-3301, bit 0) is missing or has been configured twice (P-0-0300)
	532		Configuration error: F7 error reaction not consistent P-0-3210=velocity command value reset and P-0-0119=torque-free.
	590		Configuration error: Contradictory direction of motion (involved parameters: P-0-3239, P-0-3240, P-0-3250, P-0-3260 or P-0-3270)
	591		Configuration error: "Gear independence with safety technology encoder mounted on the load side" is only allowed with rotary, load-related scaling for position, velocity and acceleration data (see P-0-3210, S-0-0044, S-0-0076, S-0-0160)
	592		Configuration error: "Gear independence with safety technology encoder mounted on the load side" and "safety related braking and holding system" are not allowed simultaneously (see P-0-3210, P-0-3300)
593		Configuration error: "Gear independence with safety technology encoder mounted on the load side" and "safety related limited absolute position" or "gear independence with safety technology encoder mounted on the load side" and "safety related limited absolute end position" are not allowed (see P-0-3210, P-0-3239, P-0-3240, P-0-3250)	
594		Configuration error: "Gear independence with safety technology encoder mounted on the load side" with motor encoder as safety technology encoder (X4) is not allowed	

Extended Diagnosis (P-0-3219)

Display	E-code channel 1 (P3219 [0])	E-code channel 2 (P3219 [1])	Safety technology error
C0257	48		No motor encoder or external encoder plugged at optional slot X4
C0265	214		Safety technology configuration error: "Safety related limited absolute position" and "motor-related scaling" have been configured

11.2 Displays C0723 to C2109

If an error code is not contained in the documentation, please contact our service department.

Display	E-code channel 1 (P3219 [0])	E-code channel 2 (P3219 [1])	Safety technology error
C0723	102		"C07_02 load defaults procedure for safety technology" presently cannot be executed, as channel 2 is still busy with execution of another safety technology command
C2103	1569		Safety related brake check: Determined load due to weight greater than 1.3 * "P-0-3303, Safety related holding system: Nominal load"
	1548, 1549, 1550		Safety related brake check: Test point holding torque of motor holding brake incorrectly carried out in positive direction
	1553, 1554, 1555		Safety related brake check: Test point holding torque of motor holding brake incorrectly carried out in negative direction
		510	Safety related brake check: Motor brake controlled
		507, 509	Safety related brake check: Redundant holding brake not released
C2104		630	Command execution of command C2100 is not allowed, because command C6200 is active
C2107	1569		Safety related brake check: Determined load due to weight greater than 1.3 * "P-0-3303, Safety related holding system: Nominal load"
	1558, 1559, 1560		Safety related brake check: Test point holding torque of redundant holding brake incorrectly carried out in positive direction
	1563, 1564, 1565		Safety related brake check: Test point holding torque of redundant holding brake incorrectly carried out in negative direction
		506	Safety related brake check: When the force due to weight is determined, motion is expected when the brakes have been released. The drive did not move. In spite of control, a brake does not release
		511	Safety related brake check: Redundant holding brake not released
		512	Safety related brake check: Motor brake controlled
	514	Safety related brake check: Motor brake not controlled	

Extended Diagnosis (P-0-3219)

Display	E-code channel 1 (P3219 [0])	E-code channel 2 (P3219 [1])	Safety technology error
C2108	1541		Safety related brake check: Channel 1 error-free, see error code channel 2
	1541		Safety related brake check: Channel 1 signals successful, see error message of channel 2
	1543		Brake check: Command C2100 is not allowed with selection "safety related operation"
	1543		Safety related brake check: Command C2100 is not allowed with selection "safety related operation"
	1545		Safety related brake check: Axis did not move [or less than half the monitoring window ("P-0-3310" / 2)]
	1546		Safety related brake check: Starting torque exceeded (P-0-0545 or P-0-0540 < P-0-0546)
	1546		Safety related brake check: Starting torque exceeded, P-0-0546 > P-0-0545 (or P-0-0540, when P-0-0545=0)
	1542, 1544		"Safety related brake check" error
	1545, 1547		Safety related brake check: - Axis did not move (<P-0-3310/2) or - Axis moved too far (>P-0-3310*2)
		507	Safety related brake check: Redundant holding brake not released
	508	Safety related brake check: Motor brake not controlled	
C2109	1551, 1556, 1561, 1566	582, 583	Safety related brake check: Incorrect torque normalization <ul style="list-style-type: none"> • Replacement of motor (P-0-3304 ↔ P-0-0051) • Incorrect current measurement (P-0-0043)

11.3 Displays C4001, C4002 and C6201

If an error code is not contained in the documentation, please contact our service department.

Extended Diagnosis (P-0-3219)

Display	E-code channel 1 (P3219 [0])	E-code channel 2 (P3219 [1])	Safety technology error
C4001	1086		Channel 2 signals error for internal command "homing procedure channel 2" Cause: P-0-3280 deviates by more than one internal measuring-system-dependent threshold from S-0-0051/S-0-0053 or no homing input channel 2 configured in P-0-3211
		153	Command "safety related homing procedure" was started. But no reference input at channel 2 was configured in parameter P-0-3211
		157	Command "safety related homing procedure" executed. Actual position value difference between channel 1 and channel 2 is greater than parameterized in P-0-3229
		163	Command "safety related homing procedure" was started. The actual position value systems of channel 1 and channel 2 were not synchronized before, this is automatically carried out in the transition command from 3 to 4
C4002	1087		Incorrect distance of dedicated points of channel 1 and 2 [S-0-0052/54 - S-0-0150/151 - P-0-3231] > P-0-3229*1.1
C6201	1492		Channel 2 signals command not executable
	1493	625, 629	Command not executable, because it has not been enabled (P-0-3300) or safety related braking and holding system has not been parameterized.
	1494	628	Command may only be started once after control voltage ON.
	1495	626	Command execution not allowed with active brake check (C2100).
	1496	627	Command execution only allowed with invalid brake status.

11.4 Displays Exxx, E3107 and E3115

If an error code is not contained in the documentation, please contact our service department.

Display	E-code channel 1 (P3219 [0])	E-code channel 2 (P3219 [1])	Safety technology error
Exxx	1xxx		In the case of warning on channel 1, 1000 is added to the error code
E3107	1311		Safety related reference is missing for monitoring in the case of "safety related limited absolute end position"
E3115	415, 417	254	Monitoring of time interval brake check Cause: Drive had been in "AF" for 15 minutes and brake check hasn't been carried out yet or the time defined in P-0-3302 was exceeded
E3115	1416, 1418		Safety related braking and holding system: "Prewarning, end of brake check time interval"

11.5 Displays F3112 to F3135

If an error code is not contained in the documentation, please contact our service department.

Extended Diagnosis (P-0-3219)

Display	E-code channel 1 (P3219 [0])	E-code channel 2 (P3219 [1])	Safety technology error
F3112	191		"Special mode safety related motion" selected with "safety related limited absolute position" without channel 2 having been homed
	312	179, 271	Safety related reference is missing for monitoring in the case of "safety related limited absolute end position"
		155	"Special mode safety related motion 1" selected with "safety related limited absolute position" without channel 2 having been homed
		156	"Special mode safety related motion 2" selected with "safety related limited absolute position" without channel 2 having been homed
		283, 284	Missing safety related reference for monitoring of "safety related limited absolute position" in "special mode safety related motion"
F3115	415, 417	254	Monitoring of time interval brake check: Cause: Drive had been in "AF" for 15 minutes and brake check hasn't been carried out yet or the time defined in P-0-3302 was exceeded
F3116	439	256	Monitoring of actual load torque: Nominal load torque of holding system exceeded
F3117	192		Validation error of actual position values channel 1 and 2 (in the case of safety related reference)
		154	Actual position value difference between channel 1 and channel 2 greater than determined internal measuring-system-dependent threshold
		158	With the configuration "reference input channel 2 with static signal", 24V were measured at the reference input outside of the tolerance window P-0-3231 +/- P-0-3229. Cause: Possibly short circuit to 24V.
F3122		219	Command "apply redundant holding brake" was started. Brake could not be applied within 50 ms (diagnostic input at channel 2 (X41) at 24V)
		221	The internal command "release redundant holding system" was started. Brake could not be released within 50 ms (diagnostic input at channel 2 (X41) at 0V)
		223	During the command "resurfacing of redundant holding brake", the redundant holding system is applied. The brake, however, could not be applied within 200 ms (diagnostic input at channel 2 (X41) at 24V)
		224	During the command "resurfacing of redundant holding brake", the redundant holding system is released. The brake, however, could not be released within 200 ms (diagnostic input at channel 2 (X41) at 0V)
		505	Safety related braking and holding system: Feedback signal from control module (HAT) is 0V Cause: Missing connection between control module (HAT) and diagnostic input at connector X41 (HSI11) or Error in control module (HAT)
		532	Safety related braking and holding system: Error in feedback signal of control module (HAT) Cause: Brake applied: Line interrupted, short circuit to 0V or error message of control module (HAT) or Brake released: Short circuit to 24V

Extended Diagnosis (P-0-3219)

Display	E-code channel 1 (P3219 [0])	E-code channel 2 (P3219 [1])	Safety technology error
F3123	432	518, 519, 556	Safety related braking and holding system: No valid brake check status during transition to special mode
		533, 534	Safety related braking and holding system: No valid brake check status during transition from parameter mode to operating mode with selection of special mode
F3130	23		Not all input signals of channel 1 are at low level during dynamization pulse
		26	During dynamization of input E1n of channel 2, the input does not go to 0V. Cause: Short circuit between input E1n and 24V.
		28	During dynamization of input E2n of channel 2, the input does not go to 0V. Cause: Short circuit between input E2n and 24V.
		29	During dynamization of input E3n of channel 2, the input does not go to 0V. Cause: Short circuit between input E3n and 24V.
		35	During dynamization of input E4n of channel 2, the input does not go to 0V. Cause: Short circuit between input E4n and 24V.

Extended Diagnosis (P-0-3219)

Display	E-code channel 1 (P3219 [0])	E-code channel 2 (P3219 [1])	Safety technology error
F3131	24	48	EA20 is statically at low level. Cause: Short circuit to GND or EA20 not connected or power supply at X41 missing
	26		EA20 is statically at high level. Cause: Short circuit to 24V
	151		Diagnostic/acknowledgment slave: EA20 does not toggle during initialization in operating mode (after phase progression or clear error). Cause: +24V are missing at X41 or short circuit to V+ or GND
	152	125, 141, 160	Diagnostic/acknowledgment slave: EA20 is statically at low level. Cause: Short circuit to 0V or EA20 not connected or power supply at X41 missing
	153		Diagnostic/acknowledgment slave: It was impossible to set EA20 to high level (it toggles)
	154		Diagnostic/acknowledgment slave: It was impossible to set EA20 to high level
	155	124, 150	Diagnostic/acknowledgment slave: EA20 is permanently at high level. Cause: Either by master or by short circuit to 24V
	161	46	Diagnostic/acknowledgment master: EA20 does not toggle during initialization in operating mode (after phase progression or clear error). Cause: One module in the group with non-activated safety technology or short circuit EA20 to 24 V
	163		Diagnostic/acknowledgment master: It was impossible to set EA20 to high level
	164		Diagnostic/acknowledgment master: EA20 longer than 600 ms at high level during acknowledgment request
	167		Diagnostic/acknowledgment master: EA20 does not toggle when safety door is locked
	170		Diagnostic/acknowledgment master: EA20 does not toggle when safety door is unlocked
	171	174	Single axis for diagnosis/acknowledgment: EA20 at low level for more than 10 ms (EA20 should be permanently at 24V). Cause: 24V supply missing at X41 or short circuit EA20 to 0V
		49	Diagnostic/acknowledgment master: EA20 does not toggle during initialization in operating mode (after phase progression or clear error). Cause: No voltage supply at X41 or short circuit EA20 to 0V
		124	Diagnostic/acknowledgment master: EA20 is permanently at high level. Cause: One module in the group with non-activated safety technology or short circuit EA20 to 24 V
		129	Diagnostic/acknowledgment slave: EA20 does not toggle. Cause: One module in the group with non-activated safety technology or short circuit EA20 to 24 V
	142	Safety door unlocked or diagnostic output at "safe" in the case of PLC control, although safety of zone does not exist	

Extended Diagnosis (P-0-3219)

Display	E-code channel 1 (P3219 [0])	E-code channel 2 (P3219 [1])	Safety technology error
F3132 ...	166		Diagnostic/acknowledgment master: A10 cannot be set to low level when safety door is locked
	169		Diagnostic/acknowledgment master: A10 cannot be set to high level when safety door is unlocked
	172		Single axis for diagnosis/acknowledgment: Channel 1 acknowledges safety and channel 2 does not. (A10 and A10n at high level)
	173		Single axis for diagnosis/acknowledgment: Channel 2 acknowledges safety and channel 1 does not. (A10 and A10n at low level)
	335		Safety related output has been activated/set; after a tolerance time of 2 seconds, feedback at check input E10 is missing (P-0-3212, bit 9 = high for t > 10ms)
	336		Safety related output has been deactivated/reset; after a tolerance time of 2 seconds, feedback at check input E10 is still present (P-0-3212, bit 9 = low for t > 10ms)
	33, 36, 38, 40, 42, 100, 101, 168		Diagnostic/acknowledgment master: E10 has low level at end of unlocking of safety door
	93, 165		Diagnostic/acknowledgment master: E10 has high level at end of locking of safety door
		126	Diagnostic master/slave with PLC control: During transition to normal operation, EA10n cannot be set to 24V (Short circuit EA10n to 0V)
		127	In safety related status and control of a safety door: EA10n at high level. Remedy: Check wiring in control circuit
		128	In safety related status, EA10n (with configuration of a PLC control) cannot be set to low level. Cause: EA10n has short circuit to 24V or error in wiring
		143	Error in control of safety door. Cause: EA10n defective or feedback via E10 missing
		201	Activation safety related output: Control of channel 2 has not taken place within one second Cause: Internal relay defective or output EA10n is at 24V
		206	Activation safety related output: The drive is not able to switch to the active status within 1s. Remedy: Check wiring in control circuit and feedback circuit (input E10 = 0V)
	209	Activation safety related output: Control of channel 1 via A10 has not taken place within one second	
	146, 176	In non-safety-related status, EA10n cannot be set to high level	

Extended Diagnosis (P-0-3219)

Display	E-code channel 1 (P3219 [0])	E-code channel 2 (P3219 [1])	Safety technology error
... F3132		147, 175	In safety related status, EA10n cannot be set to low level
		202, 204	Activation safety related output: After activated status has been reached, this status is permanently checked. An error was detected during this check. Remedy: Check wiring in control circuit and feedback circuit (input E10 = 0V)
		207, 208	Deactivation safety related output: After safety related status has been reached at load circuit, this status is permanently checked. An error was detected during this check. Remedy: Check wiring in control circuit and feedback circuit (input E10 = 24V)
		211, 212	Deactivation safety related output: Upon request, drive is not able to switch load circuit to safety related status within two seconds. Cause: Incorrect control of channel 2 or feedback via channel 1 not ok (input E10 = 24V)
F3134	109		Interval "dynamization of safety function selection" (EA30 EDynK1) is greater P-0-3223 * 1.2
	111, 117	63	Interval of dynamization signal (EA30 or P-0-3212, bit 10) exceeded (P-0-3223)
		139	In synchronization phase of dynamization during transition to operating mode, dynamization signal is longer than 1.5-fold time of P-0-3223 at 24V
F3135	108		Pulse width of dynamization signal (EA30 or P-0-3212, bit 10) shorter than minimum pulse width of 30ms
	98, 99, 116	57	Pulse width of dynamization signal (EA30 or P-0-3212, bit 10) greater than P-0-3224
		64	Dynamization pulse at EA30 smaller than minimum pulse width (30ms)
		140	In synchronization phase of dynamization during transition to operating mode, dynamization signal is longer than 1.5-fold time of P-0-3224 at 0V

11.6 Display F3140

If an error code is not contained in the documentation, please contact our service department.

Display	E-code channel 1 (P3219 [0])	E-code channel 2 (P3219 [1])	Safety technology error
F3140 ...	54	426	P-0-3291 of channels 1 and 2 are different
	55	425	P-0-3290 of channels 1 and 2 are different
	56	404	P-0-3210 of channels 1 and 2 are different
	57		P-0-3211 of channels 1 and 2 are different
	58		P-0-3240, P-0-3250, P-0-3260 and P-0-3270 of channels 1 and 2 are different
	77	439	P-0-3239 of channels 1 and 2 are different
	78	440	P-0-3295 of channels 1 and 2 are different

Extended Diagnosis (P-0-3219)

Display	E-code channel 1 (P3219 [0])	E-code channel 2 (P3219 [1])	Safety technology error
	79	441	P-0-3300 of channels 1 and 2 are different
	120	363, 364, 365	Safety technology parameters of channels 1 and 2 are different Channel 1: Up to FWA-INDRV_-MPx03V08 P-0-3220, then P-0-3234 Channel 2: P-0-3220
	121	369, 370, 371	Safety technology parameters of channels 1 and 2 are different Channel 1: Up to FWA-INDRV_-MPx03V08 P-0-3221, then P-0-3220 Channel 2: P-0-3221
	122	366, 367, 368	Safety technology parameters of channels 1 and 2 are different Channel 1: Up to FWA-INDRV_-MPx03V08 P-0-3222, then P-0-3221 Channel 2: P-0-3222
	123	387, 388, 389	Safety technology parameters of channels 1 and 2 are different Channel 1: Up to FWA-INDRV_-MPx03V08 P-0-3223, then P-0-3222 Channel 2: P-0-3223
	124	390, 391, 392	Safety technology parameters of channels 1 and 2 are different Channel 1: Up to FWA-INDRV_-MPx03V08 P-0-3224, then P-0-3223 Channel 2: P-0-3224
... F3140	125	418, 419, 420	Safety technology parameters of channels 1 and 2 are different Channel 1: Up to FWA-INDRV_-MPx03V08 P-0-3225, then P-0-3224 Channel 2: P-0-3225
...	126	422, 423, 424	Safety technology parameters of channels 1 and 2 are different Channel 1: Up to FWA-INDRV_-MPx03V08 P-0-3229, then P-0-3225 Channel 2: P-0-3229
	127	360, 361, 362	Safety technology parameters of channels 1 and 2 are different Channel 1: Up to FWA-INDRV_-MPx03V08 P-0-3230, then P-0-3229 Channel 2: P-0-3230
	128	372, 373, 374	Safety technology parameters of channels 1 and 2 are different Channel 1: Up to FWA-INDRV_-MPx03V08 P-0-3231, then P-0-3230 Channel 2: P-0-3231
	129	393, 394, 395	Safety technology parameters of channels 1 and 2 are different Channel 1: Up to FWA-INDRV_-MPx03V08 P-0-3232, then P-0-3231 Channel 2: P-0-3232
	130	410, 411, 412	Safety technology parameters of channels 1 and 2 are different Channel 1: Up to FWA-INDRV_-MPx03V08 P-0-3233, then P-0-3232 Channel 2: P-0-3233
	131	414, 415, 416	Safety technology parameters of channels 1 and 2 are different Channel 1: Up to FWA-INDRV_-MPx03V08 P-0-3234, then P-0-3233 Channel 2: P-0-3234

Extended Diagnosis (P-0-3219)

Display	E-code channel 1 (P3219 [0])	E-code channel 2 (P3219 [1])	Safety technology error
	132	348, 349, 350	P-0-3241 of channels 1 and 2 are different
	133	351, 352, 353	P-0-3242 of channels 1 and 2 are different
	134	336, 337, 338	P-0-3243 of channels 1 and 2 are different
	135	324, 325, 326	P-0-3244 of channels 1 and 2 are different
	136		P-0-3245 of channels 1 and 2 are different
	137	354, 355, 356	P-0-3251 of channels 1 and 2 are different
	138	357, 358, 359	P-0-3252 of channels 1 and 2 are different
	139	339, 340, 341	P-0-3253 of channels 1 and 2 are different
	140	327, 328, 329	P-0-3254 of channels 1 and 2 are different
	141		P-0-3255 of channels 1 and 2 are different
...	142	342, 343, 344	P-0-3263 of channels 1 and 2 are different
F3140	143	330, 331, 332	P-0-3264 of channels 1 and 2 are different
...	144		P-0-3265 of channels 1 and 2 are different
	145	345, 346, 347	P-0-3273 of channels 1 and 2 are different
	146	333, 334, 335	P-0-3274 of channels 1 and 2 are different
	147		P-0-3275 of channels 1 and 2 are different
	350	442, 443, 444	P-0-3302 of channels 1 and 2 are different
	351	450, 451, 452	P-0-3306 of channels 1 and 2 are different
	352	454, 455, 456	P-0-3307 of channels 1 and 2 are different
	353	462, 463, 464	P-0-3311 of channels 1 and 2 are different
	354	466, 467, 468	P-0-3226 of channels 1 and 2 are different
	355	470, 471, 472	P-0-3246 of channels 1 and 2 are different

Display	E-code channel 1 (P3219 [0])	E-code channel 2 (P3219 [1])	Safety technology error
... F3140	356	474, 475, 476	P-0-3256 of channels 1 and 2 are different
	357	478, 479, 480	P-0-3266 of channels 1 and 2 are different
	358	482, 483, 484	P-0-3276 of channels 1 and 2 are different
	368	432, 433, 434	P-0-3235 of channels 1 and 2 are different
	369	436, 437, 438	P-0-3236 of channels 1 and 2 are different
	370	446, 447, 448	P-0-3303 of channels 1 and 2 are different
	371	458, 459, 460	P-0-3310 of channels 1 and 2 are different
	372	486, 487, 488	P-0-3304 of channels 1 and 2 are different
		405	P-0-3240 of channels 1 and 2 are different
		406	P-0-3250 of channels 1 and 2 are different
		407	P-0-3260 of channels 1 and 2 are different
		408	P-0-3270 of channels 1 and 2 are different
		396, 400	P-0-3211 (input E1n) of channels 1 and 2 are different
		397, 401	P-0-3211 (input E2n) of channels 1 and 2 are different
		398, 402	P-0-3211 (input E3n) of channels 1 and 2 are different
		399, 403	P-0-3211 (input E4n) of channels 1 and 2 are different
	148	428, 429, 430	P-0-3282 of channels 1 and 2 are different

11.7 Displays F3141 and F3142

If an error code is not contained in the documentation, please contact our service department.

Extended Diagnosis (P-0-3219)

Display	E-code channel 1 (P3219 [0])	E-code channel 2 (P3219 [1])	Safety technology error
F3141	3	58	Selection validation error: Signal "BA" of channels 1 and 2 is unequal
	200	59	Selection validation error: Signal "ASP" of channels 1 and 2 is unequal
	201	60	Selection validation error: Signal "ZT" of channels 1 and 2 is unequal
	202	61	Selection validation error: Signal "S1" of channels 1 and 2 is unequal
	203	62	Selection validation error: Signal "S2" of channels 1 and 2 is unequal
	330	195	Selection validation error: Signal "safety related input 1" of channels 1 and 2 is unequal
	331	196	Selection validation error: Signal "safety related input 2" of channels 1 and 2 is unequal
	332	197	Selection validation error: Signal "safety related input 3" of channels 1 and 2 is unequal
	333	198	Selection validation error: Signal "safety related input 4" of channels 1 and 2 is unequal
	334	199	Selection validation error: Signal "safety related output" of channels 1 and 2 is unequal
F3142	35		Activation time of enabling control (P-0-3222) exceeded in special mode safety related motion
	37		Up to MPx04: Activation time of enabling control (P-0-3222) exceeded in special mode safety related motion SBB2 As of MPx05: Activation time of enabling control exceeded (P-0-3246/P-0-3256/P-0-3266/P-0-3276)
		68	Activation time of enabling control (P-0-3222) exceeded
		578	Individual activation time of enabling control (P-0-3246) exceeded when selecting special mode safety related motion SBB1
		579	Individual activation time of enabling control (P-0-3256) exceeded when selecting special mode safety related motion SBB2
		580	Individual activation time of enabling control (P-0-3266) exceeded when selecting special mode safety related motion SBB3
		581	Individual activation time of enabling control (P-0-3276) exceeded when selecting special mode safety related motion SBB4

11.8 Displays F3144 to F3152

If an error code is not contained in the documentation, please contact our service department.

Extended Diagnosis (P-0-3219)

Display	E-code channel 1 (P3219 [0])	E-code channel 2 (P3219 [1])	Safety technology error
F3144	53	599	PROFIsafe is not allowed in conjunction with this firmware
...	76	173	"Deactivation of acknowledgment support: single acknowledgment" and "master for diagnosis and acknowledgment" (in P-0-3210) configured, this is not allowed

Extended Diagnosis (P-0-3219)

Display	E-code channel 1 (P3219 [0])	E-code channel 2 (P3219 [1])	Safety technology error
	499	585	Configuration error: Switch drive to P2, clear error and switch to P4 again; C0256 is then signaled with corresponding error code in P-0-3219
		5	As of MPx04: Mode selector was configured twice in P-0-3211
		6	As of MPx04: Drive interlock was configured twice in P-0-3211
		7	As of MPx04: Enabling control was configured twice in P-0-3211
		8	As of MPx04: Reference input was configured twice in P-0-3211
		9	As of MPx04: Safety switch 1 was configured twice in P-0-3211
		10	As of MPx04: Safety switch 2 was configured twice in P-0-3211
		12	As of MPx04: No valid configuration in P-0-3211
		95	PROFIsafe and hardware inputs configured (in P-0-3211), this is not allowed
		184	Mode selector was parameterized in P-0-3211, this is not allowed when using PROFIsafe
		185	Drive interlock was parameterized in P-0-3211, this is not allowed when using PROFIsafe
		186	Enabling control was parameterized in P-0-3211, this is not allowed when using PROFIsafe
		187	Reference input was configured twice in P-0-3211
...		188	"Safety switch 1" was parameterized in P-0-3211, this is not allowed when using PROFIsafe
F3144		189	"Safety switch 2" was parameterized in P-0-3211, this is not allowed when using PROFIsafe
...		190	"Safety related input 1" was configured twice in P-0-3211
		191	"Safety related input 2" was configured twice in P-0-3211
		192	"Safety related input 3" was configured twice in P-0-3211
		193	"Safety related input 4" was configured twice in P-0-3211
		215	Diagnostic input of redundant holding brake was configured twice in P-0-3211
		216	Safety related braking and holding system parameterized, but no diagnostic input was configured for channel 2 in P-0-3211
		490	Configuration error: "Safety related limited absolute position" and "gear independence with safety technology encoder mounted on the load side" not allowed
		491	Configuration error: "Safety related limited absolute end position" and "gear independence with safety technology encoder mounted on the load side" not allowed
		492	Configuration error: "Safety related braking and holding system" and "gear independence with safety technology encoder mounted on the load side" not allowed
		609	Configuration error: Both directions (P-0-3300 bit 9/10) were parameterized as direction input for the brake check
		180, 181, 182, 183	Safety related input 1-4 was parameterized for safety technology 24V EA, this is only possible in conjunction with PROFIsafe

Extended Diagnosis (P-0-3219)

Display	E-code channel 1 (P3219 [0])	E-code channel 2 (P3219 [1])	Safety technology error
... F3144		568, 572	Monitoring for direction of rotation was parameterized differently in P-0-3239 and P-0-3240
		569, 573	Monitoring for direction of rotation was parameterized differently in P-0-3239 and P-0-3250
		570, 574	Monitoring for direction of rotation was parameterized differently in P-0-3239 and P-0-3260
		571, 575	Monitoring for direction of rotation was parameterized differently in P-0-3239 and P-0-3270
F3145		67	Diagnostic master with control of safety door. During transition to normal operation the door cannot be locked. Cause: Error in wiring of safety door or short circuit between EA10n, A10, E10 and 24V
F3146		47	Difference in measuring system between incremental and analog system is greater than 1/4 division period
		66	During measuring system evaluation, two active counting edges were detected. The information no longer is unequivocal (position error)
		120, 121	Incorrect encoder signals. Amplitude monitoring
		33, 43, 604, 605	Encoder type is not supported by channel 2
F3147	299		Danger to persons! The firmware used is a test version and the specific safety technology firmware test was not carried out for this firmware. It is only destined for a limited time and restricted applications. Contact our service department.
F3152	47	172, 200	Safety parameters cannot be stored in the safety memory (wrong version) (Invalid parameter set, probably of a previous version)

11.9 Displays F7010 to F7022

If an error code is not contained in the documentation, please contact our service department.

Display	E-code channel 1 (P3219 [0])	E-code channel 2 (P3219 [1])	Safety technology error
F7010	9	69	P-0-3243 exceeded in "special mode safety related motion 1"
	14	90	P-0-3253 exceeded in "special mode safety related motion 2"
	19	93	P-0-3263 exceeded in "special mode safety related motion 3"
	22	94	P-0-3273 exceeded in "special mode safety related motion 4"
F7011	10	88	P-0-3241 exceeded in "special mode safety related motion 1"
	15	91	P-0-3251 exceeded in "special mode safety related motion 2"

Extended Diagnosis (P-0-3219)

Display	E-code channel 1 (P3219 [0])	E-code channel 2 (P3219 [1])	Safety technology error
F7012	11	89	P-0-3242 exceeded in "special mode safety related motion 1"
	16	92	P-0-3252 exceeded in "special mode safety related motion 2"
F7013	7	1	P-0-3244 exceeded in "special mode safety related motion 1"
	12	11	P-0-3254 exceeded in "special mode safety related motion 2"
	17	18	P-0-3264 exceeded in "special mode safety related motion 3"
	20	22	P-0-3274 exceeded in "special mode safety related motion 4"
F7020	94	133	P-0-3234 was exceeded
F7021	313	177	P-0-3235 was exceeded
	314	178	P-0-3236 was exceeded
	315, 327		Safety related end position was exceeded: Tracked threshold was exceeded by more than P-0-3232 Position polarity, inverted → safety related end position, positive Otherwise → safety related end position, negative
	316, 328		Safety related end position was exceeded: Tracked threshold was exceeded by more than P-0-3232 Position polarity, inverted → safety related end position, negative Otherwise → safety related end position, positive
	319, 321		Safety related end position was exceeded: Command values point to forbidden direction Position polarity, inverted → safety related end position, positive Otherwise → safety related end position, negative
	320, 322		Safety related end position was exceeded: Command values point to forbidden direction Position polarity, inverted → safety related end position, negative Otherwise → safety related end position, positive
F7022	431		Missing feedback or brake controlled with drive enable missing

11.10 Displays F7030 to F7031

If an error code is not contained in the documentation, please contact our service department.

Extended Diagnosis (P-0-3219)

Display	E-code channel 1 (P3219 [0])	E-code channel 2 (P3219 [1])	Safety technology error
F7030	194		P-0-0048 > P-0-3233 in safety related operational stop
	197		Operating mode position control: Derived position command value > P-0-3233 in safety related operational stop
	4, 196	97, 98, 265, 266	P-0-3230 exceeded in safety technology function "safety related operational stop"
F7031	5	576	P-0-3232 exceeded in negative direction in "special mode safety related motion"
	6	577	P-0-3232 exceeded in positive direction in "special mode safety related motion"
	588		Positive monitoring of direction of motion has detected motion in negative direction (> P-0-3232)
	589		Negative monitoring of direction of motion has detected motion in positive direction (> P-0-3232)
		101	P-0-3232 exceeded in positive direction in "special mode safety related motion 4"
		102	P-0-3232 exceeded in negative direction in "special mode safety related motion 4"
		103	P-0-3232 exceeded in positive direction in "special mode safety related motion 3"
		104	P-0-3232 exceeded in negative direction in "special mode safety related motion 3"
		105	P-0-3232 exceeded in positive direction in "special mode safety related motion 2"
		106	P-0-3232 exceeded in negative direction in "special mode safety related motion 2"
		107	P-0-3232 exceeded in positive direction in "special mode safety related motion 1"
	108	P-0-3232 exceeded in negative direction in "special mode safety related motion 1"	

11.11 Displays F7040 to F7043

If an error code is not contained in the documentation, please contact our service department.

Extended Diagnosis (P-0-3219)

Display	E-code channel 1 (P3219 [0])	E-code channel 2 (P3219 [1])	Safety technology error
F7040	450	445	Validation error parameterized - effective threshold P-0-3302
	451	453	Validation error parameterized - effective threshold P-0-3306
	452	457	Validation error parameterized - effective threshold P-0-3307
	453	465	Validation error parameterized - effective threshold P-0-3311
	454	469	Validation error parameterized - effective threshold P-0-3226
	455	473	Validation error parameterized - effective threshold P-0-3246
	456	477	Validation error parameterized - effective threshold P-0-3256
	457	481	Validation error parameterized - effective threshold P-0-3266
	458	485	Validation error parameterized - effective threshold P-0-3276
	468	431	Validation error parameterized - effective threshold P-0-3235
	469	435	Validation error parameterized - effective threshold P-0-3236
	470	449	Validation error parameterized - effective threshold P-0-3303
	471	461	Validation error parameterized - effective threshold P-0-3310
	472	489	Validation error parameterized - effective threshold P-0-3304
		324, 326	325, 326
	327, 329	328, 329	P-0-3254 of channels 1 and 2 are different
	410, 412	411, 412	P-0-3233 of channels 1 and 2 are different
F7043		295	Output stage cannot be switched on via channel 2 during transition from drive interlock or safety related standstill to a special mode
		267, 500	Output stage cannot be switched on via channel 2 during transition to normal operation
		643	The output stage cannot be switched on via channel 2 in normal operation
		644, 646, 648	645, 647, 648

11.12 Displays F7050 to F7051

If an error code is not contained in the documentation, please contact our service department.

Extended Diagnosis (P-0-3219)

Display	E-code channel 1 (P3219 [0])	E-code channel 2 (P3219 [1])	Safety technology error
F7050	27		Time for safety related stopping process exceeded during transition to safety related standstill Cause: Actual velocity value > P-0-3233 or drive enable still set
	28		Time for safety related stopping process exceeded during transition to drive interlock Cause: Actual velocity value > P-0-3233 or drive enable still set
	32		Time for safety related stopping process exceeded during transition to safety related operational stop (Actual velocity value > P-0-3233)
	90		Time for safety related stopping process exceeded (P-0-3220 or P-0-3225) during transition to parameter mode
	91		Time for safety related stopping process exceeded during transition to internal error status "safety related standstill error" (the error reaction could not remove drive enable within the time P-0-3220/P-0-3225)
		601	Configuration error: P-0-0117="1" (NC error reaction activated; with F3 error) and transition time (P-0-3220/P-0-3225) parameterized smaller than 30s
		123, 290	Time for safety related stopping process exceeded (P-0-3220) during transition to safety related standstill or drive interlock Cause: Actual velocity value > P-0-3233 or drive enable still set
		134, 288	Time for safety related stopping process exceeded (P-0-3225) during transition to safety related standstill or drive interlock Cause: Actual velocity value > P-0-3233 or drive enable still set
		144, 285, 557	Time for safety related stopping process exceeded (P-0-3220) during transition to safety related operational stop Cause: Actual velocity value > P-0-3233
	145, 286	Time for safety related stopping process exceeded (P-0-3225) during transition to safety related operational stop Cause: Actual velocity value > P-0-3233	

Extended Diagnosis (P-0-3219)

Display	E-code channel 1 (P3219 [0])	E-code channel 2 (P3219 [1])	Safety technology error
F7051	411		Safety related braking and holding system: When decelerating with "velocity command value reset with ramp and filter", the deceleration ramp has fallen below the value set in P-0-3282
	205, 208, 217		In the safety technology function "safety related standstill", the deceleration ramp has fallen below the value set for safety related monitored deceleration (P-0-3282)
	206, 209, 218		In the safety technology function "safety related operational stop", the deceleration ramp has fallen below the value set for safety related monitored deceleration (P-0-3282)
	207, 210, 219		In the safety technology function "safety related drive interlock", the deceleration ramp has fallen below the value set for safety related monitored deceleration (P-0-3282)
	270, 271, 272		During the transition to "safety related standstill error", the deceleration ramp has fallen below the value set for safety related monitored deceleration (P-0-3282)
		502	During best possible deceleration, drive is not able to come to standstill within P-0-3282
		547	Drive is not able to come to standstill within the parameterized monitoring limits
		559	Drive is not able to come to the special mode motion within the parameterized monitoring limits (P-0-3225 or P-0-3220, P-0-3282)
		563	During NC-controlled transition to the special mode standstill [after delay was over (P-0-3226)], drive is not able to come to standstill within the parameterized monitoring limits (P-0-3225 or P-0-3220, P-0-3282)
		161, 272, 273	In the function "safety related monitored deceleration during transition from normal operation to safety related standstill/operational stop", drive is not able, within the scope of possible acceleration, to reach standstill within transition time P-0-3220
		162, 274	In the function "safety related monitored deceleration during transition from safety related operation to safety related standstill/operational stop", drive is not able, within the scope of possible acceleration, to reach standstill within transition time P-0-3225
	565, 589	During drive-controlled stopping process, drive is not able to come to standstill within P-0-3282	

11.13 Displays F8027 to F8135

If an error code is not contained in the documentation, please contact our service department.

Display	E-code channel 1 (P3219 [0])	E-code channel 2 (P3219 [1])	Safety technology error
F8027	113		Drive enable is set in internal error status "safety related standstill error"
	114		Drive enable is set in safety technology function "safety related standstill"
	115		Drive enable is set in safety technology function "drive interlock"
	303		Drive enable is set with "parking axis"

Extended Diagnosis (P-0-3219)

Display	E-code channel 1 (P3219 [0])	E-code channel 2 (P3219 [1])	Safety technology error
F8133		637, 642	Drive enable was set in safety related standstill
		638, 641	Drive enable was set in drive interlock
		639	Drive enable was set with parking axis
F8134	273		During the transition to "safety related standstill error", deceleration ramp has fallen below the value set in P-0-3282
	405		Safety related braking and holding system: Missing feedback or brake controlled with drive enable missing
	406		Safety related braking and holding system: Missing control of redundant holding brake without drive enable in standstill
	408		Safety related braking and holding system: Missing control of motor holding brake ("P-0-3307, Safety technology - drive off delay time" is running)
		235, 542	Motor brake or redundant holding brake released, although output stage is not active Remedy: Check control of brakes
F8135	205		In the safety technology function "safety related standstill", the deceleration ramp has fallen below the value set for safety related monitored deceleration (P-0-3282)
	207		In the safety technology function "safety related drive interlock", the deceleration ramp has fallen below the value set for safety related monitored deceleration (P-0-3282)
	272	566, 567, 586	During the transition to "safety related standstill error", deceleration ramp has fallen below the value set in P-0-3282
	273		F7 error reaction: During the transition to "safety related standstill error", deceleration ramp has fallen below the value set in P-0-3282
	407		Safety related braking and holding system: Missing control of redundant holding brake without drive enable Cause: Delay by motor holding brake is not sufficient
	410		Time for safety related stopping process exceeded, the error reaction could not remove drive enable within the time P-0-3220/P-0-3225 Remedy: Check parameterization P-0-3220/P-0-3225 and S-0-0207
	412, 413	546	Safety related braking and holding system: When decelerating with "velocity command value reset", the deceleration ramp has fallen below the value set in P-0-3282
		592	After an F7 error has occurred, the drive accelerates in spite of velocity command value reset Cause: Possibly commutation error
		619, 620	In the case of error, the drive is not able, during drive-controlled stopping process, to come to standstill within the parameterized monitoring limits. Error is generated before P-0-3226 is over.

11.14 Display F8201

If an error code is not contained in the documentation, please contact our service department.

Extended Diagnosis (P-0-3219)

Display	E-code channel 1 (P3219 [0])	E-code channel 2 (P3219 [1])	Safety technology error
F8201		5	Up to MPx03: Mode selector was configured twice in P-0-3211
		6	Up to MPx03: Drive interlock was configured twice in P-0-3211
		7	Up to MPx03: Enabling control was configured twice in P-0-3211
		8	Up to MPx03: Reference input was configured twice in P-0-3211
		9	Up to MPx03: Safety switch 1 was configured twice in P-0-3211
		10	Up to MPx03: Safety switch 2 was configured twice in P-0-3211
		12	Up to MPx03: No valid configuration in P-0-3211
		159	Version of safety memory does not match firmware Remedy: Load defaults procedure command and then reload and store safety technology parameters

Extended Diagnosis (P-0-3219) as of MPx07

12 Extended Diagnosis (P-0-3219) as of MPx07

12.1 Displays C0254 to C0265

If an error code is not contained in the documentation, please contact our service department.

Display	E-code channel 1 (P3219 [0])	E-code channel 2 (P3219 [1])	Safety technology error
C0254	213		PROFIsafe configuration error: PROFIsafe was activated by P-0-3290 unequal to zero. The precondition for this, however, is missing, as there is no PROFIBUS master communication available
C0255		596	Validation check with regard to parameterization "deceleration in the case of error reaction": Parameterization in parameters P-0-0119, P-0-0117 and P-0-3210 (bit 9) is not allowed
		600	No measuring system connected to X4
		33, 43	Encoder type is not supported by channel 2

Extended Diagnosis (P-0-3219) as of MPx07

Display	E-code channel 1 (P3219 [0])	E-code channel 2 (P3219 [1])	Safety technology error
C0256 ...	216		Configuration error: "Safely-monitored position" or "Safely-limited position" was configured, but the required homing encoder has not been connected to X4.x
	420		Configuration of a safety function that has not been released (safe braking and holding system)
	421		Configuration of "safe braking and holding system" (P-0-3300, bit0=1) with main spindle brake (P-0-0525, bit1=1) is not allowed
	422		Configuration of "safe braking and holding system" (P-0-3300, bit0=1) and "best possible deceleration with torque disable" is not allowed
	423		Configuration of "safe braking and holding system" (P-0-3300, bit0=1) and reaction "torque disable in the case of F7 errors" (P-0-3210, bit9=1) is not allowed
	424		Configuration of a safety function that has not been released (safe I/Os)
	425		Configuration of a safety function that has not been released (Safely-limited position)
	426		Configuration error: "Safe braking and holding system" requires motor holding brake (P-0-0525, bit 2)
	428		Configuration of "safe braking and holding system" (P-0-3300, bit0=1) and "best possible deceleration with return motion" is not allowed
	435		Configuration error: "Safe braking and holding system" may not be operated with "self-releasing holding brake" (P-0-0525)
	436		Configuration error: P-0-3307 may not be smaller than S-0-0207
	437		Configuration error: "NC or MLD error reaction" (P-0-0117) is not allowed together with "safe braking and holding system"
	438		Configuration error: "Safely-monitored deceleration" (P-0-3210, bit 13) may not be deselected
	440		Configuration error: Signal "HAT-Steuer" (P-0-3301, bit 0) is missing or has been configured twice (P-0-0300)
	532		Configuration error: F7 error reaction not consistent P-0-3210 = velocity command value reset and P-0-0119 = torque-free.
	590		Configuration error: Contradictory direction of motion (involved parameters: P-0-3239, P-0-3240, P-0-3250, P-0-3260 or P-0-3270)
	591		Configuration error: "Gear independence with safety technology encoder mounted on the load side" is only allowed with rotary, load-related scaling for position, velocity and acceleration data (see P-0-3210, S-0-0044, S-0-0076, S-0-0160)
592		Configuration error: "Gear independence with safety technology encoder mounted on the load side" and "safe braking and holding system" are not allowed simultaneously (see P-0-3210, P-0-3300)	
593		Configuration error: "Gear independence with safety technology encoder mounted on the load side" and "Safely-monitored position" or "gear independence with safety technology encoder mounted on the load side" and "Safely-limited position" are not allowed (see P-0-3210, P-0-3239, P-0-3240, P-0-3250)	

Extended Diagnosis (P-0-3219) as of MPx07

Display	E-code channel 1 (P3219 [0])	E-code channel 2 (P3219 [1])	Safety technology error
... C0256	734		Configuration error: Parameter set switching of group "load gear" is not allowed if "Redundant holding brake available" (bit 0="1") is configured in P-0-3300 and "Load reference" is set in S-0-0086
	911		Configuration error: P-0-3317 may not be smaller than P-0-3316
	999		Configuration error: P-0-3305 may not be smaller than S-0-0206
C0257	48		No measuring system connected to X4
	721, 722		Inadmissible encoder type at X4
	594		Configuration error: "Gear independence with load-side safety technology encoder" (P-0-3210, bit15="1") with motor encoder as safety technology encoder (X4) is not allowed
		535	Configuration error: Absolute encoder monitoring is deactivated for slot X4. This is not allowed. Check S-0-0277, S-0-0115 and P-0-0328, bit 15.
C0265	214		Configuration error: "Safely-monitored position" and "motor-related scaling" have been configured

12.2 Displays C0723 to C2109

If an error code is not contained in the documentation, please contact our service department.

Display	E-code channel 1 (P3219 [0])	E-code channel 2 (P3219 [1])	Safety technology error
C0723	102		Presently, "C0702" cannot be executed, as channel 2 is still busy with execution of another safety technology command
C2103	1569		Safe brake check: Determined load due to weight greater than $1.3 * P-0-3303$
	1549, 1550		Safe brake check: Test point holding torque of motor holding brake incorrectly carried out in positive direction
	1554, 1555		Safe brake check: Test point holding torque of motor holding brake incorrectly carried out in negative direction
		510	Safe brake check: Motor brake controlled
		507, 509	Safe brake check: Redundant holding brake not released
	508, 514	Safe brake check: Motor brake not controlled	
C2104		630	Command execution of command C2100 is not allowed, because command C6200 is active

Extended Diagnosis (P-0-3219) as of MPx07

Display	E-code channel 1 (P3219 [0])	E-code channel 2 (P3219 [1])	Safety technology error
C2107	1569		Safe brake check: Determined load due to weight greater than 1.3 * P-0-3303
	1559, 1560		Safe brake check: Test point holding torque of redundant holding brake incorrectly carried out in positive direction
	1564, 1565		Safe brake check: Test point holding torque of redundant holding brake incorrectly carried out in negative direction
		506	Safe brake check: When the force due to weight is determined, motion is expected when the brakes have been released. The drive did not move. A brake does not release although it is controlled
		511	Safe brake check: Redundant holding brake not released
		512	Safe brake check: Motor brake controlled
		514	Safe brake check: Motor brake not controlled
C2108	1541		Safe brake check: Channel 1 error-free, see error code channel 2
	1543		Safe brake check: Command C2100 is not allowed if "safe operation" is selected
	1545		Safe brake check: Axis did not move [or moved less than half the monitoring window ("P-0-3310" / 2)]
	1546		Safe brake check: Starting torque exceeded (P-0-0545 or P-0-0540 < P-0-0546)
	1542, 1544		"Safe brake check" error
	1545, 1547		Safe brake check: - Axis did not move (<P-0-3310/2) or - Axis moved too far (>P-0-3310*2)
		507	Safe brake check: Redundant holding brake not released
		508	Safe brake check: Motor brake not controlled
C2109	1551, 1556, 1561, 1566	582, 583	Safe brake check: Incorrect torque normalization <ul style="list-style-type: none"> • Replacement of motor (P-0-3304 ↔ P-0-0051) • Incorrect current measurement (P-0-0043)

Extended Diagnosis (P-0-3219) as of MPx07

12.3 Displays C4001, C4002 and C6201

If an error code is not contained in the documentation, please contact our service department.

Display	E-code channel 1 (P3219 [0])	E-code channel 2 (P3219 [1])	Safety technology error
C4001	1086		Channel 2 signals error for internal command "homing procedure channel 2" Cause: P-0-3280 deviates by more than one internal measuring-system-dependent threshold from S-0-0051/S-0-0053 or no homing input channel 2 configured in P-0-3211
		153	Command "safe homing procedure" was started although no reference input at channel 2 was configured in parameter P-0-3211
		157	Command "safe homing procedure" executed. Actual position value difference between channel 1 and channel 2 is greater than parameterized in P-0-3229
		163	Command "safe homing procedure" was started The actual position value systems of channel 1 and channel 2 were not synchronized beforehand; this is automatically carried out in the transition command from 3 to 4
C4002	1087		Incorrect distance of dedicated points of channel 1 and 2 [S-0-0052/54 - S-0-0150/151 - P-0-3231] > P-0-3229*1.1
C6201	1492		Channel 2 signals command not executable
	1493	625, 629	Command not executable, because it has not been enabled (P-0-3300) or safe braking and holding system has not been parameterized.
	1494	628	Command may only be started once after control voltage ON.
	1495	626	Command execution not allowed with active brake check (C2100).
	1496	627	Command execution only allowed with invalid brake status.

12.4 Displays Exxx, E3107 and E3115

If an error code is not contained in the documentation, please contact our service department.

Display	E-code channel 1 (P3219 [0])	E-code channel 2 (P3219 [1])	Safety technology error
Exxx	1xxx		In case of warning on channel 1, 1000 is added to the error code
E3107	1311		Safe reference is missing for monitoring in case of "Safely-limited position"
E3115	415, 417	254	Monitoring of time interval brake check Cause: Drive had been in "AF" for 15 minutes and brake check hasn't been carried out yet or the time defined in P-0-3302 was exceeded
	1416, 1418		Safe braking and holding system: "Prewarning, end of brake check time interval"

Extended Diagnosis (P-0-3219) as of MPx07

12.5 Displays F3112 to F3135

If an error code is not contained in the documentation, please contact our service department.

Display	E-code channel 1 (P3219 [0])	E-code channel 2 (P3219 [1])	Safety technology error
F3112	191		Special mode "safe motion" selected with "Safely-monitored position" without channel 2 having been homed
	312	179, 271	Safe reference is missing for monitoring in case of "Safely-limited position"
		155	Special mode "safe motion 1" selected with "Safely-monitored position" without channel 2 having been homed
		156	Special mode "safe motion 2" selected with "Safely-monitored position" without channel 2 having been homed
		283, 284	Missing safe reference for monitoring of "Safely-monitored position" in special mode "safe motion"
F3115	415, 417	254	Monitoring of time interval brake check: Cause: Drive had been in "AF" for 15 minutes and brake check hasn't been carried out yet or the time defined in P-0-3302 was exceeded
F3116	439	256	Monitoring of actual load torque: Nominal load torque of holding system exceeded
F3117	192		Validation error of actual position values channel 1 and 2 (in the case of safe reference)
		154, 666	Actual position value difference between channel 1 and channel 2 greater than determined internal measuring-system-dependent threshold
		158	With configuration "reference input channel 2 with static signal", 24 V were measured at the reference input outside of the tolerance window P-0-3231 +/- P-0-3229. Cause: Possibly short circuit to 24 V.
	723, 724		Encoder evaluation incorrect: Within the last 2s, the relative position value has not changed. Possible cause: Bad resolution so that actual position value (S-0-0051 or S-0-0053) does not change in last digit at standstill. Troubleshooting: Increase resolution (make max. travel range smaller, increase number of decimal places)

Extended Diagnosis (P-0-3219) as of MPx07

Display	E-code channel 1 (P3219 [0])	E-code channel 2 (P3219 [1])	Safety technology error
F3122		219	Command "apply redundant holding brake" was started. Brake could not be applied within 50 ms (diagnostic input at channel 2 (X41) at 24 V)
		221	The internal command "release redundant holding system" was started. Brake could not be released within 60 ms : <ul style="list-style-type: none"> • Diagnostic input at channel 2 (HSI11:X41) at 0 V • Error in HAT, i.e., 0 V at diagnostic input (HSI11:X41) • No voltage supply at connector X31
		223	During the command "resurfacing of redundant holding brake", the redundant holding system is applied. The brake, however, could not be applied within 200 ms (diagnostic input at channel 2 (X41) at 24 V)
		224	During the command "resurfacing of redundant holding brake", the redundant holding system is released. The brake, however, could not be released within 200 ms (diagnostic input at channel 2 (X41) at 0 V)
		505	Safe braking and holding system: Feedback signal from control module (HAT) is 0 V Cause: Missing connection between control module (HAT) and diagnostic input at connector X41 (HSI11) or Error in control module (HAT)
		532	Safe braking and holding system: Error in feedback signal of control module (HAT) Cause: Brake applied: Line interrupted, short circuit to 0 V or error message of control module (HAT) or Brake released: Short circuit to 24 V
F3123	432	518, 519, 556	Safe braking and holding system: No valid brake check status during transition to special mode
		533, 534	Safe braking and holding system: No valid brake check status during transition from parameter mode to operation mode with selection of special mode
		631	Safe braking and holding system: No valid brake check status in Safe operating stop
		632, 633, 634, 635	Safe braking and holding system: No valid brake check status in special mode "safe motion"

Extended Diagnosis (P-0-3219) as of MPx07

Display	E-code channel 1 (P3219 [0])	E-code channel 2 (P3219 [1])	Safety technology error
F3130	23		Not all input signals of channel 1 are at low level during dynamization pulse
		26	During dynamization of input E1n of channel 2, the input does not go to 0 V. Cause: Short circuit between input E1n and 24 V.
		28	During dynamization of input E2n of channel 2, the input does not go to 0 V. Cause: Short circuit between input E2n and 24 V.
		29	During dynamization of input E3n of channel 2, the input does not go to 0 V. Cause: Short circuit between input E3n and 24 V.
		35	During dynamization of input E4n of channel 2, the input does not go to 0 V. Cause: Short circuit between input E4n and 24 V.

Extended Diagnosis (P-0-3219) as of MPx07

Display	E-code channel 1 (P3219 [0])	E-code channel 2 (P3219 [1])	Safety technology error
F3131	24	48	EA20 is statically at low level. Cause: Short circuit to GND or EA20 not connected or power supply at X41 missing
	151		Diagnostic/acknowledgment slave: EA20 does not toggle during initialization in operation mode (after phase progression or clear error). Cause: +24 V are missing at X41 or short circuit to V+ or GND
	152	125, 141, 160	Diagnostic/acknowledgment slave: EA20 is statically at low level. Cause: Short circuit to 0 V or EA20 not connected or power supply at X41 missing
	153		Diagnostic/acknowledgment slave: It was impossible to set EA20 to high level (it toggles)
	154		Diagnostic/acknowledgment slave: It was impossible to set EA20 to high level
	155	124, 150	Diagnostic/acknowledgment slave: EA20 is permanently at high level. Cause: Either by master or by short circuit to 24 V
	161	46	Diagnostic/acknowledgment master: EA20 does not toggle during initialization in operation mode (after phase progression or clear error). Cause: One module in the group with non-activated safety technology or short circuit EA20 to 24 V
	163		Diagnostic/acknowledgment master: It was impossible to set EA20 to high level
	164		Diagnostic/acknowledgment master: EA20 at high level longer than 600 ms during acknowledgment request
	167		Diagnostic/acknowledgment master: EA20 does not toggle when safety door is locked
	170		Diagnostic/acknowledgment master: EA20 does not toggle when safety door is unlocked
	171	174	Single axis for diagnosis/acknowledgment: EA20 at low level for more than 10 ms (EA20 should be permanently at 24 V). Cause: 24 V supply missing at X41 or short circuit EA20 to 0 V
		49	Diagnostic/acknowledgment master: EA20 does not toggle during initialization in operation mode (after phase progression or clear error). Cause: No voltage supply at X41 or short circuit EA20 to 0 V
		124	Diagnostic/acknowledgment master: EA20 is permanently at high level. Cause: One module in the group with non-activated safety technology or short circuit EA20 to 24 V
	129	Diagnostic/acknowledgment slave: EA20 does not toggle. Cause: One module in the group with non-activated safety technology or short circuit EA20 to 24 V	
	142	Safety door unlocked or diagnostic output at "safe" under PLC control although safety of zone does not exist	

Extended Diagnosis (P-0-3219) as of MPx07

Display	E-code channel 1 (P3219 [0])	E-code channel 2 (P3219 [1])	Safety technology error
F3132 ...	166		Diagnostic/acknowledgment master: A10 cannot be set to low level when safety door is locked
	169		Diagnostic/acknowledgment master: A10 cannot be set to high level when safety door is unlocked
	172		Single axis for diagnosis/acknowledgment: Channel 1 acknowledges safety and channel 2 does not. (A10 and A10n at high level)
	173		Single axis for diagnosis/acknowledgment: Channel 2 acknowledges safety and channel 1 does not. (A10 and A10n at low level)
	335		Safe output has been activated/set; after a tolerance time of 2 seconds, feedback at check input E10 is missing (P-0-3212, bit 9 = high for t > 10ms)
	336		Safe output has been deactivated/reset; after a tolerance time of 2 seconds, feedback at check input E10 is still present (P-0-3212, bit 9 = low for t > 10 ms)
	338	780	Short circuit between X3x.x and X41.2 with activated safe output (P-P-switching)
	168		Diagnostic/acknowledgment master: E10 has low level at end of unlocking of safety door
	165		Diagnostic/acknowledgment master: E10 has high level at end of locking of safety door
	640		Monitoring diagnostic output A10: In UNSAFE state, the digital output (see P-0-30x) was at high level for more than 100 ms (e.g., by short circuit)
	641		Monitoring diagnostic output A10: In SAFE state, the digital output (see P-0-30x) was at low level for more than 100 ms (e.g., by short circuit)
		126	Diagnostic master/slave with PLC control: During transition to normal operation, EA10n cannot be set to 24 V (Short circuit EA10n to 0 V)
		127	In safe state and control of a safety door: EA10n does not detect 24 V at A10. Remedy: Check wiring in control circuit, contactor for control of safety door defective
		128	In safe state, EA10n (with configuration of a PLC control) cannot be set to low level. Cause: EA10n has short circuit to 24 V or error in wiring
		143	Error in control of safety door. Cause: EA10n defective or feedback via E10 missing
	201	Activation safe output: Control of channel 2 has not taken place within one second Cause: Internal relay defective or output EA10n is at 24 V	

Extended Diagnosis (P-0-3219) as of MPx07

Display	E-code channel 1 (P3219 [0])	E-code channel 2 (P3219 [1])	Safety technology error
... F3132		206	Activation safe output: The drive is not able to switch to the active state within 1s. Remedy: Check wiring in control circuit and feedback circuit (input E10 = 0 V)
		209	Activation safe output: Control of channel 1 via A10 has not taken place within one second
		146, 176	In unsafe state, EA10n cannot be set to high level
		147, 175	In safe state, EA10n cannot be set to low level
		202, 204	Activation safe output: After activated state has been reached, this status is permanently checked. An error was detected during this check. Remedy: Check wiring in control circuit and feedback circuit (input E10 = 0 V)
		207, 208	Deactivation safe output: After safe state has been reached at load circuit, this status is permanently checked. An error was detected during this check. Remedy: Check wiring in control circuit and feedback circuit (input E10 = 24V)
		211, 212	Deactivation safe output: Upon request, drive is not able to switch load circuit to safe state within two seconds. Cause: Incorrect control of channel 2 or feedback via channel 1 not ok (input E10 = 24 V)
		780	Short circuit between X3x.x and X41.2 with activated safe output (P-P-switching)
F3134	109		Interval "dynamization of safety function selection" (EA30 EDynK1) is greater than P-0-3223 * 1.2
	111, 117	63	Interval of dynamization signal (EA30 or -P0-3212, bit 10) exceeded (P-0-3223)
		139	In synchronization phase of dynamization during transition to operation mode, dynamization signal is longer than 1.5-fold time of P-0-3223 at 24 V
F3135	108		Pulse width of dynamization signal (EA30 or P-0-3212, bit 10) shorter than minimum pulse width of 30 ms
	98, 99, 116	57	Pulse width of dynamization signal (EA30 or P-0-3212, bit 10) greater than P-0-3224
		64	Dynamization pulse at EA30 smaller than minimum pulse width (30 ms)
		140	In synchronization phase of dynamization during transition to operating mode, dynamization signal is longer than 1.5-fold time of P-0-3224 at 0 V

Extended Diagnosis (P-0-3219) as of MPx07

12.6 Display F3140

If an error code is not contained in the documentation, please contact our service department.

Display	E-code channel 1 (P3219 [0])	E-code channel 2 (P3219 [1])	Safety technology error
F3140 ...	53		P-0-3205 of channels 1 and 2 are different
	54	426	P-0-3291 of channels 1 and 2 are different
	55	425	P-0-3290 of channels 1 and 2 are different
	56	404	P-0-3210 of channels 1 and 2 are different
	57		P-0-3211 of channels 1 and 2 are different
	58		P-0-3240, P-0-3250, P-0-3260 and P-0-3270 of channels 1 and 2 are different
	77	439	P-0-3239 of channels 1 and 2 are different
	78	440	P-0-3295 of channels 1 and 2 are different
... F3140 ...	79	441	P-0-3200 of channels 1 and 2 are different
	120	363, 364, 365	P-0-3220 of channels 1 and 2 are different
	121	369, 370, 371	P-0-3221 of channels 1 and 2 are different
	122	366, 367, 368	P-0-3222 of channels 1 and 2 are different
	123	387, 388, 389	P-0-3223 of channels 1 and 2 are different
	124	390, 391, 392	P-0-3224 of channels 1 and 2 are different
	125	418, 419, 420	P-0-3225 of channels 1 and 2 are different
	126	414, 415, 416	P-0-3234 of channels 1 and 2 are different
	127	422, 423, 424	P-0-3229 of channels 1 and 2 are different
	128	360, 361, 362	P-0-3230 of channels 1 and 2 are different
	129	372, 373, 374	P-0-3231 of channels 1 and 2 are different
	130	393, 394, 395	P-0-3232 of channels 1 and 2 are different
	131	410, 411, 412	P-0-3233 of channels 1 and 2 are different

Extended Diagnosis (P-0-3219) as of MPx07

Display	E-code channel 1 (P3219 [0])	E-code channel 2 (P3219 [1])	Safety technology error
	132	348, 349, 350	P-0-3241 of channels 1 and 2 are different
	133	351, 352, 353	P-0-3242 of channels 1 and 2 are different
	134	336, 337, 338	P-0-3243 of channels 1 and 2 are different
	135	324, 325, 326	P-0-3244 of channels 1 and 2 are different
	136	703	P-0-3247 of channels 1 and 2 are different
	137	354, 355, 356	P-0-3251 of channels 1 and 2 are different
	138	357, 358, 359	P-0-3252 of channels 1 and 2 are different
	139	339, 340, 341	P-0-3253 of channels 1 and 2 are different
	140	327, 328, 329	P-0-3254 of channels 1 and 2 are different
	141	705	P-0-3257 of channels 1 and 2 are different
...	142	342, 343, 344	P-0-3263 of channels 1 and 2 are different
F3140	143	330, 331, 332	P-0-3264 of channels 1 and 2 are different
...	144	707	P-0-3267 of channels 1 and 2 are different
	145	345, 346, 347	P-0-3273 of channels 1 and 2 are different
	146	333, 334, 335	P-0-3274 of channels 1 and 2 are different
	147	709	P-0-3277 of channels 1 and 2 are different
	148	428, 429, 430	P-0-3282 of channels 1 and 2 are different
	149	432, 433, 434	P-0-3235 of channels 1 and 2 are different
	150	436, 437, 438	P-0-3236 of channels 1 and 2 are different
	350	442, 443, 444	P-0-3302 of channels 1 and 2 are different
	351	450, 451, 452	P-0-3306 of channels 1 and 2 are different
	352	454, 455, 456	P-0-3307 of channels 1 and 2 are different

Extended Diagnosis (P-0-3219) as of MPx07

Display	E-code channel 1 (P3219 [0])	E-code channel 2 (P3219 [1])	Safety technology error
	353	462, 463, 464	P-0-3311 of channels 1 and 2 are different
	354	466, 467, 468	P-0-3226 of channels 1 and 2 are different
	355	470, 471, 472	P-0-3246 of channels 1 and 2 are different
	356	474, 475, 476	P-0-3256 of channels 1 and 2 are different
	357	478, 479, 480	P-0-3266 of channels 1 and 2 are different
	358	482, 483, 484	P-0-3276 of channels 1 and 2 are different
	359	711, 713	P-0-3248 of channels 1 and 2 are different
	360	714, 716	P-0-3258 of channels 1 and 2 are different
	361	717, 719	P-0-3268 of channels 1 and 2 are different
	362	720, 722	P-0-3278 of channels 1 and 2 are different
	363	694, 695, 696	P-0-3305 of channels 1 and 2 are different
...	368	432, 433, 434	P-0-3235 of channels 1 and 2 are different
F3140	369	436, 437, 438	P-0-3236 of channels 1 and 2 are different
	370	446, 447, 448	P-0-3303 of channels 1 and 2 are different
	371	458, 459, 460	P-0-3310 of channels 1 and 2 are different
	372	486, 487, 488	P-0-3304 of channels 1 and 2 are different
		405	P-0-3240 of channels 1 and 2 are different
		406	P-0-3250 of channels 1 and 2 are different
		407	P-0-3260 of channels 1 and 2 are different
		408	P-0-3270 of channels 1 and 2 are different
		396, 400	P-0-3211 (input E1n) of channels 1 and 2 are different
		397, 401	P-0-3211 (input E2n) of channels 1 and 2 are different
		398, 402	P-0-3211 (input E3n) of channels 1 and 2 are different
		399, 403	P-0-3211 (input E4n) of channels 1 and 2 are different
	670	692	P-0-3316 of channels 1 and 2 are different
	672	693	P-0-3317 of channels 1 and 2 are different

12.7 Displays F3141 and F3142

If an error code is not contained in the documentation, please contact our service department.

Display	E-code channel 1 (P3219 [0])	E-code channel 2 (P3219 [1])	Safety technology error
F3141	3	58	Selection validation error: Signal "MS" of channels 1 and 2 is unequal
	200	59	Selection validation error: Signal "ES" of channels 1 and 2 is unequal
	201	60	Selection validation error: Signal "EC" of channels 1 and 2 is unequal
	202	61	Selection validation error: Signal "S1" of channels 1 and 2 is unequal
	203	62	Selection validation error: Signal "S2" of channels 1 and 2 is unequal
	330	195	Selection validation error: Signal "safe input 1" of channels 1 and 2 is unequal
	331	196	Selection validation error: Signal "safe input 2" of channels 1 and 2 is unequal
	332	197	Selection validation error: Signal "safe input 3" of channels 1 and 2 is unequal
	333	198	Selection validation error: Signal "safe input 4" of channels 1 and 2 is unequal
	334	199	Selection validation error: Signal "safe output" of channels 1 and 2 is unequal
F3142	35		Activation time of enabling control (P-0-3222) exceeded in special mode "safe motion"
	37		Activation time of enabling control exceeded (P-0-3246/P-0-3256/P-0-3266/P-0-3276)
		68	Activation time of enabling control (P-0-3222) exceeded
		578	Individual activation time of enabling control (P-0-3246) exceeded when selecting special mode "safe motion 1"
		579	Individual activation time of enabling control (P-0-3256) exceeded when selecting special mode "safe motion 2"
		580	Individual activation time of enabling control (P-0-3266) exceeded when selecting special mode "safe motion 3"
		581	Individual activation time of enabling control (P-0-3276) exceeded when selecting special mode "safe motion 4"

Extended Diagnosis (P-0-3219) as of MPx07

12.8 Displays F3144 to F3152

If an error code is not contained in the documentation, please contact our service department.

Display	E-code channel 1 (P3219 [0])	E-code channel 2 (P3219 [1])	Safety technology error
F3144 ...	76	173	"Deactivation of acknowledgment support: single acknowledgment" and "master for diagnosis and acknowledgment" (in P-0-3210) configured; this is not allowed
	499	585	Configuration error: Switch drive to P2, clear error and switch to P4 again; C0256 is then signaled with corresponding error code in P-0-3219
	727		Configuration error: Parameter set switching of the group "load gear" is not allowed with load reference, when "Scaling of the safety parameters according to setting of scaling system with deactivated gear independence" has been configured in P-0-3210.
	728		Configuration error: When "Scaling of the safety parameters according to setting of scaling system with deactivated gear independence" has been configured in P-0-3210, parameter set switching of the group "load gear" is not allowed, if the safety technology encoder is the external encoder mounted on the load side.
	730	783	The function "Safely-limited position" (SLP) is only allowed in conjunction with the function "Safe maximum speed" (SMS).
	732		Configuration "Scaling of the safety parameters with relation to the motor shaft" and "Safety technology encoder is not the motor encoder" is not allowed.
	733		An undefined configuration (bit15="1" and bit14="1") has been set in P-0-3210.
	734		Configuration error: Parameter set switching of group "load gear" is not allowed if "Redundant holding brake available" (bit 0="1") is configured in P-0-3300 and "Load reference" is set in S-0-0086
		5	Mode selector was configured twice in P-0-3211
		6	"SS1 (Emergency stop) switch" was configured twice in P-0-3211
		7	Enabling control was configured twice in P-0-3211
		8	Home switch was configured twice in P-0-3211
		9	Safety switch 1 was configured twice in P-0-3211
		10	Safety switch 2 was configured twice in P-0-3211
		12	No valid configuration in P-0-3211
		184	Mode selector was parameterized in P-0-3211, this is not allowed when using PROFIsafe
		185	"SS1 (Emergency stop) switch" was parameterized in P-0-3211, this is not allowed when using PROFIsafe
		186	Enabling control was parameterized in P-0-3211, this is not allowed when using PROFIsafe
	187	Home switch was configured twice in P-0-3211	

Extended Diagnosis (P-0-3219) as of MPx07

Display	E-code channel 1 (P3219 [0])	E-code channel 2 (P3219 [1])	Safety technology error
... F3144		188	Safety switch 1 was parameterized in P-0-3211; this is not allowed when using PROFIsafe
		189	Safety switch 2 was parameterized in P-0-3211; this is not allowed when using PROFIsafe
		190	"Safe input 1" was configured twice in P-0-3211
		191	"Safe input 2" was configured twice in P-0-3211
		192	"Safe input 3" was configured twice in P-0-3211
		193	"Safe input 4" was configured twice in P-0-3211
		215	Diagnostic input of redundant holding brake was configured twice in P-0-3211
		216	Safe braking and holding system parameterized, but no diagnostic input was configured for channel 2 in P-0-3211
		490	Configuration error: "Safely-monitored position" and "gear independence with safety technology encoder mounted on the load side" not allowed
		491	Configuration error: "Safely-limited position" and "gear independence with safety technology encoder mounted on the load side" not allowed
		492	Configuration error: "Safe braking and holding system" and "gear independence with safety technology encoder mounted on the load side" not allowed
		609	Configuration error: Both directions (P-0-3300 bit 9/10) were parameterized as direction input for the brake check
		180, 181, 182, 183	Configuration error: Safe input 1-4 is only possible in conjunction with PROFIsafe
		568, 572	Monitoring for direction of motion was parameterized differently in P-0-3239 and P-0-3240
		569, 573	Monitoring for direction of motion was parameterized differently in P-0-3239 and P-0-3250
		570, 574	Monitoring for direction of motion was parameterized differently in P-0-3239 and P-0-3260
		571, 575	Monitoring for direction of motion was parameterized differently in P-0-3239 and P-0-3270
		681, 682, 683, 684, 685, 686, 687, 688, 689, 690, 691	Configuration error: Monitoring for direction of motion in P-0-3239 not plausible
F3145		67	Diagnostic master with control of safety door. During transition to normal operation, the door cannot be locked. Cause: Error in wiring of safety door or short circuit between EA10n, A10, E10 and 24 V

Extended Diagnosis (P-0-3219) as of MPx07

Display	E-code channel 1 (P3219 [0])	E-code channel 2 (P3219 [1])	Safety technology error
F3146		47	Difference in measuring system between incremental and analog system is greater than 1/4 division period
		66	During measuring system evaluation, two active counting edges were detected. The information no longer is unequivocal (position error)
		120, 121	Incorrect encoder signals. Amplitude monitoring
		33, 43, 604, 605	Encoder type is not supported by channel 2
F3147	299		Danger to persons! The firmware used is a test version and the specific safety technology firmware test was not carried out for this firmware. It is only provided for a limited time and restricted applications. Contact our service department.
	419		Safe braking and holding system: Axis moved too far during brake check (> P-0-3310 * 2)
	483		Encoder signals incorrect: Amplitude monitoring, pointer length too small.
	484		Encoder signals incorrect: Amplitude monitoring, pointer length too big.
	485		Encoder signals incorrect: Quadrant error
F3152	47	172, 200	Safety parameters cannot be stored in the safety memory (wrong version) (Invalid parameter set, probably of a previous version)

12.9 Displays F7010 to F7022

If an error code is not contained in the documentation, please contact our service department.

Display	E-code channel 1 (P3219 [0])	E-code channel 2 (P3219 [1])	Safety technology error
F7010	9	69	P-0-3243 exceeded in special mode "safe motion 1"
	14	90	P-0-3253 exceeded in special mode "safe motion 2"
	19	93	P-0-3263 exceeded in special mode "safe motion 3"
	22	94	P-0-3273 exceeded in special mode "safe motion 4"
F7011	10	88	P-0-3241 exceeded in special mode "safe motion 1"
	15	91	P-0-3251 exceeded in special mode "safe motion 2"
F7012	11	89	P-0-3242 exceeded in special mode "safe motion 1"
	16	92	P-0-3252 exceeded in special mode "safe motion 2"

Extended Diagnosis (P-0-3219) as of MPx07

Display	E-code channel 1 (P3219 [0])	E-code channel 2 (P3219 [1])	Safety technology error
F7013	7	1	P-0-3244 exceeded in special mode "safe motion 1"
	12	11	P-0-3254 exceeded in special mode "safe motion 2"
	17	18	P-0-3264 exceeded in special mode "safe motion 3"
	20	22	P-0-3274 exceeded in special mode "safe motion 4"
F7014	661	699	P-0-3247 exceeded longer than P-0-3248 in special mode "safe motion 1"
	662	700	P-0-3257 exceeded longer than P-0-3258 in special mode "safe motion 2"
	663	701	P-0-3267 exceeded longer than P-0-3268 in special mode "safe motion 3"
	664	702	P-0-3277 exceeded longer than P-0-3278 in special mode "safe motion 4"
F7020	94	133	P-0-3234 was exceeded
	731	782	Safely-limited position (SLP): P-0-3234 exceeded. When safe reference is not available, the drive may only be moved at a maximum of 20% of P-0-3234
F7021	313	177	P-0-3235 was exceeded
	314	178	P-0-3236 was exceeded
	315, 327		"Safely-limited position" was exceeded: Tracked threshold was exceeded by more than P-0-3232 Position polarity, inverted → Safely-limited position, positive Otherwise → Safely-limited position, negative
	316, 328		"Safely-limited position" was exceeded: Tracked threshold was exceeded by more than P-0-3232 Position polarity, inverted → Safely-limited position, negative Otherwise → Safely-limited position, positive
	319, 321		"Safely-limited position" was exceeded: Command values point to forbidden direction Position polarity, inverted → Safely-limited position, positive Otherwise → Safely-limited position, negative
	320, 322		"Safely-limited position" was exceeded: Command values point to forbidden direction Position polarity, inverted → Safely-limited position, negative Otherwise → Safely-limited position, positive
F7022	431		Missing feedback or brake controlled with drive enable missing

12.10 Displays F7030 to F7031

If an error code is not contained in the documentation, please contact our service department.

Extended Diagnosis (P-0-3219) as of MPx07

Display	E-code channel 1 (P3219 [0])	E-code channel 2 (P3219 [1])	Safety technology error
F7030	194		P-0-0048 > P-0-3233 in "Safe stop 2"
	197		Operation mode position control: Derived position command value > P-0-3233 "Safe stop 2"
	4, 196	97, 98, 265, 266	P-0-3230 exceeded in safety technology function "Safe stop 2"
F7031	5	576	P-0-3232 exceeded in negative direction in special mode "safe motion"
	6	577	P-0-3232 exceeded in positive direction in special mode "safe motion"
	588		Positive monitoring of direction of motion has detected motion in negative direction (> P-0-3232)
	589		Negative monitoring of direction of motion has detected motion in positive direction (> P-0-3232)
	650	679	P-0-3232 exceeded in negative direction in normal operation
	651	680	P-0-3232 exceeded in positive direction in normal operation
		101	P-0-3232 exceeded in positive direction in special mode "safe motion 4"
		102	P-0-3232 exceeded in negative direction in special mode "safe motion 4"
		103	P-0-3232 exceeded in positive direction in special mode "safe motion 3"
		104	P-0-3232 exceeded in negative direction in special mode "safe motion 3"
		105	P-0-3232 exceeded in positive direction in special mode "safe motion 2"
		106	P-0-3232 exceeded in negative direction in special mode "safe motion 2"
		107	P-0-3232 exceeded in positive direction in special mode "safe motion 1"
	108	P-0-3232 exceeded in negative direction in special mode "safe motion 1"	

Extended Diagnosis (P-0-3219) as of MPx07

12.11 Displays F7040 to F7043

If an error code is not contained in the documentation, please contact our service department.

Display	E-code channel 1 (P3219 [0])	E-code channel 2 (P3219 [1])	Safety technology error
F7040 ...	226		Validation error parameterized - effective threshold P-0-3234
	236	704	Validation error parameterized - effective threshold P-0-3247
	241	706	Validation error parameterized - effective threshold P-0-3257
	244	708	Validation error parameterized - effective threshold P-0-3267
	247	710	Validation error parameterized - effective threshold P-0-3277
	249	431	Validation error parameterized - effective threshold P-0-3235
	250	435	Validation error parameterized - effective threshold P-0-3236
	251, 470	449	Validation error parameterized - effective threshold P-0-3303
	252, 471	461	Validation error parameterized - effective threshold P-0-3310
	253, 472	489	Validation error parameterized - effective threshold P-0-3304
	450	445	Validation error parameterized - effective threshold P-0-3302
	451	453	Validation error parameterized - effective threshold P-0-3306
	452	457	Validation error parameterized - effective threshold P-0-3307
	453	465	Validation error parameterized - effective threshold P-0-3311
	454	469	Validation error parameterized - effective threshold P-0-3226
	455	473	Validation error parameterized - effective threshold P-0-3246
	456	477	Validation error parameterized - effective threshold P-0-3256
	457	481	Validation error parameterized - effective threshold P-0-3266
	458	485	Validation error parameterized - effective threshold P-0-3276
	459	712	Validation error parameterized - effective threshold P-0-3248
	460	715	Validation error parameterized - effective threshold P-0-3258
	461	718	Validation error parameterized - effective threshold P-0-3268
	462	721	Validation error parameterized - effective threshold P-0-3278
	463		Validation error parameterized - effective threshold P-0-3305
	468	431	Validation error parameterized - effective threshold P-0-3235
	469	435	Validation error parameterized - effective threshold P-0-3236
		324, 325, 326	P-0-3244 of channels 1 and 2 are different
		327, 328, 329	P-0-3254 of channels 1 and 2 are different
		410, 411, 412	P-0-3233 of channels 1 and 2 are different

Extended Diagnosis (P-0-3219) as of MPx07

Display	E-code channel 1 (P3219 [0])	E-code channel 2 (P3219 [1])	Safety technology error
...	709, 710, 715	653, 654, 655	Change in scaling or number of decimal places of position parameters
	711, 716	656, 657	Change in scaling or number of decimal places of velocity parameters
	712, 717	658, 659	Change in scaling or number of decimal places of acceleration parameters
	713, 718	660, 661	Change in scaling or number of decimal places of parameter P-0-3303
	714, 719	662, 663	Change in scaling or number of decimal places of parameter P-0-3304
	739		Encoder type has changed
	800, 801		Encoder configuration, position scaling or multiplication (S-0-0256 / S-0-0257) has changed
		416	P-0-3234 of channels 1 and 2 are different
F7043		295	Output stage cannot be switched on via channel 2 during transition from "Safe stop 1 (Emergency stop)" or "Safe stop 1" to a special mode
		267, 500	Output stage cannot be switched on via channel 2 during transition to normal operation
		643, 781	Output stage cannot be switched on via channel 2 in normal operation
		644, 645, 646, 647, 648	Output stage cannot be switched on via channel 2 in special mode

12.12 Displays F7050 to F7051

If an error code is not contained in the documentation, please contact our service department.

Display	E-code channel 1 (P3219 [0])	E-code channel 2 (P3219 [1])	Safety technology error
F7050	27		Time for safe stopping process exceeded during transition to "Safe stop 1" Cause: Actual velocity value > P-0-3233 or drive enable still set
	28		Time for safe stopping process exceeded during transition to "Safe stop 1 (Emergency stop)" Cause: Actual velocity value > P-0-3233 or drive enable still set
	32		Time for safe stopping process exceeded during transition to "Safe stop 2" (Actual velocity value > P-0-3233)
	90		Time for safe stopping process exceeded (P-0-3220 or P-0-3225) during transition to parameter mode
	91		Time for safe stopping process exceeded during transition to internal error state "Safe stop 1" error (the error reaction could not remove drive enable within the time P-0-3220/P-0-3225)
		601	Configuration error: P-0-0117="1" (NC error reaction activated; with F3 error) and transition time (P-0-3220/P-0-3225) parameterized smaller than 30 s
		123, 290	Time for safe stopping process (P-0-3220) exceeded during transition to "Safe stop 1" or "Safe stop 1 (Emergency stop)" Cause: Actual velocity value > P-0-3233 or drive enable still set
		134, 288	Time for safe stopping process (P-0-3225) exceeded during transition to "Safe stop 1" or "Safe stop 1 (Emergency stop)" Cause: Actual velocity value > P-0-3233 or drive enable still set
		144, 557	Time for safe stopping process exceeded (P-0-3220) during transition to "Safe stop 2" Cause: Actual velocity value > P-0-3233
	145, 286	Time for safe stopping process exceeded (P-0-3225) during transition to "Safe stop 2" Cause: Actual velocity value > P-0-3233	

Extended Diagnosis (P-0-3219) as of MPx07

Display	E-code channel 1 (P3219 [0])	E-code channel 2 (P3219 [1])	Safety technology error
F7051	411		Safe braking and holding system: When decelerating with "velocity command value reset with ramp and filter", the deceleration ramp has fallen below the value set in P-0-3282
	205, 208, 217		In the safety technology function "Safe stop 1", the deceleration ramp has fallen below the value set for safely-monitored deceleration (P-0-3282)
	206, 209, 218		In the safety technology function "Safe stop 2", the deceleration ramp has fallen below the value set for safely-monitored deceleration (P-0-3282)
	207, 210, 219		In the safety technology function "Safe stop 1 (Emergency stop)", the deceleration ramp has fallen below the value set for safely-monitored deceleration (P-0-3282)
	270		During the transition to "Safe stop 1" error, the deceleration ramp has fallen below the value set for safely-monitored deceleration (P-0-3282)
		502, 622	During best possible deceleration, drive is not able to come to standstill within P-0-3282
		547	Drive is not able to come to standstill within the parameterized monitoring limits
		559	Drive is not able to come to the special mode motion within the parameterized monitoring limits (P-0-3225 or P-0-3220, P-0-3282)
		563, 624	During NC-controlled transition to the special mode "safe standstill" [after delay was over (P-0-3226)], drive is not able to come to standstill within the parameterized monitoring limits (P-0-3225 or P-0-3220, P-0-3282)
		161	In the function "Safely-monitored deceleration" during transition from normal operation to "Safe stop 1"/"Safe stop 2", drive is not able, within the scope of possible acceleration, to reach standstill within transition time P-0-3220
		162	In the function "Safely-monitored deceleration" during transition from safe operation to "Safe stop 1"/"Safe stop 2", drive is not able, within the scope of possible acceleration, to reach standstill within transition time P-0-3225
		565, 589	During drive-controlled stopping process, drive is not able to come to standstill within P-0-3282
		618, 621	During drive-controlled stopping process, drive is not able to come to standstill within P-0-3282. Error is generated before P-0-3226 is over
		636	During NC-controlled transition to the special mode "safe standstill" [before delay was over (P-0-3226)], drive is not able to come to standstill within the parameterized monitoring limits (P-0-3225 or P-0-3220, P-0-3282)

Extended Diagnosis (P-0-3219) as of MPx07

12.13 Displays F8030 to F8135

If an error code is not contained in the documentation, please contact our service department.

Display	E-code channel 1 (P3219 [0])	E-code channel 2 (P3219 [1])	Safety technology error
F8030	113		Drive enable is set in internal error status "Safe stop 1" error
	114	637, 642	Drive enable is set in safety technology function "Safe stop 1"
	115	638, 641	Drive enable is set in safety technology function "Safe stop 1 (Emergency stop)"
	303	639	Drive enable is set with "parking axis"
		669	Drive enable is still set during transition to "Safe stop 1 (SS1)"
		670	Drive enable is still set during transition to "Safe stop 1 (Emergency stop) (SS1ES)"
F8134	273		During the transition to "Safe stop 1" error, the deceleration ramp has fallen below the value set in P-0-3282
	405		Safe braking and holding system: Missing feedback or brake controlled with drive enable missing
	406		Safe braking and holding system: Missing control of redundant holding brake without drive enable in standstill
	408		Safe braking and holding system: Missing control of motor holding brake ("P-0-3307, Safety technology - drive off delay time" is running)
		235, 542	Motor brake or redundant holding brake released, although output stage is not active Remedy: Check control of brakes
F8135	205		In the safety technology function "Safe stop 1", the deceleration ramp has fallen below the value set for safely-monitored deceleration (P-0-3282)
	207		In the safety technology function "Safe stop 1 (Emergency stop)", the deceleration ramp has fallen below the value set for safely-monitored deceleration (P-0-3282)
	272	566, 567, 586	During the transition to "Safe stop 1" error, the deceleration ramp has fallen below the value set in P-0-3282
	273		F7 error reaction: During the transition to "Safe stop 1" error, the deceleration ramp has fallen below the value set in P-0-3282
	407		Safe braking and holding system: Missing control of redundant holding brake without drive enable Cause: Delay by motor holding brake is not sufficient
	410		Time for safe stopping process exceeded, the error reaction could not remove drive enable within the time P-0-3220/P-0-3225 Remedy: Check parameterization in P-0-3220/P-0-3225 and S-0-0207
	412, 413	546, 623	Safe braking and holding system: When decelerating with "velocity command value reset", the deceleration ramp has fallen below the value set in P-0-3282
		619, 620	In the case of error, the drive is not able, during drive-controlled stopping process, to come to standstill within the parameterized monitoring limits. Error is generated before P-0-3226 is over.

Extended Diagnosis (P-0-3219) as of MPx07

12.14 Display F8201

If an error code is not contained in the documentation, please contact our service department.

Display	E-code channel 1 (P3219 [0])	E-code channel 2 (P3219 [1])	Safety technology error
F8201		159	Version of safety memory does not match firmware . Remedy: Execute C0720 and then reload and store safety technology parameters
	610, 611, 612, 613, 614, 615, 616		HW configuration check: The control section has not been released for operation with the active safety technology firmware. Remedy: Replace control section
	620, 621, 622, 623, 624, 625, 626		HW configuration check: Optional safety technology module has not been released for operation with the active safety technology firmware. Remedy: Replace control section
	630, 631, 632, 633, 634, 635, 636		HW configuration check: Optional encoder module has not been released for operation with the active safety technology firmware. Remedy: Replace control section

13 Rexroth IndraDrive Mi Diagnostic Display

13.1 KSM Distributed Servo Drive / KMS Distributed Drive Controller

13.1.1 LED H14

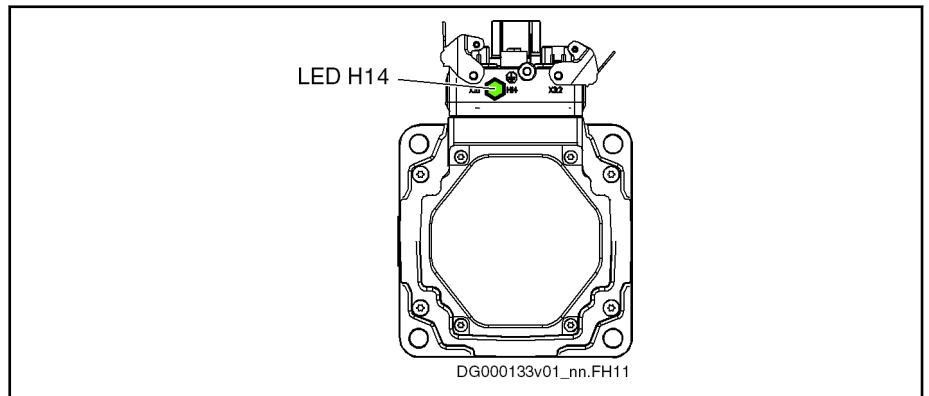





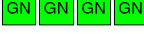





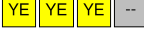

Fig. 13-1: LED H14 (Example KSM)

At the device, there is a tricolor LED which displays the drive status.

13.1.2 Diagnostic Display as of MPB-07V12 / MPx-08VRS

LED H14 Color / flashing pattern		Significance	Measures
	Off 	Supply unit not switched on	Check supply unit and, if necessary, switch it on
		Cable interrupted	Check cable and connector
		Hardware defective	Replace hardware
	Flashing green 	Drive is error-free (phases 2, 3 and 4); in phase 4, drive is ready for drive enable ("Bb")	If necessary, read exact status via "S-0-0095, Diagnostic message"
	Green 	Power on and DC bus voltage available ("Ab")	Drive is error-free in operation and runs according to inputs NOTICE! If you remove the connectors from the device in this status, this might damage the device!
		Drive in control ["AF", "AH" or drive command active (Cxxxx)]	
	Flashing green-yellow 	Transition command (C01xx/C52xx) Transition command error (C01xx/C02xx)	If necessary, read exact status via "S-0-0095, Diagnostic message"
		Drive command error (Cxxxx)	
	Flashing yellow 	Drive warning (E2xxx ... E3xxx) Communication warning (E4xxx)	Read exact status via "S-0-0095, Diagnostic message" and carry out service function
		Fatal warning (E8xxx)	

Rexroth IndraDrive Mi Diagnostic Display













LED H14 Color / flashing pattern		Significance	Measures
	Yellow 	Firmware update running	During the firmware update, do not interrupt the 24V supply and do not unplug connectors
	Flashing red-yellow 	Drive is error-free (phase 1), but not yet ready for drive enable ("Bb")	If necessary, read exact status via "S-0-0095, Diagnostic message"
		Communication error (F4xxx)	
	Flashing red-green 	Baud rate scan (P-1)	If necessary, read exact status via "S-0-0095, Diagnostic message"
		Drive is error-free (phase 0), but not yet ready for drive enable ("Bb")	
	Flashing red 	Error (F2xxx, F3xxx, F6xxx, F7xxx, F8xxx)	Read exact status via "S-0-0095, Diagnostic message" and carry out service function
	Red 	Booting phase	Wait until booting phase is over (approx. 2 minutes)
		System error (F9xxx, E0800)	Switch off and on; replace hardware, if necessary

Fig. 13-2: LED Displays KSM/KMS (as of MPB-07V12 / MPx-08VRS)

13.1.3 Diagnostic Display up to MPB-07V10







LED H14 Color / status		Significance	Measures
	Off	Supply unit not switched on	Check supply unit and, if necessary, switch it on
		Cable interrupted	Check cable and connector
		Hardware defective	Replace hardware
	Flashing green	Drive is error-free, but not yet ready for drive enable ("Bb")	If necessary, read exact status via "S-0-0095, Diagnostic message"
		Parameter Mode	
	Green	Drive in control ("AF", "AH" or drive command)	Drive is error-free in operation and runs according to inputs NOTE! If you remove the connectors from the device in this status, this might damage the device!
		Power on and DC bus voltage available ("Ab")	
	Flashing yellow	Warning	Read exact status via "S-0-0095, Diagnostic message" and carry out service function
	Yellow	Firmware update running	During the firmware update, do not interrupt the 24V supply and do not unplug connectors
	Flashing red	Errors	Read exact status via "S-0-0095, Diagnostic message" and carry out service function
	Red	Booting phase	Wait until booting phase is over (approx. 2 minutes)
		System error	Switch off and on; replace hardware, if necessary

Fig. 13-3: LED Displays KSM/KMS (up to MPB-07V10)

13.2 Electronic Control System KCU

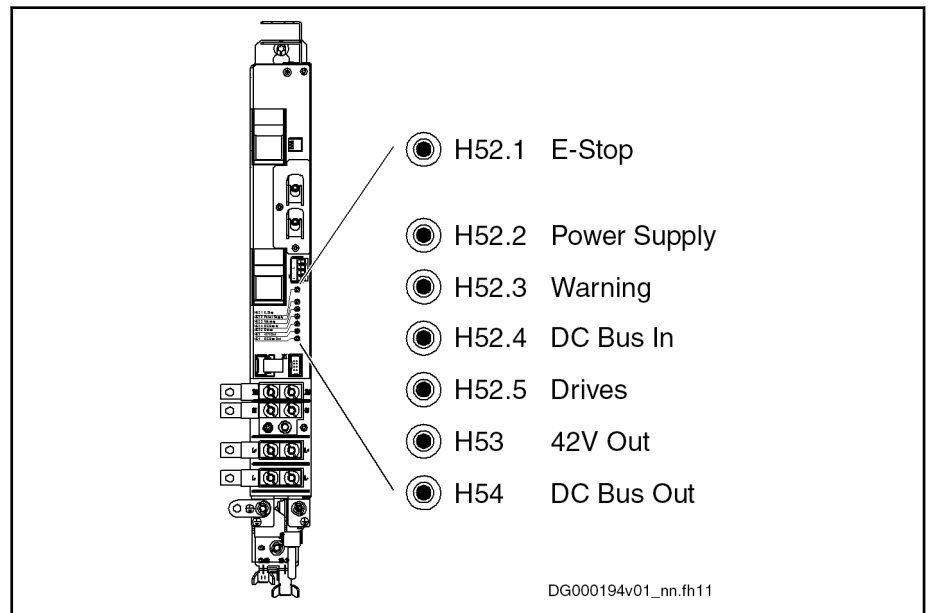

Fig. 13-4: LEDs at KCU

LED	Color / status		Significance	Measures
H52.1 E-Stop	○	Off	E-Stop not activated	Deactivate E-Stop, if necessary
	☠	Red	E-Stop active (/E_Stop)	Activate E-Stop, if necessary (see connection point X50)
H52.2 Power Supply	☀	Green	Supply unit without error, regular status	None
	☠	Red	Supply unit signals error (/Bb_V)	<ul style="list-style-type: none"> • Check power supply, see also "F2086 Error supply module" • Check whether terminal connector RHS is missing at X3.1 or X3.2 at last KSM of a string of drives
H52.3 Warning	☀	Green	Supply unit without warning (/Warn), regular status	None
	☠	Red	Supply unit signals warning	Check supply unit, see also "E2086 Pre-warning supply module overload"
H52.4 DC Bus In	○	Off	DC bus voltage (L+; L-) too low	Switch power on at supply unit
	☀	Green	DC bus voltage (L+; L-) without error (Ud), regular status	None

Rexroth IndraDrive Mi Diagnostic Display









LED	Color / status		Significance	Measures
H52.5 Drives		Green	No error at module bus, regular status	None
		Red	Module bus error (/Bb_A)	<ul style="list-style-type: none"> • Check module bus wiring • Check control voltage supply of the devices; see also "F2087 Module group communication error"
		Red/ green flashing	Drive system carries out error reaction (Bb_A)	Bring device at module bus to readiness for operation; see also diagnostic message "E2810 Drive system not ready for operation"
H53 42V Out		Green	Control voltage for KSM at output X53 okay	None
		Red	Control voltage for KSM at output X53 faulty	Overload at output: <ul style="list-style-type: none"> • Check voltage at X53 • Reduce load • Remove short circuit
H54 DC Bus Out		Off	DC bus (L+, L-) not ready for power output	Voltage at X54 is only monitored, if DC bus voltage at input (L+, L-) without error (see LED H52.4)
		Green	DC bus voltage (L+; L-) at output X54 okay (U > 50 V)	None
		Red	DC bus voltage (L+; L-) at output X54 not okay	Check fuses F4, F5 and replace them, if necessary

Fig. 13-5: LED Displays KCU

14 Handling, Diagnostic and Service Functions

14.1 Firmware Replacement

See Functional Description of firmware "Firmware Replacement".

14.2 Firmware Download

The firmware download is carried out with the auxiliary program "Loader". The loader is either

- activated via the valid firmware available in the device, if the firmware is to be updated,
- or -
- activated directly via the control section if there isn't any valid firmware available in the device.

The list below contains the causes of invalid firmware in the device:

Cause	Remedy
Firmware download via IndraWorks aborted (e.g., computer crash or cable removed during download) - or - Firmware replacement via MMC aborted (MMC was removed) - or - Voltage failure during firmware replacement	Firmware must be reloaded via serial connection (IndraWorks) (see Functional Description "Firmware Replacement")
Device-internal, non-volatile flash memory defective	Replace drive controller

14.3 Messages During Firmware Download

The active loader appears on the display. It precedes the download status display:

- **FL: ??????**: The loader of the firmware is active
- **LD: ??????**: The loader of the control section is active



Explanation of the messages displayed during firmware download:

XX: ?????? = active loader : download status

During error-free firmware download, the following diagnostic messages are displayed:

- XX: DL
- XX: ERASE
- XX: PROG
- XX: CKS

14.4 FL: DL

Brief Description: Download -> Shutdown carried out successfully
 A shutdown was carried out.

Handling, Diagnostic and Service Functions

FL: DL: The firmware loader is active.

LD: DL: The loader in the control section is active.



You can only exit the shutdown mode by rebooting (requested via the master communication or by switching the drive off).

14.5 FL:ERASE

Brief Description: Clearing active

The loader (**FL:ERASE** = firmware loader, **LD:ERASE** = loader in control section) is in the clearing mode. The requested memory range / module is being cleared.

14.6 FL: PROG

Brief Description: Programming active

The loader (**FL:PROG** = firmware loader, **LD:PROG** = loader in control section) is in the programming mode. The transmitted data are written to the requested address in the memory range / module.

14.7 FL: CKS

Brief Description: Checksum calculation active

The checksum calculation is active. Subsequent to the calculation a comparison with the stored checksums is run.



"**FL: CKS**" means firmware loader and "**LD: CKS**" means loader in control section.

14.8 FL:E ADR

Brief Description: Warning: Address error

Cause	Remedy
Address read from IBF file is outside of allowed range	Please contact our service department



"**FL:E ADR**" means firmware loader and "**LD:E ADR**" means loader in control section.

14.9 FL:E SEC

Brief Description: Warning: Range error

Cause	Remedy
Data in IBF concerning memory range (firmware, loader, boot kernel) are incorrect	Please contact our service department



"**FL: SEC**" means firmware loader and "**LD: SEC**" means loader in control section.

14.10 FL:E FW

Brief Description: Warning: No valid firmware available

Handling, Diagnostic and Service Functions

Cause	Remedy
Firmware module contained in internal memory is defective, therefore clearing of loader is impossible	Update firmware (using "IndraWorks" or by starting command "P-0-4072, C2900 Command Firmware update from MMC")



"FL:E FW" means firmware loader and "LD:E FW" means loader in the control section.

14.11 FL:E LD

Brief Description: Warning: No valid loader available

Cause	Remedy
Loader contained in internal memory is defective, therefore deleting of firmware is impossible	Update firmware (using "IndraWorks" or by starting command "P-0-4072, C2900 Command Firmware update from MMC")



"FL:E LD" means firmware loader and "LD:E LD" means loader in the control section.

14.12 FL:E SEQ

Brief Description: Warning: Sequence error

Cause	Remedy
Command order was not complied with when drive firmware was programmed	Use "IndraWorks" or command "P-0-4072, C2900 Command Firmware update from MMC" to update firmware - or - Carry out shutdown before clearing or programming drive firmware
Attempt was made to write to range with valid checksum	Delete range to which data is to be written before writing



"FL:E SEQ" means firmware loader and "LD:E SEQ" means loader in the control section.

14.13 FL:F9002

Brief Description: Error: Operating system error
 See "F9002 Error internal RTOS function call"

14.14 FL:F2100

Brief Description: Error: Internal memory defective
 See "F2100 Incorrect access to command value memory"

14.15 FL:F CKS

Brief Description: Error: Checksum error

Handling, Diagnostic and Service Functions

Cause	Remedy
Checksums of programmed modules are calculated after firmware update. Calculated and entered checksums were detected to be different	Carry out firmware update again; should error occur again, please contact our service department



"FL:F CKS" means firmware loader and "LD:F CKS" means loader in control section.

14.16 FL:F ACC

Brief Description: Error: Access error

Cause	Remedy
Several possibilities of firmware update (serial and MMC) were used simultaneously . An access conflict has occurred	Restart firmware update using only one possibility (serial or MMC)



"FL:F ACC" means firmware loader and "LD:F ACC" means loader in control section.

14.17 FL:F2101

Brief Description: Error: MMC defective

See "F2101 It was impossible to address MMC"

14.18 FL:F8122

Brief Description: Error: Control section defective

An error occurred during firmware update.

Cause	Remedy
Hardware of control section is defective	Replace control section or entire drive controller; use hardware configuration of same type



Only Rexroth service engineers or especially trained users are allowed to replace the control section. The replacement of the entire drive controller is described in the Project Planning Manual for the power section.

Identical cause / remedy: "F8122 Control section defective"

14.19 FL:F8129

Brief Description: Error: Optional module incorrectly programmed

See "F8129 Incorrect optional module firmware"

14.20 FL:F8130

Brief Description: Error: optional safety module 2 incorrectly programmed

See "F8130 Firmware of option 2 of safety technology defective"

14.21 FL:F8120

Brief Description: Error: Firmware does not support hardware
See "F8120 Invalid control section/firmware combination"

15 Notes for Machine Operators

15.1 General Information

Time-consuming debugging attempts and repair of drive components at the machine cannot be accepted due to the production downtimes this implies.

The modularity of the Rexroth AC drives allows replacing individual drive components. In case servicing becomes necessary, you can confine yourself to locating errors at the motor, at the drive controller or at the supply unit and to replacing the respective component.



Repeated adjustments are not required.

15.2 Diagnosing Malfunction and Removing Errors

Diagnosing Malfunction The supply unit signals operating states, warnings or errors via the display at the front of the device.

Prerequisites for diagnosing failures are that the control voltage +24 V is within tolerance and the processors in the supply unit and the drive controllers are working without error.

Resetting an Error Stored error messages have to be reset before the device is ready for operation again. An error can be reset by

- Pressing the <ESC> key at the control panel for starting the RESET command (cf. "S-0-0099, C0500 Reset class 1 diagnostics") or
- Switching off the control voltage supply or
- RESET command via the module bus (by drive)

NOTICE

Destruction of the supply unit when power is switched on and a drive controller is defective!

⇒ After having reset an overcurrent error and after having replaced a defective supply unit, the error memories of the drive controllers have to be read before the supply unit is switched on again.

Before switching power on, remove any possible short circuit in the DC bus!

Replacing Defective Drive Components

If a defective component must be replaced, the following aspects have to be observed:

- Only Rexroth service engineers or especially trained users are allowed to replace the control section. The replacement of the entire drive controller is described in the Project Planning Manual for the power section.
- Only Rexroth service engineers are allowed to replace options of the control section.
- The replacement of the supply unit is described in the Project Planning Manual for the supply unit.
- In case devices fail within the warranty period, the defective components must be returned to Bosch Rexroth; for addresses and telephone numbers, please see the printed documentation (chapter "Service and Support") or the Internet (<http://www.boschrexroth.com>).

Checks and Repairs If checks or repairs are required, the following aspects apply:

Notes for Machine Operators

- Checks and repairs may only be carried out by the Rexroth service department or by especially trained staff.
- For checks at the installation, the corresponding safety regulations must be complied with.
- Repair of drive components at the machine can be very time-consuming. For this reason, replace defective drive components completely.

⚠ WARNING

Danger to persons and damage to machines can arise from the removal of malfunction!

- ⇒ Only have malfunction removed by especially trained staff.
- ⇒ Do not put protective devices out of operation.
- ⇒ Observe the Safety Instructions for Electric Drives and Controls in the homonymous chapter.

15.3 Contacting the Service Department

If you would like to contact our service department, we ask you to have the following information ready in order to facilitate quick and purposeful handling:

- Type data and serial numbers of devices and motors
- Failure condition
- Diagnostic displays, if available
- Drive firmware used

For addresses and telephone numbers, please see the printed documentation (chapter "Service and Support") or the Internet (<http://www.boschrexroth.com>).

16 Notes for Installation Programmers

16.1 How to Handle Command Errors

If an error occurs during the execution of a command, the respective command error is generated by the drive.

There are several possibilities of diagnosing a command error:

- Evaluate the command change bit in "P-0-0115, Device control: Status word"
- Evaluate "S-0-0390, Diagnostic message number" which contains the error message as a number (e.g. C0201)
- Evaluate "S-0-0095, Diagnostic message" which contains the error message as ASCII text (e.g. "C0201 Invalid parameters (->S-0-0423)")
- Evaluate the command status (see Functional Description "Command Processing")



A command error cannot be removed by "clearing errors", but only by completing the corresponding command.

Notes for Installation Programmers

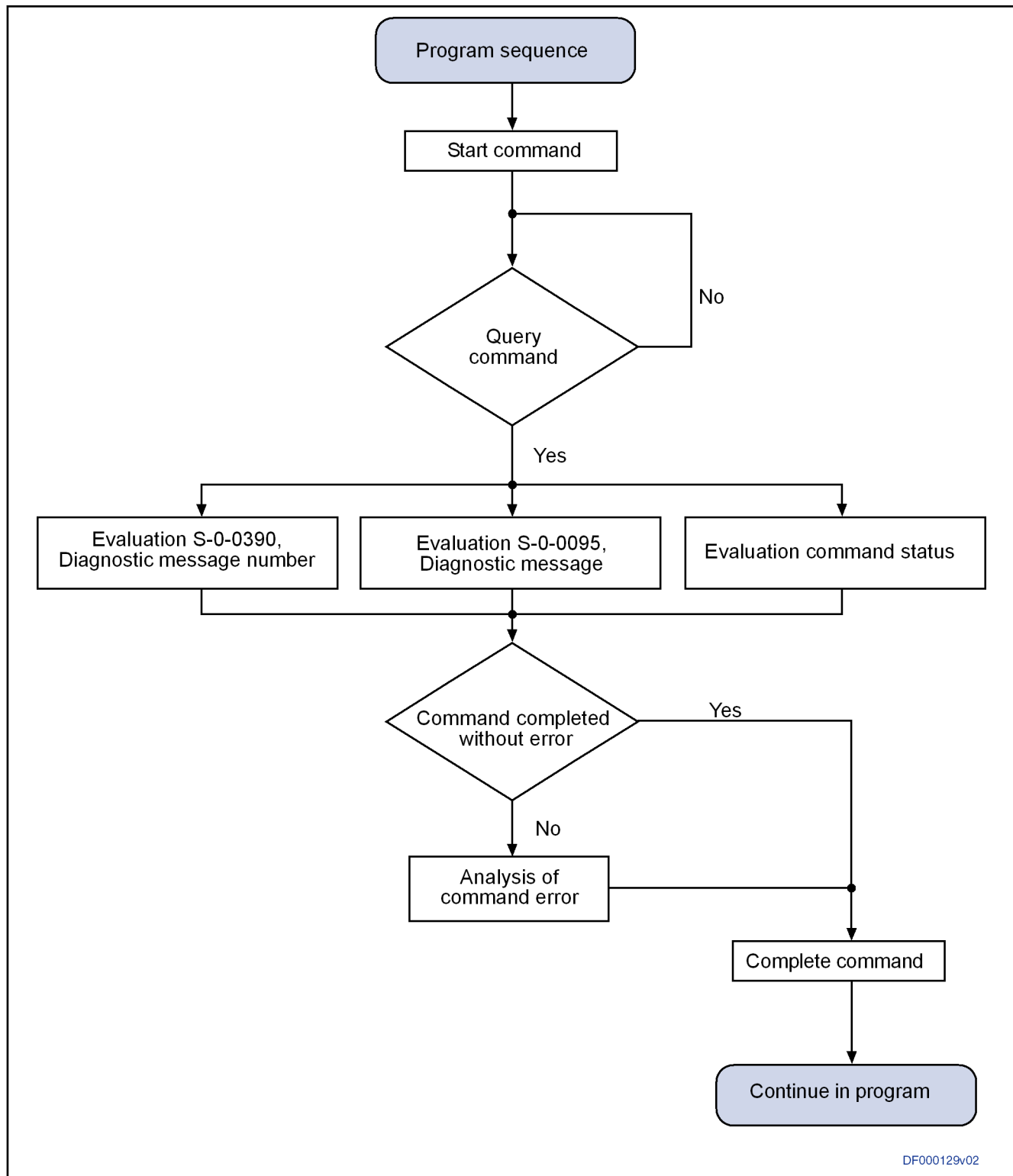

Fig. 16-1: Example of Command Handling

16.2 How to Handle Errors

If an error occurs while the drive is in operation, the corresponding error reaction is carried out.

There are several possibilities of diagnosing a drive error:

- Evaluate the collective error bit (class 1 diagnostics bit) in the respective master communication status word (e.g. "S-0-0135, Drive status word"; "P-0-4078, Field bus: Status word")
- Evaluate "S-0-0011, Class 1 diagnostics" in order to obtain the detailed information with regard to the cause of the error
- Evaluate "S-0-0390, Diagnostic message number" which contains the error message as a number (e.g. F6034)
- Evaluate "S-0-0095, Diagnostic message" which contains the error message as ASCII text (e.g. "F6034 Emergency-Stop")



Before a drive error is cleared, the cause for the occurrence of the error should be investigated and permanently removed.

Notes for Installation Programmers

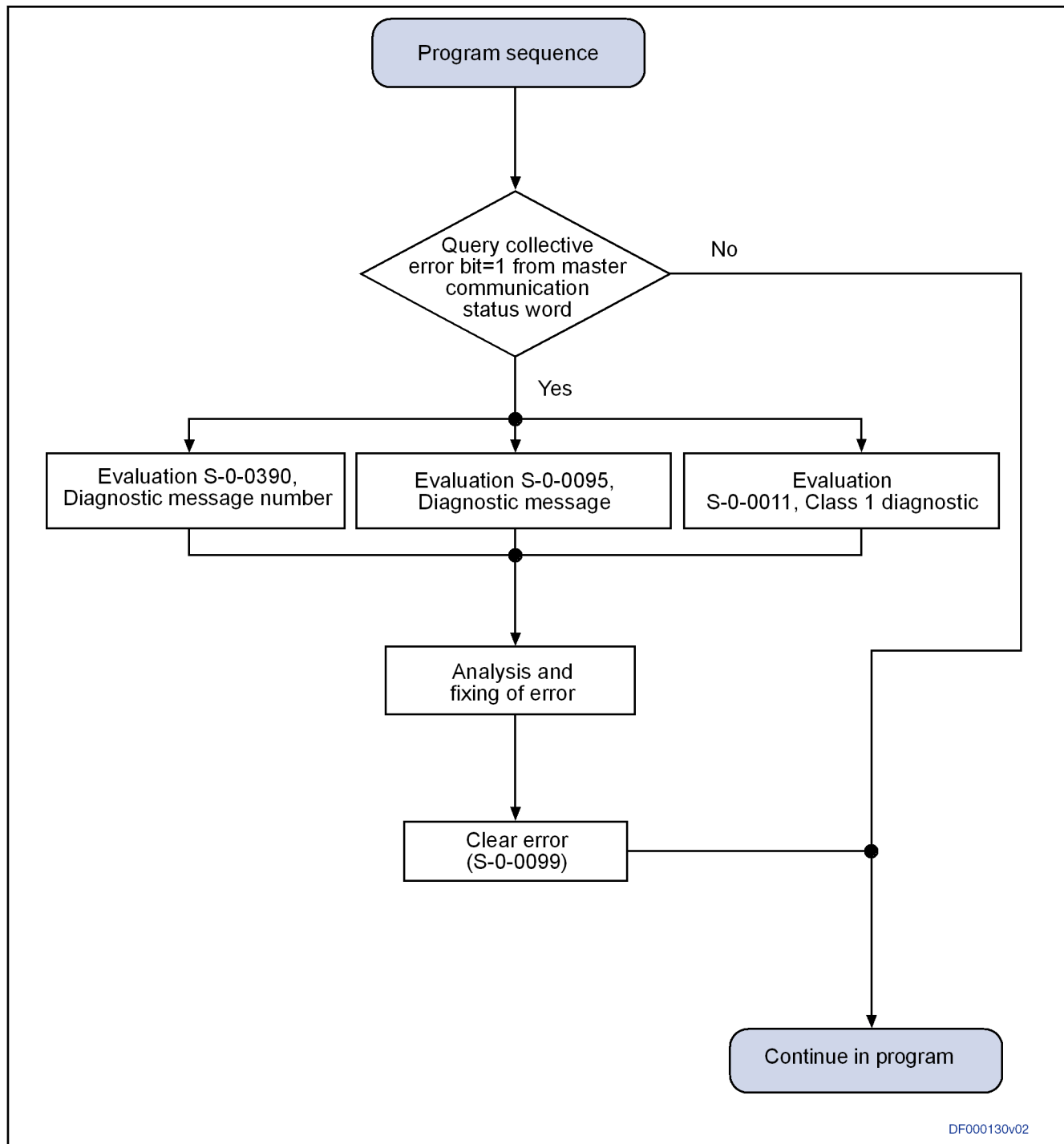

DF000130v02

Fig. 16-2: Example of Error Handling

16.3 How to Handle Warnings

If a warning occurs while the drive is in operation, this diagnostic warning message is maintained as long as the condition for the warning has been fulfilled.

There are several possibilities of diagnosing a drive warning:

- Evaluate the collective warning bit (class 2 diagnostics bit) in the respective master communication status word (e.g. "S-0-0135, Drive status word"; "P-0-4078, Field bus: Status word")
- Evaluate "S-0-0012, Class 2 diagnostics" in order to obtain the detailed information with regard to the cause of the warning
- Evaluate "S-0-0390, Diagnostic message number" which contains the warning message as a number (e.g. E2054)
- Evaluate "S-0-0095, Diagnostic message" which contains the warning message as ASCII text (e.g. "E2054 Not homed")



Warnings cannot be cleared. They persist until the condition that activated the warning is no longer fulfilled. In order to remove the cause of the triggering of the warning, carry out the remedy specified in the description of the respective warning.

Notes for Installation Programmers

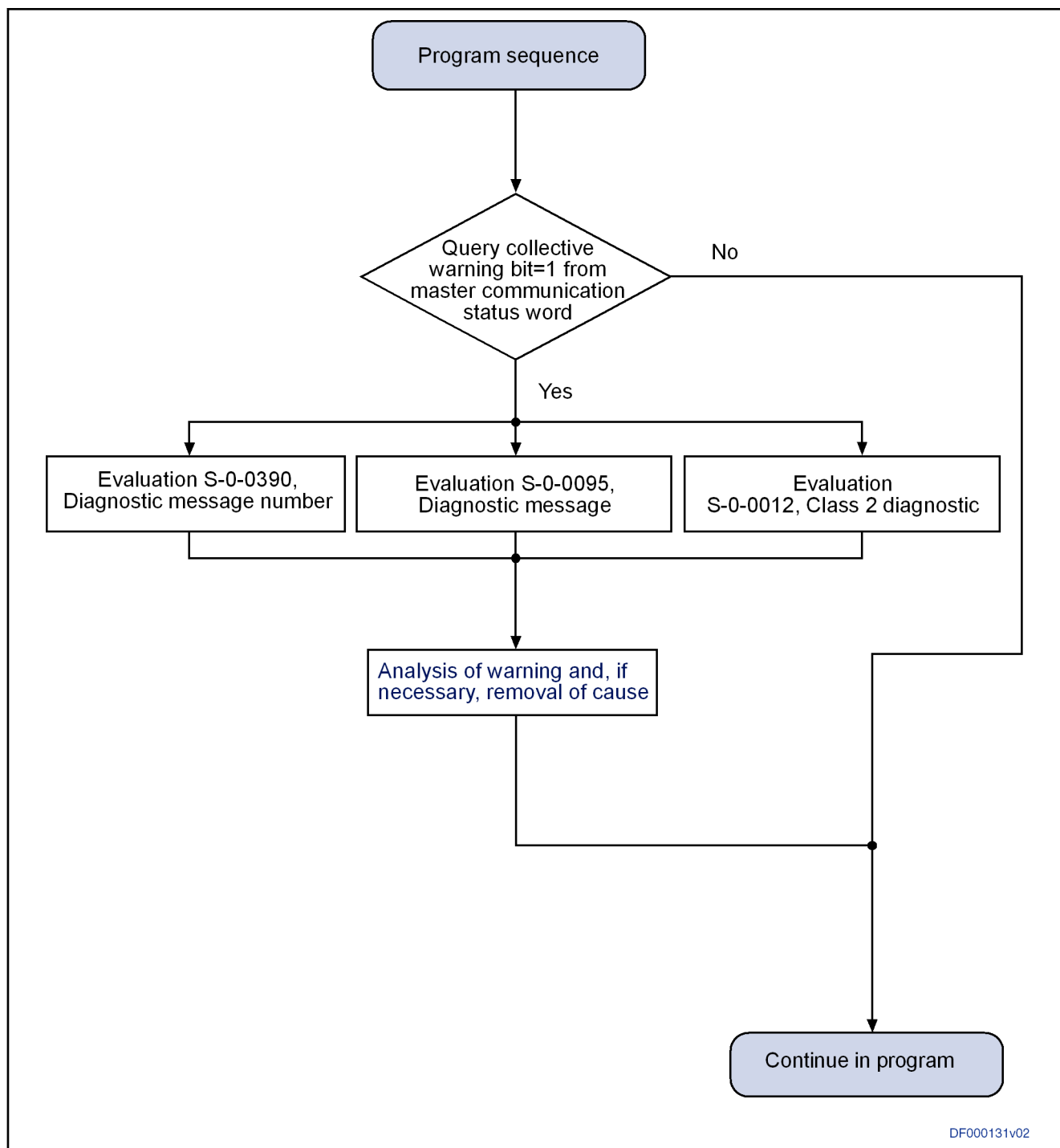

Fig. 16-3: Example of Warning Handling



For drives with SERCOS master communication, it is only possible to reset the collective warning bit (change bit of class 2 diagnostics) by read-accessing the parameter "S-0-0012, Class 2 diagnostics".

17 Service and Support

Our worldwide service network provides an optimized and efficient support. Our experts offer you advice and assistance should you have any queries. You can contact us **24/7**.

Service Germany Our technology-oriented Competence Center in Lohr, Germany, is responsible for all your service-related queries for electric drive and controls.

Contact the **Service Helpdesk & Hotline** under:

Phone:	+49 9352 40 5060
Fax:	+49 9352 18 4941
E-mail:	service.svc@boschrexroth.de
Internet:	http://www.boschrexroth.com

Additional information on service, repair (e.g. delivery addresses) and training can be found on our internet sites.

Service worldwide Outside Germany, please contact your local service office first. For hotline numbers, refer to the sales office addresses on the internet.

Preparing information To be able to help you more quickly and efficiently, please have the following information ready:

- Detailed description of malfunction and circumstances resulting in the malfunction
- Type plate name of the affected products, in particular type codes and serial numbers
- Your contact data (phone and fax number as well as your email address)

Index

A

A0000 Communication phase 0.....	87
A0001 Communication phase 1.....	87
A0002 Communication phase 2.....	88
A0003 Communication phase 3.....	89
A0009 Automatic baud rate detection for SERCOS interface.....	89
A0010 Drive HALT.....	90
A0011 Safe torque off active.....	90
A0012 Control and power sections ready for operation.....	91
A0013 Ready for power on.....	91
A0014 Safe stop 1 (Emergency stop) active.....	92
A0015 Safe stop 1 active.....	93
A0016 Safe stop 2 active.....	93
A0017 Special mode motion active.....	94
A0018 Special mode safe motion 1 active.....	95
A0019 Special mode safe motion 2 active.....	96
A0020 Special mode safe motion 3 active.....	97
A0021 Special mode safe motion 4 active.....	99
A0050 Parameterization level 1 active.....	100
A0051 Operating mode.....	100
A0100 Torque control.....	100
A0101 Velocity control.....	101
A0102 Position mode, encoder 1.....	101
A0103 Position mode, encoder 2.....	101
A0104 Position mode lagless, encoder 1.....	102
A0105 Position mode lagless, encoder 2.....	102
A0106 Drive-internal interpolation, encoder 1...	103
A0107 Drive-internal interpolation, encoder 2...	103
A0108 Drive controlled interpolation, lagless, encoder 1.....	103
A0109 Drive controlled interpolation, lagless, encoder 2.....	104
A0110 Velocity synchronization, virtual mas- ter axis.....	104
A0111 Velocity synchronization, real master axis.....	105
A0112 Phase synchronization, encoder 1, virtual master axis.....	105
A0113 Phase synchronization, encoder 2, virtual master axis.....	105
A0114 Phase synchronization, encoder 1, real master axis.....	106
A0115 Phase synchronization, encoder 2, real master axis.....	106
A0116 Phase synchr. lagless, encoder 1, virtual master axis.....	107
A0117 Phase synchr. lagless, encoder 2, virtual master axis.....	107
A0118 Phase synchr. lagless, encoder 1, re- al master axis.....	107
A0119 Phase synchr. lagless, encoder 2, re- al master axis.....	108
A0128 Cam, encoder 1, virtual master axis.....	108

A

A0129 Cam, encoder 2, virtual master axis.....	109
A0130 Cam, encoder 1, real master axis.....	109
A0131 Cam, encoder 2, real master axis.....	109
A0132 Cam, lagless, encoder 1, virt. master axis.....	110
A0133 Cam, lagless, encoder 2, virt. master axis.....	110
A0134 Cam, lagless, encoder 1, real master axis.....	111
A0135 Cam, lagless, encoder 2, real master axis.....	111
A0136 MotionProfile, encoder 1, virtual mas- ter axis.....	112
A0137 MotionProfile, encoder 2, virtual mas- ter axis.....	112
A0138 MotionProfile, encoder 2, real master axis.....	113
A0139 MotionProfile, encoder 1, real master axis.....	113
A0140 MotionProfile lagless, encoder 1, vir- tual master axis.....	114
A0141 MotionProfile lagless, encoder 2, vir- tual master axis.....	114
A0142 MotionProfile lagless, encoder 1, real master axis.....	115
A0143 MotionProfile lagless, encoder 2, real master axis.....	115
A0150 Drive-controlled positioning, encoder 1.	116
A0151 Drive-controlled positioning, encoder 1, lagless.....	116
A0152 Drive-controlled positioning, encoder 2.	117
A0153 Drive-controlled positioning, encoder 2, lagless.....	117
A0154 Position mode drive controlled, en- coder 1.....	118
A0155 Position mode drive controlled, en- coder 2.....	118
A0156 Position mode lagless, encoder 1 drive controlled.....	119
A0157 Position mode lagless, encoder 2 drive controlled.....	119
A0160 Position mode drive controlled.....	120
A0161 Drive-controlled positioning.....	120
A0162 Positioning block mode.....	121
A0163 Position synchronization.....	121
A0164 Velocity synchronization.....	122
A0206 Positioning block mode, encoder 1.....	122
A0207 Positioning block mode lagless, en- coder 1.....	122
A0210 Positioning block mode, encoder 2.....	123
A0211 Positioning block mode lagless, en- coder 2.....	123
A0403 Quick stop with probe detection is ac- tive.....	123

Index

A

A0500 Supply module in voltage control.....	124
A0502 Supply module in operation.....	124
A0503 DC bus charging active.....	124
A0520 DC bus quick discharge active.....	125
A0800 Unknown operating mode.....	125
A4000 Automatic drive check and adjustment..	126
A4001 Drive deceleration to standstill.....	126
A4002 Drive in automatic mode.....	127
A4003 Setting-up mode is active.....	127
Ab.....	75
AC.....	75
ActLW Up	83
Administration commands.....	71
AE.....	75
AF.....	75
AH.....	75
Appropriate use.....	27
Applications	27
AR.....	75
AS.....	75
ASP.....	75
AU.....	75

B

bb.....	75
---------	----

C

C0100 Communication phase 3 transition check.....	341
C0101 Invalid parameters (-> S-0-0021).....	368
C0102 Limit error in parameter (-> S-0-0021)...	368
C0103 Parameter conversion error (->S-0-0021).....	369
C0104 Config. IDN for MDT not configurable... 369	
C0105 Maximum length for MDT exceeded.....	370
C0106 Config. IDNs for AT not configurable.....	370
C0107 Maximum length for AT exceeded.....	371
C0108 Time slot parameter > Sercos cycle time.....	371
C0109 Telegram offset unsuitable.....	372
C0110 Length of MDT (S-0-0010) odd.....	373
C0111 ID9 + Record length - 1 > length MDT (S-0-0010).....	374
C0112 TNcyc (S-0-0001) or TScyc (S-0-0002) error.....	374
C0113 Relation TNcyc (S-0-0001) to TScyc (S-0-0002) error.....	375
C0114 T4 > TScyc (S-0-0002) - T4min (S-0-0005).....	375
C0115 T2 too small.....	376
C0116 T3 (S-0-0008) within MDT (S-0-0089 + S-0-0010).....	376
C0118 Order of cyclic command value configuration incorrect.....	377
C0119 Max. travel range too large.....	377

C

C0120 Error when reading encoder data => motor encoder.....	378
C0121 Incorrect parameterization of motor encoder (hardware).....	378
C0122 Incorr. parameteriz. of motor enc. (mechanical system).....	379
C0123 Modulo value for motor encoder cannot be displayed.....	379
C0124 Motor encoder unknown.....	380
C0125 Error when reading encoder data => optional encoder.....	381
C0126 Incorrect parameterization of optional enc. (hardware).....	381
C0127 Incorr. parameteriz. of opt. enc. (mechanical system).....	382
C0128 Modulo value for optional encoder cannot be displayed.....	382
C0129 Optional encoder unknown.....	383
C0130 Maximum travel range cannot be displayed internally.....	383
C0131 Switching to phase 3 impossible.....	384
C0132 Invalid settings for controller cycle times.....	384
C0134 Invalid motor data in encoder memory (->S-0-0021).....	385
C0135 Type of construction of motor P-0-4014 incorrect.....	386
C0136 Several motor encoders connected.....	386
C0137 Error during initialization of motor data (->S-0-0021).....	387
C0138 Invalid control section data (->S-0-0021).....	387
C0139 T2 (S-0-0089)+length MDT (S-0-0010)>TScyc (S-0-0002).....	388
C0140 Rotary scaling not allowed.....	388
C0151 IDN for command value data container not allowed.....	389
C0152 IDN for actual value data container not allowed.....	389
C0153 Error at init. of synchr. motor with reluctance torque.....	390
C0154 Field bus: IDN for cycl. command val. not configurable.....	390
C0155 Field bus: Max. length for cycl. command val. exceeded.....	391
C0156 Field bus: IDN for cycl. actual val. not configurable.....	391
C0157 Field bus: Length for cycl. actual values exceeded.....	392
C0158 Field bus: Tcyc (P-0-4076) incorrect....	392
C0159 Field bus: P-0-4077 missing for cycl. command values.....	393
C0160 Error when reading encoder data => measuring encoder.....	393
C0161 Incorr. parameterization of measuring enc. (hardware).....	394

C

C0162 Measuring encoder unknown..... 394
 C0163 Modulo value for measuring encoder cannot be displayed..... 395
 C0164 Incorrect measuring encoder configuration..... 395
 C0170 Config. IDNs for connection not configurable..... 396
 C0171 Maximum length for connections exceeded..... 396
 C0172 Delay measurement (S-0-1024) not carried out..... 397
 C0173 Connections (number) not configurable 397
 C0174 Connection configuration not allowed... 397
 C0175 Producer cycle time of a connection not correct..... 398
 C0199 Functional package selection changed. Restart..... 398
 C0200 Exit parameterization level procedure command..... 341
 C0201 Invalid parameters (->S-0-0423)..... 399
 C0202 Parameter limit error (->S-0-0423)..... 399
 C0203 Parameter conversion error (->S-0-0423)..... 400
 C0210 Feedback 2 required (->S-0-0423)..... 401
 C0212 Invalid control section data (->S-0-0423)..... 401
 C0218 Double signal selection master axis format converter..... 402
 C0219 Max. travel range too large..... 402
 C0220 Error when initializing position of encoder 1..... 403
 C0221 Initialization velocity encoder 1 too high 404
 C0223 Invalid settings for controller cycle times..... 404
 C0224 Error when initializing position of encoder 2..... 404
 C0225 Initialization velocity encoder 2 too high 405
 C0227 Error when initializing position of measuring encoder..... 405
 C0228 Initialization velocity measuring encoder too high..... 406
 C0229 Field bus: IDN for cycl. command val. not configurable..... 407
 C0230 Field bus: Max. length for cycl. command val. exceeded..... 407
 C0231 Field bus: IDN for cycl. actual val. not configurable..... 407
 C0232 Field bus: Length for cycl. actual values exceeded..... 408
 C0233 Field bus: Tcyc (P-0-4076) incorrect.... 408
 C0234 Field bus: P-0-4077 missing for cycl. command values..... 409
 C0238 Order of cyclic command value configuration incorrect..... 409
 C0239 IDN for command value data container not allowed..... 410

C

C0240 IDN for actual value data container not allowed..... 410
 C0241 Incorrect parameterization of motion task..... 411
 C0242 Multiple configuration of a parameter (->S-0-0423)..... 411
 C0243 Brake check function not possible..... 413
 C0244 Act. modulo value cycle greater than max. travel range..... 414
 C0245 Operation mode configuration (->S-0-0423) not allowed..... 415
 C0246 Trav. range lim. switch not ass. to dig. input..... 416
 C0247 Dig. output already assigned to other axis..... 417
 C0248 Dig. input assigned differently to axes... 417
 C0249 Dig. I/Os: Bit number too large..... 418
 C0250 Probe inputs incorrectly configured..... 418
 C0251 Error during synchronization to master communication..... 419
 C0252 Incorrect MLD initialization (write access->S-0-0423)..... 419
 C0253 Error in combination operation mode - encoder (->S-0-0423)..... 420
 C0254 Configuration error PROFIsafe..... 420
 C0255 Safety command for system init. incorrect..... 421
 C0256 Safety technology configuration error... 421
 C0257 Error in safety technology encoder initialization..... 422
 C0258 Error in relation TNcyc (S-0-0001) to fine interpol..... 423
 C0259 MLD configuration error (->S-0-0423)... 423
 C0260 Incremental enc. emulator resol. cannot be displayed..... 424
 C0261 Emulator (P-0-0902) activated for both axes..... 425
 C0265 Incorrect CCD address configuration... 425
 C0266 Incorrect CCD phase switch..... 426
 C0267 CCD timeout phase switch..... 426
 C0270 Error when reading encoder data => motor encoder..... 427
 C0271 Incorrect parameterization of motor encoder (hardware)..... 428
 C0272 Incorr. parameteriz. of motor enc. (mechanical system)..... 428
 C0273 Modulo value for motor encoder cannot be displayed..... 429
 C0274 Motor encoder unknown..... 429
 C0275 Error when reading encoder data => optional encoder..... 430
 C0276 Incorrect parameterization of optional enc. (hardware)..... 430
 C0277 Incorr. parameteriz. of opt. enc. (mechanical system)..... 431

Index

C

C0278 Modulo value for optional encoder cannot be displayed.....	431
C0279 Optional encoder unknown.....	432
C0280 Maximum travel range cannot be displayed internally.....	433
C0281 Commutation via encoder-2 impossible	433
C0282 Sensorless posit. of synchr. motors, invalid ctrl parameters.....	434
C0283 Error during initialization of motor control (->S-0-0423).....	434
C0284 Invalid motor data in encoder memory (->S-0-0423).....	435
C0285 Type of construction of motor P-0-4014 incorrect.....	436
C0286 Several motor encoders connected.....	437
C0287 Error during initialization of motor data (->S-0-0423).....	437
C0288 Rotary scaling not allowed.....	439
C0289 Error at init. of synchr. motor with reluctance torque.....	439
C0290 Error when reading encoder data => measuring encoder.....	440
C0291 Incorr. parameterization of measuring enc. (hardware).....	441
C0292 Measuring encoder unknown.....	442
C0293 Modulo value for measuring encoder cannot be displayed.....	442
C0294 Incorrect measuring encoder configuration.....	443
C0298 Impossible to exit parameterization level.....	443
C0299 Configuration changed. Restart.....	444
C0300 Set absolute position procedure command.....	341
C0301 Measuring system unavailable.....	444
C0302 Absolute evaluation of measuring system impossible.....	445
C0303 Absolute encoder offset cannot be saved.....	445
C0400 Activate parameterization level 1 procedure command.....	342
C0401 Switching not allowed.....	446
C0403 Switching to CCD phase 2 impossible. .	446
C0500 Reset class 1 diagnostics, error reset. .	342
C0501 Error clearing only in parameter mode. .	447
C0600 Drive-controlled homing procedure command.....	342
C0601 Homing only possible with drive enable	447
C0602 Distance home switch - reference mark erroneous.....	448
C0603 Homing impossible with optional encoder.....	448
C0604 Homing impossible with absolute encoder.....	449
C0606 Reference mark not detected.....	449
C0607 Reference cam input not assigned.....	450

C

C0608 Pos. stop a. HW lim. switch not allowed f. modulo axes.....	450
C0609 Different travel directions parameterized.....	450
C0610 Absolute encoder offset could not be saved.....	451
C0700 Load defaults proced. command (motor-spec. controller val.).....	343
C0702 Default parameters not available.....	451
C0703 Default parameters invalid.....	452
C0704 Parameters not copyable.....	452
C0706 Error when reading the controller parameters.....	453
C0720 Load defaults procedure command (safety technology).....	344
C0722 Parameter default value incorrect (-> S-0-0423).....	453
C0723 Safety command for load defaults procedure incorrect.....	454
C0724 Timeout of safety command for load defaults procedure.....	454
C0730 Load defaults procedure command (MLD).....	345
C0740 Command Activate field bus profile settings.....	345
C0750 Load defaults procedure command (factory settings).....	346
C0751 Parameter default value incorrect (-> S-0-0423).....	455
C0752 Locked with password.....	456
C0799 An invalid index was set.....	456
C0800 Load basic parameters command.....	346
C0851 Parameter default value incorrect (-> S-0-0021).....	457
C0852 Locked with password.....	457
C0900 Position spindle command.....	347
C0902 Spindle positioning requires drive enable.....	457
C0903 Error during initialization.....	458
C0906 Error during search for zero pulse.....	458
C1200 Commutation offset setting command... .	347
C1204 Error in offset calculation.....	459
C1208 No adjustment with asynchronous motor.....	459
C1209 Proceed to phase 4.....	459
C1211 Commutation offset could not be determined.....	460
C1212 Motion range exceeded during commutation.....	460
C1214 Command only possible with linear synchronous motor.....	461
C1215 Command only possible in 'bb'.....	461
C1216 Commutation determination not selected.....	462
C1217 Setting only possible in 'Ab'.....	462

C

C1218 Automatic commutation: Current too low..... 462
 C1219 Automatic commutation: Overcurrent... 463
 C1220 Automatic commutation: Timeout..... 464
 C1221 Automatic commutation: Iteration without result..... 464
 C1222 Error when writing offset parameters.... 465
 C1223 Command execution impossible..... 465
 C1300 Positive stop drive procedure command..... 347
 C1301 Class 1 diagnostics error at command start..... 466
 C1400 Command Get marker position..... 348
 C1402 Faulty reference mark signal..... 466
 C1500 Cancel reference point procedure command..... 348
 C1600 Parking axis command..... 348
 C1700 Command measuring wheel mode..... 349
 C1701 Measuring wheel mode not possible.... 466
 C1800 Command Drive optimization / command value box..... 349
 C1801 Start requires drive enable..... 467
 C1802 Motor feedback data not valid..... 467
 C1803 Inertia detection failed..... 468
 C1804 Automatic controller setting failed..... 469
 C1805 Travel range invalid..... 469
 C1806 Travel range exceeded..... 470
 C1807 Determining travel range only via travel distance..... 471
 C1808 Drive not homed..... 471
 C2000 Command Release motor holding brake..... 349
 C2001 Command not enabled..... 471
 C2100 Command Holding system check..... 350
 C2101 Holding system check only possible with drive enable..... 472
 C2103 Holding brake: Torque too low..... 472
 C2104 Command execution impossible..... 473
 C2105 Load of holding system greater than test torque..... 473
 C2106 Test torque of holding system not reached..... 474
 C2107 Redundant holding brake: Torque too low..... 477
 C2108 Error when releasing the holding system..... 477
 C2109 SBS: Test torque invalid..... 478
 C2200 Backup working memory procedure command..... 350
 C2202 Error when writing data to non-volatile memory..... 479
 C2300 Load working memory procedure command..... 350
 C2301 Error when reading non-volatile memory..... 479
 C2302 Error when converting parameters..... 479

C

C2400 Selectively backup working memory procedure command..... 351
 C2402 Error when saving parameters..... 480
 C2500 Copy IDN from optional memory to internal memory..... 351
 C2502 Error when accessing the MMC..... 480
 C2504 Error when writing data to internal memory..... 481
 C2600 Copy IDN from internal memory to optional memory..... 352
 C2602 Error when accessing the MMC..... 482
 C2604 Error when reading the internal memory..... 483
 C2800 Analog input adjustment command..... 352
 C2801 Analog input not configured..... 483
 C2802 Oscillations of input signal outside tolerance range..... 484
 C2803 Measured values at zero point and max. value identical..... 484
 C2804 Automatic adjustment failed..... 485
 C2900 Command Firmware update from MMC 353
 C2903 Error when accessing the MMC..... 485
 C2904 Error when accessing the flash..... 486
 C2905 Programmed firmware defective..... 486
 C3000 Synchronize and store safety technology IDN..... 353
 C3001 Synchronization and storage failed..... 487
 C3100 Recalculate actual value cycle..... 354
 C3101 Act. modulo value cycle greater than max. travel range..... 488
 C3102 Drive is still in drive enable..... 488
 C3200 Command Calculate motor data..... 354
 C3201 Incorrect input for current..... 488
 C3202 Incorrect input for voltage..... 489
 C3203 Incorrect input for frequency..... 489
 C3204 Incorrect input for speed..... 489
 C3205 Incorrect input for power factor..... 490
 C3206 Incorrect input for power..... 490
 C3207 Type plate list incomplete..... 491
 C3208 Error when writing parameters (->S-0-0423)..... 491
 C3209 Command execution impossible..... 491
 C3300 Set coordinate system procedure command..... 354
 C3400 Shift coordinate system procedure command..... 355
 C3500 Command Determine encoder correction values..... 355
 C3501 Acquisition velocity not allowed..... 492
 C3502 Motor encoder not available..... 492
 C3503 Optional encoder not available..... 493
 C3504 Measuring encoder not available..... 493
 C3505 No encoder selected..... 494
 C3506 Correction value table cannot be stored 494
 C3600 Command Motor data identification..... 355
 C3601 Motor not or not correctly connected.... 495

Index

C

C3602 Determined values invalid.....	495
C3603 Device current limit too low.....	496
C3604 Error when writing parameters (->S-0-0423).....	496
C3605 Motor turning.....	497
C3606 Type of construction of motor not allowed.....	497
C3607 Motor revolution/motion impeded.....	498
C3608 Incorrect motor phases or rotational direction of encoder.....	498
C3609 Incorrect number of pole pairs or number of encoder lines.....	499
C3610 No encoder: Validation check impossible.....	499
C3611 Test velocity not reached.....	500
C3700 Manually unlocking the safety door.....	356
C3701 Error when manually unlocking the safety door.....	500
C3800 Command Apply motor holding brake...	356
C3900 Command Holding brake resurfacing...	357
C3901 Resurfacing of holding brake only possible with drive enable.....	501
C3902 Error during resurfacing of holding brake.....	501
C3903 Command execution impossible.....	502
C4000 Homing procedure command channel 2.....	357
C4001 Error during safe homing procedure.....	502
C4002 Incorrect distance of dedicated point channel 1-2.....	503
C4100 Switch parameter set command.....	357
C4101 Switching only possible without AF.....	504
C4102 Switching only possible in parameter mode.....	504
C4103 Preselect parameter set forbidden value.....	505
C4104 Error during parameter set switching (->S-0-0423).....	505
C4200 Drive-controlled oscillation command...	357
C4201 Oscillation requires drive enable.....	505
C4202 Oscillation command speed cannot be reached.....	506
C4300 NC-controlled homing procedure command.....	358
C4302 Distance home switch - reference mark erroneous.....	506
C4304 Homing impossible with absolute encoder.....	507
C4306 Reference mark not detected.....	507
C4307 Reference cam input not assigned.....	508
C4308 Pos. stop a. HW lim. switch not allowed f. modulo axes.....	508
C4400 Calculate displacement procedure command.....	358
C4500 Displacement to referenced system procedure command.....	358

C

C4600 Command Calculate motor control parameters.....	359
C4601 Error when writing parameters (->S-0-0423).....	508
C4700 Command Activate easy startup mode.	359
C4701 Drive active, activation of easy startup impossible.....	509
C4800 Command Determine cogging torque compensation table.....	359
C4801 Cogging torque compensation: Measuring vel. too high.....	509
C4802 Cogging torque compensation: Measuring vel. too low.....	510
C4803 Cogging torque compensation: Inadmissible acceleration.....	510
C4804 Cogging torque comp.: Err. when storing corr. val table.....	511
C4805 Cogging torque comp.: Motor measuring system not homed.....	511
C4900 PLC command.....	360
C4901 PLC command error no. 1.....	512
C4902 PLC command error no. 2.....	512
C4903 PLC command error no. 3.....	512
C4904 PLC command error no. 4.....	513
C4910 PLC command timeout.....	513
C5200 Communication phase 4 transition check.....	360
C5300 SERCOS III: Command SYNC delay measurement.....	360
C5301 SERCOS III: Delay measurement failed.....	514
C5400 Command Save PLC retain data on MMC.....	361
C5401 PLC program not ready for retain data backup.....	514
C5402 Error when writing data to the MMC.....	515
C5500 Command Load PLC retain data from MMC.....	361
C5501 PLC program not ready for loading retain data.....	515
C5502 MMC not available or not OK.....	516
C5503 PLC retain data do not match PLC program.....	516
C5504 Unknown format in PLC retain file.....	517
C5505 Invalid PLC retain data.....	517
C5600 Command subsequent optimization of commutation offset.....	362
C5601 Command requires drive enable.....	518
C5602 Axis blocked.....	518
C5603 Timeout: Axis in motion.....	518
C5800 Command Apply redundant holding brake.....	362
C5801 Command Apply redundant holding brake not possible.....	519
C5900 Command Resurfacing of redundant holding brake.....	362

C

C5901 Comm. Resurfacing of red. holding brake only possible AF..... 519
 C5902 Error when resurfacing redundant holding brake..... 520
 C5903 Command execution impossible..... 520
 C6000 Set absolute position procedure command..... 363
 C6001 Measuring system unavailable..... 521
 C6002 Absolute evaluation of measuring system impossible..... 521
 C6003 Absolute encoder offset cannot be saved..... 522
 C6004 Command cannot be executed under drive enable..... 522
 C6100 Command Activate IP settings..... 363
 C6101 Incorrect IP settings..... 522
 C6200 Command Enabling SM without valid brake status..... 364
 C6201 Command execution impossible..... 523
 C6400 Reboot command..... 365
 C6401 reboot command impossible..... 524
 C6500 Save operating data on backup memory..... 365
 C6501 Error when writing backup data (backup memory)..... 524
 C6502 Error when reading backup data (device)..... 525
 C6503 Error when checking backup data (comparison)..... 526
 C6600 Restore operating data from backup memory..... 365
 C6601 Error when reading backup data (backup memory)..... 526
 C6602 Error when writing backup data (device)..... 527
 C6603 Error when writing comparative data (backup memory)..... 528
 C6604 Error when reading comparative data (device)..... 529
 C6605 Warning, restoration incomplete (device)..... 529
 C7000 CCD: Command adjust slave addresses..... 366
 C7001 CCD: Impossible to adjust slave addresses..... 530
 C7100 CCD: Command Close ring..... 366
 C7101 CCD: Impossible to close ring..... 531
 C7200 CCD: Command Apply I/O configuration..... 366
 C7201 CCD: Impossible to apply I/O configuration..... 531
 C7400 CCD: Switching to phase 2..... 367
 C7401 CCD: Impossible to switch to phase 2... 532
 C7500 CCD: Switching to phase 4..... 367
 C7501 CCD: Impossible to switch to phase 4... 532
 C7600 Command Create parameter image..... 367

C

C7601 Memory access impossible..... 533
 C7602 Slave access impossible..... 533
 Cables
 Documentation 25
 Cam shaft invalid..... 219
 charg..... 76
 Checksum of parameter values..... 70
 Clearing an error message..... 73
 CM..... 76
 Commands..... 71
 Commutation offset setting..... 347
 Components
 Documentations 24
 Control panel
 ... of the default control panel 50
 Control panels..... 49
 Control parameters..... 49

D

Data storage..... 69
 Definitions of terms, general basic principles..... 69
 Diagnosis..... 41
 Diagnostic display
 KCU (LED H52.1...H54) 587
 KSM/KMS (LED H14) 585
 Diagnostic message
 Diagnostic message in plain text 43
 Display 43
 Display text 44
 Error number 44
 List of diagnostic numbers 44
 Structure 42
 Diagnostic message number..... 44
 Diagnostic messages of the drive..... 41
 Display of diagnostic message number..... 43
 Documentation
 Cables 25
 Drive systems 24
 Firmware 25
 Motors 24
 Overview 24
 Reference documentations 24
 System components 24
 Drive control commands..... 71
 Drive system..... 29

E

E0000 E-0000 Processor exception error..... 129
 E2010 Position control with encoder 2 not possible..... 310
 E2011 PLC - Warning no. 1..... 310
 E2012 PLC - Warning no. 2..... 311
 E2013 PLC - Warning no. 3..... 311
 E2014 PLC - Warning no. 4..... 311
 E2015 PLC - Warning no. 5..... 312

Index

E

E2016 PLC - Warning no. 6.....	312
E2017 PLC - Warning no. 7.....	312
E2021 Motor temperature outside of measuring range.....	313
E2026 Undervoltage in power section.....	314
E2040 Device overtemperature 2 prewarning. .	315
E2047 Interpolation velocity = 0.....	315
E2048 Interpolation acceleration = 0.....	316
E2049 Positioning velocity >= limit value.....	317
E2050 Device overtemp. prewarning.....	318
E2051 Motor overtemp. prewarning.....	319
E2053 Target position out of travel range.....	319
E2054 Not homed.....	321
E2055 Feedrate override S-0-0108 = 0.....	321
E2056 Torque limit = 0.....	322
E2058 Selected positioning block has not been programmed.....	323
E2059 Velocity command value limit active.....	324
E2061 Device overload prewarning.....	324
E2063 Velocity command value > limit value....	325
E2064 Target position out of num. range.....	326
E2069 Holding brake torque too low.....	326
E2070 Acceleration limit active.....	327
E2074 Encoder 1: Encoder signals disturbed...	328
E2075 Encoder 2: Encoder signals disturbed...	328
E2076 Measuring encoder: Encoder signals disturbed.....	329
E2077 Absolute encoder monitoring, motor encoder (encoder alarm).....	330
E2078 Absolute encoder monitoring, opt. encoder (encoder alarm).....	331
E2079 Absolute enc. monitoring, measuring encoder (encoder alarm).....	331
E2086 Prewarning supply module overload.....	332
E2092 Internal synchronization defective.....	332
E2100 Positioning velocity of master axis generator too high.....	333
E2101 Acceleration of master axis generator is zero.....	334
E2140 CCD error at node.....	334
E2270 Analog input 1 or 2, wire break.....	334
E2802 HW control of braking resistor.....	335
E2810 Drive system not ready for operation....	336
E2814 Undervoltage in mains.....	336
E2816 Undervoltage in power section.....	337
E2818 Phase failure.....	337
E2819 Mains failure.....	338
E2820 Braking resistor overload prewarning....	338
E2829 Not ready for power on.....	339
E3100 Error when checking input signals.....	302
E3101 Error when checking acknowledgment signal.....	303
E3102 Actual position values validation error...	304
E3103 Dynamization failed.....	304
E3104 Safety parameters validation error.....	305
E3105 Validation error of safe operation mode	305

E

E3106 System error safety technology.....	306
E3107 Safe reference missing.....	307
E3108 Safely-monitored deceleration exceeded.....	307
E3110 Time interval of forced dynamization exceeded.....	308
E3115 Prewarning, end of brake check time interval.....	309
E3116 Nominal load torque of holding system reached.....	309
E4001 Double MST failure shutdown.....	294
E4002 Double MDT failure shutdown.....	295
E4005 No command value input via master communication.....	296
E4006 Communication module overload.....	297
E4007 SERCOS III: Consumer connection failed.....	297
E4008 Invalid addressing command value data container A.....	297
E4009 Invalid addressing actual value data container A.....	298
E4010 Slave not scanned or address 0.....	298
E4011 Communication watchdog: Overload of cyclic communication.....	299
E4012 Maximum number of CCD slaves exceeded.....	299
E4013 Incorrect CCD addressing.....	299
E4014 Incorrect phase switch of CCD slaves...	300
E4016 CCD: Topology error.....	301
E4017 CCD: Unknown I/O configuration.....	301
E8025 Overvoltage in power section.....	279
E8026 Undervoltage in power section.....	280
E8027 Safe torque off while drive enabled.....	281
E8028 Overcurrent in power section.....	281
E8029 Positive position limit exceeded.....	282
E8030 Negative position limit exceeded.....	283
E8034 Emergency-Stop activated.....	284
E8040 Torque/force actual value limit active...	284
E8041 Current limit active.....	285
E8042 Both travel range limit switches activated.....	285
E8043 Positive travel range limit switch activated.....	286
E8044 Negative travel range limit switch activated.....	287
E8055 Motor overload, current limit active.....	287
E8057 Device overload, current limit active.....	288
E8058 Drive system not ready for operation....	289
E8260 Torque/force command value limit active.....	289
E8802 PLL is not synchronized.....	290
E8814 Undervoltage in mains.....	291
E8815 Overvoltage in mains.....	292
E8818 Phase failure.....	292
E8819 Mains failure.....	293
E Adress	84

E

ECL Upd.....	83
E-code channel 1 (P3219 [0]).....	535, 559
E-code channel 2 (P3219 [1]).....	535, 559
E ET SW	85
E FIP CS	83
E FIP nf	83
E HW nok	85
Electric drive system.....	29
E Length	84
E MMC cl	84
E MMC cp	85
E MMC op	84
End C29	81
EPF Upd.....	83
E Pge Sz	83
EPL Upd.....	83
Error classes.....	72
Error in motion profile.....	218
Error memory.....	73
Error messages of serial communication.....	276
Error number.....	44
Error reactions	
Drive error reactions	73
Errors.....	72
Drive error reactions	73
E SW-VER	86
Extended diagnosis.....	535
Extended diagnosis as of MPx07.....	559

F

F2002 Assignment of encoder for synchroni- zation is not allowed.....	216
F2003 Motion step skipped.....	217
F2004 Error in MotionProfile.....	218
F2005 Cam table invalid.....	219
F2006 MMC was removed.....	220
F2007 Switching to non-initialized operation mode.....	220
F2008 RL The motor type has changed.....	221
F2009 PL Load parameter default values.....	222
F2010 Error when initializing digital I/O (-> S-0-0423).....	223
F2011 PLC - Error no. 1.....	224
F2012 PLC - Error no. 2.....	225
F2013 PLC - Error no. 3.....	225
F2014 PLC - Error no. 4.....	225
F2015 PLC - Error no. 5.....	226
F2016 PLC - Error no. 6.....	226
F2017 PLC - Error no. 7.....	227
F2018 Device overtemperature shutdown.....	227
F2019 Motor overtemperature shutdown.....	228
F2021 Motor temperature monitor defective....	229
F2022 Device temperature monitor defective...	230
F2025 Drive not ready for control.....	230
F2026 Undervoltage in power section.....	231
F2027 Excessive oscillation in DC bus.....	231

F

F2028 Excessive deviation.....	232
F2031 Encoder 1 error: Signal amplitude in- correct.....	232
F2032 Validation error during commutation fine adjustment.....	233
F2033 External power supply X10 error.....	234
F2036 Excessive position feedback difference.	234
F2037 Excessive position command difference	235
F2039 Maximum acceleration exceeded.....	236
F2040 Device overtemperature 2 shutdown....	236
F2042 Encoder 2: Encoder signals incorrect...	237
F2043 Measuring encoder: Encoder signals incorrect.....	238
F2044 External power supply X15 error.....	239
F2048 Low battery voltage.....	239
F2050 Overflow of target position preset memory.....	240
F2051 No sequential block in target position preset memory.....	241
F2053 Incr. encoder emulator: Pulse fre- quency too high.....	241
F2054 Incr. encoder emulator: Hardware error.	242
F2055 External power supply dig. I/O error....	243
F2057 Target position out of travel range.....	243
F2058 Internal overflow by positioning input....	244
F2059 Incorrect command value direction when positioning.....	245
F2063 Internal overflow master axis generator.	246
F2064 Incorrect cmd value direction master axis generator.....	246
F2067 Synchronization to master communi- cation incorrect.....	247
F2068 Brake error.....	247
F2069 Error when releasing the motor hold- ing brake.....	248
F2074 Actual pos. value 1 outside absolute encoder window.....	249
F2075 Actual pos. value 2 outside absolute encoder window.....	249
F2076 Actual pos. value 3 outside absolute encoder window.....	250
F2077 Current measurement trim wrong.....	251
F2086 Error supply module.....	252
F2087 Module group communication error.....	252
F2100 Incorrect access to command value memory.....	253
F2101 It was impossible to address MMC.....	253
F2102 It was impossible to address I2C memory.....	254
F2103 It was impossible to address EnDat memory.....	254
F2104 Commutation offset invalid.....	255
F2105 It was impossible to address Hiper- face memory.....	255
F2110 Error in non-cyclical data communic. of power section.....	256

Index

F

F2120 MMC: Defective or missing, replace.....	256
F2121 MMC: Incorrect data or file, create correctly.....	257
F2122 MMC: Incorrect IBF file, correct it.....	257
F2123 Retain data backup impossible.....	258
F2124 MMC: Saving too slowly, replace.....	259
F2130 Error comfort control panel.....	259
F2140 CCD slave error.....	260
F2150 MLD motion function block error.....	260
F2174 Loss of motor encoder reference.....	261
F2175 Loss of optional encoder reference.....	261
F2176 Loss of measuring encoder reference... ..	262
F2177 Modulo limitation error of motor encoder.....	263
F2178 Modulo limitation error of optional encoder.....	263
F2179 Modulo limitation error of measuring encoder.....	264
F2190 Incorrect Ethernet configuration.....	264
F2260 Command current limit shutoff.....	265
F2270 Analog input 1 or 2, wire break.....	266
F2802 PLL is not synchronized.....	267
F2814 Undervoltage in mains.....	267
F2815 Overvoltage in mains.....	267
F2816 Softstart fault power supply unit.....	268
F2817 Overvoltage in power section.....	268
F2818 Phase failure.....	269
F2819 Mains failure.....	270
F2820 Braking resistor overload.....	270
F2821 Error in control of braking resistor.....	271
F2825 Switch-on threshold braking resistor too low.....	272
F2833 Ground fault in motor line.....	272
F2834 Contactor control error.....	273
F2835 Mains contactor wiring error.....	273
F2836 DC bus balancing monitor error.....	274
F2837 Contactor monitoring error.....	274
F2840 Error supply shutdown.....	274
F2860 Overcurrent in mains-side power section.....	275
F2890 Invalid device code.....	276
F2891 Incorrect interrupt timing.....	276
F2892 Hardware variant not supported.....	276
F3111 Refer. missing when selecting safety related end pos.....	190
F3112 Safe reference missing.....	191
F3115 Brake check time interval exceeded.....	193
F3116 Nominal load torque of holding system exceeded.....	194
F3117 Actual position values validation error... ..	195
F3122 SBS: System error.....	196
F3123 SBS: Brake check missing.....	196
F3130 Error when checking input signals.....	197
F3131 Error when checking acknowledgment signal.....	198

F

F3132 Error when checking diagnostic output signal.....	199
F3133 Error when checking interrupting circuits.....	200
F3134 Dynamization time interval incorrect.....	201
F3135 Dynamization pulse width incorrect.....	203
F3140 Safety parameters validation error.....	205
F3141 Selection validation error.....	206
F3142 Activation time of enabling control exceeded.....	206
F3143 Safety command for clearing errors incorrect.....	208
F3144 Incorrect safety configuration.....	209
F3145 Error when unlocking the safety door... ..	210
F3146 System error channel 2.....	211
F3147 System error channel 1.....	212
F3150 Safety command for system start incorrect.....	213
F3151 Safety command for system halt incorrect.....	214
F3152 Incorrect backup of safety technology data.....	214
F3160 Communication error of safe communication.....	215
F4001 Sync telegram failure.....	180
F4002 RTD telegram failure.....	181
F4003 Invalid communication phase shutdown	183
F4004 Error during phase progression.....	183
F4005 Error during phase regression.....	183
F4006 Phase switching without ready signal... ..	184
F4009 Bus failure.....	184
F4011 Communication watchdog: Overload of cyclic communication.....	186
F4012 Incorrect I/O length.....	187
F4016 PLC double real-time channel failure....	187
F4017 S-III: Incorrect sequence during phase switch.....	188
F4034 Emergency-Stop activated.....	188
F4140 CCD communication error.....	189
F6006 Incorrect initialization of effective master axis position.....	171
F6010 PLC runtime error.....	172
F6024 Maximum braking time exceeded.....	173
F6028 Position limit value exceeded (overflow)	174
F6029 Positive position limit exceeded.....	175
F6030 Negative position limit exceeded.....	176
F6034 Emergency-Stop activated.....	176
F6042 Both travel range limit switches activated.....	177
F6043 Positive travel range limit switch activated.....	178
F6044 Negative travel range limit switch activated.....	179
F6140 CCD slave error (emergency halt).....	179
F7010 Safely-limited increment exceeded.....	161

F

F7011 Safely-monitored position, exceeded in pos. direction..... 162
 F7012 Safely-monitored position, exceeded in neg. direction..... 162
 F7013 Safely-limited speed exceeded..... 163
 F7014 Timeout safely-monitored transient oscillation..... 163
 F7020 Safe maximum speed exceeded..... 164
 F7021 Safely-limited position exceeded..... 165
 F7030 Position window Safe stop 2 exceeded. 165
 F7031 Incorrect direction of motion..... 166
 F7040 Validation error parameterized - effective threshold..... 166
 F7041 Actual position value validation error.... 167
 F7042 Validation error of safe operation mode. 168
 F7043 Error of output stage interlock..... 168
 F7050 Time for stopping process exceeded..... 169
 F7051 Safely-monitored deceleration exceeded..... 169
 F8000 Fatal hardware error..... 132
 F8010 Autom. commutation: Max. motion range when moving back..... 133
 F8011 Commutation offset could not be determined..... 134
 F8012 Autom. commutation: Max. motion range..... 135
 F8013 Automatic commutation: Current too low..... 135
 F8014 Automatic commutation: Overcurrent.... 136
 F8015 Automatic commutation: Timeout..... 137
 F8016 Automatic commutation: Iteration without result..... 137
 F8017 Automatic commutation: Incorrect commutation adjustment..... 138
 F8018 Device overtemperature shutdown..... 139
 F8022 Enc. 1: Enc. signals incorr. (can be cleared in ph. 2)..... 140
 F8023 Error mechanical link of encoder or motor connection..... 141
 F8025 Overvoltage in power section..... 141
 F8027 Safe torque off while drive enabled..... 142
 F8028 Overcurrent in power section..... 143
 F8030 Safe stop 1 while drive enabled..... 143
 F8042 Encoder 2 error: Signal amplitude incorrect..... 144
 F8057 Device overload shutdown..... 145
 F8060 Overcurrent in power section..... 145
 F8064 Interruption of motor phase..... 146
 F8067 Synchronization PWM-Timer wrong..... 147
 F8069 +/-15Volt DC error..... 147
 F8070 +24Volt DC error..... 148
 F8076 Error in error angle loop..... 148
 F8078 Speed loop error..... 149
 F8079 Velocity limit value exceeded..... 150
 F8091 Power section defective..... 150

F

F8100 Error when initializing the parameter handling..... 151
 F8102 Error when initializing power section.... 152
 F8118 Invalid power section/firmware combination..... 152
 F8120 Invalid control section/firmware combination..... 153
 F8122 Control section defective..... 153
 F8129 Incorrect optional module firmware..... 153
 F8130 Firmware of option 2 of safety technology defective..... 154
 F8133 Error when checking interrupting circuits..... 154
 F8134 SBS: Fatal error..... 155
 F8135 SMD: Velocity exceeded..... 156
 F8140 Fatal CCD error..... 156
 F8201 Safety technology basic initialization incorrect..... 156
 F8203 Safety technology configuration parameter invalid..... 157
 F8813 Connection error mains choke..... 158
 F8830 Power section error..... 159
 F8838 Overcurrent external braking resistor... 159
 F9001 Error internal function call..... 130
 F9002 Error internal RTOS function call..... 131
 F9003 Watchdog..... 131
 F9004 Hardware trap..... 131
 Firmware
 Documentation 25
 Firmware update ?..... 82
 FL: CKS 590
 FL: DL 589
 FL:E ADR 590
 FL:E FW 590
 FL:E LD 591
 FL:ERASE 590
 FL:E SEC 590
 FL:E SEQ 591
 FL:F2100 591
 FL:F2101 592
 FL:F8120 593
 FL:F8122 592
 FL:F8129 592
 FL:F8130 592
 FL:F9002 591
 FL:F ACC 592
 FL:F CKS 591
 FL: PROG 590

G

Generation of diagnostic messages, drive-internal..... 41

Index

H

H14	
LED (KSM/KMS)	585
H52.1...H54	
LEDs (KCU)	587

I

IBF not correct!.....	82
Inappropriate use.....	28
Consequences, exclusion of liability	27

K

KCU	
LEDs	587
Kinds of diagnostic messages.....	41
KMS	
LED H14	585
KSM	
LED H14	585

L

Language selection.....	44
LED	
H14 (KSM/KMS)	585
H52.1...H54 (KCU)	587
List of diagnostic numbers.....	44
LOADER.....	589
Loading parameter values, general.....	70
Load New Safety ?.....	80
Load Par from MMC.....	81

M

Means of representation	
Conventions of notation	23
Notations	23
Notes	23
MMC not correct!.....	81
Monitor commands.....	71
Motion profile, encoder 1, real master axis.....	113
Motion profile, encoder 1, virtual master axis... ..	112
Motion profile, encoder 2, real master axis.....	113
Motion profile, encoder 2, virtual master axis... ..	112
Motion profile lagless, encoder 1, real master axis.....	115
Motion profile lagless, encoder 1, virtual master axis.....	114
Motion profile lagless, encoder 2, real master axis.....	115
Motion profile lagless, encoder 2, virtual master axis.....	114
Motor	
Documentation	24

N

new MMC activate.....	81
-----------------------	----

N

No IDN on MMC !.....	80
Non-volatile data memories.....	69

O

OM.....	76
Operating states.....	75
Operation modes	
Basic principles	71

P

P0.....	76
P-0-3219	
Extended diagnosis	535
Extended diagnosis as of MPx07	559
P1.....	76
P2.....	76
P3.....	76
Parameter handling, general.....	69
Parameters	
Definitions of terms	69
Password.....	70
PELV.....	34
PL.....	76
PLC ?	79
PLC error.....	224, 225, 226, 227
PM.....	76
Project planning manuals.....	24
Protective extra-low voltage.....	34

R

Reference documentations.....	24
RL.....	76
Run PLC	80

S

S3L Upd.....	83
Safety instructions for electric drives and controls.....	29
Saving parameter values, general.....	69
SBB.....	76
SBB1.....	77
SBB2.....	77
SBB3.....	77
SBB4.....	77
SBH.....	77
SERCOS service channel error codes.....	276
SH.....	77
SMM1.....	77
SMM2.....	77
SMM3.....	77
SMM4.....	77
SS1.....	77
SS1 ES.....	77
SS2.....	77

S

State-of-the-art.....	27
Status classes.....	44
Status displays.....	47
STO.....	77
Stop PLC	80
Structure of diagnostic message.....	42
Support	
See service hotline	603
Synchronous motor.....	347

T

Types of commands.....	71
Types of passwords, overview.....	70

U

Update Error !.....	82
Use	
Appropriate use	27
Inappropriate use	28

V

VM bb.....	75
------------	----

V

VM Bb.....	75
VM charg.....	76
VM Lb.....	78
VM LB.....	78
VM P0.....	76
VM P1.....	76
VM P2.....	76
VM P3.....	76
VM ZKS.....	78

W

Warning classes.....	72
Warnings.....	72

X

XXX Upd	82
---------------	----

Notes

Bosch Rexroth AG
Electric Drives and Controls
P.O. Box 13 57
97803 Lohr, Germany
Bgm.-Dr.-Nebel-Str. 2
97816 Lohr, Germany
Tel. +49 9352 18 0
Fax +49 9352 18 8400
www.boschrexroth.com/electrics



R911297319

DOK-INDRV*-GEN-**VRS**-WA08-EN-P